

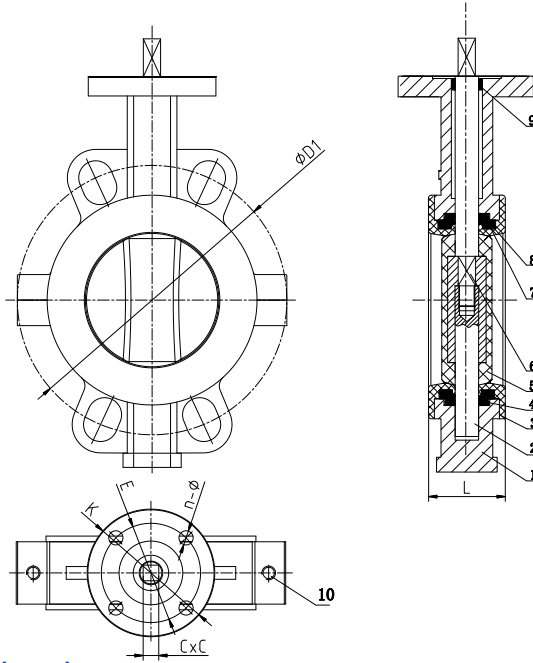

PTFE Coated Butterfly Valve(Wafer Type)



- **Type:**
Wafer
- **Face to Face:**
API609,BS5155,DIN3202,ISO5752
- **Flange:**
DIN,BS,UNI,ISO, ANSI, AS,JIS
- **Mounting Flange:**
ISO5211
- **Working Pressure:**
PN16(200PSI)
- **Appliaction:**
HVAC,Water Supply&Sewage,
Food&Beverage,Chemical/
petrochemical/processing,
Power and Utilities,Paper
and Pulp,Ship Building.

DIMENSIONS:(mm)

SIZE	D1 150LB	D1 PN10	D1 PN16	D1 10K	L	CXC	ISO5211	K	E	n-Ø
DN50	120.7	125	125	120	43	9X9	F07	90	70	50
DN65	139.7	145	145	140	46	9X9	F07	90	70	65
DN80	152.4	160	160	150	46	9X9	F07	90	70	80
DN100	190.5	180	180	175	52	11X11	F07	90	70	100
DN125	215.9	210	210	210	56	14X14	F07	90	70	125
DN150	241.3	240	240	240	56	14X14	F07	90	70	150
DN200	298.5	295	295	290	60	17X17	F10	125	102	200
DN250	362	350	355	355	68	22X22	F10	125	102	250
DN300	431.8	400	410	400	78	22X22	F10	125	102	300

STANDARD MATERIALS OF MAIN PARTS

10	BOLT	SS304	2/4
9	BUSHING	PTFE	1
8	PRESSING SLEEVE	STAINLESS STEEL	2
7	SEAT ENERQIZER	SILICONE	2
6	UP SHAFT	SS410/SS304/SS316	1
5	DISC	CF8M+PTFE	1
4	BUTTERFLY SPRING	SPRING STEEL	8
3	LINER(SEAT)	PTFE	1
2	DOWN SHAFT	SS410	1
1	BODY	CI/DI	2
NO.	NAME	MATERIAL	QTY
TEST PRESSURE	CWP:10 BAR	SHELL	SEAL
	HYDROSTATIC	15BAR	11BAR
	AIR		
STANDARD	DESIGN	AP1609	
	INSPECTION & TEST	API598	
	END STANDARD	EN1092-2 PN6/10/16/AS"D""E"/JIS B2220 10K/ASME B16.5 150LB	
	FACE TO FACE	API609	