

YOU WILL NEED

- PHILLIPS HEAD SCREWDRIVER
- FLAT HEAD SCREWDRIVER
- SOFT HEAD Mallet

PARTS LIST

- 1 SIDE PANEL LEFT
- 2 SIDE PANEL RIGHT
- 3 TOP PANEL
- 4 BOTTOM PANEL
- 5 BACK PANEL
- 6 DRAWER FRONT PANEL (X2)
- 7 DRAWER BACK PANEL (X2)
- 8 DRAWER BASE PANEL (X2)
- 9 DRAWER SIDE PANEL LEFT (X2)
- 10 DRAWER SIDE PANEL RIGHT (X2)
- 11 SUPPORT PANEL

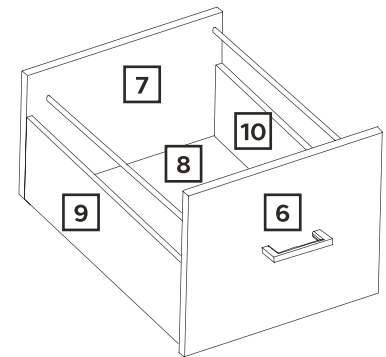
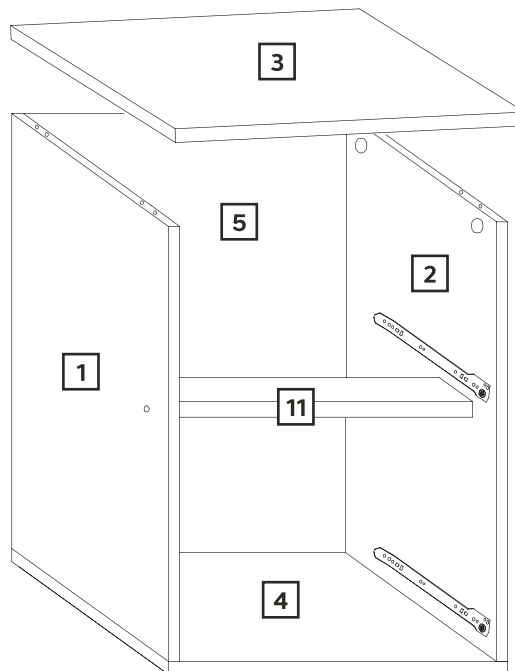

DRAWERS (x2)

HARDWARE INCLUDED

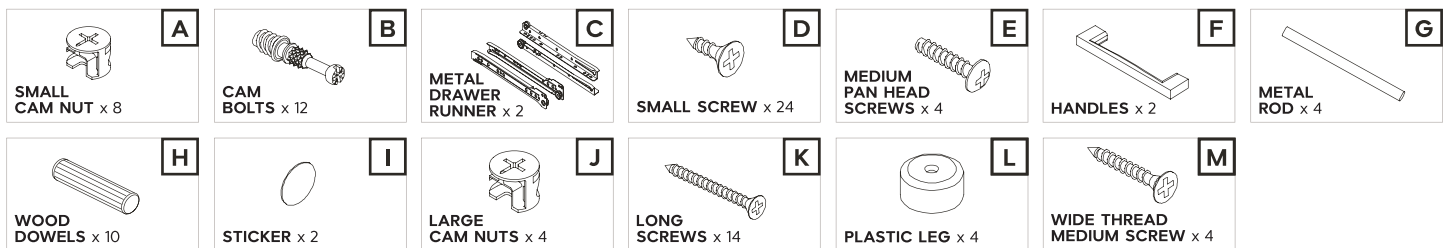

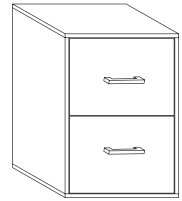

STEP 1

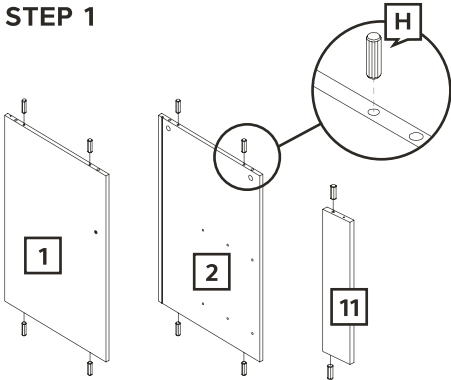

Insert wood dowels (H) into pre-drilled holes in side panel left (1), side panel right (2) and support panel (11) as shown above.

STEP 2

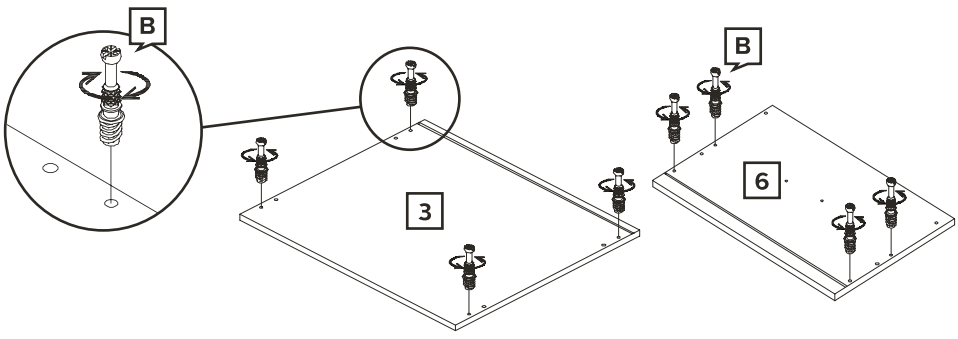

Attach cam bolts (B) to top panel (3) and 2 x drawer front panel (6) by screwing in a clockwise direction with a phillips head screwdriver.

X2

STEP 3

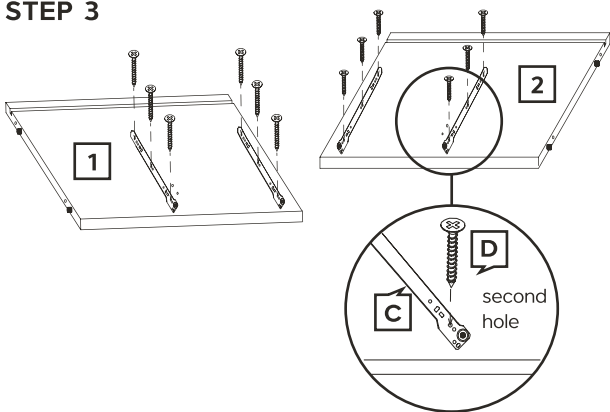

Attach metal drawer runners (C) to side panel left (1) and side panel right (2) with small screws (D), tightening with a phillips head screwdriver.

STEP 4

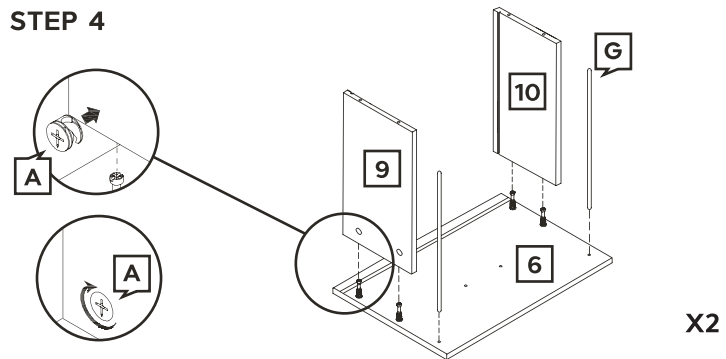

Align cam bolts in drawer front panel (6) with pre-drilled holes in drawer side panel left (9) and drawer side panel right (10). Insert small cam nuts (A), with arrows pointing towards the drawer front panel (6), then tighten using a phillips head screwdriver. Insert 2 x metal rods (G) into pre-drilled holes in drawer front panel (6). Repeat to assemble the remaining drawers.

X2

STEP 5

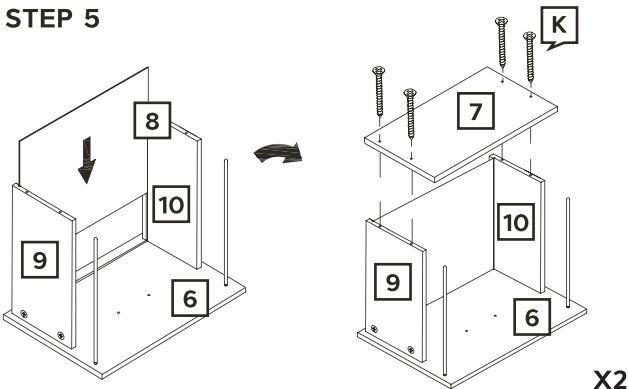

Slide drawer base panel (8) into the grooves in the drawer side panels and drawer front panel (6). Attach drawer back panel (7) to drawer side panel left (9) and drawer side panel right (10) using long screws (K). Repeat to assemble the remaining drawer assemblies

X2

STEP 6

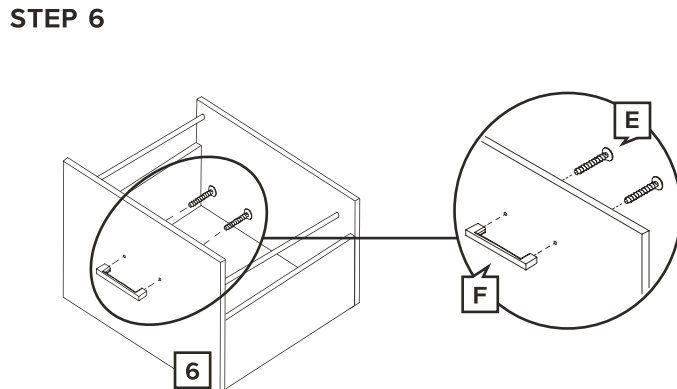

Attach handles (F) to drawer front panel (6) using medium pan head screws (E). Repeat to assemble the remaining drawer assemblies.

X2

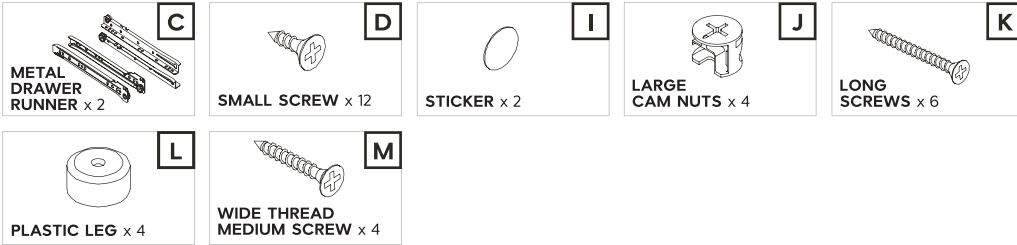
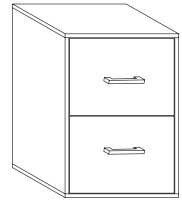

STEP 7

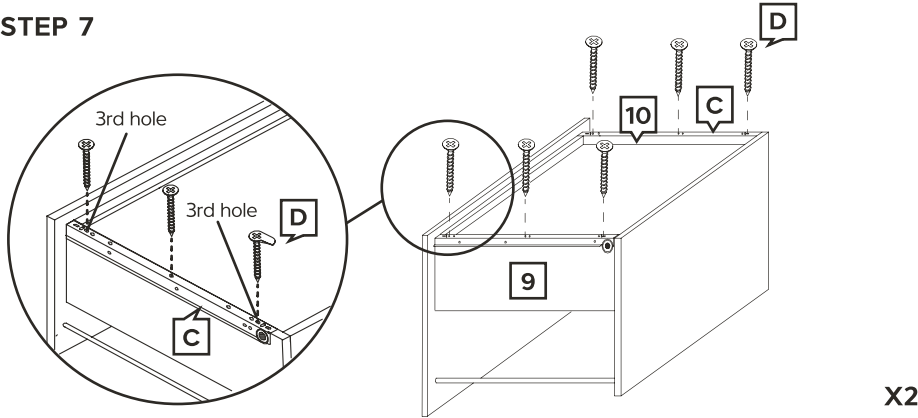

Attach metal drawer runners (C) to underside of drawer side panel left (9) and drawer side panel right (10) with small screws (D), tightening with a phillips head screwdriver. Repeat to assemble the remaining drawer assemblies.

STEP 8

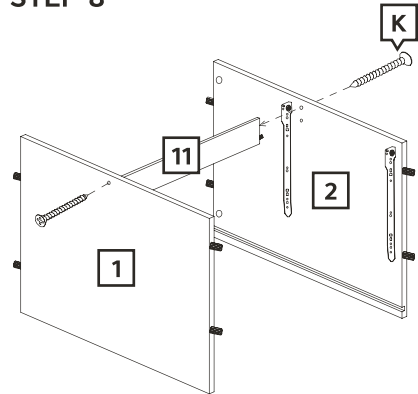

Attach support panel (11) to side panel left (1) and side panel right (2) using long screws (K).

STEP 9

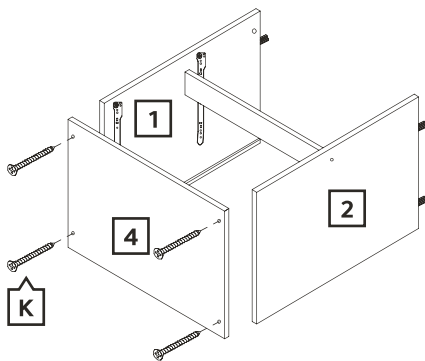

Attach bottom panel (4) to side panel left (1) and side panel right (2) using long screws (K).

STEP 10

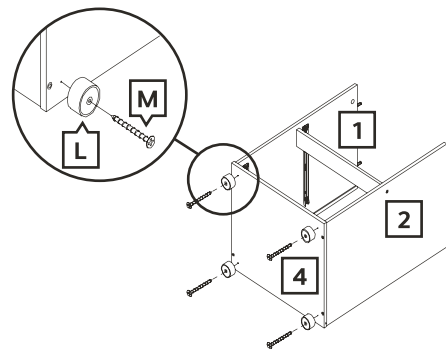

Attache plastic studs (L) to bottom panel (4) using wide thread medium crews (M)

STEP 11

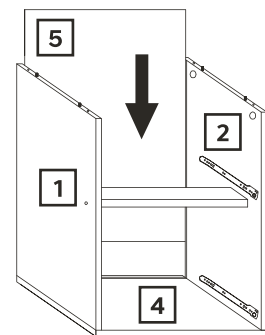

Slide back panel (5) into grooves in side panel left (1), side panel right (2) and bottom panel (4).

STEP 12

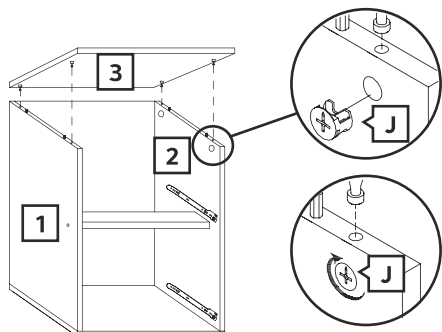

Align cam bolts in top panel (3) with pre-drilled holes in side panel left (1) and side panel right (2). Insert large cam nuts (J), with arrows pointing towards the top panel (3), then tighten using a phillips head screwdriver.

STEP 13

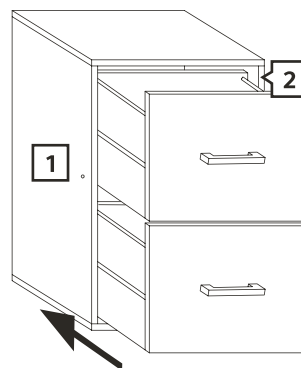

Slide two drawer assemblies onto the metal drawer slides fixed to side panel left (1) and Side panel right (2).

STEP 14

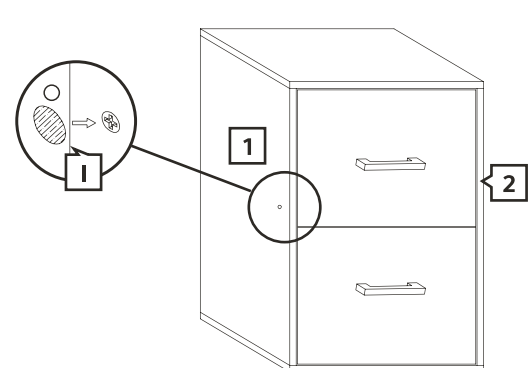

Place stickers (I) over the screw holes in side panels.

Subject to proof of purchase, DIY Resolutions Pty Ltd (“DIY”) provides the following limited warranties to the original purchaser of MacLaren products purchased and used in Australia only on the following terms and conditions:

Standard 1 Year Warranty

DIY warrants that it will, at its option, repair or replace any cabinet, drawers, hinge and drawer runner, handle, door, panel, shelving and timber tabletop or laminate tabletop that suffers a failure due to a defect in the materials or manufacturing process within one (1) year from the date of purchase. Under this warranty, a cabinet is defined as the main framework remaining after all coverings, doors, panels, frames for these panels, benchtops and (non-structural) shelves are removed.

For the warranty to apply

This warranty applies only to the original purchaser of MacLaren products used for normal, personal, domestic and household purposes only.

The original purchaser may obtain the benefit of this warranty on the following conditions:

1. The MacLaren product was purchased from an authorised MacLaren retailer and was paid for in full;
2. The original purchaser is able to provide an acceptable form of proof of purchase;
3. The MacLaren product was installed and is used in accordance with all supplied product information and instructions; and
4. DIY is notified within thirty (30) days of the alleged problem occurring.

DIY aims to rectify genuine warranty claims as a matter of priority. This is generally achieved by inspecting the product and determining the basis for the claim and by introducing immediate corrective action measures to prevent re-occurring problems. It is therefore essential that all warranty claims are promptly submitted to DIY within the thirty (30) day period of the alleged problem occurring as stated above.

This warranty represents the only warranty given by DIY and no other person or organisation is authorised to offer any alternative.

Exclusions and limitations

This warranty does NOT cover:

- Products without proof of purchase
- Products not purchased from an authorised MacLaren retailer
- Products which have not been paid for in full
- Products which are resold or resupplied or constitute second hand goods
- Normal wear and tear
- Usage other than normal personal, domestic or household use,
- Installation that is not in accordance with supplied installation instructions
- Defects which have been disclosed as a feature or limitation of the products in any literature published by DIY
- Variations in colour and shade
- Delamination
- General colour fading or discolouration or damage due to direct and indirect light (exposure to direct sunlight should be avoided)

- Slight variations or differences in the visual features of the products inherent within the manufacturing process.
- Accident, misuse, abuse, negligence, improper handling or failure to follow supplied care directions
- Exposure to excessive heat, moisture, ultra violet light or physical or chemical abuse (such as oven cleaners, floor and paint strippers and other harsh chemicals)
- Alteration, modification, repair or use of the product which is inconsistent with supplied product instructions
- Damage, problems or failure caused by acts of God, fire, wind, lightning, flood, storm, vandalism, earthquake, war, civil insurrection, pests, vermin, insects, spiders or interference by foreign objects or matter affecting the product such as dirt, debris, soot or moisture
- Damage, problems or failure caused by extreme weather conditions, including, but not limited to, hail, salt, or other harsh substances
- Products which have been installed in a portable or mobile building, structure or application including, but not limited to, a caravan or boat, unless you have prior written consent of DIY
- Products which are re-installed at a location other than the original installation site
- Inadequate support in the structure to which the product is installed
- Repairs to products without the authorisation of DIY in writing

If your MacLaren product has been discontinued, DIY may offer at its option a replacement with a similar MacLaren product. DIY does not warrant that replacement will fit any existing fixtures or chattels.

DIY does not warrant the removal, installation, deinstallation, reinstallation or set up costs or any other associated costs with a claim.

DIY does not warrant any consequential, incidental, direct or indirect loss, expense or damage suffered by you or any third party arising from or in relation to the use, installation, performance or failure of any MacLaren product.

How to claim

To make a claim under this warranty, you must provide a copy of your original proof of purchase and proof of installation to enable us to determine whether your MacLaren product falls within the warranty and the relevant warranty periods. This will also help us determine whether the claim made is genuine and is not based on any breach of warranty or any violations of the law, such as those involving lost, stolen, counterfeit or second-hand goods.

The acceptable proof of purchase can be a tax invoice or receipt that clearly itemises the product and shows the date and place of purchase and, if applicable, information pertaining to the installation of your MacLaren product. As a strict condition, where there is no acceptable form of proof of purchase, DIY undertakes no responsibility to repair the product under warranty.

You will need to contact DIY during the applicable warranty period on the contact details provided below. To enable DIY to correctly identify and rectify the problem, please be ready to provide accurate details of your MacLaren product and finish, date of purchase, date of installation, purchase details and a full description of the problem. Our customer service representatives will let you know what other information is required for processing your claim. Importantly, you will need to arrange with DIY inspection of your product as part of our assessment of your claim.

Please bear in mind you will be responsible for all expenses involved in contacting DIY to make your claim under this warranty and DIY will bear the expenses of any applicable inspection and processing of your claim.

By email at

online@austbrush.com.au

By telephone in Australia

1800 666 078

Monday to Friday
From 8:00am to 6:00pm AEST

How DIY will fulfil warranty claims

DIY will honour all valid claims made under this warranty by either repairing or replacing (at DIY's option) your MacLaren product.

You will be charged

You WILL BE CHARGED for work done or any service call(s) if:

- The problem is not covered by this warranty
- There is nothing wrong with the product
- You are unable to provide acceptable proof of purchase and decide to proceed with your claim

We strongly recommend that you read all instructions supplied upon purchase of your MacLaren product before making a warranty claim.

Other rights

The benefits provided to you under this warranty are in addition to any other rights or remedies you may have as a consumer under any other law which applies to our products.

Our goods and services come with guarantees that cannot be excluded under the Australian Consumer Law. For major failures with the service, you are entitled:

- to cancel your service contract with us; and
- to a refund for the unused portion, or to compensation for its reduced value.

You are also entitled to choose a refund or replacement for major failures with goods. If a failure with the goods or service does not amount to a major failure, you are entitled to have the failure rectified in a reasonable time. If this is not done you are entitled to a refund for the goods and to cancel the contract for the service and obtain a refund of any unused portion. You are also entitled to be compensated for any other reasonably foreseeable loss or damage from a failure in the goods or service.

Checklist to be completed and submitted to DIY when making a claim

Your name

Your address

Your telephone number

Your authorised MacLaren retailer

Your authorised MacLaren retailer's address

Product model number (if applicable)

Product serial number (if applicable)

Date of installation

Installed by

Installer's address

Have you provided a copy of your proof of purchase (please circle)? Yes / No

Provide a brief description of your claim, including the problem and when you found out about it

Have you provided any photographs of the product (please circle)? Yes / No

Dated

Signed
