

STEP 1

Check included hardware.

You will need:



Screwdriver







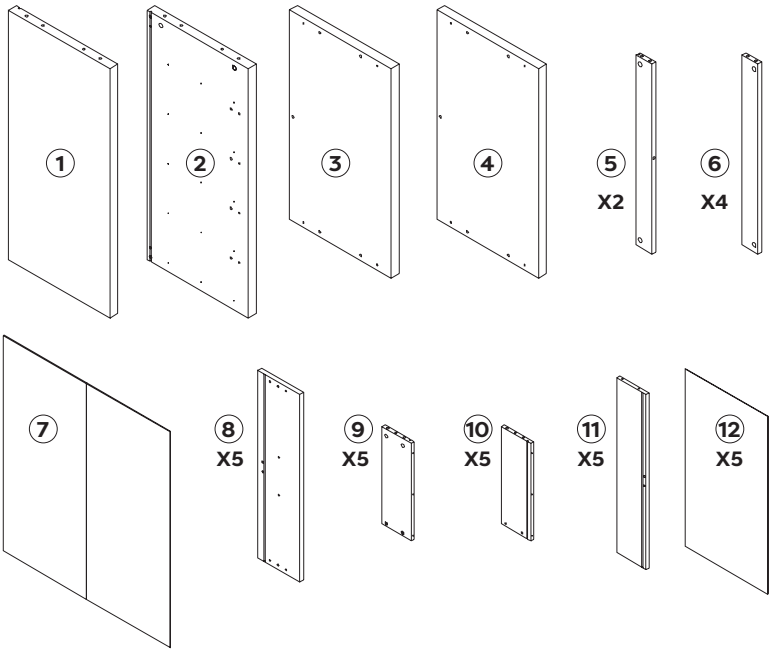





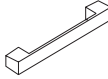







Hammer

Parts list:

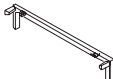
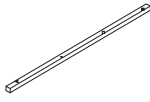

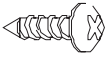
Hardware pack:

<p>A</p>  <p>Wood Dowel M6X25 x 15</p>	<p>B</p>  <p>Wood Dowel M8X25 x 22</p>	<p>C</p>  <p>Screw Truss Head M4X22 x 10</p>	<p>D</p>  <p>Handle x 5</p>	<p>E</p>  <p>Euro Bolt x 41</p>	<p>F</p>  <p>Housing D:15/12.5mm x 16</p>
<p>G</p>  <p>Housing D:12/9.5mm x 25</p>	<p>H</p>  <p>Screw #9x2" x 4</p>	<p>I</p>  <p>Screw #9x1 1/2" x 30</p>	<p>J</p>  <p>Screw M3x20 x 6</p>	<p>K</p>  <p>Corner Block x 6</p>	<p>L</p>  <p>Screw JCBC M6x10 x 4</p>
<p>M</p>  <p>Screw M4x12 x 60</p>	<p>N</p>  <p>Allen Key x 1</p>	<p>O</p>  <p>Screw Pan Head #8x35 x 10</p>	<p>P</p>  <p>Leg 1 x 2</p>	<p>Q</p>  <p>Leg 2 x 2</p>	<p>R</p>  <p>Metal Runner x 5 Sets</p>
<p>S</p>  <p>Screw Pan Head 3.5x12 x 1</p>	<p>T</p>  <p>Webbing x 1</p>	<p>U</p>  <p>Washer x 1</p>			



STEP 2

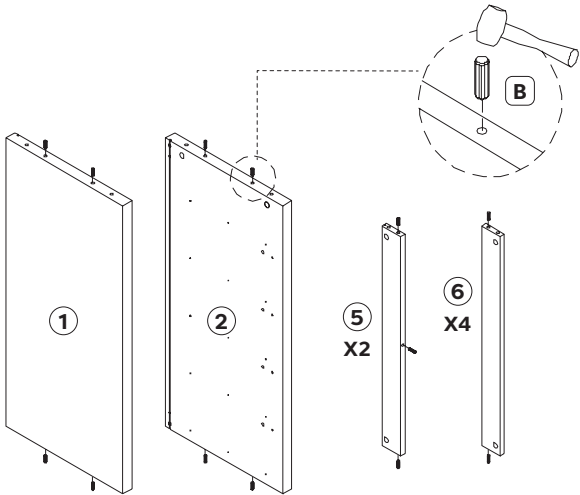

STEP 2B

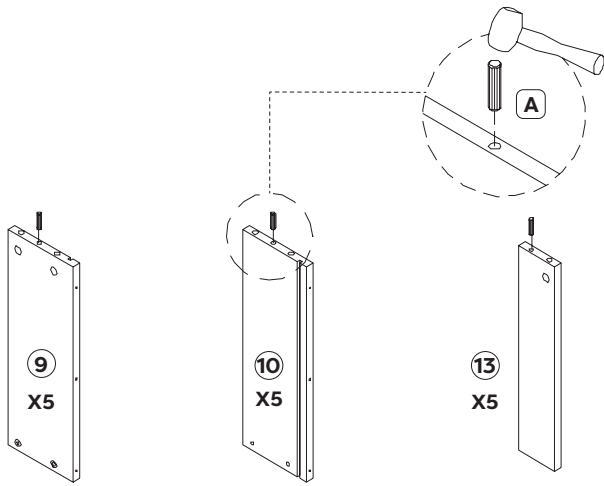

STEP 3

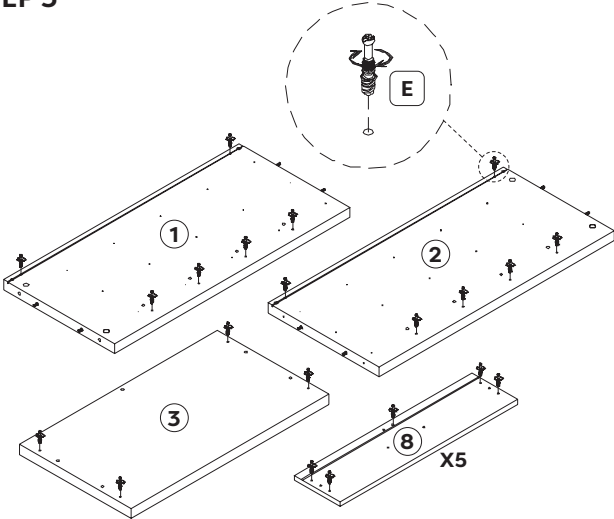

STEP 4

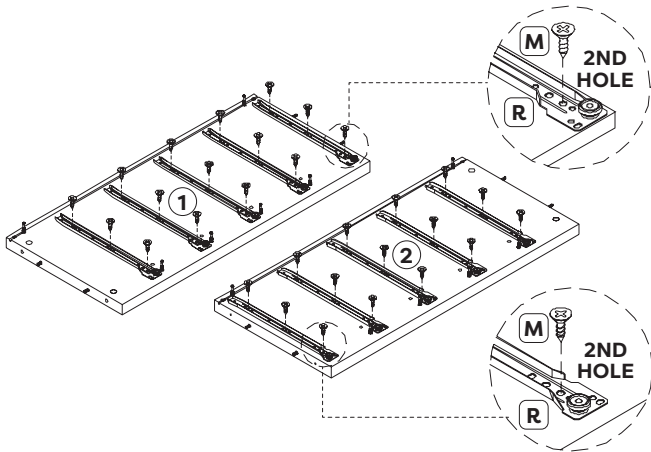

STEP 5 x 5

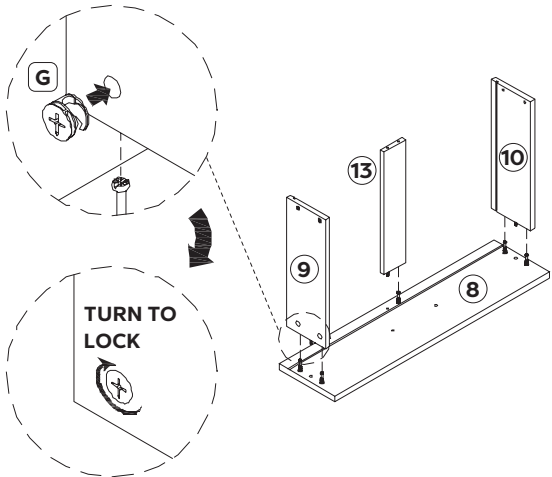

STEP 6 x 5

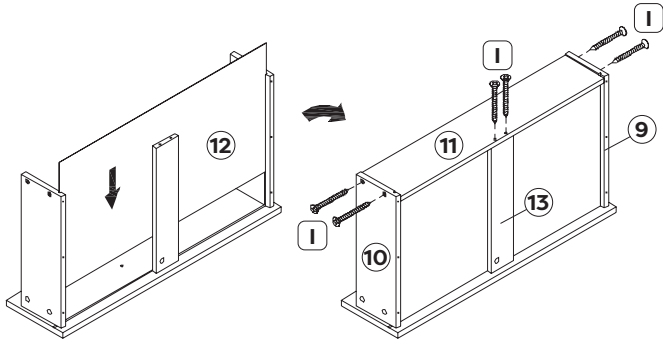



STEP 7 x 5

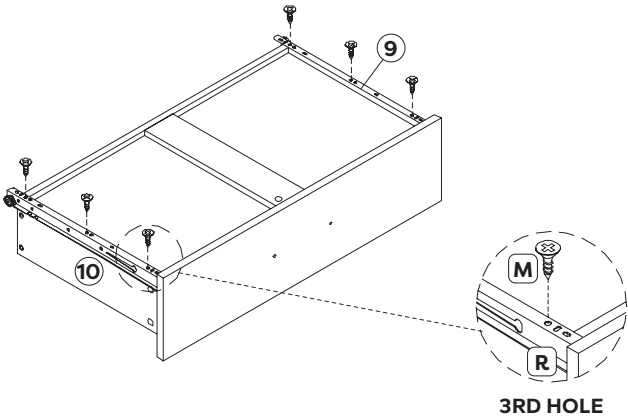

STEP 8 x 5

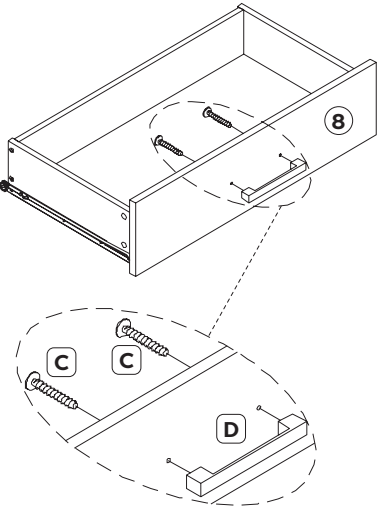

STEP 9

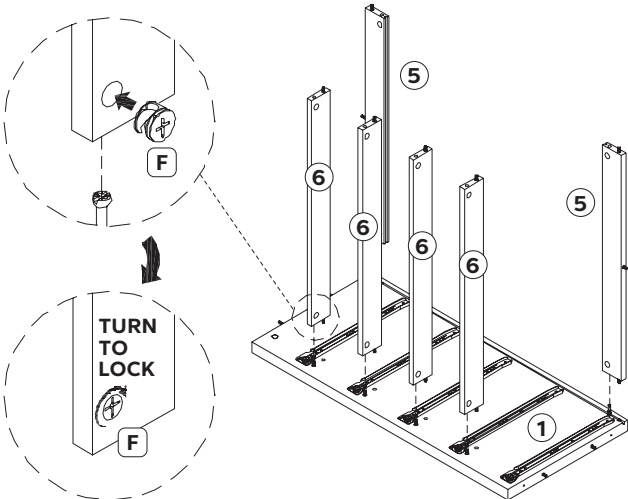

STEP 10

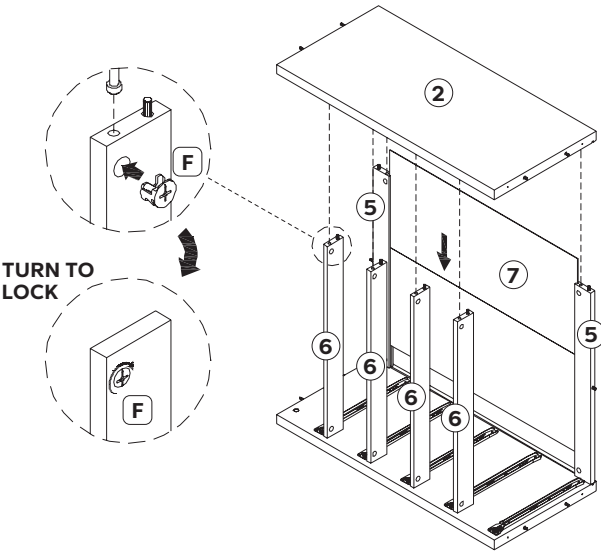

STEP 11

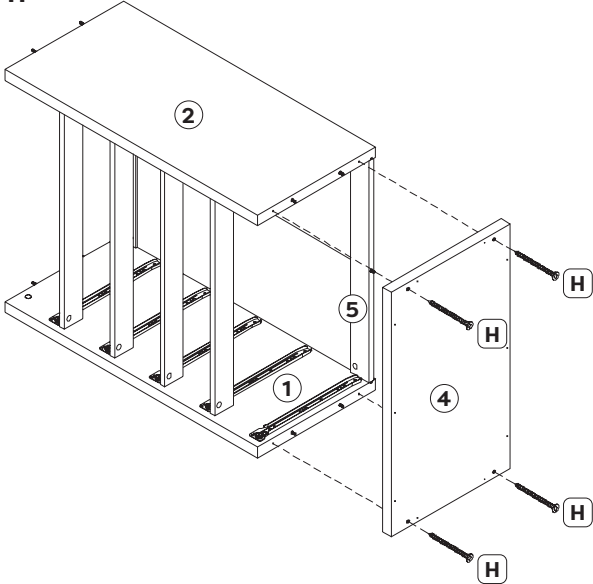

STEP 12

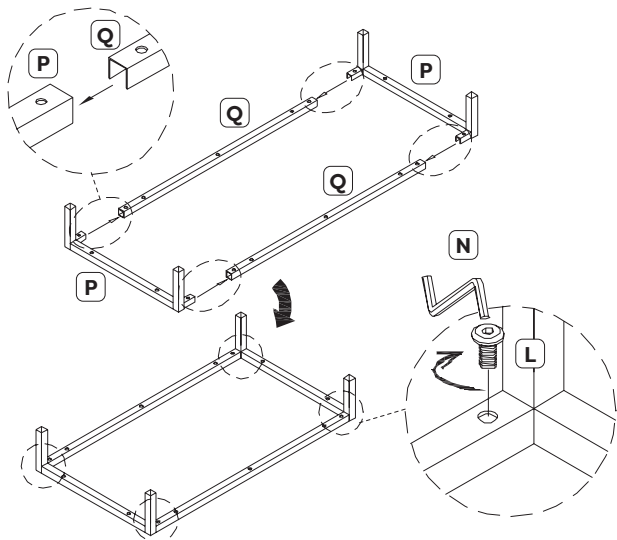

AUBREY 5 DRAWER DRESSER

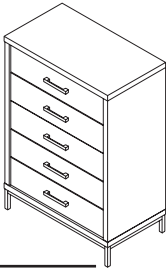

STEP 13

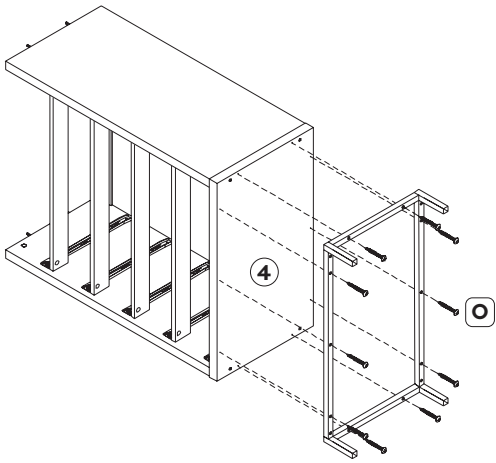

STEP 14

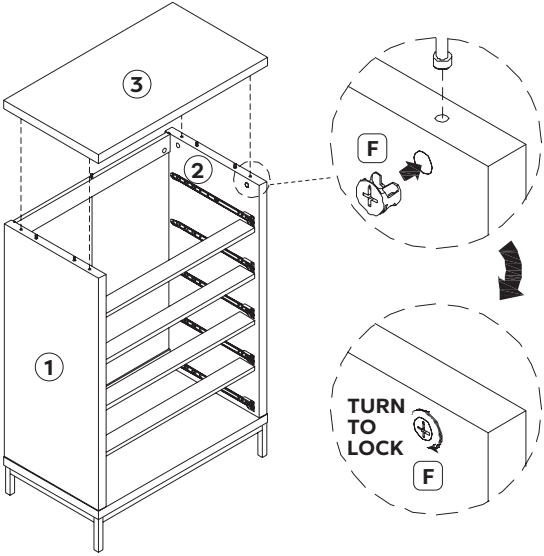

STEP 15

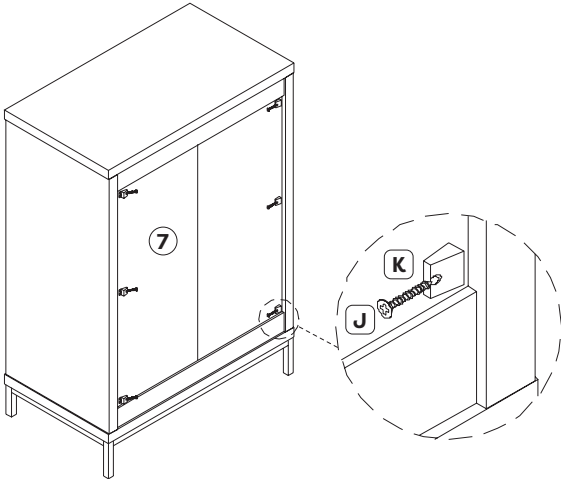

STEP 16

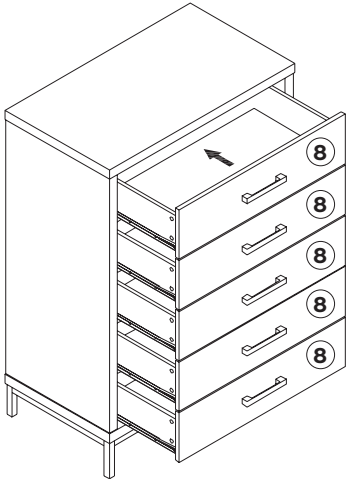

STEP 17

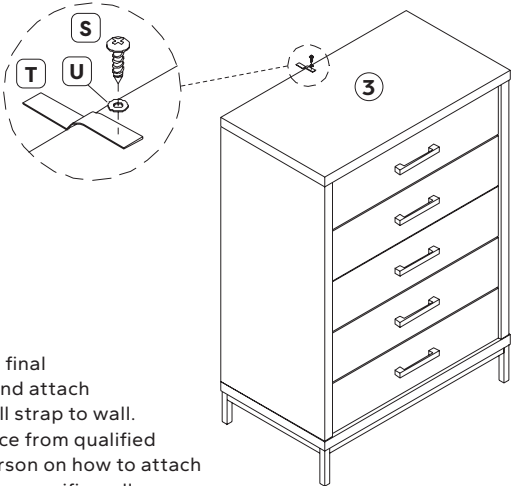

Move into final position and attach safety wall strap to wall. Seek advice from qualified trades person on how to attach this to your specific wall.

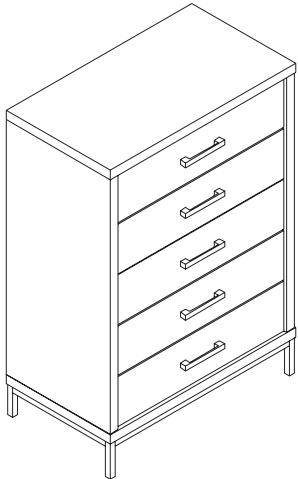



WARRANTY

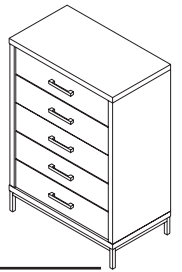

Subject to proof of purchase, Groove Furniture provides the following limited warranties to the original purchaser of Groove Furniture products purchased and used in Australia and New Zealand only on the following terms and conditions:

Standard 1 Year Warranty

Groove Furniture warrants that it will, at its option, repair or replace any cabinets, doors, shelves, drawers and various ancillary items (such as hardware components attaching to the cabinets, doors, drawers or shelves) that suffer a failure due to a defect in the materials or manufacturing process within one (1) year from the date of purchase.

Please note the Groove Furniture Warranty is not transferable or assignable.

For the warranty to apply

This warranty applies only to the original purchaser of Groove Furniture products used for normal, personal, domestic and household purposes only.

The original purchaser may obtain the benefit of this warranty on the following conditions:

1. The Groove Furniture product was purchased from an authorised Groove Furniture retailer and was paid for in full;
2. The original purchaser is able to provide an acceptable form of proof of purchase;
3. The Groove Furniture product was installed and is used in accordance with all supplied product information and instructions; and
4. Groove Furniture is notified within twenty-one (21) days of the alleged problem occurring.

Groove Furniture aims to rectify genuine warranty claims as a matter of priority. This is generally achieved by inspecting the product and determining the basis for the claim and by introducing immediate corrective action measures to prevent re-occurring problems. It is therefore essential that all warranty claims are promptly submitted to Groove Furniture within the twenty-one (21) day period of the alleged problem occurring as stated above.

This warranty represents the only warranty given by Groove Furniture and no other person or organisation is authorised to offer any alternative.

Exclusions and limitations

This warranty does NOT cover:

- Products without proof of purchase
- Products not purchased from an authorised Groove Furniture retailer
- Products which have not been paid for in full
- Products which are resold or resupplied or constitute second hand goods
- Normal wear and tear
- Usage other than normal personal, domestic or household use.
- Installation that is not in accordance with supplied installation instructions
- Defects which have been disclosed as a feature or limitation of the products in any literature published by Groove Furniture
- Variations in colour and shade



WARRANTY

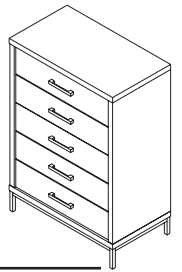

- Delamination
- General colour fading or discolouration or damage due to direct and indirect light (exposure to direct sunlight should be avoided)
- Slight variations or differences in the visual features of the products inherent within the manufacturing process.
- Accident, misuse, abuse, negligence, improper handling or failure to follow supplied care directions
- Exposure to excessive heat, moisture, ultra violet light or physical or chemical abuse (such as oven cleaners, floor and paint strippers and other harsh chemicals)
- Alteration, modification, repair or use of the product which is inconsistent with supplied product instructions
- Damage, problems or failure caused by acts of God, fire, wind, lightning, flood, storm, vandalism, earthquake, war, civil insurrection, pests, vermin, insects, spiders or interference by foreign objects or matter affecting the product such as dirt, debris, soot or moisture
- Damage, problems or failure caused by extreme weather conditions, including, but not limited to, hail, salt, or other harsh substances
- Products which have been installed in a portable or mobile building, structure or application including, but not limited to, a caravan or boat
- Products which are re-installed at a location other than the original installation site
- Inadequate support in the structure to which the product is installed
- Repairs to products without the authorisation of Groove Furniture in writing

If your Groove Furniture product has been discontinued, Groove Furniture may offer at its option a replacement with a similar Groove Furniture product. Groove Furniture does not warrant that replacement will fit any existing fixtures or chattels.

Groove Furniture does not warrant the removal, installation, deinstallation, reinstallation or set up costs or any other associated costs with a claim.

Groove Furniture does not warrant any consequential, incidental, direct or indirect loss, expense or damage suffered by you or any third party arising from or in relation to the use, installation, performance or failure of any Groove Furniture product

How to claim

To make a claim under this warranty, you must provide a copy of your original proof of purchase and proof of installation to enable us to determine whether your Groove Furniture product falls within the warranty and the relevant warranty periods. This will also help us determine whether the claim made is genuine and is not based on any breach of warranty or any violations of the law, such as those involving lost, stolen, counterfeit or second hand goods.

The acceptable proof of purchase is a tax invoice or receipt that clearly itemises the product and shows the date and place of purchase and, if applicable, information pertaining to the installation of your Groove Furniture product. As a strict condition, where there is no acceptable form of proof of purchase, Groove Furniture undertakes no responsibility to repair the product under warranty.

You will need to contact Groove Furniture during the applicable warranty period on the contact details provided below. To enable Groove Furniture to correctly identify and rectify the problem, please be ready to provide accurate details of your Groove Furniture product and finish, date of purchase, date of installation (if applicable), purchase details and a full description of the problem. Our customer service representatives will let you know what other information is required for processing your claim. Importantly, you will need to arrange with Groove Furniture clear images of your product as part of our assessment of your claim.

Please bear in mind, you will be responsible for all expenses involved in contacting Groove Furniture to make your claim under this warranty and Groove Furniture will bear the expenses of any review and processing of your claim.



WARRANTY

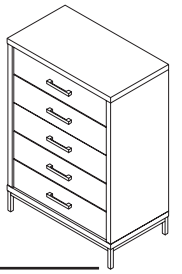

By email at
groove@austbrush.com.au

By telephone in Australia
1800 666 078
Monday to Friday
From 8:00am to 6:00pm AUEST

How Groove Furniture will fulfil warranty claims

Groove Furniture will honour all valid claims made under this warranty by either repairing or replacing (at Groove Furniture's option) your Groove Furniture product.

You may be charged

You MAY BE CHARGED for work done or any service call(s) if:

- The problem is not covered by this warranty
- There is nothing wrong with the product
- You are unable to provide acceptable proof of purchase and decide to proceed with your claim

We strongly recommend that you read all instructions supplied upon purchase of your Groove Furniture product before making a warranty claim.

Other rights

The benefits provided to you under this warranty are in addition to any other rights or remedies you may have as a consumer under any other law which applies to our products.

Our goods and services come with guarantees that cannot be excluded under the Australian Consumer Law. For major failures with the service, you are entitled:

- to cancel your service contract with us; and
- to a refund for the unused portion, or to compensation for its reduced value.

You are also entitled to choose a refund or replacement for major failures with goods. If a failure with the goods or a service does not amount to a major failure, you are entitled to have the failure rectified in a reasonable time. If this is not done you are entitled to a refund for the goods and to cancel the contract for the service and obtain a refund of any unused portion. You are also entitled to be compensated for any other reasonably foreseeable loss or damage from a failure in the goods or service.



WARRANTY

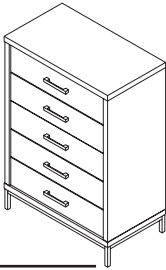

Checklist to be completed and submitted to Groove Furniture when making a claim

Your name: _____

Your address: _____

Your telephone number: _____

Your authorised Groove Furniture retailer: _____

Your authorised Groove Furniture retailer's address: _____

Your authorised Groove Furniture retailer's phone number: _____

Product model number (if applicable): _____

Product serial number (if applicable): _____

Date of installation (if applicable): _____

Installed by (if applicable): _____

Installer's address (if applicable): _____

Have you provided a copy of your proof of purchase (please circle)? Yes / No

Provide a brief description of your claim, including the problem and when you found out about it:

Have you provided any photographs of the product (please circle)? Yes / No

Dated: _____ Signed: _____