

AUSTIN WRITING DESK

STEP 1

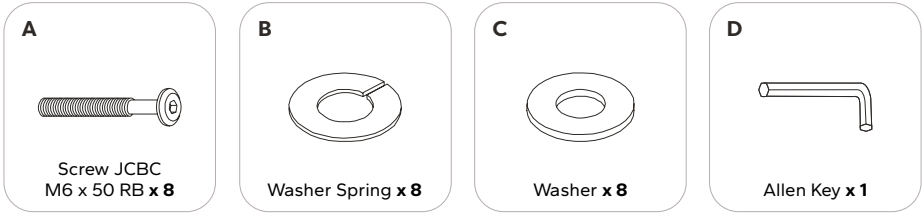

Check included hardware.

STEP 2

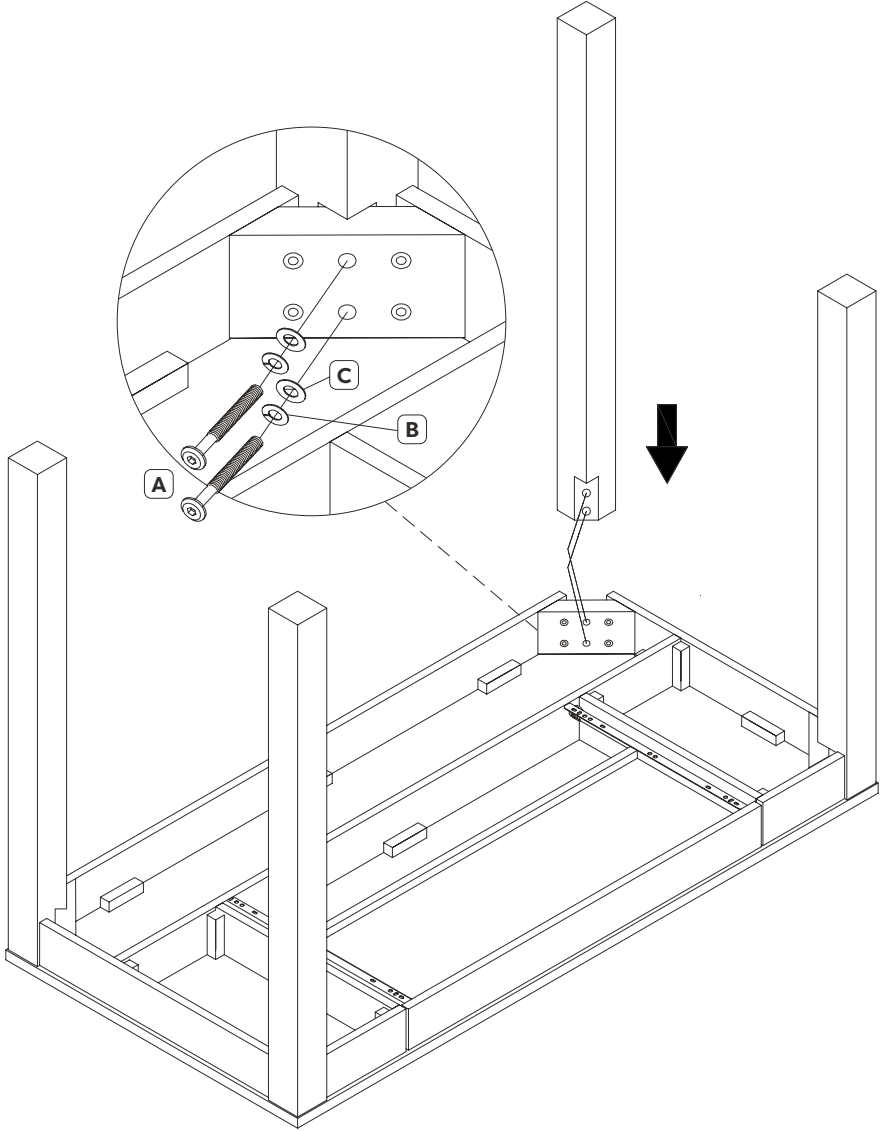

Attach table legs to pre-assembled table top. Using allen key (D) provided, thread washer spring (B) and washer (C) through M6 x 50 screw (A) on centre two holes of leg. Tighten using the allen key (E) provided.

Caution:
This item is made of laminated particle board and medium density fibre board to be assembled on a dry, soft, smooth and clean surface. Do not use detergent or chemical. Avoid damp and direct sunlight.