ASSEMBLY INSTRUCTIONS

PLATINUM SERIES

ROMAN CHAIR / HYPER EXTENSION

SKU: CPL-ROC-1043





CAUTION: Read all precautions and instructions before using this equipment. Save this manual for future reference.



COMPOUND
FITNESS EQUIPMENT

Table Of Contents

Assembly Instructions.....	2-7
Part List.....	8

STEP 1

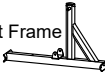
Tools	
	17 mm
	8 mm

Parts	
Part No: 1 Name: Pedal Frame Q'TY:1	
Part No: 2 Name: Upright Frame Q'TY:1	
Part No: 3 Name: Hole Cap D25 Q'TY:1	

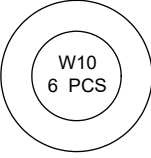
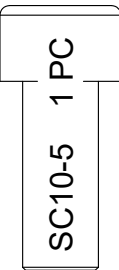
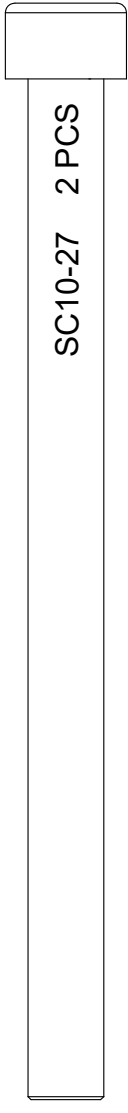
Fixings	
	N 10 3 PCS
	W10 6 PCS
	SC10-5 1 PC
	SC10-27 2 PCS

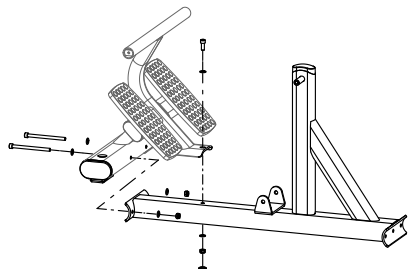

Assemble the Pedal Frame(#1) and the Upright Frame(#2).

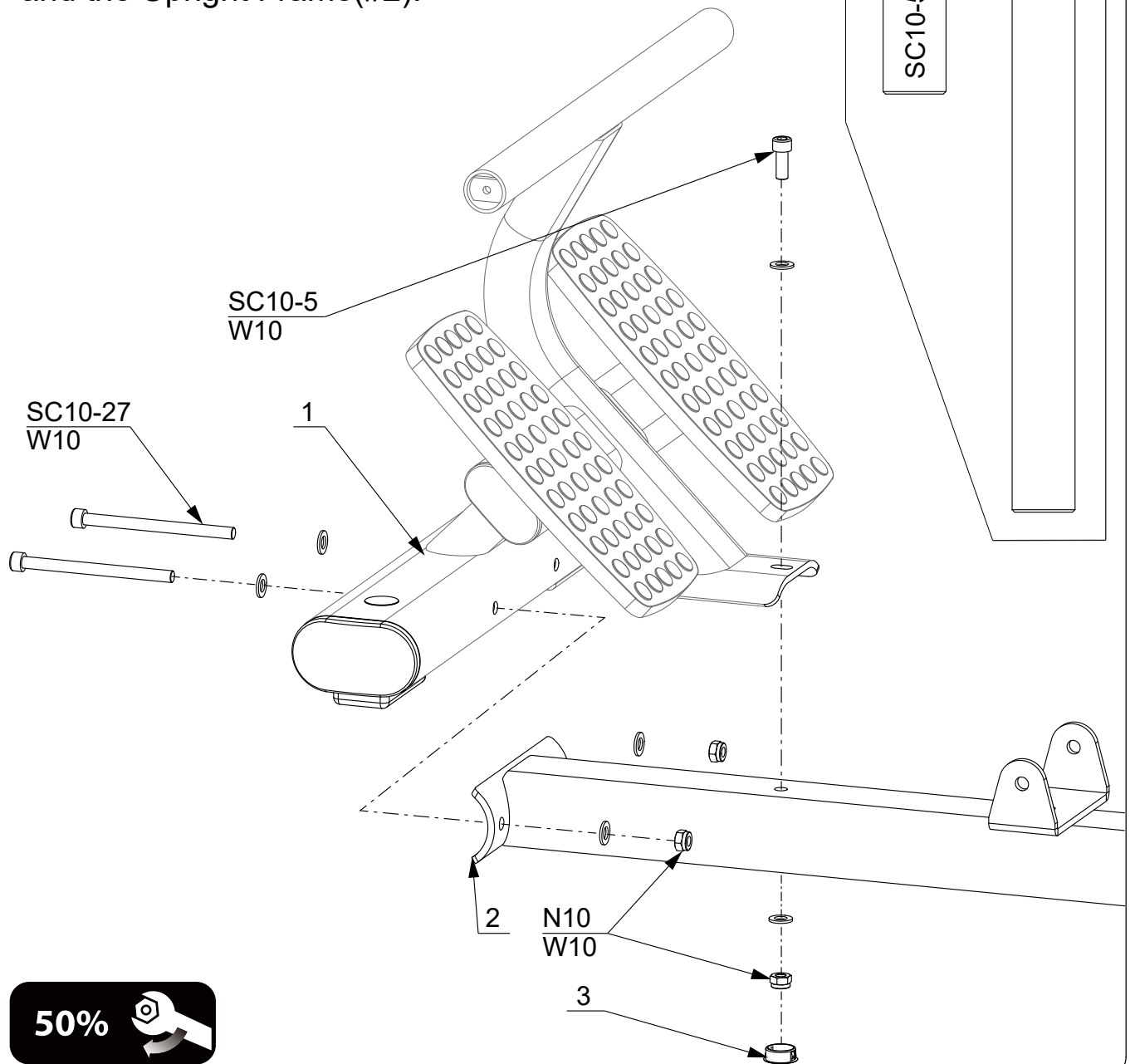

STEP 2

Tools

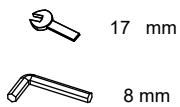

Parts

Part No:4
Name: Bottom Lateral
Bent Tube
Q'TY:1

Fixings

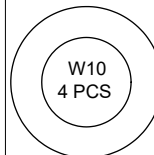
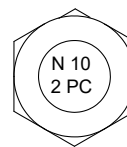

SC10-27 2 PC

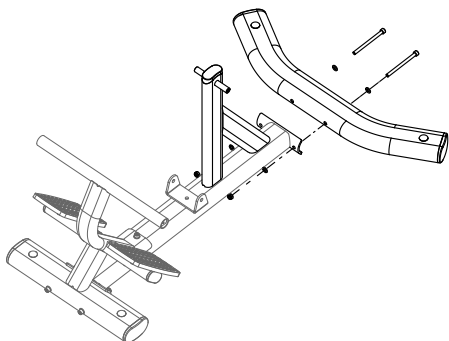

Assemble the Bottom Lateral Bent Tube(#4) and the Upright Frame(#2).

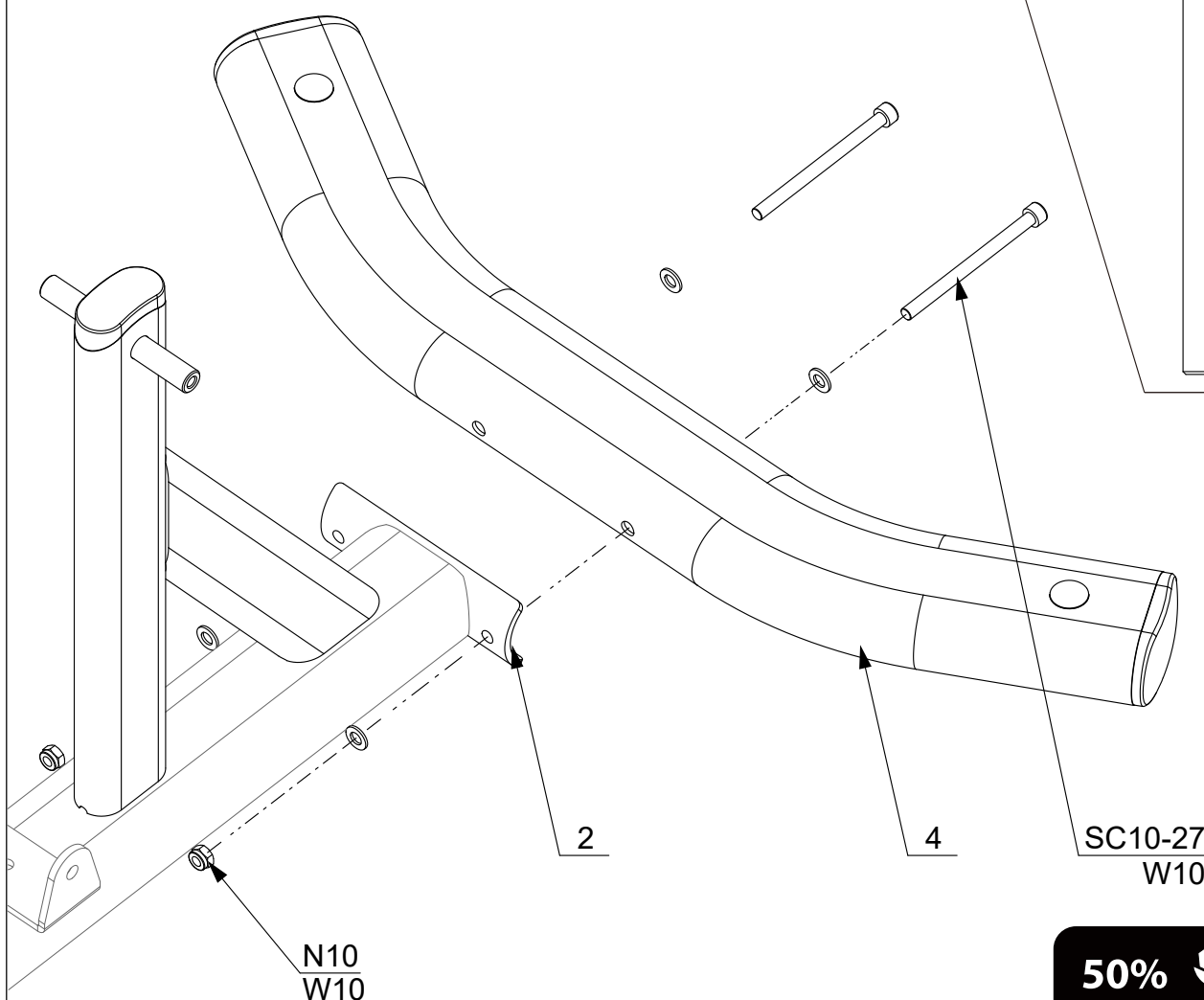

50%



STEP 3

Tools



6 mm

Parts

Part No:5
Name: Pivot Arm
Q'TY:1



Part No:6
Name: Shaft
Q'TY:1



Fixings

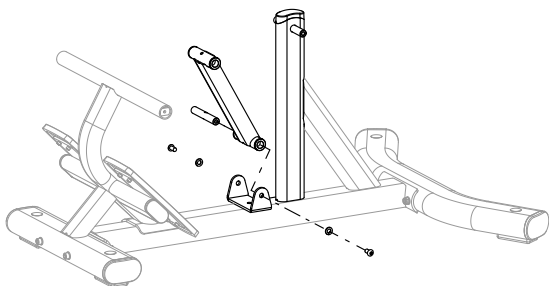
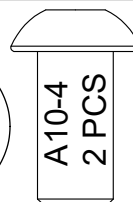
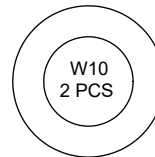

Assemble the Pivot Arm(#5) and the Upright frame(#2).

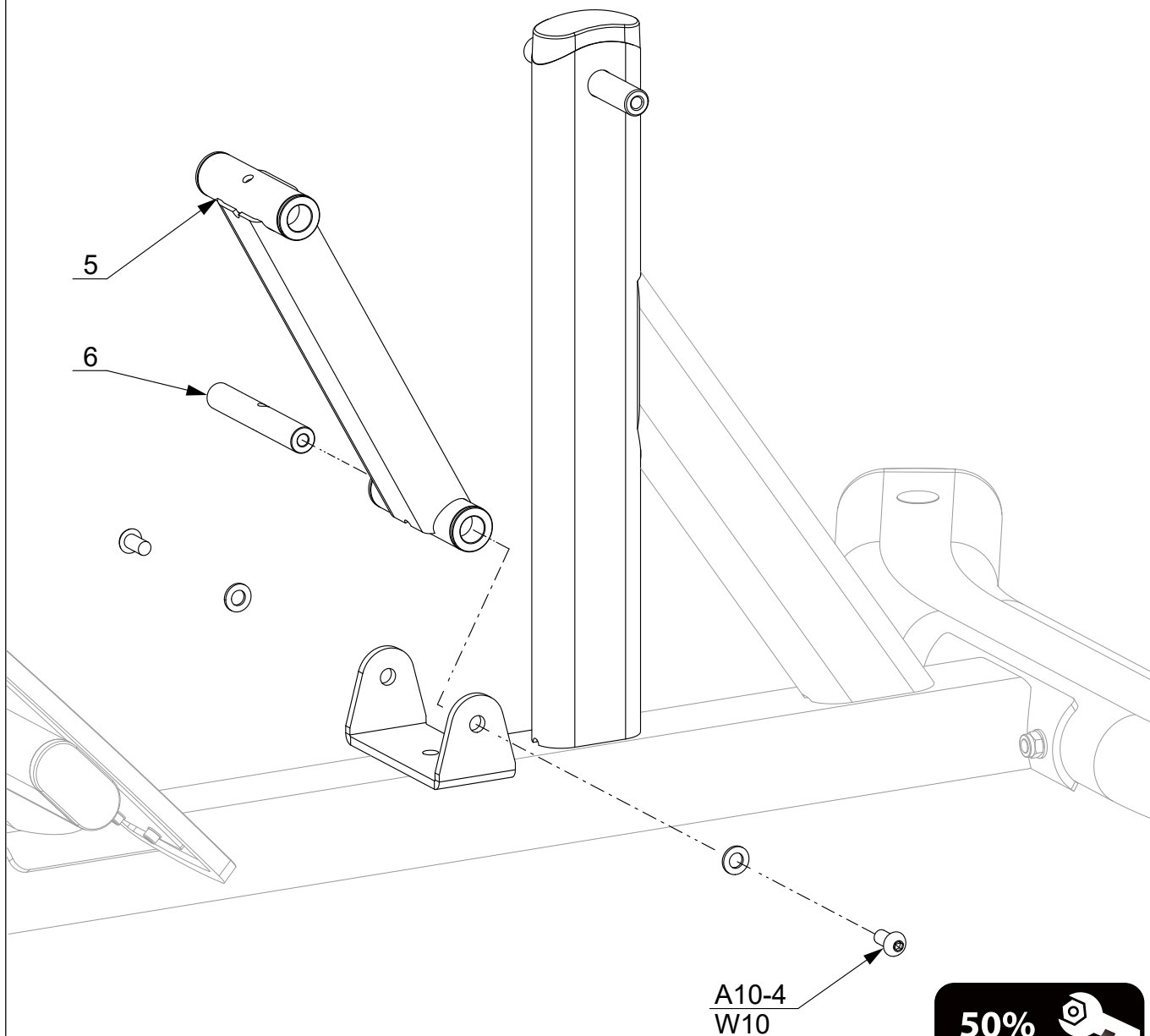

50%



STEP 4

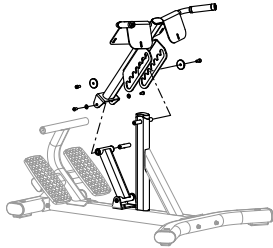

Tools



8 / 6 mm

Parts

Part No: 7
Name: Thigh Support Frame
Q'TY:1
Part No:8
Name:Big Washer
Q'TY:2
Part No:6
Name:Shaft
Q'TY:1



Fixings

SC10-4 2 PCS

A10-4 2 PCS

2 PCS

W10

Assemble the Thigh Support Frame(#7) ,
Pivot Arm (#5)and the Upright Frame(#2).

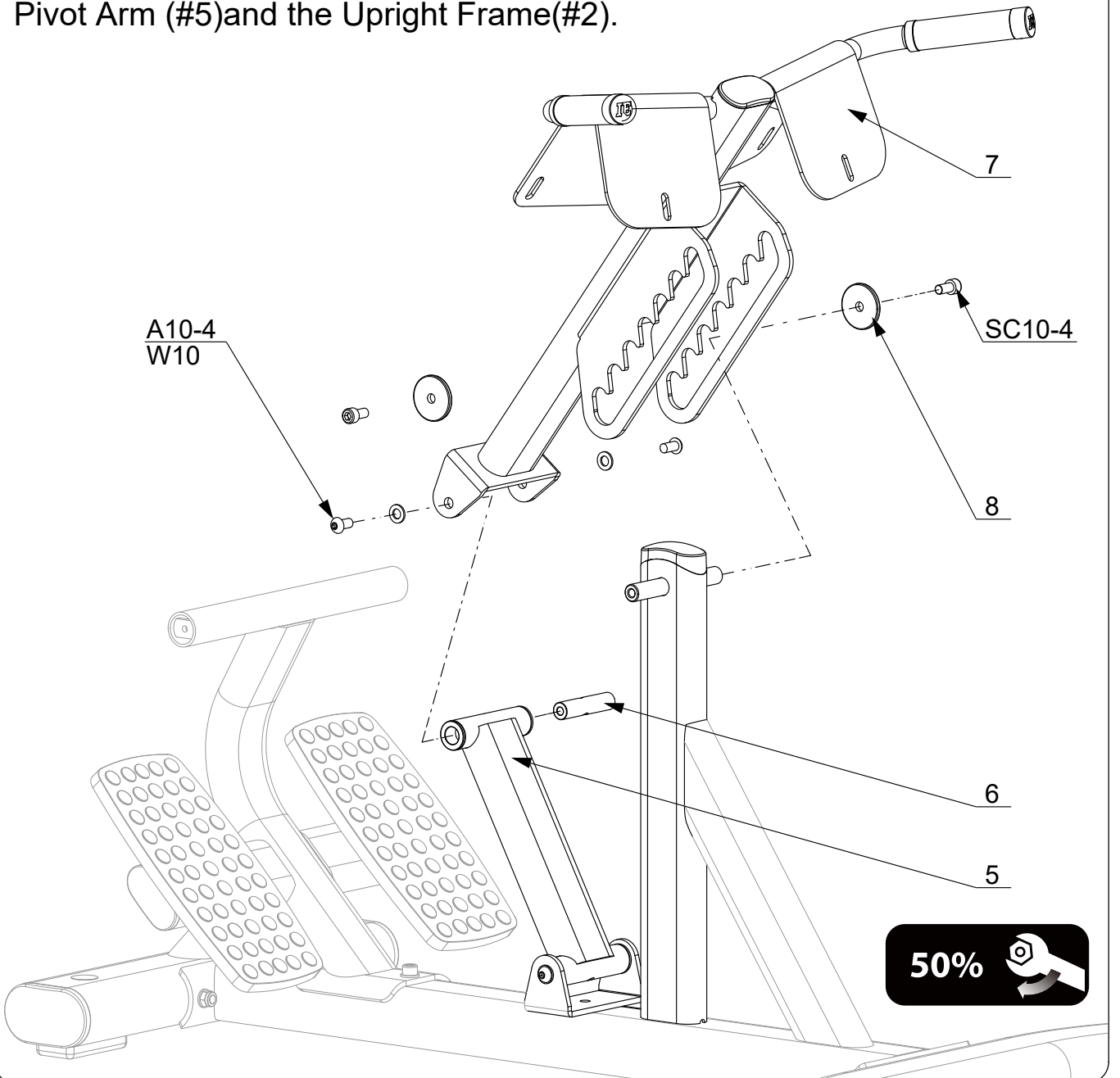

STEP 5

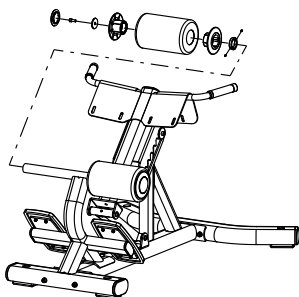

Assemble the Foam Roller.

Tools



6 / 3 mm

Fixings

S6-2 4 PCS



SC 8-4 2 PCS

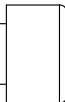

Parts

Part No:9
Name: Inner Retaining Ring
Q'TY:2



Part No:10
Name: Roller Bushing
Q'TY:4



Part No:11
Name: Foam Roller
Q'TY:2



Part No:12
Name: Big Washer OD45
Q'TY:2

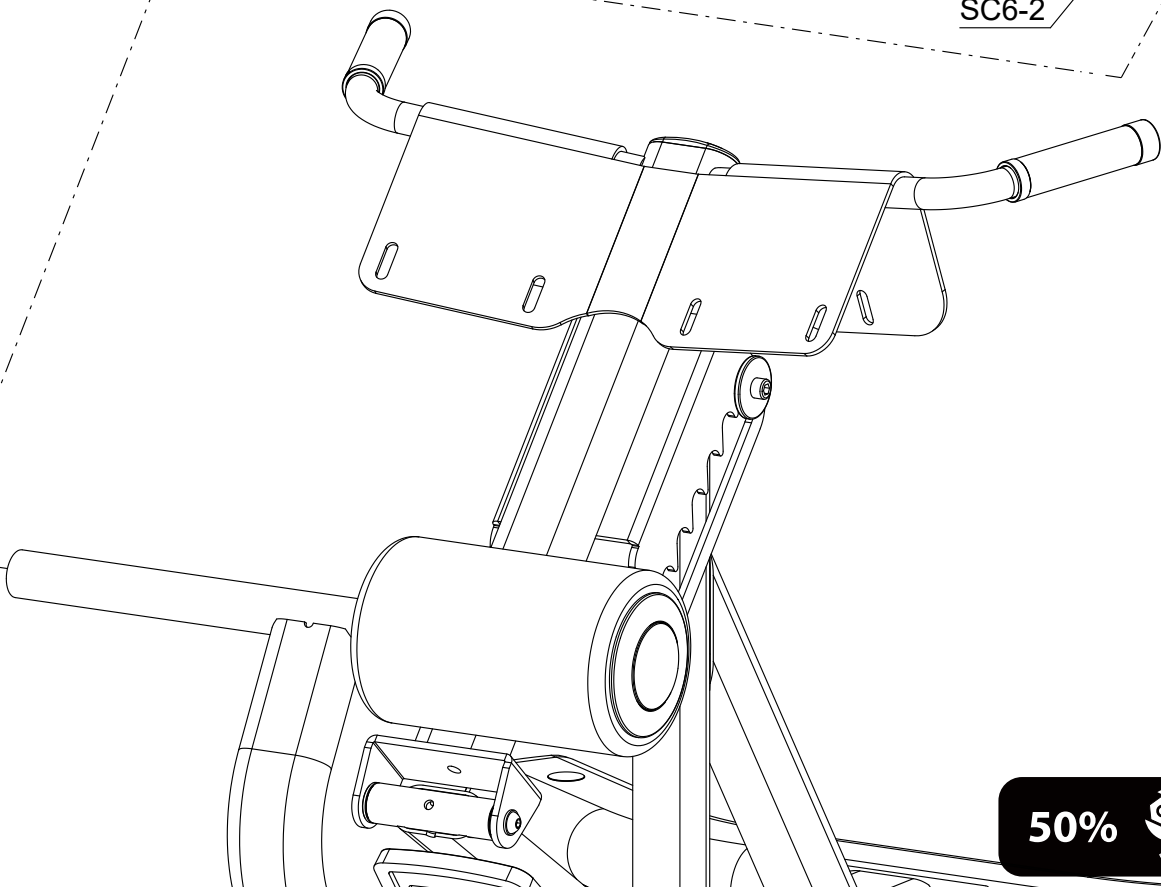
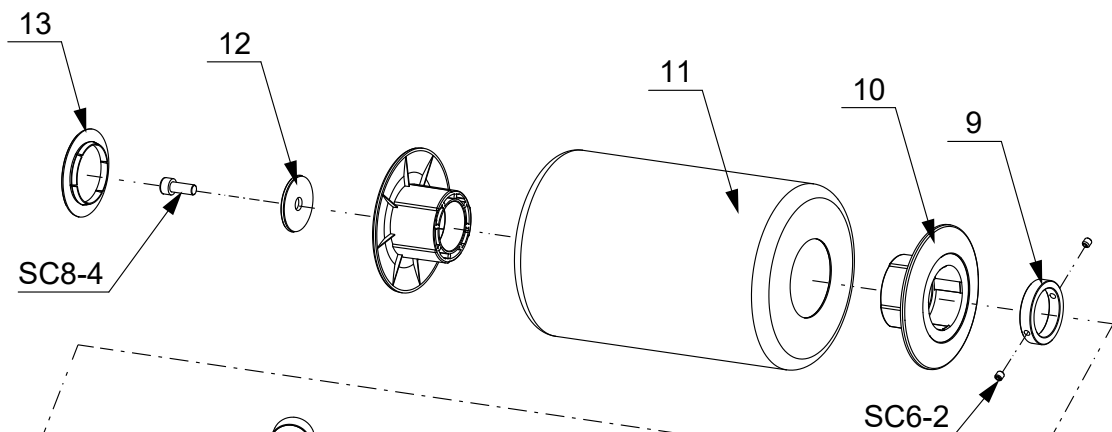

Part No:13
Name: Roller Cap
Q'TY:2

50%



STEP 6

Tools



6 mm

Parts

Part No:14
Name: Thigh Pad
Q'TY: 2



Fixings

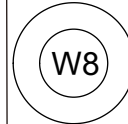

6 PCS

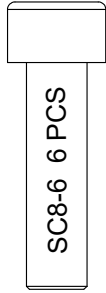

SC8-6 6 PCS

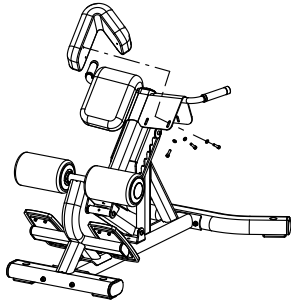

Fix the thigh pad(#14) to the thigh support frame(#7).

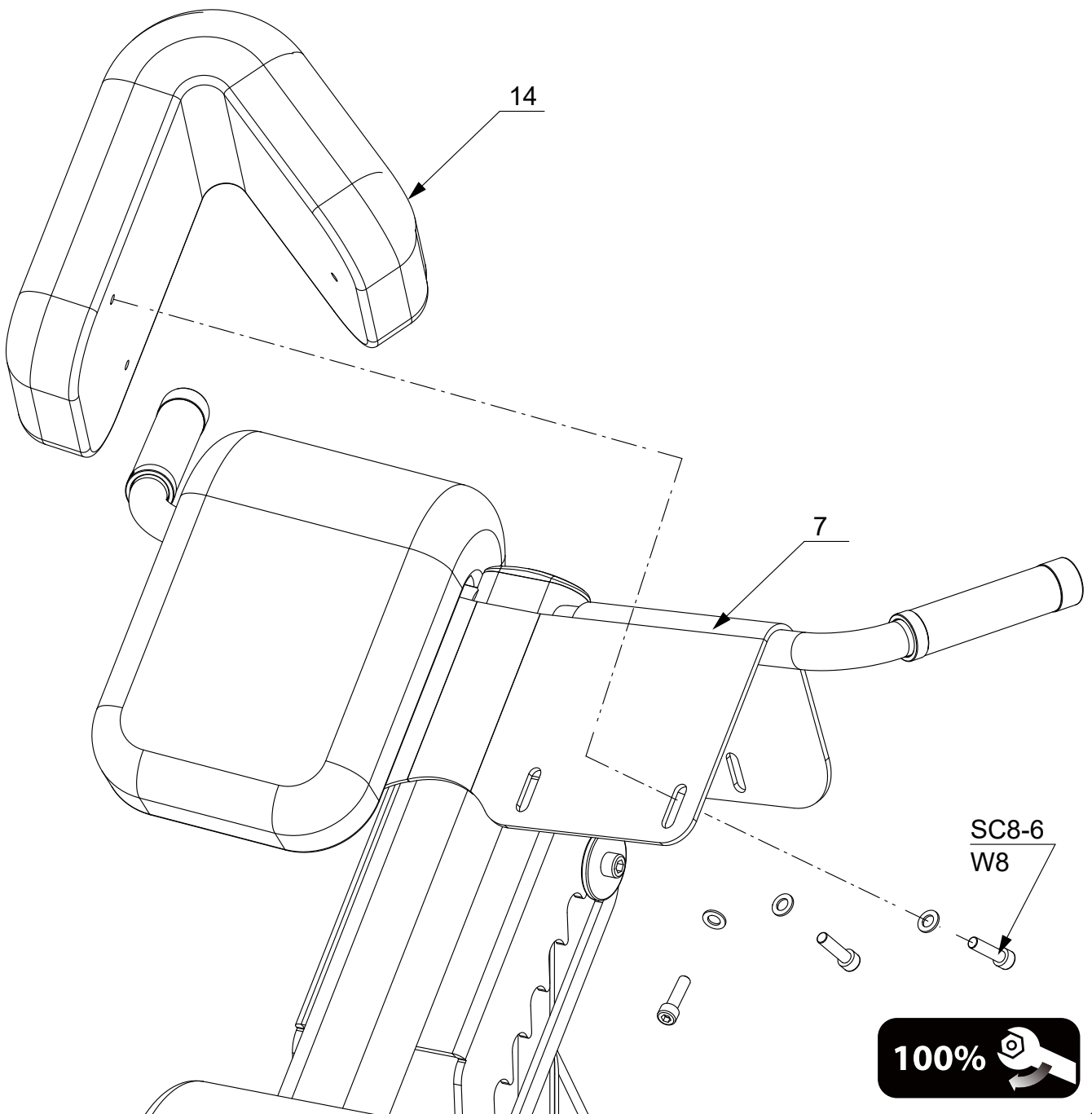

100%



PARTS LIST

PART NO.	DESCRIPTION	QT'Y
1	Pedal Frame	1
2	Upright Frame	1
3	Hole Cap D25	1
4	Bottom Lateral Bent Tube	1
5	Pivot Arm	1
6	Shaft	2
7	Thigh Support Frame	1
8	Big Washer	2
9	Inner Retaining Ring	2
10	Roller Bushing	4
11	Foam Roller	2
12	Big Washer OD45	2
13	Roller Cap	2
14	Thigh Pad	2
W8	Washer 8	6
W10	Washer 10	14
N10	Nut M10	5
A10-4	Button Head Screw	4
S6-2	Socket Set Screw M6×6	4
SC8-4	Socket Head Cap Screw M8×20	2
SC8-6	Socket Head Cap Screw M8×30	6
SC10-4	Socket Head Cap Screw M10×20	2
SC10-5	Socket Head Cap Screw M10×25	1
SC10-27	Socket Head Cap Screw M10×135	4