

ASSEMBLY INSTRUCTIONS

PLATINUM SERIES

BELT SQUAT PLATE LOADED MACHINE

SKU: CPL-BSM-2126

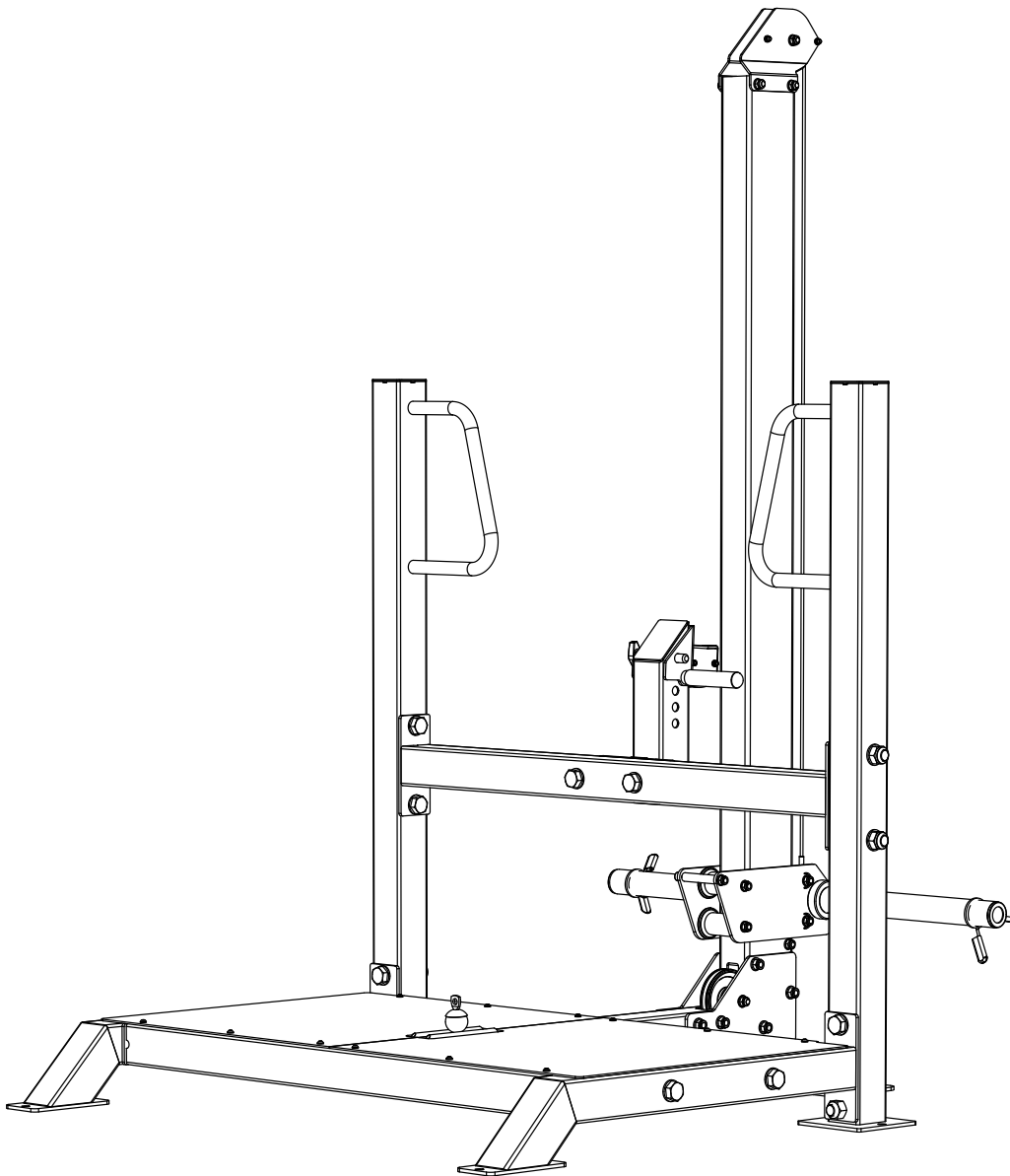

CAUTION: Read all precautions and instructions before using this equipment. Save this manual for future reference.

COMPOUND
FITNESS EQUIPMENT

Table Of Contents





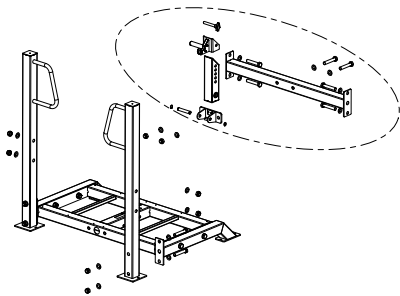

Assembly Instructions.....	2-09
Part List.....	10

STEP 1



Assemble The Holding Hook Group(#12) With The Pivoted Tube Assy (#10), Then Assemble (4#) With Them.



Parts

-  Part No: 4
Name: Transverse Tube Assy
Q'TY: 1
-  Part No: 7
Name: External Circlip
Q'TY: 2
-  Part No: 8
Name: Shaft
Q'TY: 1
-  Part No: 9
Name: Bracket
Q'TY: 1
-  Part No: 10
Name: Pivoted Tube Assy
Q'TY: 1
-  Part No: 12
Name: Holding Hook Assy
Q'TY: 1
-  Part No: 13
Name: Retaining Pin
Q'TY: 1

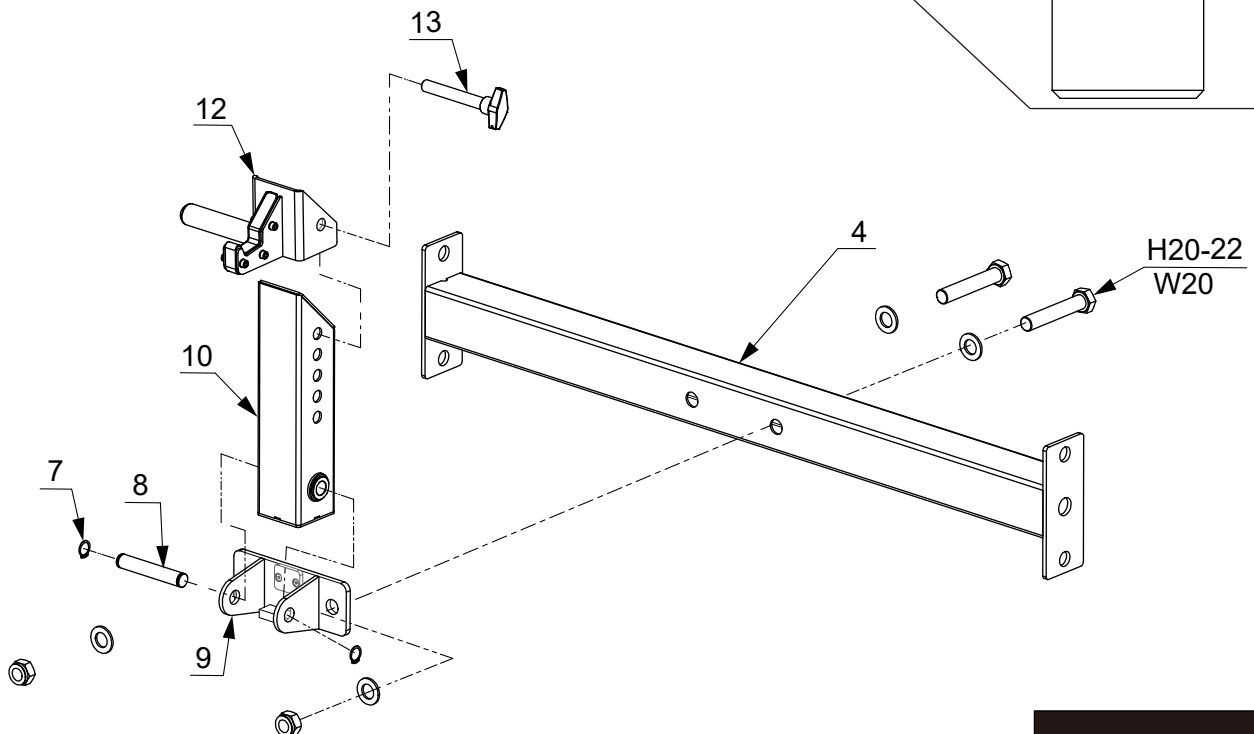
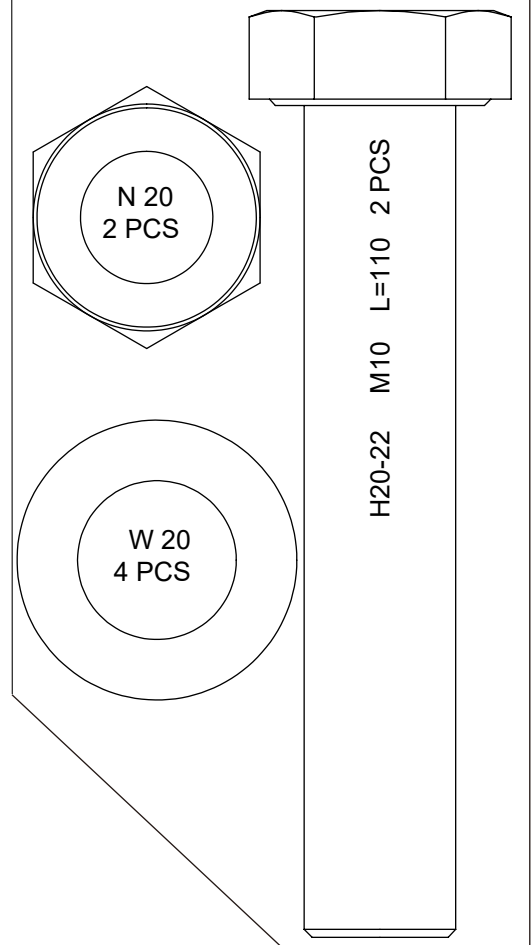
Fixings



Tools

-  30 mm
-  External Circlip Pliers

50%



STEP 2

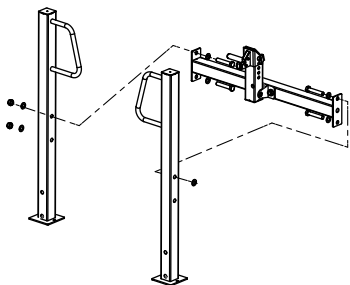

Parts



Part No: 1
Name: Upright Tube
Q'TY: 2

Fixings

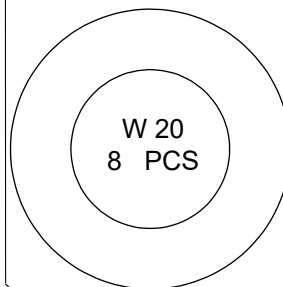
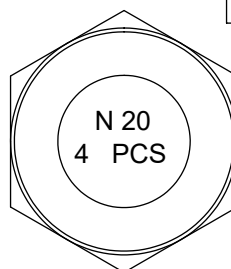

H20-22 M10 L=110 4 PCS

Assemble The Part Of Step 1 With The Upright Tube(#1).

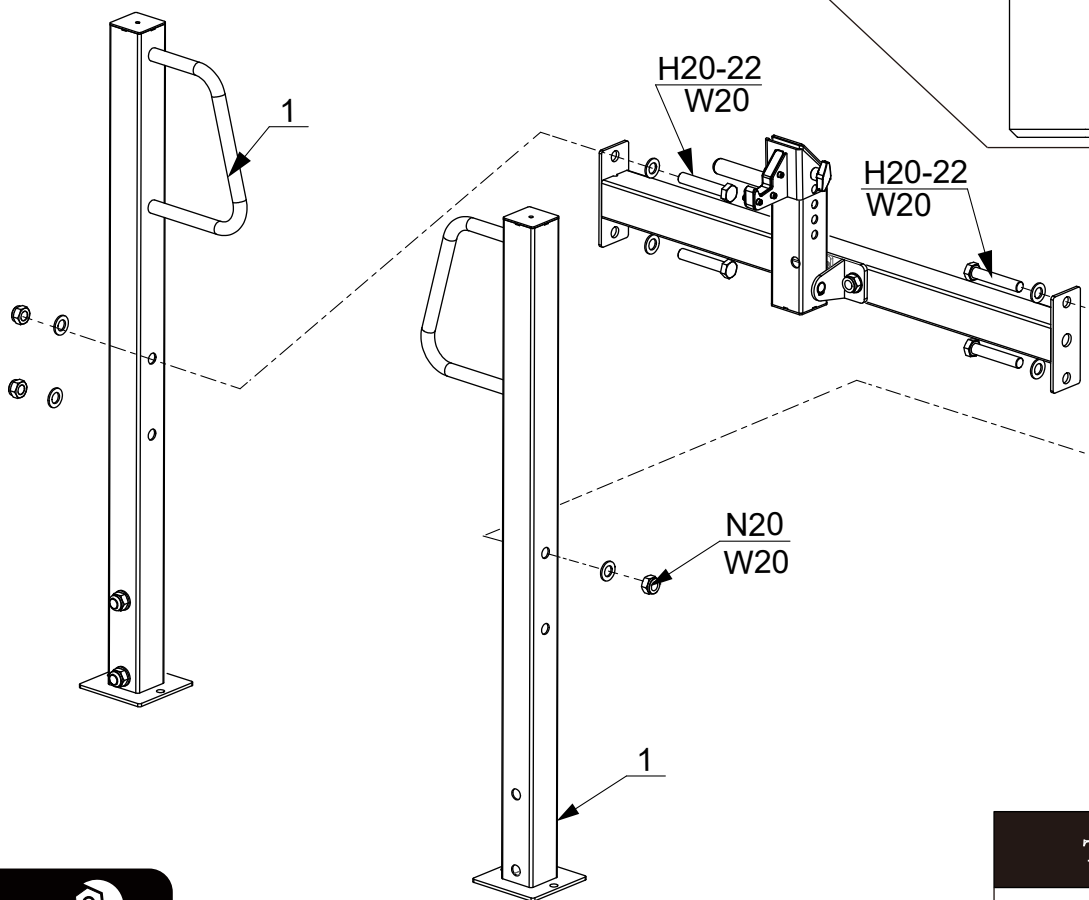

50%



Tools



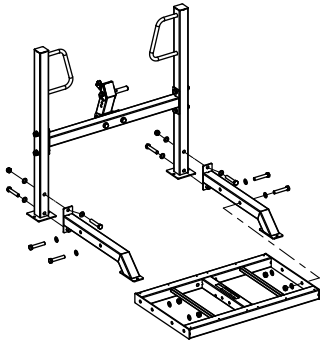

30 mm

STEP 3



Parts

-  Part No: 1
Name: Upright Tube
Q'TY: 2
-  Part No: 2
Name: Bottom Side Tube
Q'TY: 2
-  Part No: 3
Name: Platform Frame Assy
Q'TY: 1

Fixings

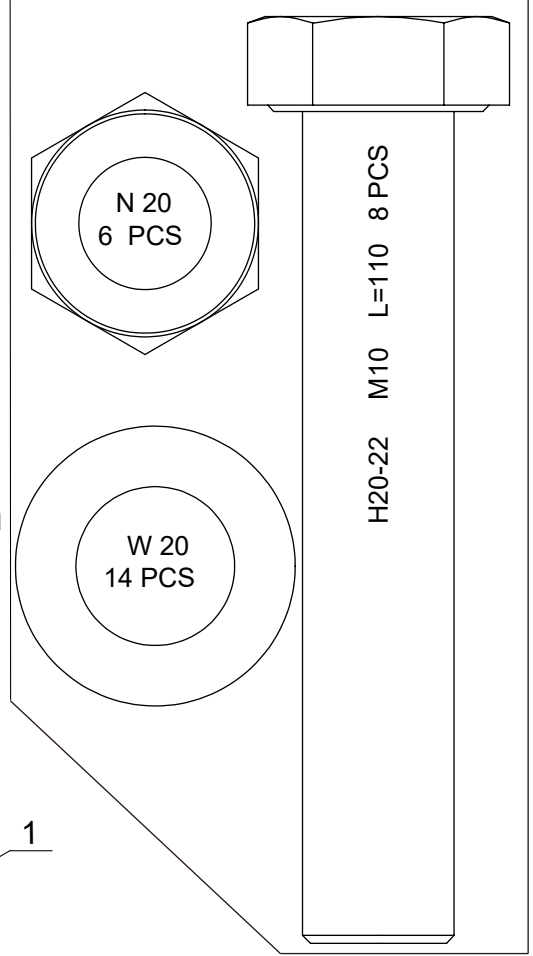

Assemble Platform Frame Assembly(#3)
And (Both Side) Bottom Side Tube(#2) On
The Upright Tube(#1).

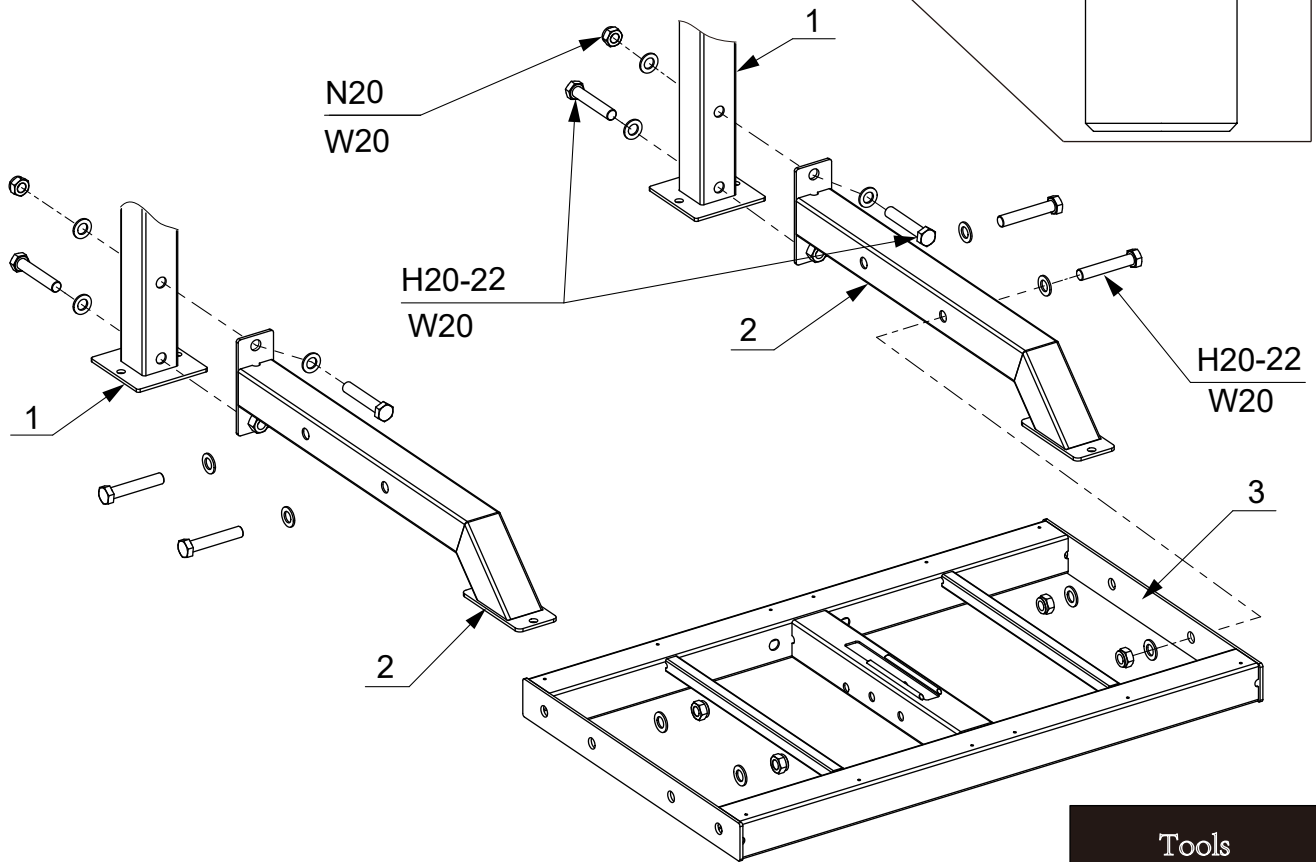

Tools



30 mm

50%



STEP 4

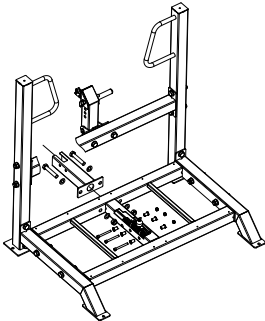

Install The Cable,
And The Bottom
Pulleys

Parts	
	Part No: 27 Name: Spacer 1 Q'TY: 6
	Part No: 22 Name: Cable Q'TY: 1
	Part No: 14 Name: Connection Tube Assy Q'TY: 1
	Part No: 11 Name: 70 Pulley Q'TY: 1
	Part No: 5 Name: 89 Pulley Q'TY: 2

Tools	
	16(17) \ 30 mm
	8 mm

Fixings	
	W 20 4 PCS
	N 20 2 PCS
	N 10 3 PCS
	SC10-18 M10 L=90 3 PCS
	H20-22 M10 L=110 2 PCS

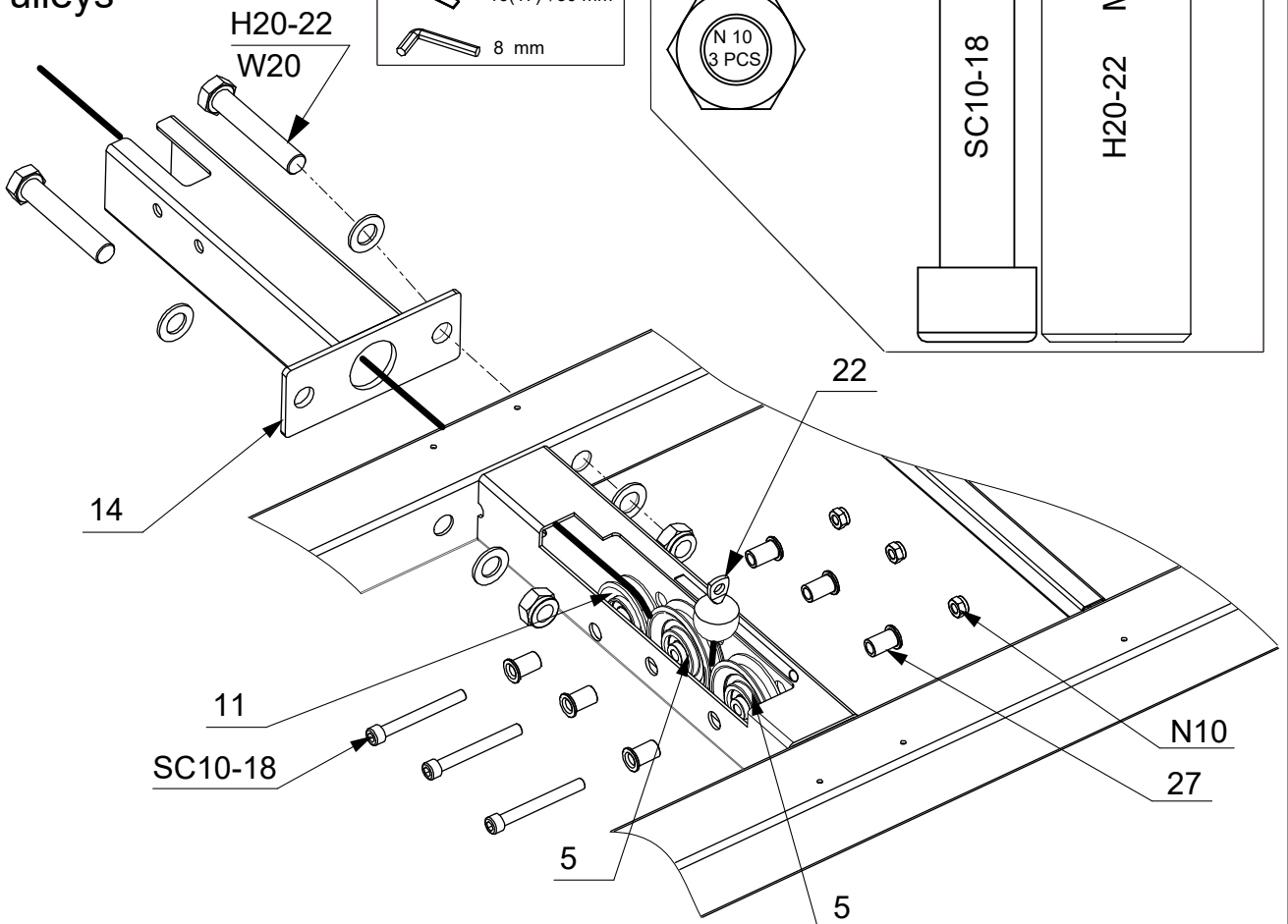

Sectional View

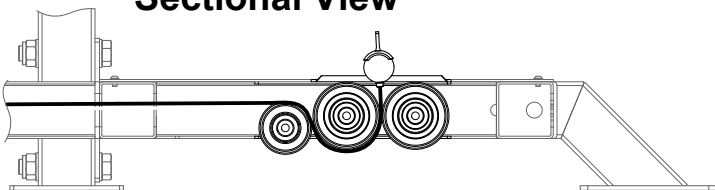

STEP 5

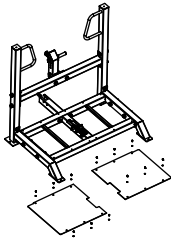

Tools



4 mm

Parts



Part No: 15
Name: Pedal 2
Q'TY: 1



Part No: 6
Name: Pedal 1
Q'TY: 1

Fixings



Q'TY: 12

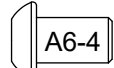

Q'TY: 12

Install The Pedals.

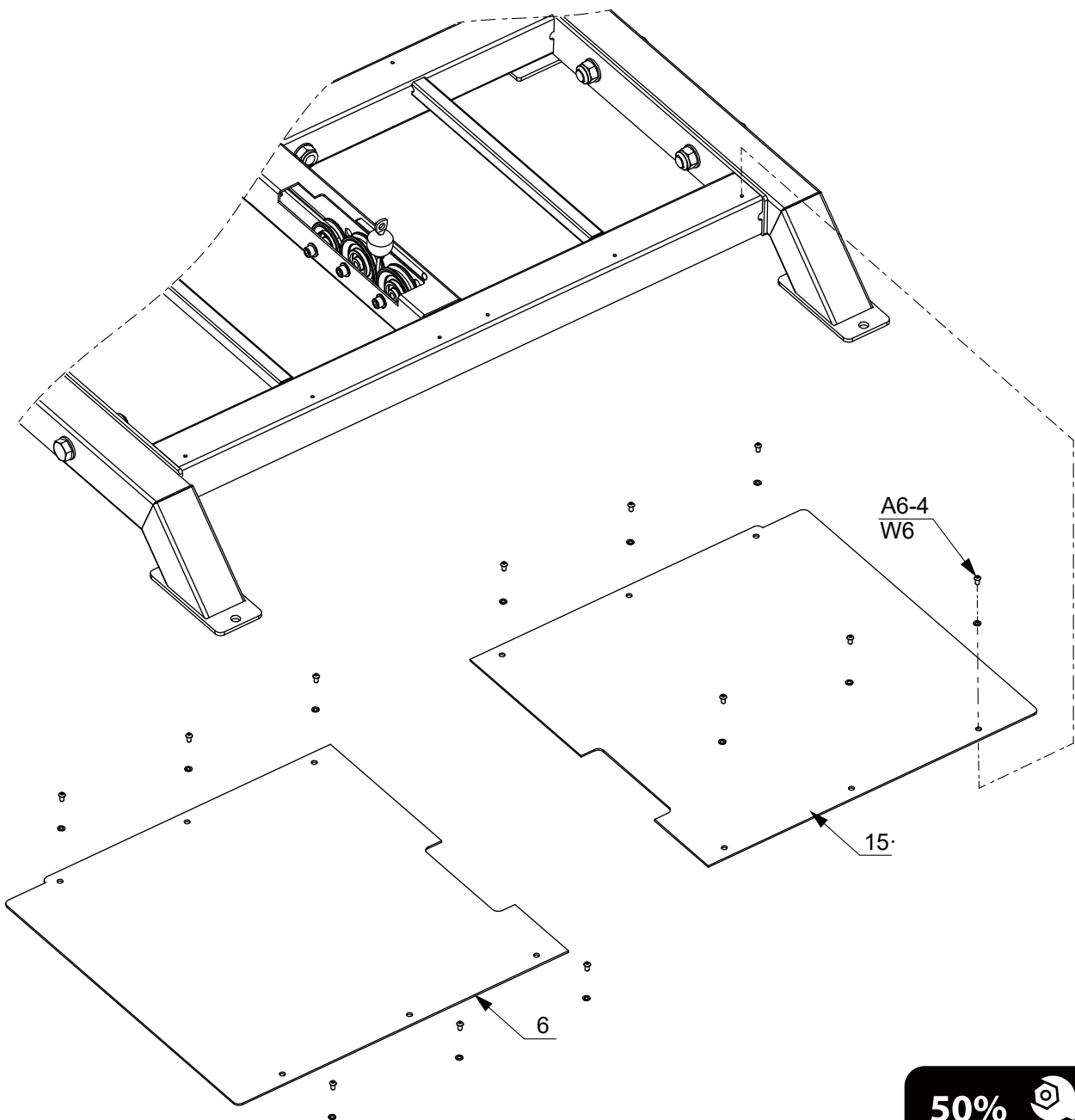





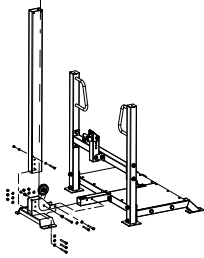

50%



STEP 6

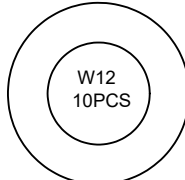
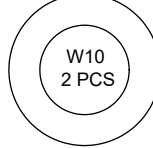

Parts	
	Part No: 17 Name: 114 Pulley Q'TY:1
	Part No: 20 Name: Guide Tube Q'TY:1
	Part No: 21 Name: Spacer 2 Q'TY:2
	Part No: 23 Name: Pedestal Assy Q'TY:1

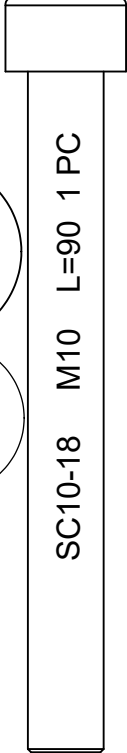
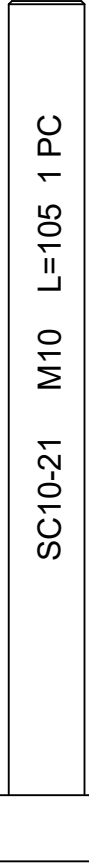
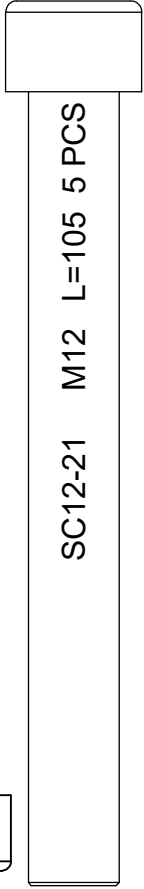

Fixings	
	N 12 5PCS
	W12 10PCS
	W10 2 PCS
	N 10 2 PCS
	SC10-18 M10 L=90 1 PC
	SC10-21 M10 L=105 1 PC
	SC12-21 M12 L=105 5 PCS

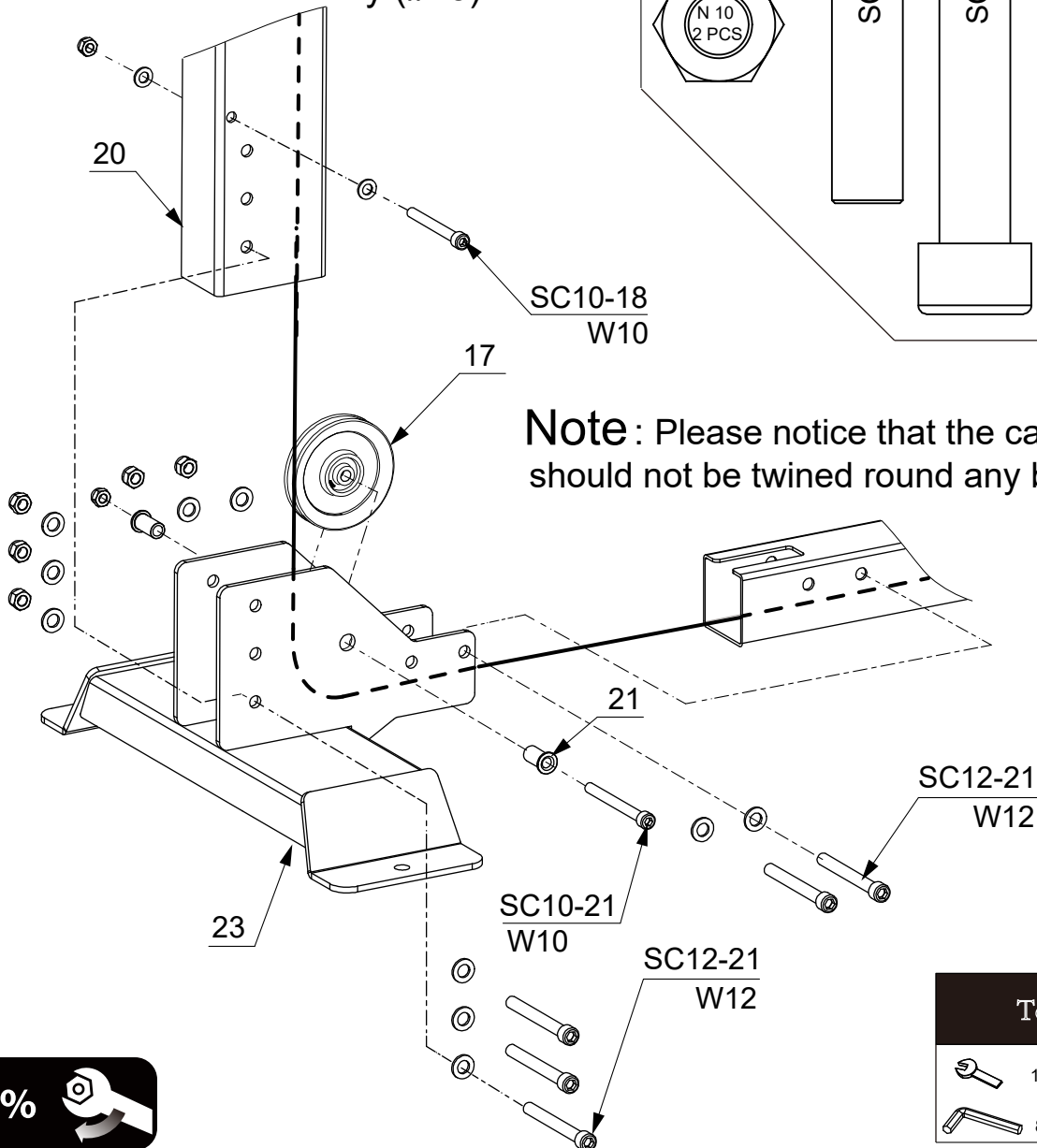
Install The Guide Tube(#20) & Pulley(#17) On The Pedestal Assembly (#23).





Note: Please notice that the cable should not be twined round any bolts.





Tools	
	16(17) \ 19 mm
	8 \ 10 mm

STEP 7

Tools	
	16(17) mm

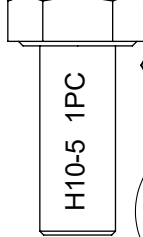
Parts	
	Part No: 24 Name: Barbell Holder Set Q'TY: 1
	Part No: 25 Name: Barbell Clip Q'TY: 1

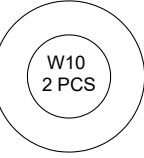
Fixings	
	H10-5 1PC
	N 10 1 PCS
	W10 2 PCS

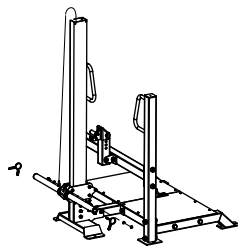

Install The Barbell Holder Set(#24)
On The Guide Tube(#20).

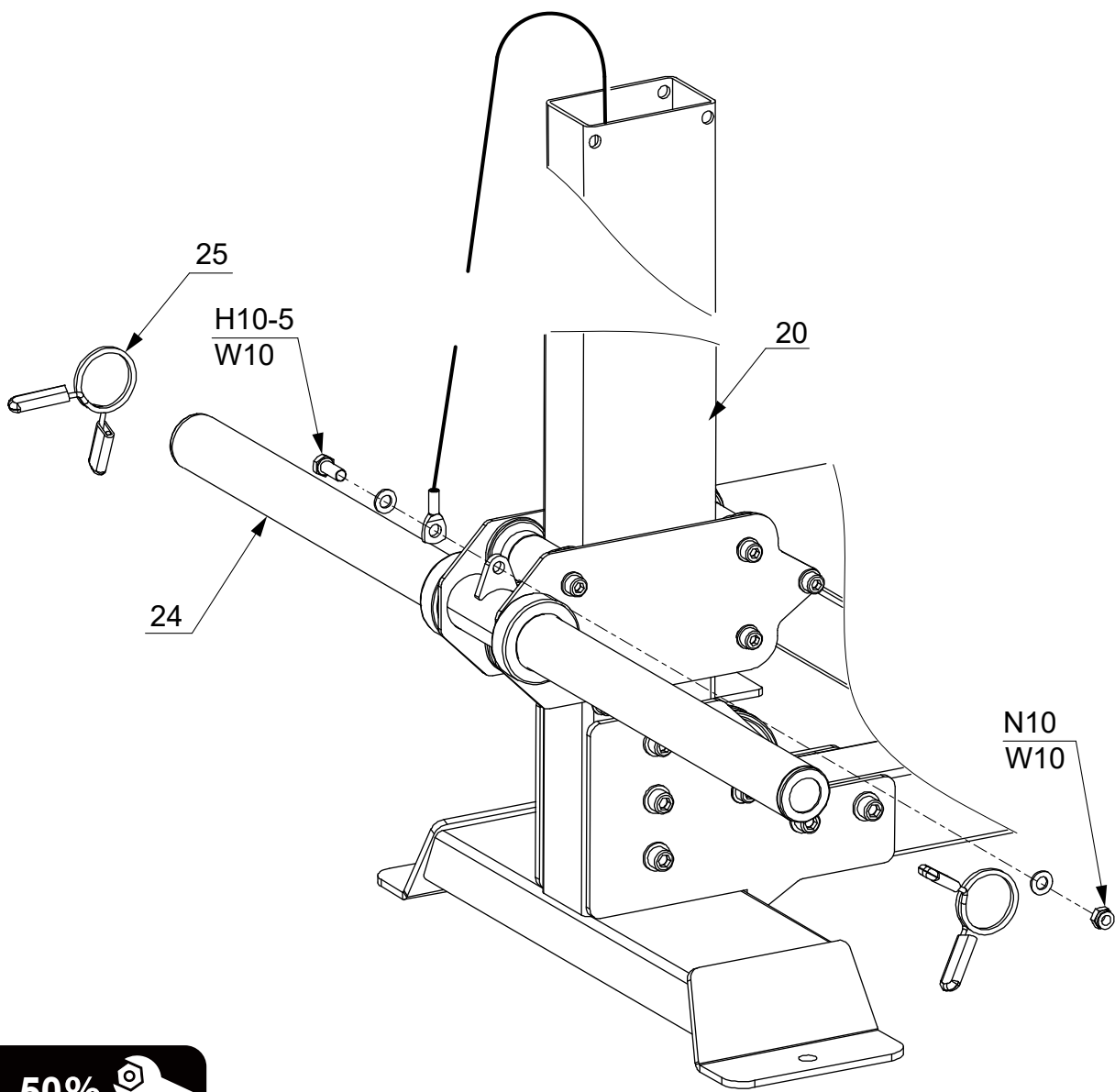

50% 



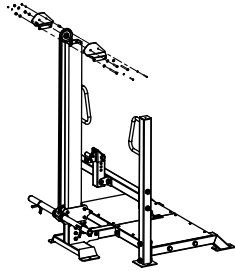

STEP 8

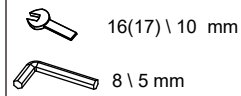

Tools



Parts

-  Part No: 16
Name: Pulley Bracket 1
Q'TY: 1
-  Part No: 17
Name: 114 Pulley
Q'TY: 1
-  Part No: 18
Name: Limit Tube
Q'TY: 2
-  Part No: 19
Name: Pulley Bracket 2
Q'TY: 1

Fixings

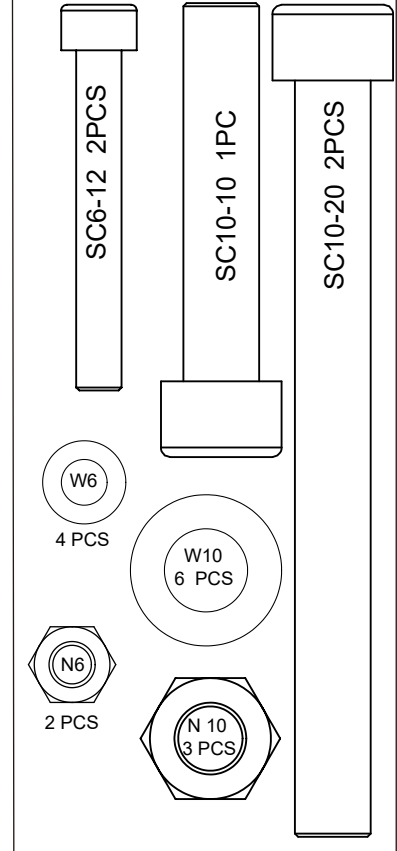

Install Pulley Bracket(#16 & #19)
And 114 Pulley(#17) On The Top
Of The Guide Tube(#20).

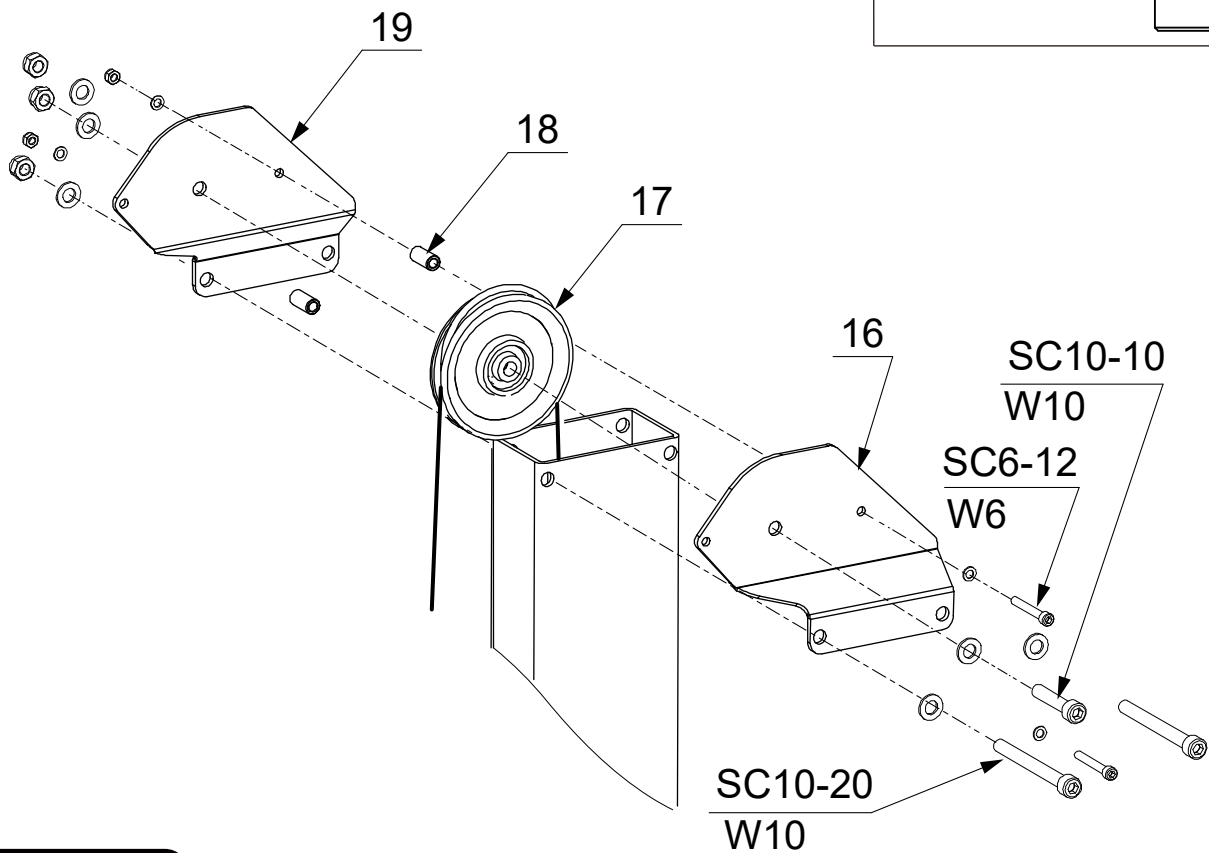

100% 

PARTS LIST

PART NO.	DESCRIPTION	QTY
1	Upright Tube	2
2	Bottom Side Tube	2
3	Platform Frame Assembly	1
4	Transverse Tube Assembly	1
5	89 Pulley	2
6	Pedal 1	1
7	External Circlip	2
8	Shaft	1
9	Bracket	1
10	Pivoted Tube Assembly	1
11	70 Pulley	1
12	Holding Hook Assy	1
13	Retaining Pin	1
14	Connection Tube Assembly	1
15	Pedal 2	1
16	Pulley Bracket 1	1
17	114 Pulley	2
18	Limit Tube	2
19	Pulley Bracket 2	1
20	Guide Tube	1
21	Spacer 2	1
22	Cable L=4360 mm	1
23	Pedestal Assembly	1
24	Barbell Plate Holder	1
25	Weight Bar Clamp	2
*		
27	Spacer 1	6
W6	Washer 6	16
W10	Washer 10	10
W12	Washer 12	10
W20	Washer 20	32
N6	Nut M6	2
N10	Nut M10	9
N12	Nut M12	5
N20	Nut M20	16
A6-4	Button Head Screw M6X10	12
H10-5	Hex Head Screw M10X25	1
SC6-12	Socket Head Cap Screw M6X45	2
SC10-10	Socket Head Cap Screw M10X50	1
SC10-18	Socket Head Cap Screw M10X90	4
SC10-20	Socket Head Cap Screw M10X100	2
SC10-21	Socket Head Cap Screw M10X105	1

PART NO.	DESCRIPTION	QTY
SC12-21	Socket Head Cap Screw M12X105	5
H20-22	Hex Head Cap Screw M20X110	16