

ASSEMBLY INSTRUCTIONS

CALIBER SERIES

BLK STAIR CLIMBER W/ LED DOT-MATRIX

SKU: CCB-STC-22.1

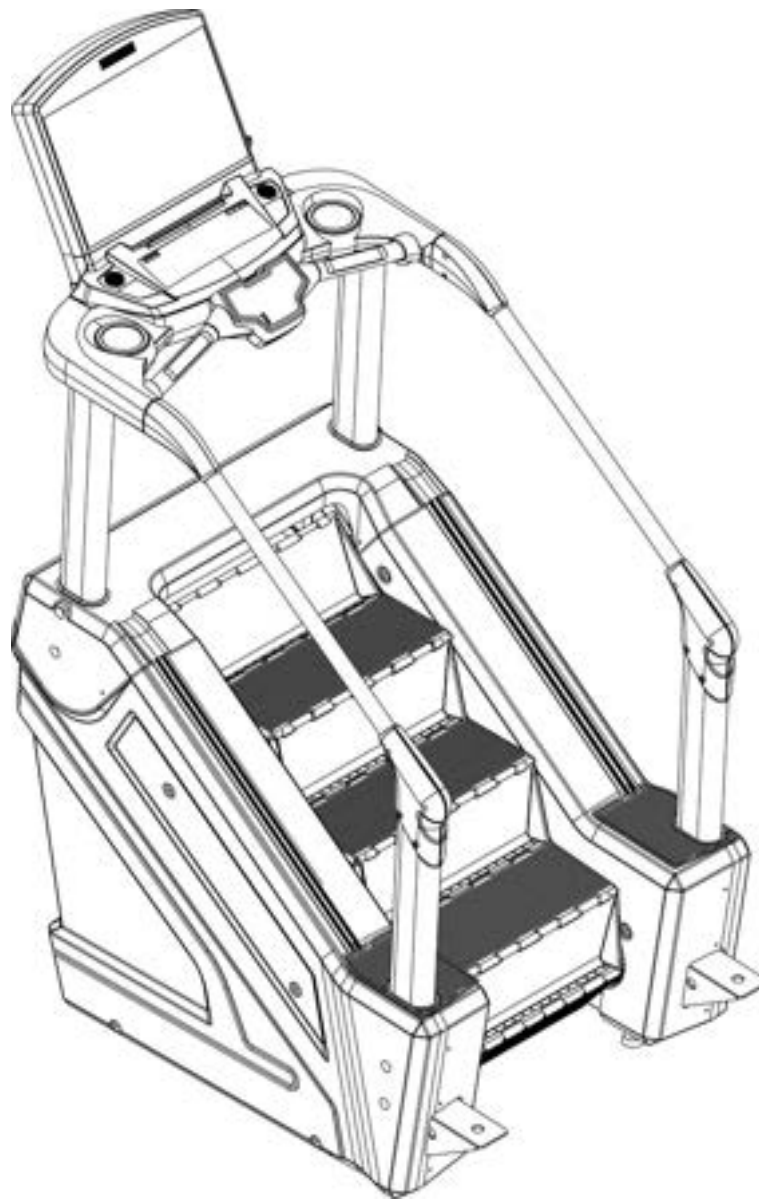

CAUTION: Read all precautions and instructions before using this equipment. Save this manual for future reference.

COMPOUND
FITNESS EQUIPMENT

Content

1. Overview drawing	2
2. Safety instruction	3
2.1. Input power requirement	6
2.2. Machine level adjustment.....	7
2.3. Power switch.....	7
2.4. Emergency stop system.....	8
3. Assembly Parts.....	9
4. Parts list.....	10
5. Assembly steps.....	11
6. Console operation instruction	20
6.1. Console introduction	20
7. Heart Rate Exercise.....	22
7.1. Heart Rate Exercise	22
7.2. Heart rate monitor system.....	23
8. Exercise Program	24
9. Trouble Shooting	34
10. Metric/ Imperial Unit Switch.....	35

1. Overview drawing

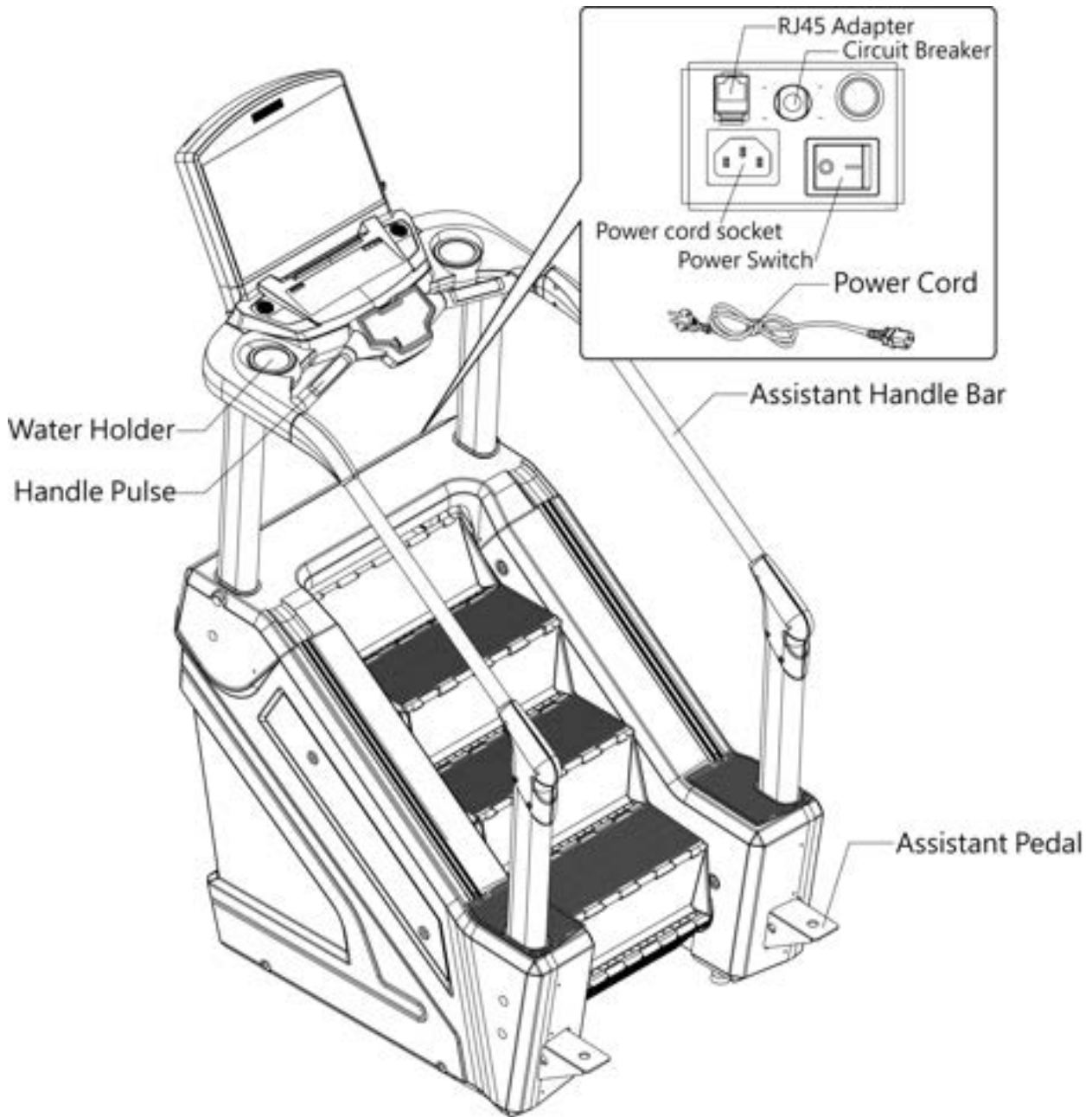

2. Safety instruction

When operating this product, please be aware and follow the operation and protection standards as below:

■ **DANGER** – To reduce the risk of electric shock :

Always unplug this product from the electrical outlet immediately after using and before cleaning.

■ **WARNING** – To reduce the risk of burns, fire, electric shock, or physical injury :

1. When this product is connected with power, please always be attention on the operation status to avoid any injury or dangerous.
When there the machine is not operating, we suggest to turn off the power and unplug the power cord.
2. Always be aware when children, pets, patients or disability people is using or get closing to this machine, to avoid any injury or dangerous.
3. Always follow the operation instruction in this user manual to use this machine.
Do not use any product or part which is not recommended by the official manufacture company to avoid the dangerous.
4. Never operate the product if it has a damaged cord or plug. If it is not working properly, damaged, or water dropped inside, please return the product to the service center of seller for examination and repair.
5. When moving the machine, do not use the power cord or the other cables as the rope.
6. Do not put the power cord on the high heat area or ground.
7. When the product cooling hole is stuck by dust or hair, please make the cleaning before operate the machine.
8. Do not install anything between the any gaps of this machine.
9. Do not use this machine at outdoor.
10. Do not use machine in a thin air or smoky room.

11. Before shut down this product, please turn off the power switch and then unplug the power cord.
12. Connect the product to a properly grounded socket only
13. If the power cord is damaged, please contact the seller or manufacturer to make the replacement to avoid accidents.
14. This product is not appropriate for people with physical disabilities, mental illness and inexperienced users (including children), unless there is a person who is responsible for their safety, be able to use the machine correctly and address the instruction properly. The incorrect or inordinate training will harm your body health
15. The incorrect or overload training will harm your body health
16. Please assemble the machine at the wide and flat space
17. Safety area would be 2000*1000 mm behind the machine
18. Maximum user weight is 180 KG
19. Please make the routine maintenance and safety check for the machine
20. Any exercise setting part is not allowed to take off from the machine
21. The correct operation method is like figure in below:



22. If the first stair is too high, please use the assistance pedal to get on the product.
23. When get on or get off this product, please always hold the assistant handle bar to

avoid any injury or dangerous.

24. When operating this product, please clip the safety clip on the cloth. User should stand on the second stair and hold the assistant handle bar as the standby position. Do not start the product before standing on the stair.
25. No matter get on or get off this product, please always hold the handle bar as the assistance.
26. Press STOP key to end the operation and wait the stair to be totally stop before get off the product.
27. The step area is 526*250 mm.
28. This product is for commercial use only.

2.1. Input power requirement

This product required 220 - 240 V power and the well grounded socket (see the figure in below). Please make sure the power socket is qualified before plug in the power cord.

Wirings should be transported according to the electric law of the local country. High pressure wires, low pressure wires and underground wires should be transported separately and can't connect with or twist other wires.

Improper connection of the grounding plug can result in the risk of electric shock. Check with a qualified electrician or serviceman if you are in doubt as to whether the products are properly grounded. Do not modify the plug provided with the product – If it will not fit the outlet, have a proper outlet installed by a qualified electrician.

Figure
Grounded power cord and socket

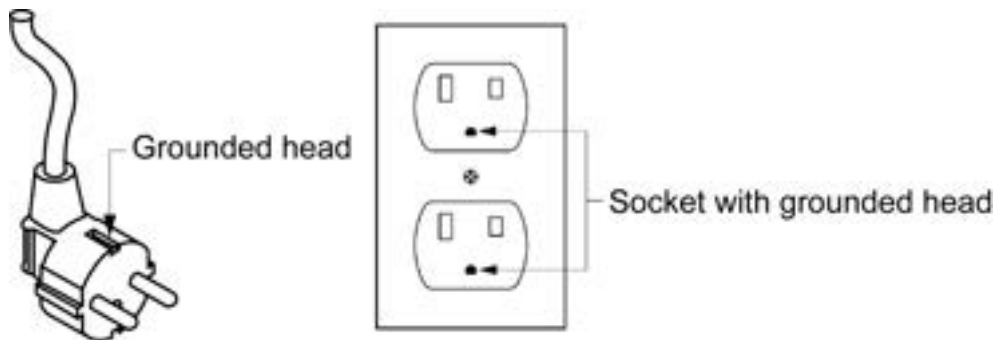

2.2. Machine level adjustment

If the floor ground is not flat or the support food is not fixed, it will lead the stair climber to be wobble during the operation and effect the slope of the stair.

How to adjust the machine level:

1. Loose the A nut with the counterclockwise direction.
2. Adjust foot pedal B to the suitable height.
3. Lock tight nut A with the clockwise direction.
4. The same adjustment method for all the foot pedals.

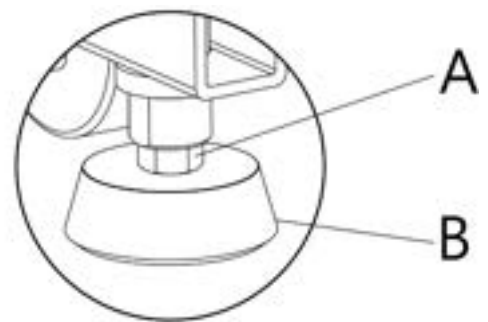

2.3. Power switch

The power switch location is on the bottom back side of the stair climber. I means ON, O means OFF.

2.4. Emergency stop system

The stair climber paired with the emergency stop system. The figure in below is the safety key set, and shows how to work the emergency stop on the stair climber:



Pull the rope.



The safety key will be pull out and stop pulling when you feel the key is stuck.



Insert the safety key back.



The stepmill will back to the standby mode.

3. Assembly Parts

A. Main frame set



B. Console set



C. Console back cover



D. Accessory tray back cover

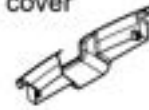

E. Accessory tray set

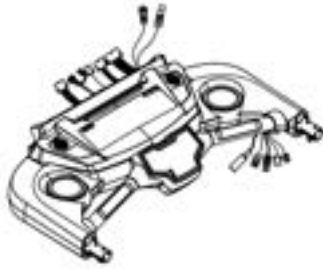

F. Assistance handle bar set



G. Front upright tube set



H. Rear upright tube set



I. Assistance handle bar cover



J. Rear upright tube cover



K. Assistant pedal



L. Water proof cover



N. Accessory tray lower cover



4. Parts list

	ITEM	Description	Qty
Step1	K03	Hexagon socket head steel screw M10xP1.5x70	4
	K04	Flat washer $\Phi 10 \times \Phi 20 \times 1.5t$	4
Step2	K03	Hexagon socket head steel screw M10xP1.5x70	4
	K04	Flat washer $\Phi 10 \times \Phi 20 \times 1.5t$	4
Step3	K15	Umbrella head steel screw M8XP1.25X15 with nylok blue	4
	K16	Flat washer $\Phi 8 \times \Phi 20 \times 1.5t$	4
Step4	K05	Hexagon socket head steel screw M8xP1.25x30	4
	K08	Hexagon socket head steel screw M8XP1.25X45	4
	K09	Camber washer $\Phi 8.5 \times \Phi 16 \times 1.0t-R19$	4
Step5	K10	Umbrella head steel screw M8XP1.25X20	2
	K11	Console fix washerNT-3409	2
	K12	Spring washer M8	2
	K13	Umbrella head cross self tapping screw $\Phi 4 \times 16$	2
	K14	Umbrella head cross screw (thread cutting) M4XP0.7X15	2
	K20	Umbrella head cross self tapping screw $\Phi 4 \times 20$	3
Step6	K06	Umbrella head cross self tapping screw (stainless) $\Phi 4 \times 16$	10
	K07	Umbrella cross screw (stainless) black M4xP0.7x15	8
Step7	K01	Hexagon socket head steel screw M10xP1.5x25	4
	K02	Flat washer $\Phi 10 \times \Phi 30 \times 1.5t$	4
	K21	Buckle end cap	8
Step8	K22	CABLE Adapter	
Tools	K17	L shape allen wrench + Cross driver 5x70x70mm	1
	K18	L shape allen wrench 6x40x120mm	1
	K19	L shape allen wrench 8x55x110mm	1

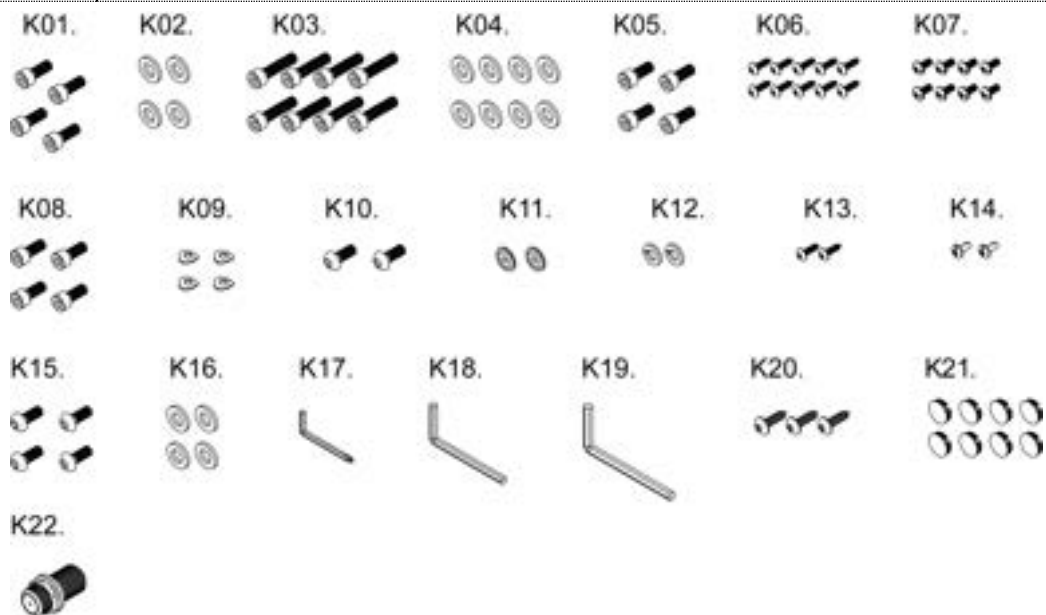

5. Assembly steps

■ STEP1 Assemble main frame and front upright tube set

Install water proof cover (L) into front upright tube set (G) first, *Then pull the main cable out of the upright opening on the right side of the Main frame (A) and pull the cable up through the right side Upright tube (G).* assemble main frame set (A) and front upright tube set (G) with screw (K03) and flat (K04). No need to lock tight the screws yet.

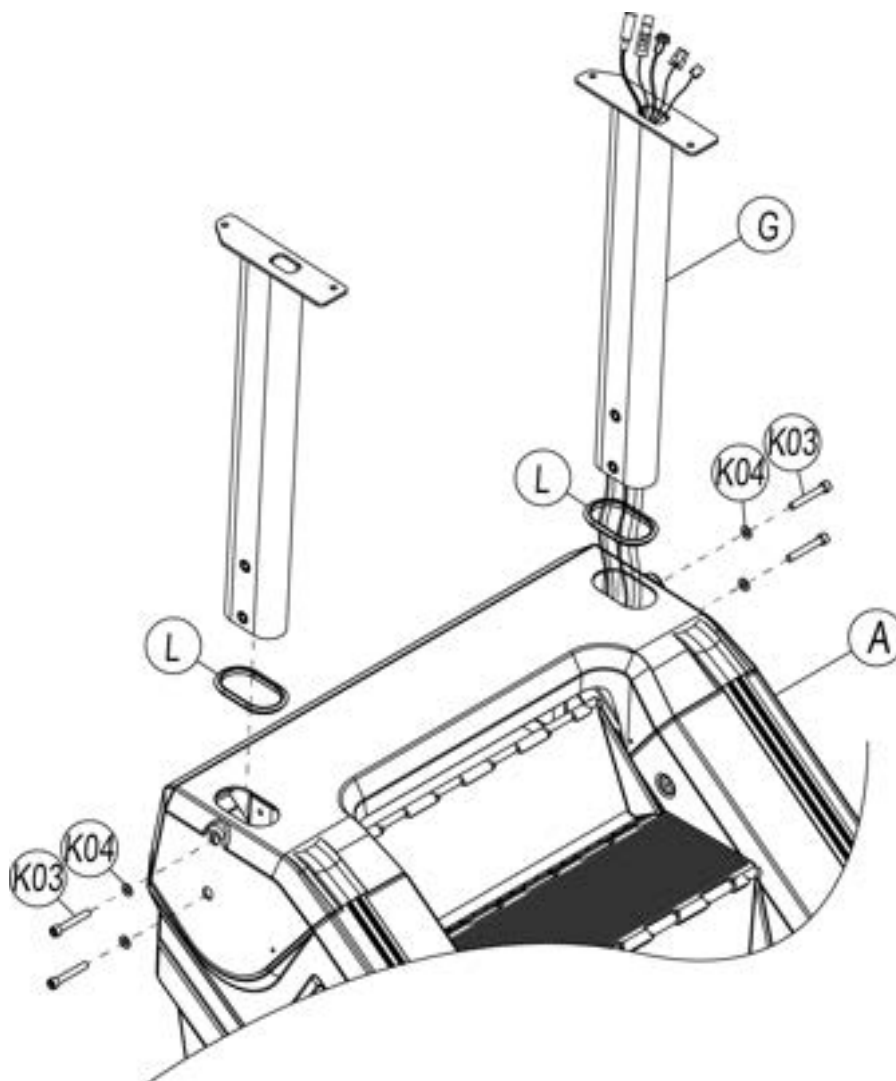

■ **STEP2 Assemble main frame and rear upright tube set**

Assemble main frame set (A) and rear upright tube set (H) with screw (K03) and flat (K04). No need to lock tight the screws yet.

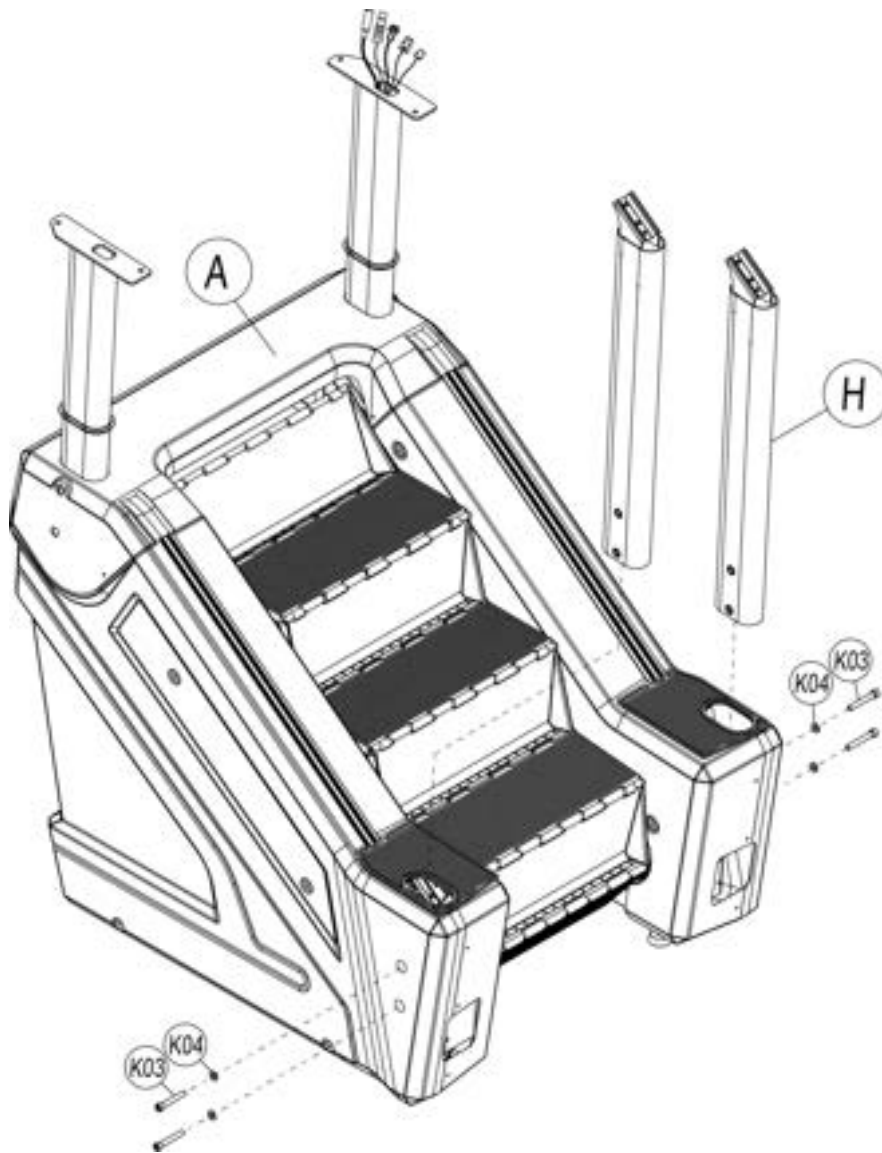

■ STEP3 Assemble accessory tray and front upright tube set

Connect the wires of the front tubes set (G) with the wires of the stuff shelf (E). After that, lock the stuff shelf set (E) with the front tube set (G) with screw (K15) and flat washer (K15), please do not drive tight at that moment. And make sure the wires are not pressed.

Notice:

1. When connecting the control wires, it will show the “Click” sound after well connect.
2. To avoid any dangerous, ALWAYS have two or more people to make the assembly together.

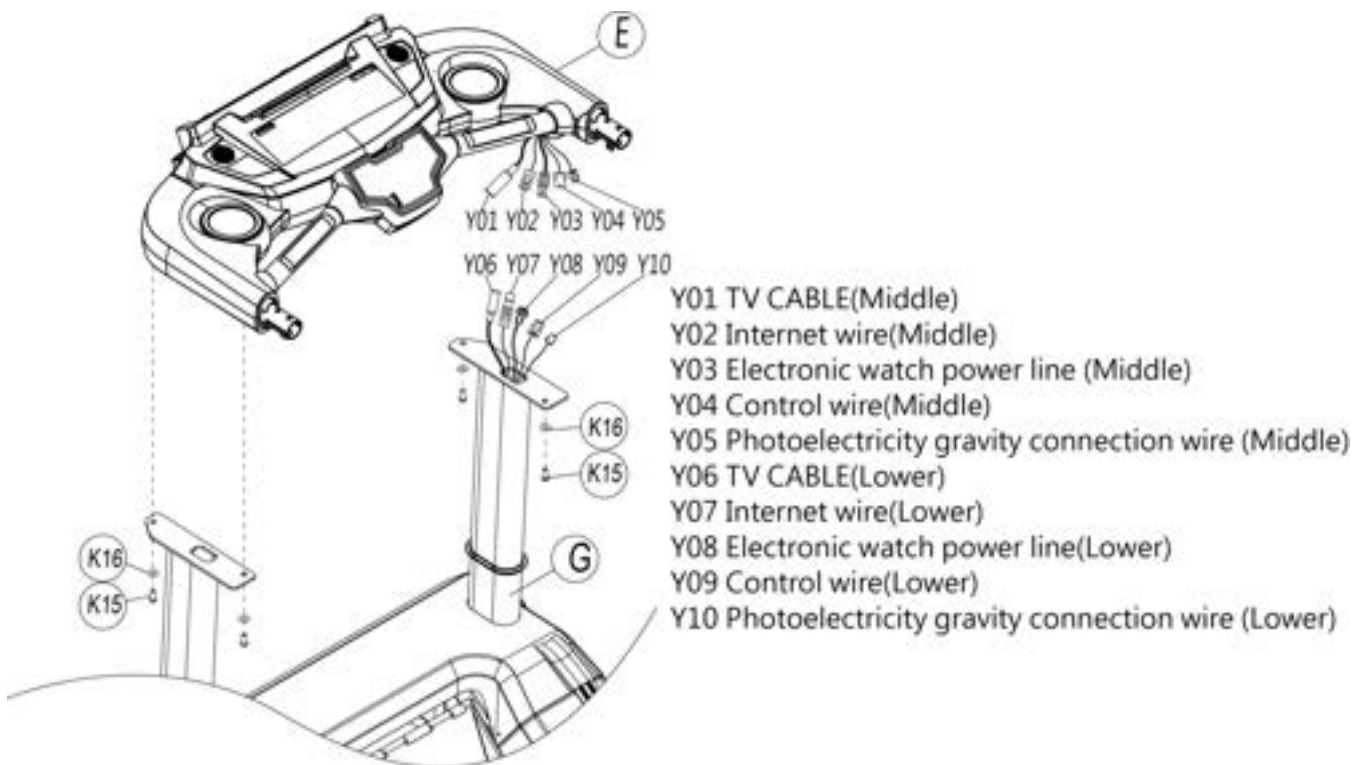

■ STEP4 Assemble accessory tray and assistant handle bar set

See as the figure in below to assemble the assistant handle bar (F) into the accessory tray set (E) with screw (K08) and camber washer (K09), but no need to lock tight yet. Use screw (K05) to fix the assistant handle bar on the rear upright tube set (please notice the assistant handle bar has the left/right side difference). Bolt the screws for some rounds and check if screws did not get stripped or not. Then, bolt and lock tight for all the screws.

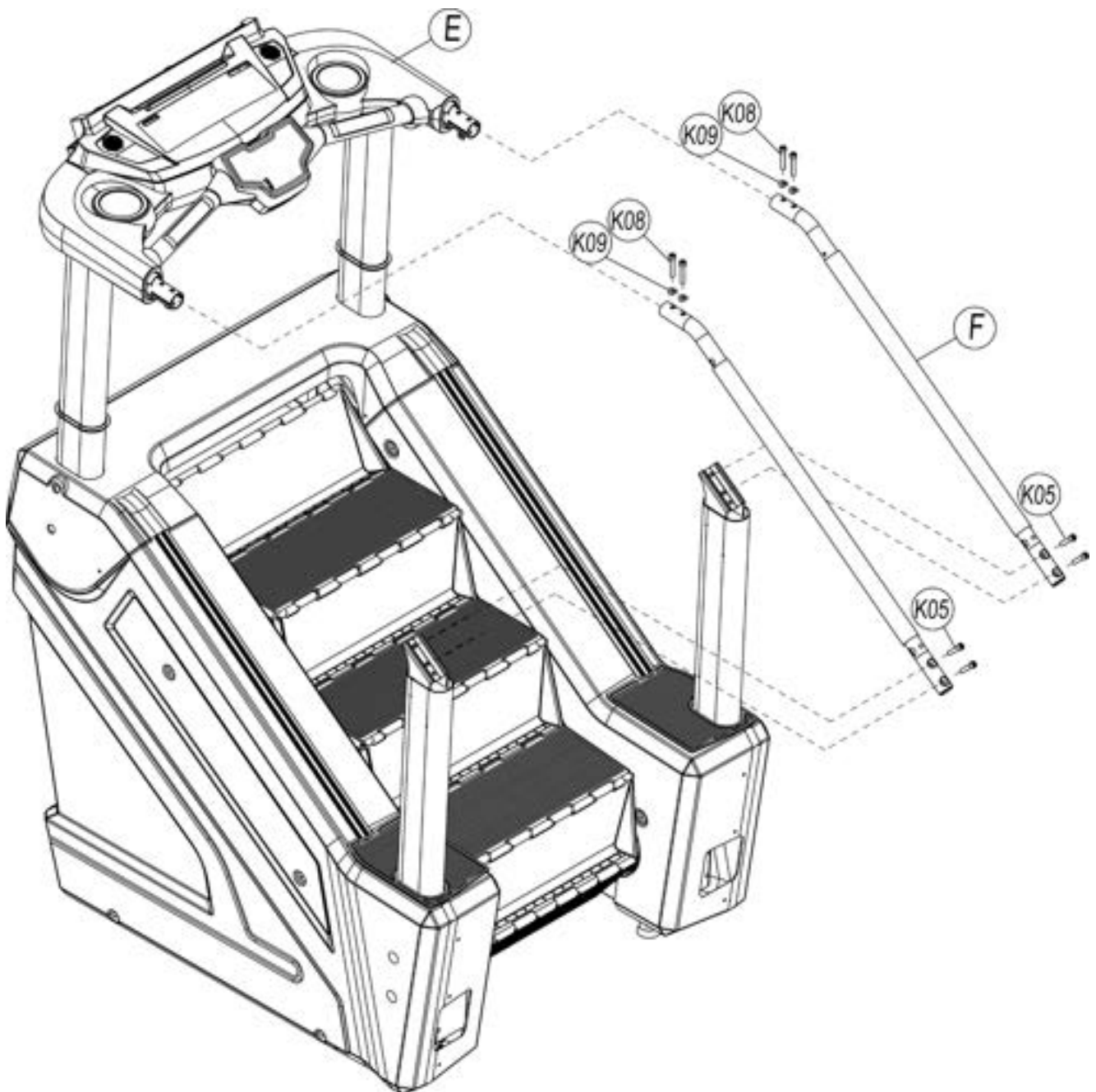

■ STEP5 Assemble the main frame and the console set

Assemble console set (B) on the accessory tray set (E) and connect the control wires on accessory tray (E) to console wires. When connecting the wires, will need one person to hold the consoles set and be careful not to drop down on the console set. Use screw (K10) and washer (K11 & K12) to bolt the console set on the accessory tray set (E). Use screw (K13) to bolt the console back cover (C) on the console. Then, use screw (K14) to bolt the accessory tray back cover (D) on the accessory tray, please be careful not to clip the wires when bolt the covers. After complete the assembly, see the figure in below and use screw (K20) bolt the accessory tray lower cover (N) on the accessory tray set.

Attention :

Wire is united in union must really clamp tight, avoid loose fall while using

TV Cable (Middle section) is prepared for the TV system

In case of danger, the machine assembly must be jointly carried out by two or more people and do not assemble alone.

The network cable (Middle section) is prepared for the network system

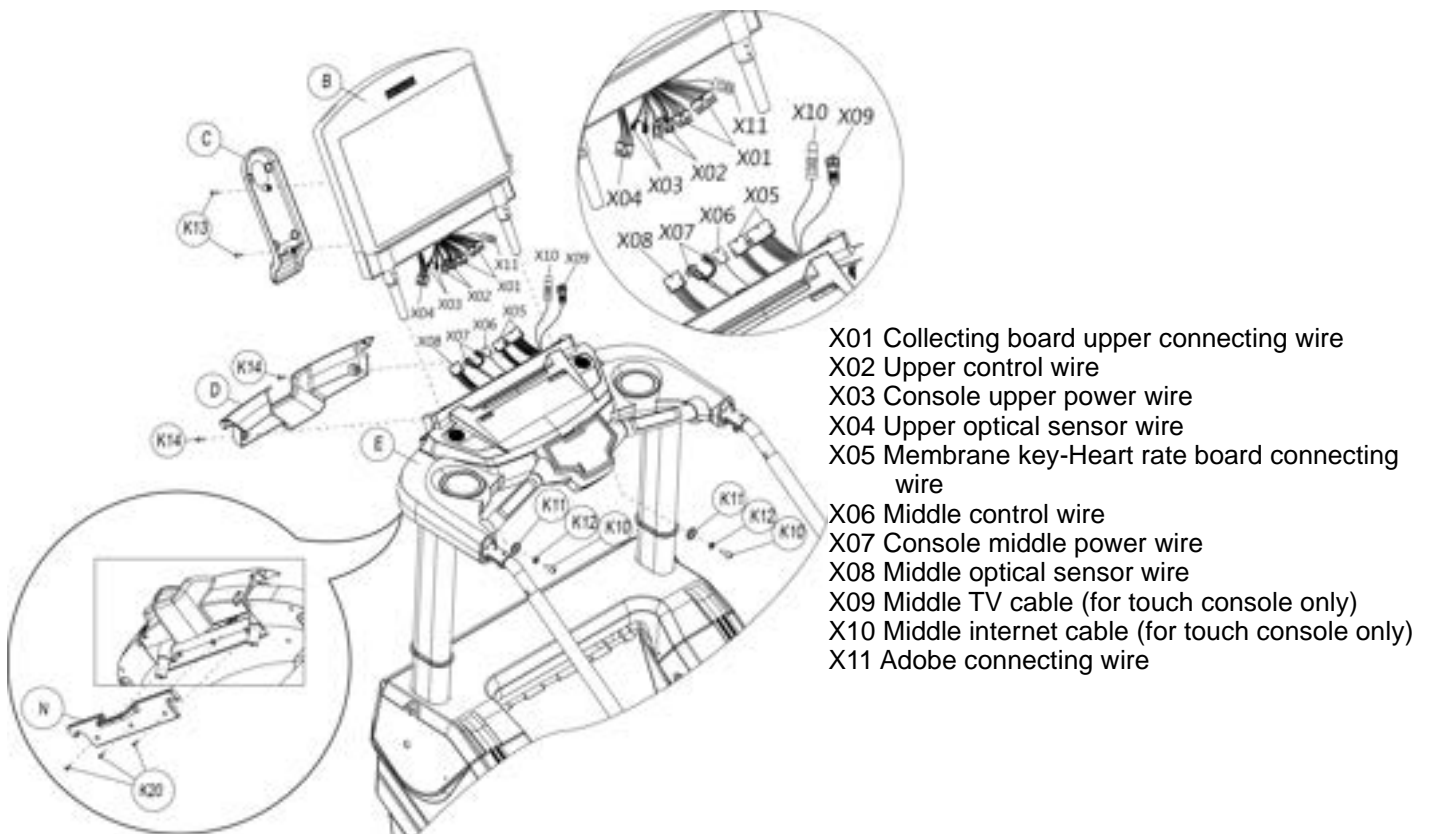

■ STEP6 Assistant handle bar assembly

See the figure in below, use screw (K06) to bolt the assistant handle bar cover set (I) on the assistant handle bar. Use screw (K06 & K07) to bolt the upright tube cover set (J) on the assistant handle bar. Then, press the water proof cover into the main frame set.

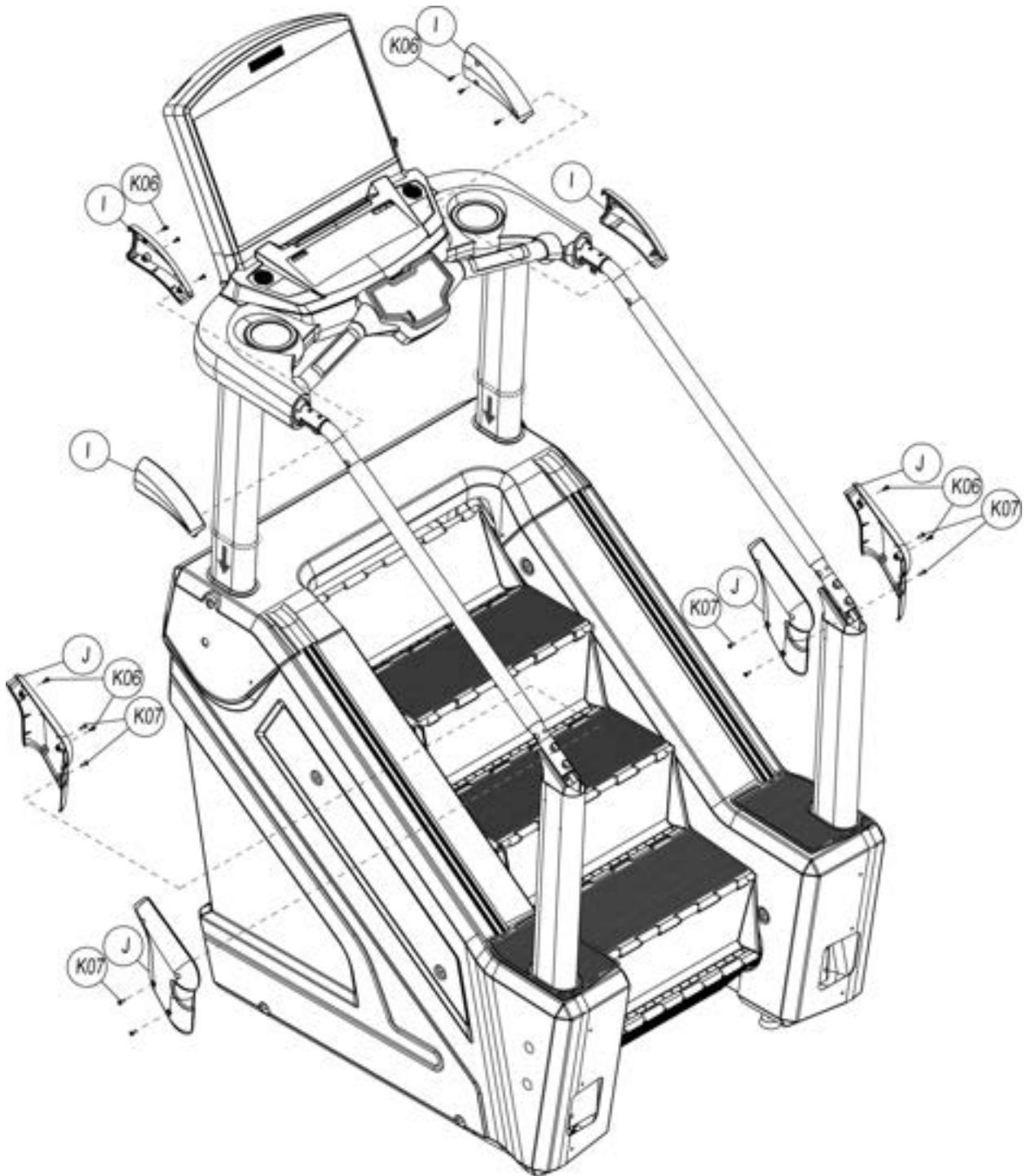

■ STEP7 Assistant pedal assembly

Use screw (K01) and flat washer (K02) to bolt the assistant pedal (K) on the main frame.
Finally, install the buckle end cap (K21) into the main frame orderly.

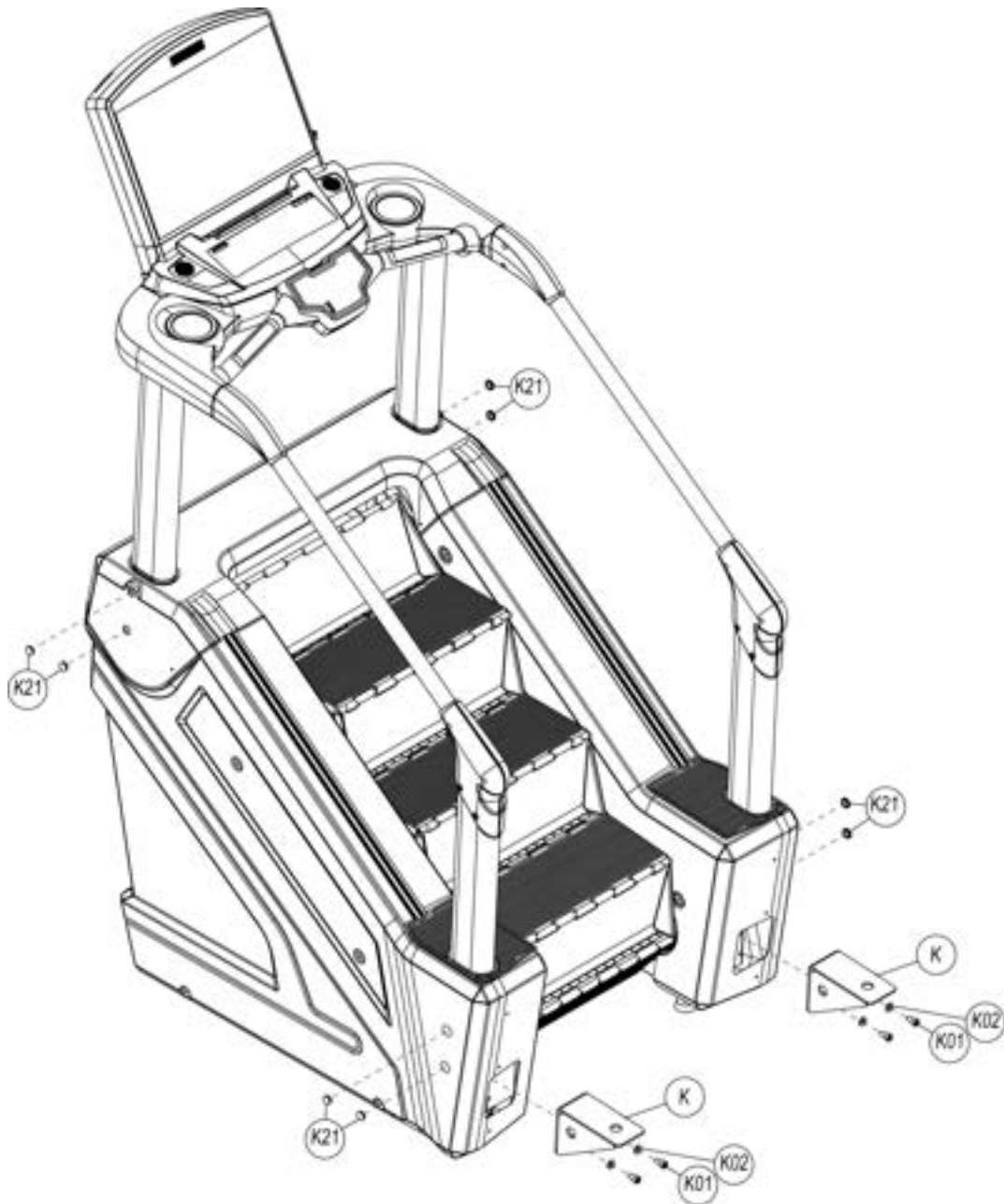

■ STEP8 Cable connector assembly

Attention: cable transferring connector(n) is ready for TV cable systems using

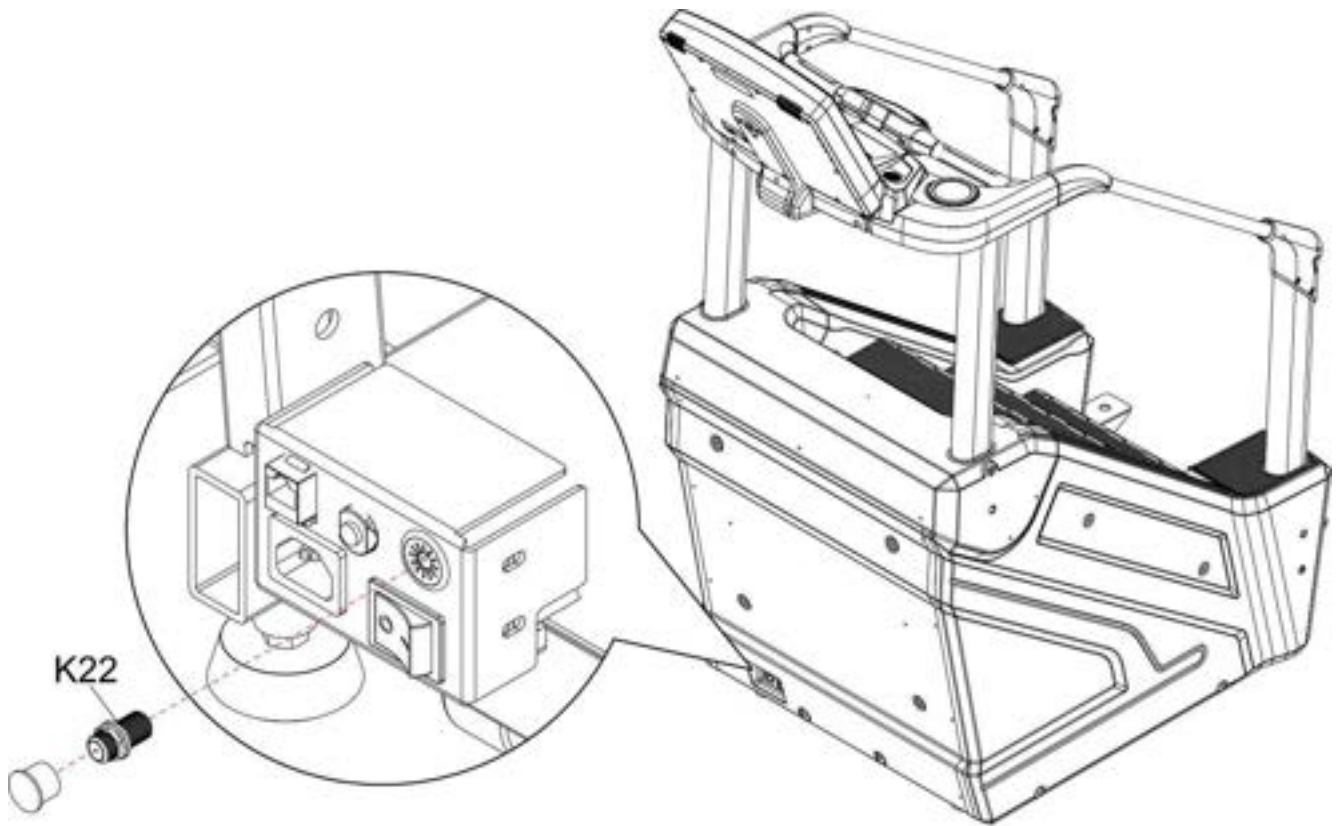

■ **STEP9 Settle down the stair climber**

After confirm the settle down position, turn the foot pedal until the moving wheels are higher than the foot pedal.

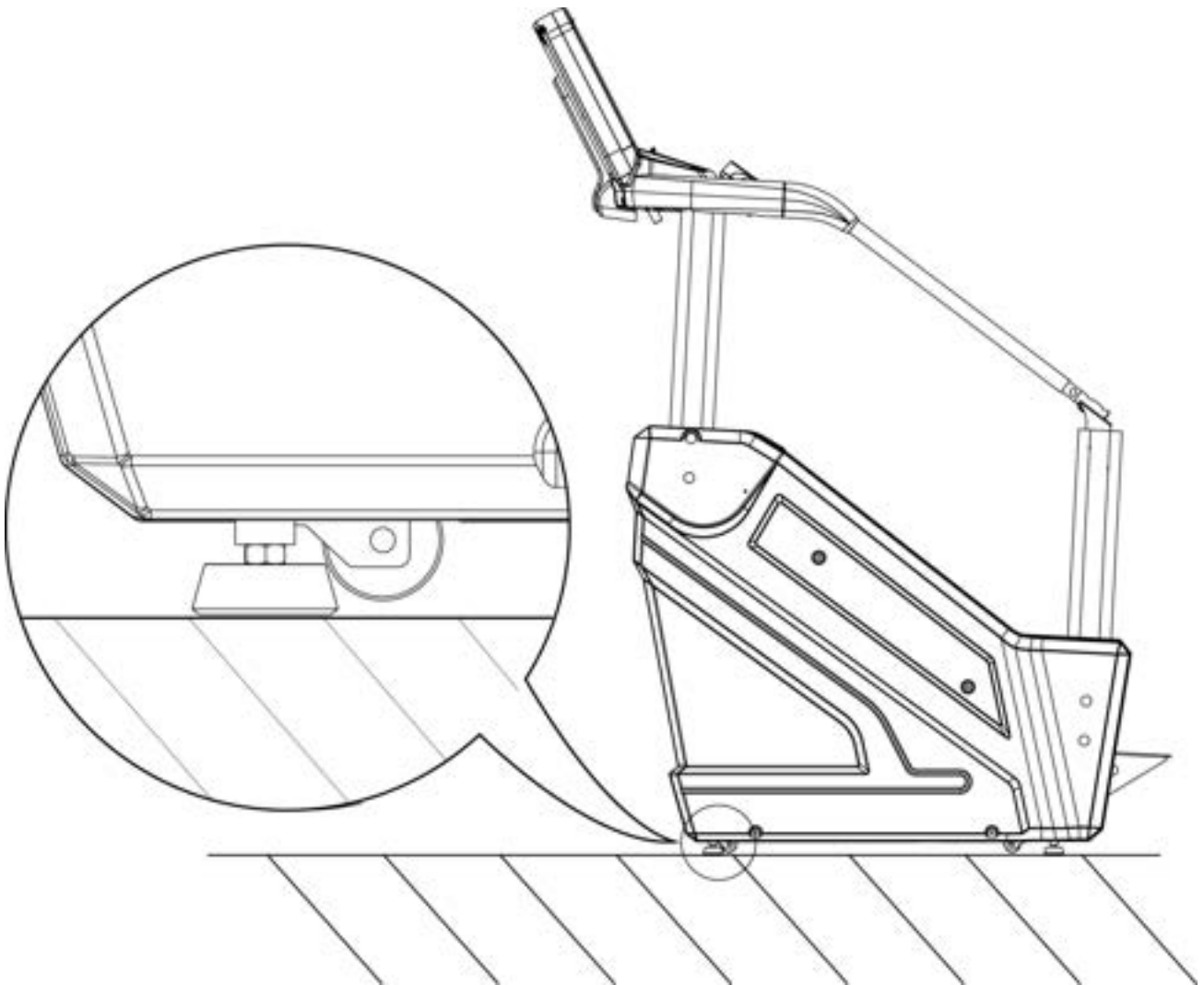

6. Console operation instruction

This stair climber paired an easy operate console for the all-age-user. User could enter the personal data into the console for setting the different exercise goals.

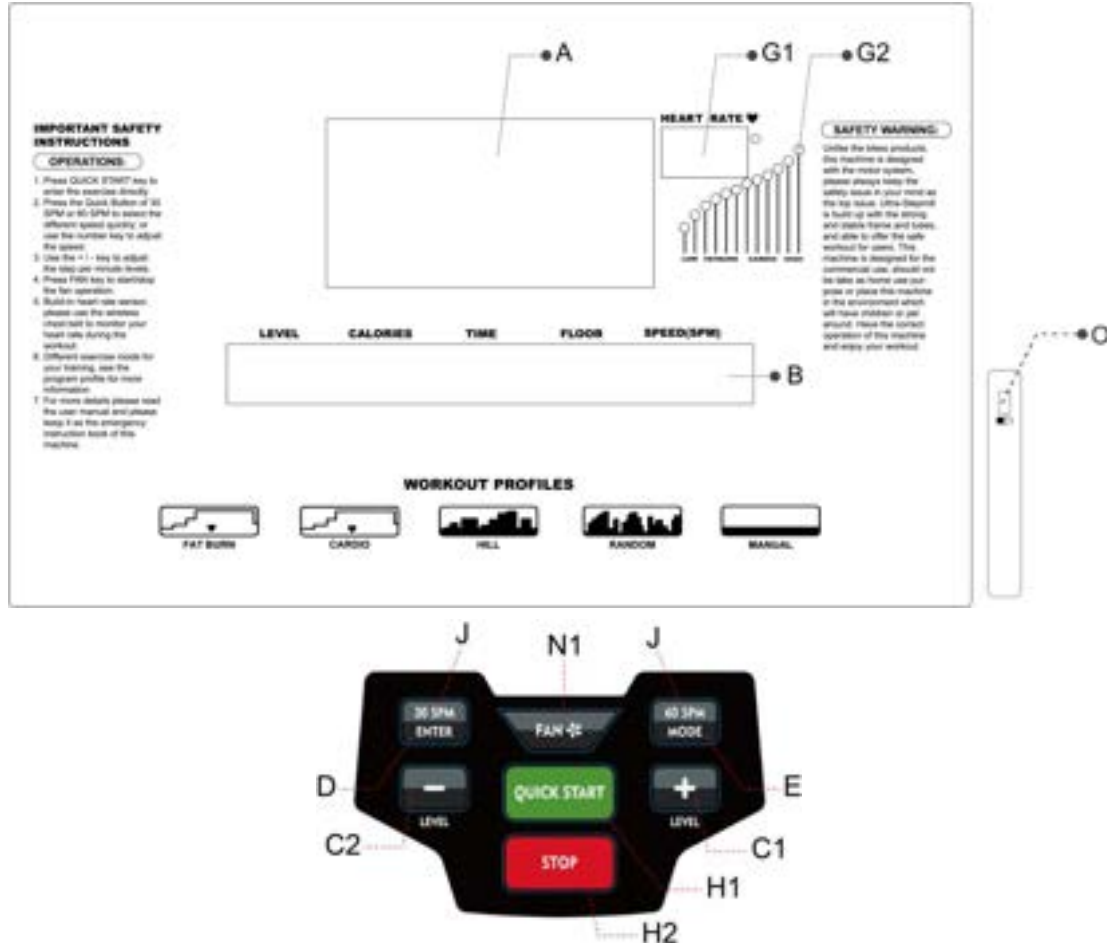

6.1. Console introduction

A	WORKOUT	Display the LEVEL changing difference during the exercise.
	PROFILE WINDOW	The height of the LED bar indicates to the LEVEL percentage.
B	MESSAGE CENTER	Display the operation steps for each program and all the control and program instruction information, such as Calories, Distance, Time, Level and SPM value.
C1	INCREASE LEVEL	Press this key to increase the level during exercise, maximum to level 20.
C2	DECREASE LEVEL	Press this key to decrease the level during exercise, minimum

		to level 1.
D	ENTER	Press this key confirm the program data or value, such as: Exercise Time, Speed, Weight, Distance, Exercise Goal, Gender or Target heart rate. After set the data, press ENTER to confirm the setting.
E	MODE SELECT KEY	Under the standby mode, press MODE to select different program, including GOAL, HRC, TRAINING, and PROGRAM.
G1	HEART RATE DISPLAY	Display the user heart rate when hold the handle pulse sensor or wear the chest belt.
G2	HEART RATE RANGE INSTRUCTION	After enter the user age and calculate with the formula, it will display the user heart rate range. This value can only display after enter the user age when program start.
H1	QUICK START	Press this key to start the exercise directly, no need to select the programs. During the exercise, use LEVEL “+” and “-“ key to adjust the speed.
H2	STOP	Press 1 time to be pause; under the pause status, press again to end the exercise and back to the standby mode.
J	SPM QUICK KEY	SPM quick keys have 2 options, 30 or 60 SPM. During the exercise, press the SPM quick key would change the speed and display in the SPM chart.
N1	FAN START/STOP KEY	Control the fan to start or stop.
O	USB CHARGE	The USB hole could offer the power charge for iOS device or Android device with output power 5V/1A.

7. Heart Rate Exercise

According to the report, maintain a stable heart rate during exercise is the best method for detecting exercise intense and achieve the target. This stair climber can meet this requirement.

7.1. Heart Rate Exercise

Set the target heart rate range and conduct aerobics to improve cardiovascular Function.

On the right is the picture shows age and its corresponding heart beat times.

Heart rate exercise includes three modes:

- Hill Heart Rate
- Interval Heart Rate
- Intensive Heart Rate

Heart rate interval

Every function has its own advantage. Please refer to chapter 7 for details.

Note: Please first consult fitness instructor before exercise for suitable exercise

	<u>AGE</u>	<u>65%</u>	<u>80%</u>
	10	136	168
	20	130	160
High Intense : Interval Exercise	30	123	152
Lower Intense : Fat burned	40	117	144
	50	110	136
	60	104	128
SUGGESTED TARGET HEART RATE AS % OF MAX ACSM HEART RATE RANGE: 55% - 90%	70	97	120
	80	91	112
	90	84	104
	100	78	96

7.2. Heart rate monitor system

■ A. Hand pulse sensor

Put hands on the steel sensor of the front handrail to detect the pulse system during workout. Each handrail is equipped with two sensors. You must grip these four sensors during workout, then the stair climber control board could catch the pulse signal. After 20 to 30 seconds, the result will display.

When the stair climber speed is over than 60 SPM, it is suggest to use the chest belt heart rate sensor instead of the hand pulse sensor.

■ B. Chest belt heart rate sensor

Heart rate monitor system includes chest belt heart rate sensor which should be make electrode detect on human body. Use the wireless technology to transmit the heart rate signals to the control board. Chest belt is not the necessary attachment. You can purchase if you need

Figure: Electrode position and wearing method of chest belt



The figure shown above demonstrates the positions of central electrodes of the chest belt and the instruction for use. Electrodes are located at the grooves on both sides of the center of the inner side of the belt. The electrodes must be kept moist when in use to transmit the heart beat signals to the receiver more accurately. Keep the chest belt under the pectoral muscle when in use and adjust the chest belt to a snug fit for smooth breathing. The direct contact of electrodes and skin provides the best efficiency of heart rate

monitoring, however, wearing a thin, damp shirt can reach the same results as well. If moistening the electrodes is needed, please pull out the chest belt from the center and moisten the electrodes directly.

※ **The chest belt heart rate monitor is the optional device.**

8. Exercise Program

Exercise Program Summary

The following programs are preset in factory :

■ QUICK STSRT

When the stair climber is power on, press QUICK START key to start exercise directly. To make calories consumption exact, set the correct weight of the user and the suitable level, User LEVEL up/down key to adjust the speed.

■ GOAL

- Time Goal

Set the target time for the exercise, when the target time is achieved, the program will end automatically.

Setting Range: Time Preset: 20 minutes / Setting Range: 10-95 / Unit: Minutes

- Distance Goal

This program is designed to test the endurance of the user. When user completes the target floor numbers within limited time and reaches the goal, the program will end automatically.

Setting Range: Floor Preset: 20 Floor / Setting Range 1-99

- Calories Goal

This program is designed to help the weight control and fat burn. When user completes the target burned calories within limited time and reaches the goal, the program will end automatically.

Setting Range: Calories Preset: 200 cal / Setting Range 40 - 600 / Unit: Cal

HRC

- Hill Heart Rate Control

The preset heart rate goal is 80% of the maximum heart rate. The target heart rate will be obtained based on user's personal setting data. The column height represents the percentage of the maximum heart rate. There are totally seven heart rate goals in the program, among which, there are three varied goals, respectively being 70%, 75% and 80%. The rest goals maintain 65% as the minimum limit. (See the following figure). After three minutes' standard warm-up exercises, the heart rate will increase until 70%. Keep this rate in the running for one minute and then decrease the speed level to lower down the heart rate to 65% per minute. Each heart rate shall keep for 1 minute. The varied setting will operate in term during the program operation. When run to the end of the exercise, program will enter into the cooling mode. During the operation period, if the heart rate is out of the maximum rate for 45 seconds, the stair climber will enter into the pause mode. And when heart rate does not reach to the goal rate or changing between the two goal rates, then the system will increase or decrease the speed. If the first heart rate goal is not able to reached, the program will enter to next goal. During the exercise, please be sure the chest belt had wearing on correctly or hold the hand pulse sensor tightly, otherwise the program could not operate smoothly.

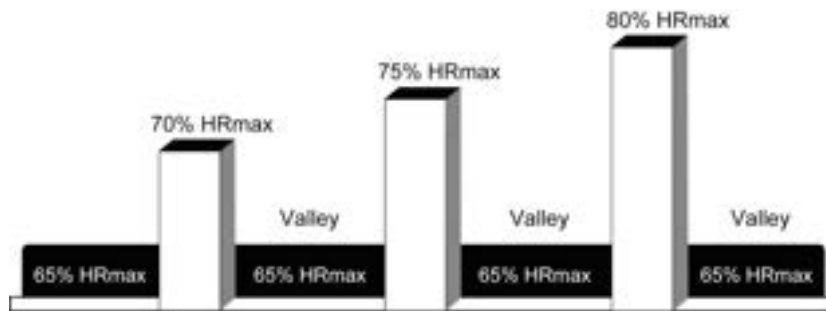

Heart rate control display image

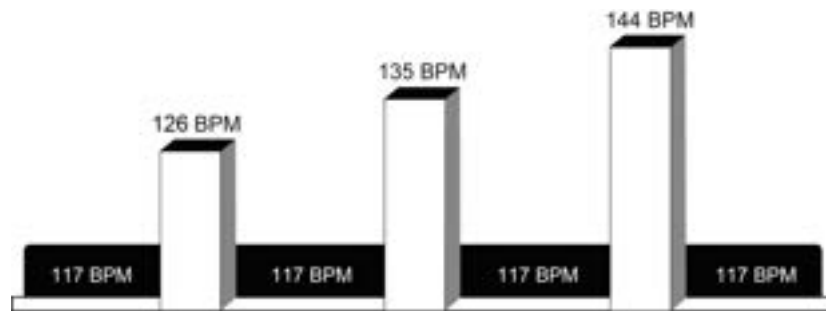

Corresponding targeted heart beat times

Take a 40-year old user for instance, the heart beat goal is 80% of the maximum heart beat times: $(220 - 40) \times 80\% = 144$

- Interval Heart Rate Control

The interval heart rate control is similar to the heart rate control program, and the differences are:

First, the heart rate goals are 80% of the maximum heart rate. Target heart rate will be obtained based on user's information provided.

Second, the maintaining time of each heart rate goal is 3 minutes.

During the exercise, please be sure the chest belt had wearing on correctly or hold the hand pulse sensor tightly, otherwise the program could not operate smoothly.



Heart rate control display image

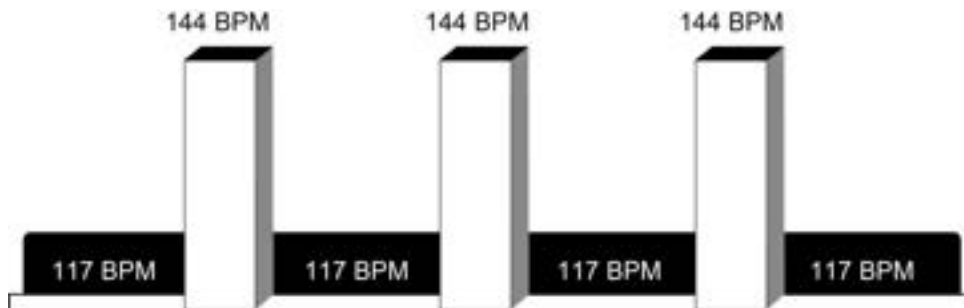

Corresponding targeted heart beat times

Take a 40-year old user for instance, the heart beat goal is 80% of the maximum heart beat times: $(220-40) \times 80\% = 144$

- Intensive Heart Rate

Intensive heart rate program (Suitable to the experienced users who will break the general health level and challenge the limit). In the running process, the heart rate changes rapidly between two heart rate goals (65%-85%), similar to the changes in short-distance racing. During the exercise, please be sure the chest belt had wearing on correctly or hold the hand pulse sensor tightly, otherwise the program could not operate smoothly.

Note: User should wear the chest belt heart rate sensor.

- ※ Set the program to determine the heart rate goal and choose the high speed and low speed. After three minutes' preparation (warm-up exercise), the stair climber system will increase the speed to the low speed as preset to lead the heart rate of the user reach 85% of maximum heart rate (This will be the maximum target heart rate). After keeping steady for a period of time, the system will decrease the speed level to lead the heart rate of the user to 65% of maximum heart rate (This will be the minimum target heart

rate). After keeping steady for a period of time, the system will increase the speed level again. The program will operate the varied in term until the program end. If the first heart rate goal is not able to reached, the program will enter to next goal.

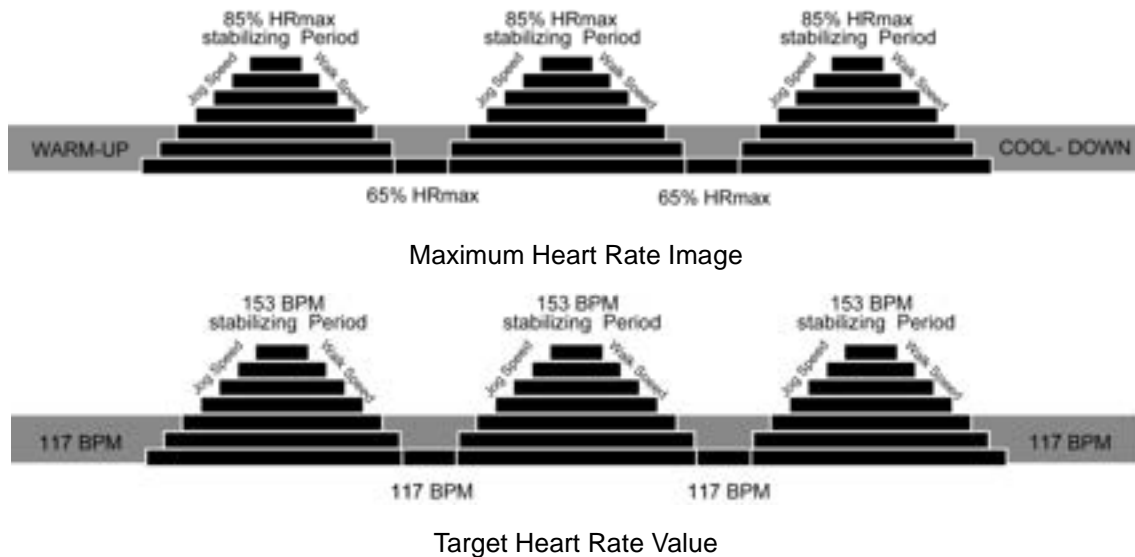

Take a 40-year old user for instance, the heart beat goal is 85% of the maximum heart beat times: $(220 - 40) \times 85\% = 153$

■ **PROGRAM**

- MANUAL

Manual is a continuous exercise program and user can set the speed at will during workout. Pulse panel will display heart rate calculated by user's age.

- RANDOM

The interval training program that system continuously changing the speed level and creating varied effect diagram.

- HILL

The interval exercise effect analysis diagram is the interval exercise program controlled by the console system, which could improve the cardio-pulmonary function with the scientific method. The whole program is divided into four stages, each stage represents different exercise intensity and the program window displays the operation status.

The heart rate test shall firstly choose the transitional stages for two areas to check the heart rate changes in the transitional stages. The two triangles in the picture is the heart rate check point. This program is the exercise program to combine the cardio-pulmonary function training, fat burning and regional heart rate training and is not the program to test the heart rate. Therefore, there is no prompt displayed to test the heart rate. During the exercise period, user shall wear the chest belt sensor or hold the heart rate sensor on the handler.

Warm-up	Gradually increase the exercise intensity by changing the speed level to make the heart rate reach the minimum heart rate goal, intensify the breathing and promote the blood circulation.
Plateau	Increase the exercise intensity slowly and maintain to make the heart rate reach the minimum heart rate goal and then check the actual heart rate.
Interval Training	Regularly increase the exercise intensity and then recover the heart rate. Make the rate reach the maximum heart rate goal and check the actual heart rate for the second time.
Cool-Down	The relaxation stage after exercise. Lactic acid is generated from the muscle in the oxidization process and the time and intensity of the cooling time rely on the execution time, speed, level and heart rate of the program.

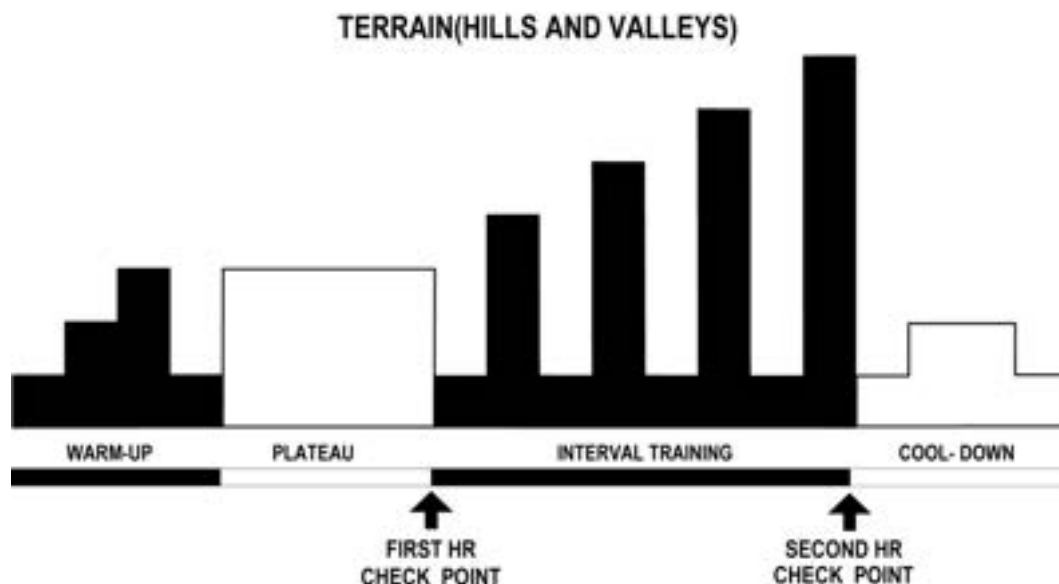

Each light column represents an interval and the whole program is composed by 20 intervals. The operation period of the program determines the program every 95 minutes. The default time setting is 10 minutes with the range from 10 to 95 and the unit is 5 minutes.

10-19 Minutes	The total time of the program is 10 minutes, the interval time is set to be 30 seconds. If the program time is 15 minutes, the interval time is set to be 45 seconds.
20-95 Minutes	The default continued time is 60 seconds for every default interval. If user want to extend the time of every interval, more than 60seconds. Every interval's time is equal to the fitness time user set divided with 20 sections, for example, if the set time is 80 minutes, every interval's time is 4 minutes.

- **SPEED INTERVAL**

When make the PROGRAM setting, you can preset the low and quick speed (Once confirmed the setting, the speed will not allowed to change during exercise). After the program start, use the Level “+” and “-“ key to change the exercise speed as the preset low and quick speed. Press the continuously flashing PROGRAM key on the electronic meter to shift the default jogging and running speed (once set, the value will not be changed at will). Press SPEED ARROW key to adjust other speed. The press to shift the PROGRAM key

from current jogging to running speed will adjust the speed to the default value.

- FAT BURN

The low intensity exercise program is mainly featured by burning the fat and makes the heart rate of the user to keep at 65% HR max (the target heart rate). In this process, it's necessary to wear the chest belt heart rate sensor or grasp the heart rate sensor on the handle bar. If the sensor is not detect well, the program window will display a heart shape to tell the heart rate value now is from the hand pulse heart rate sensor. The console system will control and display the heart rate, and adjust the speed automatically to maintain the target heart rate. This program is for warm up or low intensity exercise purpose, it is and will not accept severe exercises.

- CARDIO

The best training methods refer to the oxygenation exercises or the training to increase the angiocarpus functions.

While doing exercise, it's necessary to wear the chest belt sensor or grasp the hand pulse heart rate sensor on the handle bar, and then the program will automatically adjust the speed level and keep the heart rate goal according to the actual rate.

Note: The heart beat times goal for FAT BURN training program is calculated on the basis of the 65% HRmax and the CARDIO and HEART RATE HILL is calculated on the basis of the 80% HRmax

The above programs all require the determination of the weight of the user. When the stair climber enters this PROGRAM, use Level "+" and "-" key to set the weight value.

- TRAINING

FITNESS TRAINING 20

FITNESS TRAINING 40

This stair climber has the 20 Floors and 40 Floors self-challenge program. By setting the different level, the program would create a complied exercise diagram. The level represents to the difficulty of the exercise. The program will end automatically after reach the setting value.

- Stair climber Program Operation Diagram

When setting the HILL, RANDOM, FITNESS TRAINING 20 and FITNESS TRAINING 40 program, there will have 10 levels. When using QUICK START, there will be 20 levels. See the chart in below:

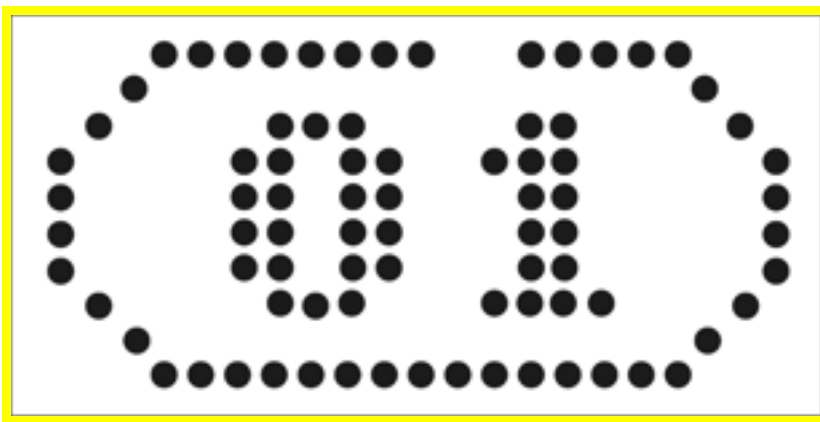

※ 1 loop means 1 floor

The console will use the led column to represent the level, use the speed “+” and “-“ key to change the level.

Intensity-Speed Reference			
LEVEL	SPM	LEVEL	SPM
1	20	11	90
2	27	12	97
3	34	13	103
4	41	14	109
5	48	15	115
6	55	16	121
7	62	17	127
8	69	18	132
9	76	19	137
10	83	20	140

9. Trouble Shooting

Error code	Possible reason	Solution	Note
Console No Power	1. Power Switch has been turned off	Turn on the power switch	
	2. Power switch light does not light up	Use the electric meter to check if the power socket has output the power.	Check if the voltage is 110/220V
	3. Inverter did not output DC 12V power	Replace inverter	
	4. Control wire defect	Replace control wire	
	5. Console main board defect	Replace console main board	
E01	Inverter input power with low voltage	Replace filter or chock or inverter in turn	Check if the voltage is 110/220V
E02	Inverter heat sensor abnormal	Replace inverter	
E04	Inverter output current overloading	Add lubrication oil or replace inverter	
E06	Inverter voltage overloading	Replace inverter breaker	
E08	Inverter grounding abnormal	Replace inverter	
E09	Inverter overheat	Add lubrication oil, clean inverter dust or replace inverter	
E10	Inverter sense motor overloading	Replace motor or inverter	
E11	Inverter overloading	Add lubrication oil or replace inverter	
E12	Inverter system overload error	Replace Inverter	
E13	Inverter sense motor cable disconnect	Replace motor or inverter	
E14	Inverter breaker defect	Replace inverter breaker	
E33	Inverter flash defect	Replace Inverter	
E34	Inverter flash defect	Replace Inverter	
E35	Inverter low voltage warning	Replace filter or chock or inverter in turn	Check if the voltage is 110/220V
E37	Inverter emergency stop	Replace inverter or control wires or console main board	
E41	Inverter high heat warning	Add lubrication oil, clean inverter dust or replace inverter	
E77	Inverter communication error	Replace inverter or control wires or console main board	
E78	Console membrane key error	Replace membrane key or membrane key transport board or console main board	
E79	Light sensor (A120) error	Replace or adjust light sensor or console	

10. Metric/ Imperial Unit Switch

1. At the standby page



2. Press STOP + ENTER key for around 10 seconds to enter the engineer mode page



3. Press ENTER key 2 seconds to enter the unit switch page



4. Use SPEED “+” and “-“ key to switch the Metric/ Imperial unit



5. Press ENTER key for 4 times to get back to standby page and save the setting

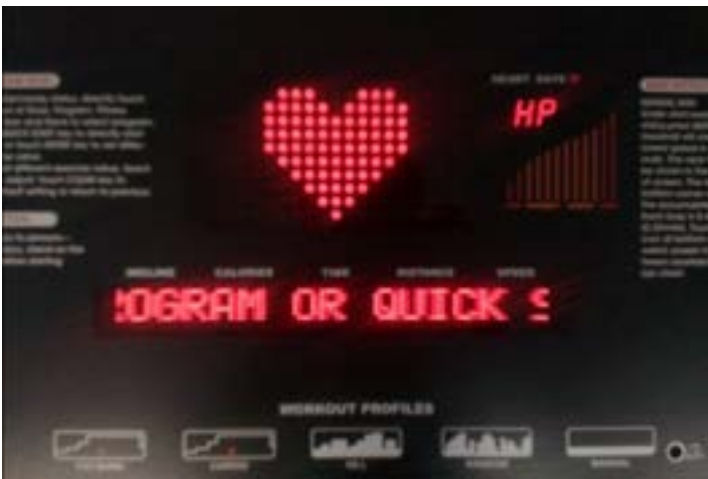

PS. Metric/imperial switching , change PROGRAM, setting ENTER WEIGHT

<34-181> KG/ WEIGHT <70-400> LB