

# ***PARTS***

# ***MANUAL***

---

V SQUAT  
CPL-VSQ-901

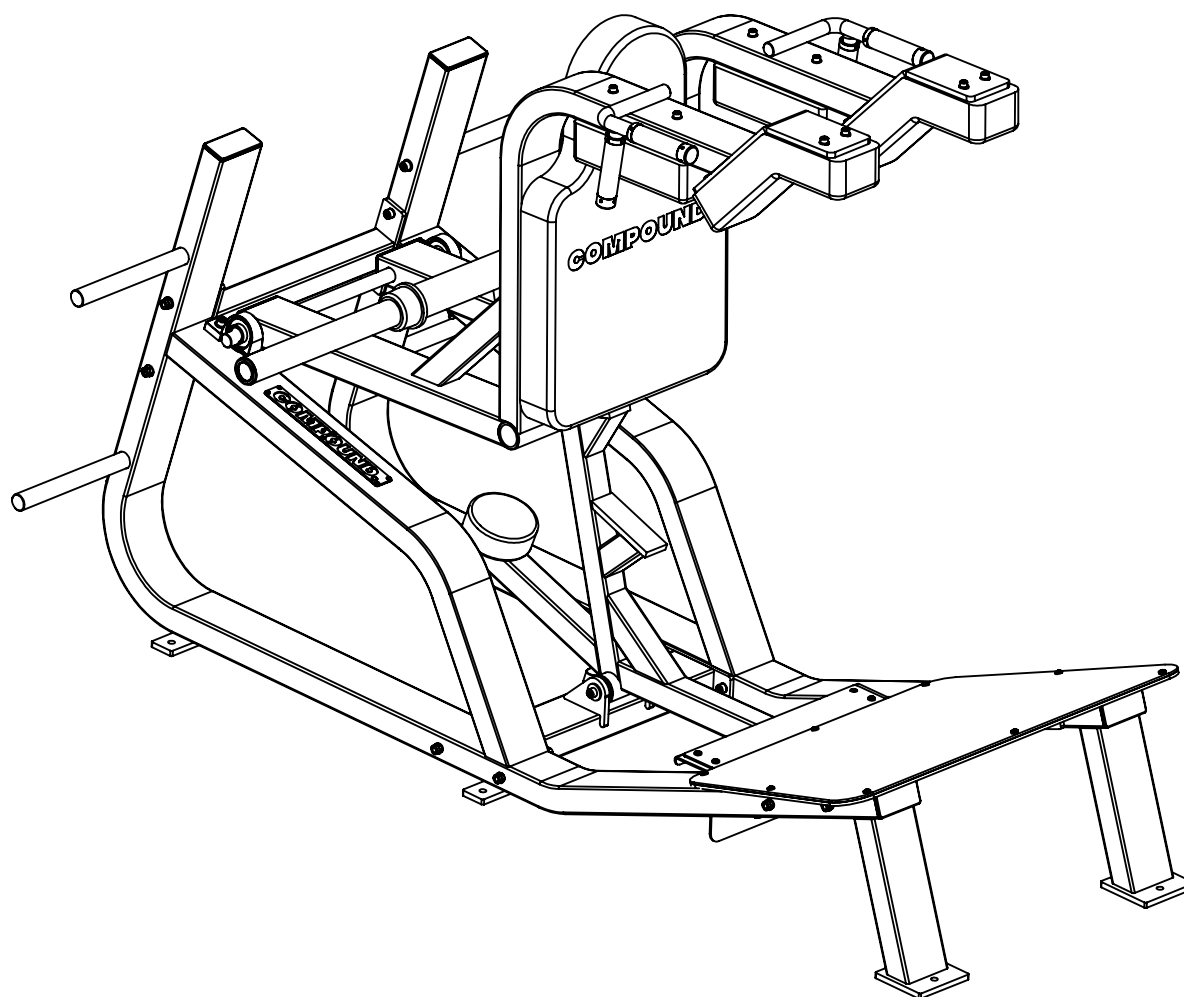

---

**CAUTION:** Read all precautions and instructions before using  
this equipment. Save this manual for future reference.

# ***CONTENTS***

02 General warnings and maintenance advice

03-06 Assembly Instructions

Explained as a series of steps, with each step containing:

◆ Pictures, descriptions and quantities of the parts required

◆ Notes

07 Part List

# *Assembly Instructions*

## *Before Your Begin*

This exercise equipment is built for optimum safety. Be sure to read the entire manual before you assemble or operate your equipment. Please note the following safety precautions:

1. Keep children and pets away from the equipment at all times. Do not leave children unattended in the same room with the equipment.
2. Only one person at a time should use the equipment.
3. If the user experiences dizziness, nausea, chest pain, or any other abnormal symptoms stop the workout at once.
4. Position the equipment on a clear, level surface. Do not use the equipment near water or outdoors.
5. Keep hands away from all moving parts.
6. Always wear appropriate workout clothing when exercising. Do not wear robes or other clothing that could become caught in the equipment.
7. Use the equipment only for its intended use as described in this manual. Do not use attachments not recommended by the manufacturer.
8. Before using the equipment, always do stretching exercises to properly warm up.
9. Never operate the equipment if the equipment is not functioning properly.

**NOTE:** In this step, all the washers and nuts which are not marked are W10 and N10

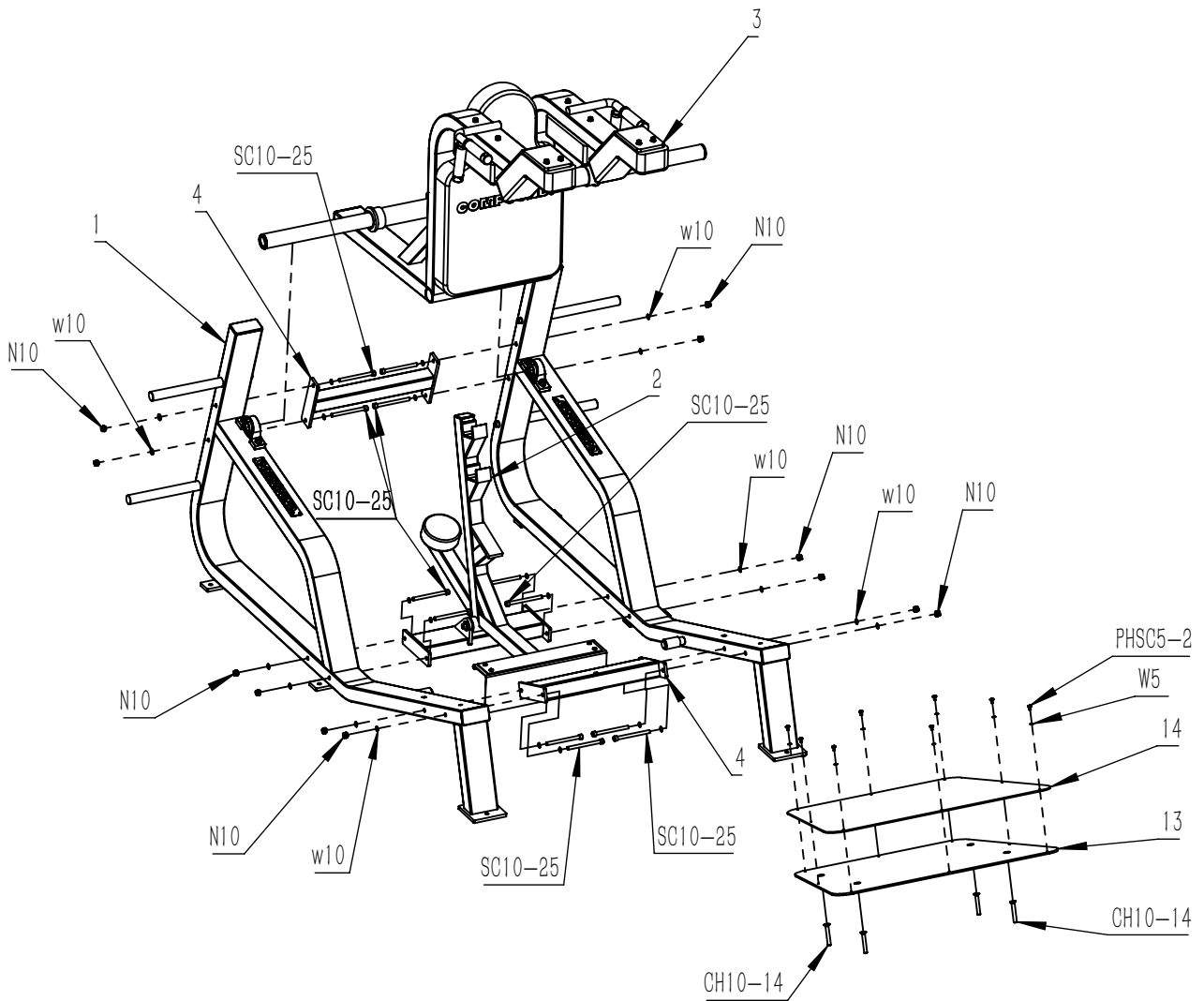

### INFORMATION

- ◆ We recommend you have someone assist you in lifting and assembling your gym.
- ◆ Follow these steps carefully and it will make it easier to assemble your gym.

**STEP 1**

**NOTE:** In this step, all the washers and nuts which are not marked are W10 and N10

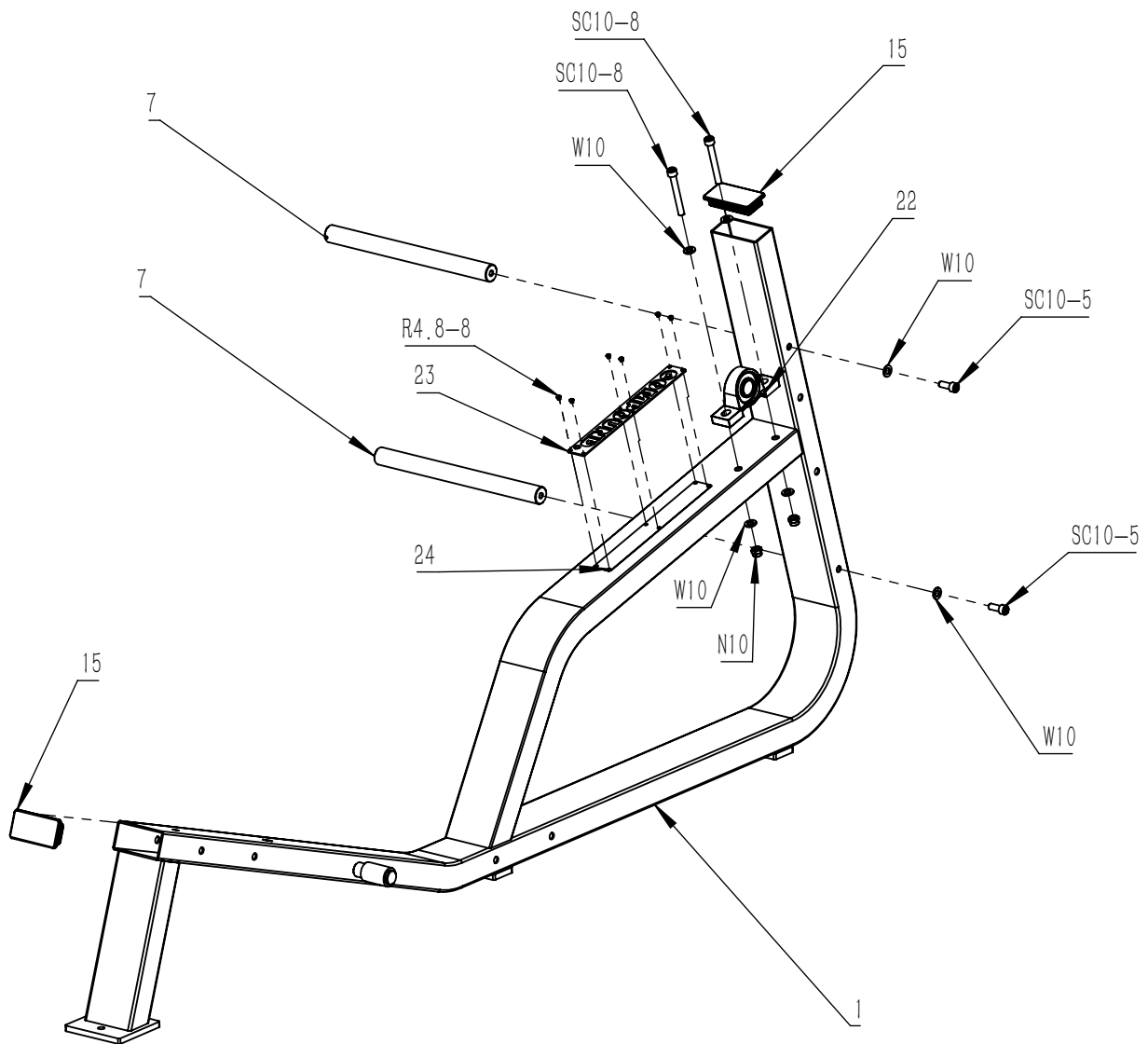

### INFORMATION

- ◆ We recommend you have someone assist you in lifting and assembling your gym.
- ◆ Follow these steps carefully and it will make it easier to assemble your gym.

**STEP 2**

**NOTE:** In this step, all the washers and nuts which are not marked are W10 and N10

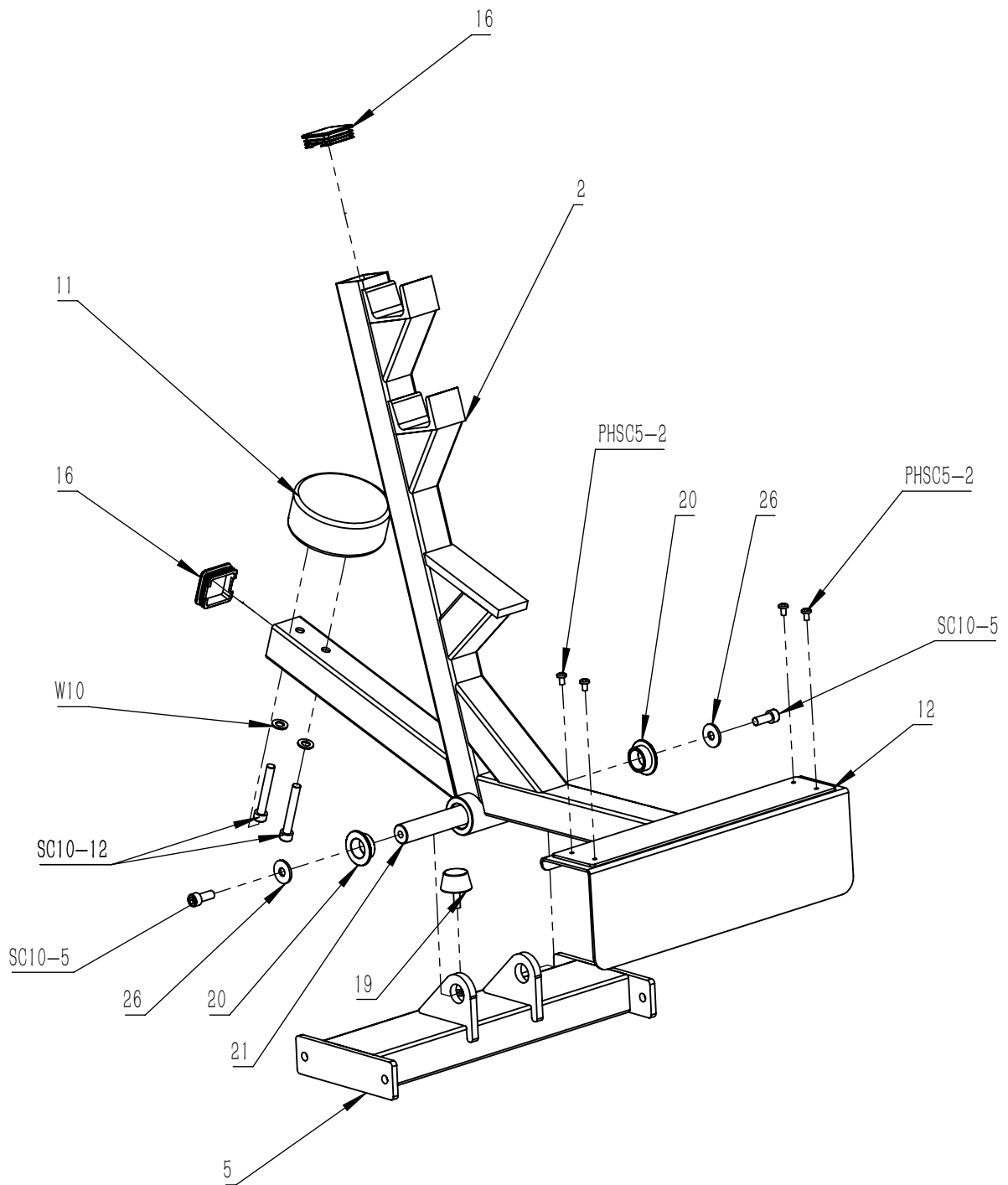

### INFORMATION

- ◆ We recommend you have someone assist you in lifting and assembling your gym.
- ◆ Follow these steps carefully and it will make it easier to assemble your gym.

**STEP 3**



