



[edwardsvacuum.com](http://edwardsvacuum.com)

# Dry Vacuum Pumps nXR60i and nXR90i

INSTRUCTION MANUAL

## Copyright notice

©Edwards Limited 2019. All rights reserved.

## Trademark credit

Edwards and the Edwards logo are trademarks of Edwards Limited, Innovation Drive, Burgess Hill, West Sussex RH15 9TW.

## Disclaimer

The content of this manual may change from time to time without notice. We accept no liability for any errors that may appear in this manual nor do we make any expressed or implied warranties regarding the content. As far as practical we have ensured that the products have been designed and constructed to be safe and without risks when properly installed and used in accordance with their operating instructions.

We accept no liability for loss of profit, loss of market or any other indirect or consequential loss whatsoever.

Product warranty and limit of liability are dealt with in our standard terms and conditions of sale or negotiated contract under which this document is supplied.

You must use this product as described in this manual. Read the manual before you install, operate, or maintain the product.

## CE Declaration of Conformity

Edwards Ltd  
Innovation Drive  
Burgess Hill  
West Sussex  
RH15 9TW  
UK

The following product

nXR60i 100-127/200-240V 1ph 50/60 Hz NW40 Inlet	A 905 02 983
nXR90i 100-127/200-240V 1ph 50/60 Hz NW40 Inlet	A 906 02 983

Is in conformity with the relevant requirements of European CE legislation:

2006/42/EC	Machinery directive
2014/35/EU	Low voltage directive (LVD) as applicable to electrical sub-assemblies
2014/30/EU	Electromagnetic compatibility (EMC) directive
2011/65/EU	Restriction of certain hazardous substances (RoHS) directive as amended by Delegated Directive (EU) 2015/863

Based on the relevant requirements of harmonised standards:

EN 1012-2:1996 +A1:2009	Compressors and vacuum pumps. Safety requirements. Vacuum pumps
EN 61010-1:2010	Safety requirements for electrical equipment for measurement, control and laboratory use. General requirements
EN 61326-1:2013	Electrical equipment for measurement, control and laboratory use. EMC requirements. General requirements Class A Emissions, Industrial Immunity

Documentation Officer: Jelena Havelkova, Spielberk Office Centre, Holandska 10, Brno, 63900 Czech Republic,  
☎: +42(0) 734 418 896, ✉: documentation@edwardsvacuum.com

This declaration, based on the requirements of the listed Directives and EN ISO/IEC 17050-1, covers all product serial numbers from this date on: 6<sup>th</sup> February 2020.



Petr Smerek - Engineering Manager  
Scientific Vacuum Division  
Lutin



Nin Buta – General Manager  
Lutin

# Additional Legislation and Compliance Information

## EU EMC Directive: Class A Industrial equipment

Caution: This equipment is not intended for use in residential environments and may not provide adequate protection to radio reception in such environments.

## EU RoHS Directive: Material Exemption Information

This product is compliant with the following Exemptions

Annex III:

- 6(a) **Lead** as an alloying element in steel for machining purposes and in galvanised steel containing up to 0.35 % lead by weight
- 6(b) **Lead** as an alloying element in aluminium containing up to 0.4% by weight
- 6(c) Copper alloy containing up to 4% **lead** by weight

## EU REACH Regulation Compliance

This product is a complex article which is not designed for intentional substance release. To the best of our knowledge the materials used comply with the requirements of REACH. The product manual provides information and instruction to ensure the safe storage, use, maintenance and disposal of the product including any substance based requirements.

## Article 33 Declaration

This product does contain Candidate List Substances of Very High Concern above 0.1%ww by article as clarified under the 2015 European Court of Justice ruling in case C-106/14.

- Lead (Pb) added to the Candidate List June 2018

As indicated by the applied RoHS exemption(s) above this substance is present in certain aluminium/brass/steel/ components.

### ADDITIONAL INFORMATION

The products listed are also in scope for and comply with the requirements of the following:

2012/19/EU	Directive on waste electrical and electronic equipment (WEEE)
Product is certified to CSA-C22.2 No.61010-1-12	Safety requirements for electrical equipment for measurement, control and laboratory use – Part 1: General requirements
Product conforms to UL61010-1 3 <sup>rd</sup> Edition	Safety requirements for electrical equipment for measurement, control and laboratory use – Part 1: General requirements

材料成分声明

China Material Content Declaration

部件名称 Part name 	有害物质 Hazardous Substances					
	铅 Lead (Pb)	汞 Mercury (Hg)	镉 Cadmium (Cd)	六价铬 Hexavalent Chromium (Cr VI)	多溴联苯 Polybrominated biphenyls (PBB)	多溴二苯醚 Polybrominated diphenyl ethers (PBDE)
铸铝及铝合金制品 Aluminium alloys	X	O	O	O	O	O
铜管管件 Brass pipe fitting	X	O	O	O	O	O
铜接头 Brass connectors	X	O	O	O	O	O

O: 表示该有害物质在该部件的所有均质材料中的含量低于 GB/T 26572 标准规定的限量要求。  
O: Indicates that the hazardous substance contained in all of the homogeneous materials for this part is below the limit requirement in GB/T 26572.

X: 表示该有害物质在该部件的至少一种均质材料中的含量超出 GB/T26572 标准规定的限量要求。  
X: Indicates that the hazardous substance contained in at least one of the homogeneous materials used for this part is above the limit requirement of GB/T26572.

This page has been intentionally left blank.

# Contents

<b>1. Safety and compliance.</b> . . . . .	<b>6</b>
1.1 Definition of Warnings and Cautions. . . . .	6
1.2 Safety symbols. . . . .	6
<b>2. General description.</b> . . . . .	<b>7</b>
2.1 Overview. . . . .	7
2.2 Pump controller. . . . .	8
2.3 Interface control panel. . . . .	9
2.3.1 Auxiliary connector socket. . . . .	9
2.4 Logic interface. . . . .	10
2.5 Auto-run. . . . .	11
2.6 Pump controller configuration. . . . .	11
<b>3. Technical data.</b> . . . . .	<b>12</b>
3.1 Operating and storage conditions. . . . .	12
3.2 Performance. . . . .	13
3.3 Materials exposed to gases pumped. . . . .	14
3.4 Electrical data. . . . .	14
<b>4. Installation.</b> . . . . .	<b>15</b>
4.1 Installation safety. . . . .	15
4.2 Unpack and inspect. . . . .	15
4.3 Mechanical installation. . . . .	16
4.4 Leak test the system. . . . .	18
4.5 Electrical installation. . . . .	19
4.5.1 Pump voltage setting. . . . .	19
4.5.2 Connect the electrical supply. . . . .	20
4.6 Connection for remote control and monitoring. . . . .	20
<b>5. Commission the pump.</b> . . . . .	<b>21</b>
<b>6. Operation.</b> . . . . .	<b>22</b>
6.1 Operation safety. . . . .	22
6.2 Operational modes. . . . .	22
6.2.1 Manual control mode. . . . .	23
6.3 Logic interface data. . . . .	24
6.4 Parallel control and monitoring. . . . .	26
6.5 Analogue speed control. . . . .	27
6.6 Hardware configuration. . . . .	28
6.7 Operational modes. . . . .	28

6.8 Start the pump. . . . .	29
6.9 Shut down the pump. . . . .	29
6.10 Restart the pump. . . . .	30
<b>7. Maintenance and service. . . . .</b>	<b>31</b>
7.1 General maintenance. . . . .	31
7.2 Maintenance plan. . . . .	31
7.3 Inspect and clean the inlet strainer. . . . .	31
7.4 Clean the external fan grill. . . . .	32
7.5 Replace the pump bearings. . . . .	32
7.6 Replace the pump controller. . . . .	32
7.7 Electrical safety check. . . . .	32
7.8 Service indicator codes. . . . .	32
7.9 Service. . . . .	33
7.9.1 Return the equipment or components for service . . . . .	33
<b>8. Fault finding. . . . .</b>	<b>34</b>
8.1 The pump has failed to start or has stopped. . . . .	34
8.2 The pump has failed to achieve the required performance. . . . .	34
8.3 The pump is noisy. . . . .	34
8.4 The pumping speed is poor or pump down time is too long. . . . .	35
8.5 Alarm indicator codes. . . . .	35
<b>9. Storage. . . . .</b>	<b>37</b>
<b>10. Disposal. . . . .</b>	<b>38</b>
<b>11. Accessories. . . . .</b>	<b>39</b>
11.1 Electrical cables. . . . .	39



## List of Figures

Figure 1: nXRi pumps. . . . .	8
Figure 2: Interface panel. . . . .	9
Figure 3: Valve connector. . . . .	10
Figure 4: Dimensions. . . . .	12
Figure 5: nXR60i Performance curve. . . . .	13
Figure 6: nXR90i Performance curve. . . . .	14
Figure 7: Voltage selection plate. . . . .	20
Figure 8: Logic interface connections - parallel control. . . . .	27
Figure 9: Logic interface connections - analogue speed control. . . . .	27
Figure 10: Analogue speed control. . . . .	28

# 1. Safety and compliance

## 1.1 Definition of Warnings and Cautions

Important safety information is highlighted as WARNING and CAUTION instructions. These instructions must be obeyed.

The use of WARNINGS and CAUTIONS is defined below.



### **WARNING:**

Warnings are given where failure to observe the instruction could result in injury or death to people. The actual symbol shown varies according to the hazard.



### **CAUTION:**

Cautions are given where failure to observe the instruction could result in minor injury or damage to the equipment, associated equipment or process.

## 1.2 Safety symbols

The safety symbols on the products shows the areas where care and attention is necessary.

The safety symbols that follow are used on the product or in the product documentation.

	Warning/Caution An appropriate safety instruction must be followed or caution to a potential hazard exists.
	Warning - Heavy object Indicates the potential hazard arising from a heavy object.
	Warning - Dangerous voltage Indicates hazards arising from dangerous voltages.
	Warning - Protective earth (ground) Indicates that the equipment must be grounded.
	Warning - WEEE symbol Indicates that the equipment must be disposed of carefully.
	Warning - Use protective equipment Indicates that appropriate protective equipment must be used.

## 2. General description

### 2.1 Overview



#### **WARNING: INCORRECT USE OF EQUIPMENT**

**Risk of injury or damage to the equipment. Incorrect use of the equipment can cause damage to the equipment or injury to people. The user is responsible for the safe operation, installation and monitoring of the system.**

The nXRi product family is a range of dry, multi-stage roots vacuum pumps that gives high pumping density in a compact form. The pump is connected by a cord and is designed for use on clean duty applications.

The cord ratings are:

Supply voltage (V)	Current (A)	Frequency (Hz)
100 - 127	14	50 or 60
200 - 240	7	

The pump is not designed for use with flammable, corrosive, toxic or other hazardous gases. Gas or oxygen can mix in the pump system.

The dry-pumping system operates in steady-state gas load conditions. The pump can sustain continuous operation with a maximum power consumption of 850 W. If the inlet pressure exceeds the specified pressure, the pump controller reduces the motor speed. The motor speed is increased when the pressure is reduced, or when the transient overload protection has recovered. Refer to [Table: Performance data](#) on page 13 for information on maximum inlet pressure.

Refer to [Figure: nXRi pumps](#) on page 8, the system is supplied with either a NW40 inlet port (1) and a NW25 exhaust port (10).

The pump mechanism is operated by a three-phase electric motor. The pump controller controls the motor.

The system is air cooled by a fan installed internally in the pump enclosure. The pump has a thermal protection device that will stop the motor if a thermal overload, for example in high ambient temperature occurs. You must restart the pump after the pump is cooled down.

The pump is designed to pump the residual gases used in high vacuum systems. The gases are:

- Air
- Nitrogen
- Krypton
- Argon
- Helium

You can use the pump to pump water vapour. You must use the gas ballast when water vapour is pumped. The water vapour must not condense in the pump.

To use the pump for a gas that is not listed, contact the supplier for advice. Failure to contact the supplier can invalidate the warranty of the pump. Do not use the pump for aggressive or corrosive gases.

Figure 1 nXRi pumps

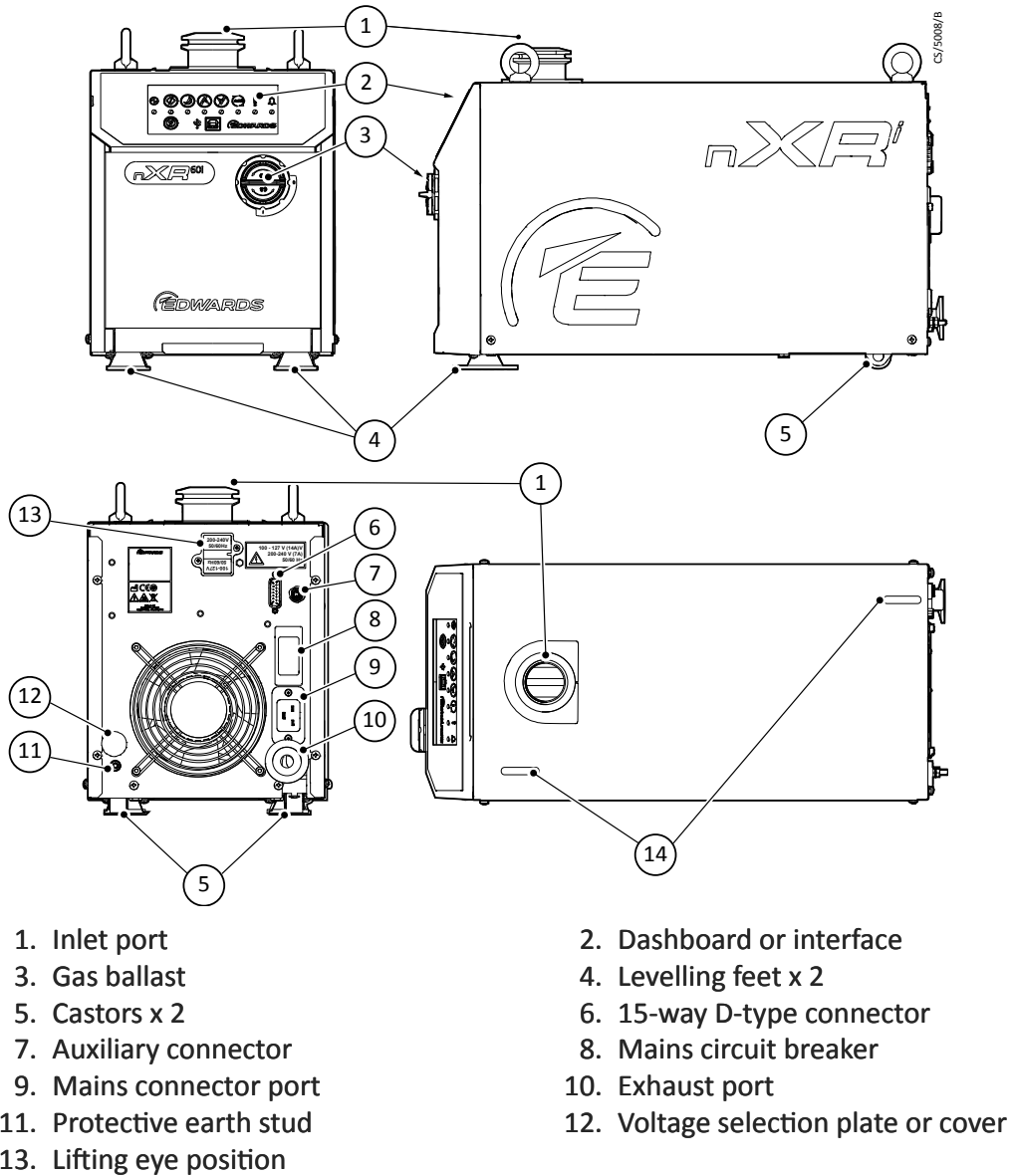

## 2.2 Pump controller

The pump controller contains the drive electronics to controls the pump operation. The pump controller controls the supply of electric current to the motor as per the operating conditions.

The interface control panel is installed on the pump controller. The pump can be operated:

- manually, with the buttons on the user interface control panel. Refer to [Figure: Interface control panel](#) on page 9.

- remotely, with the serial communications or digital and analogue process control (parallel), through the 15-way D-type interface connector. Refer to [Connection for remote control and monitoring](#) on page 20.

## 2.3 Interface control panel

Figure 2 Interface panel

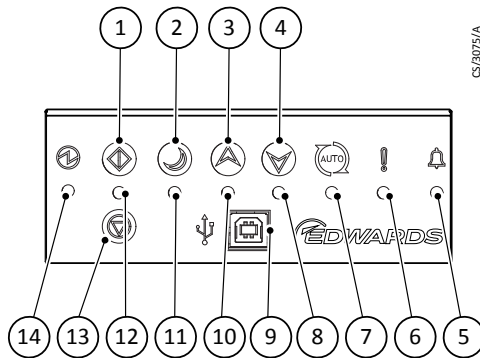

- |                                 |                                    |
|---------------------------------|------------------------------------|
| 1. Start button                 | 2. Standby button                  |
| 3. Standby increase button      | 4. Standby decrease button         |
| 5. Alarm indicator LED          | 6. Service indicator LED           |
| 7. Auto-run indicator LED       | 8. Standby decrease indicator LED  |
| 9. USB port (not for operation) | 10. Standby increase indicator LED |
| 11. Standby indicator LED       | 12. Run indicator LED              |
| 13. Stop button                 | 14. Power status LED               |

### 2.3.1 Auxiliary connector socket

An auxiliary control connection on the rear panel controls an optional inlet valve. This inlet valve can be operated in parallel with the normal pump output signal. Refer to [Figure: nXRi pumps](#) on page 8, (7). The valve is usually closed and:

- will open when the normal signal becomes active (pump at speed)
- will close when you select the stop button or if there is a fault condition

The reaction time will be in line with the valve selection and the output signal is 24 V d.c. Refer to [Figure: Valve connector](#) on page 10 for polarity of the connector pins when the connector is energized.

The auxiliary connector is regulated to 24 V d.c. to control the accessories. If the auxiliary load current exceeds the value in [Table: Auxiliary load currents](#) on page 10, the output will shut down to protect the pump controller. Refer to [Table: Recommended mating plugs](#) on page 10 for the recommended mating plugs.

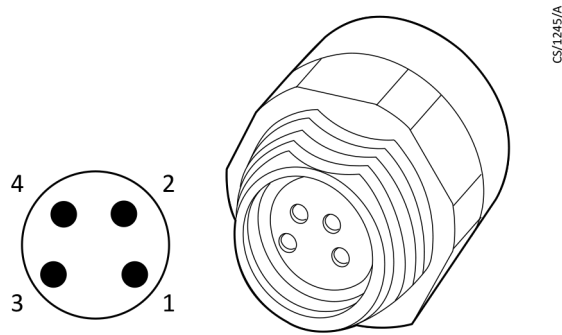
**Figure 3** Valve connector

Pin number	Signal	Polarity
1	Valve 1 - Control output	Positive
2	Valve 2 - Control output	Positive
3	Valve 1 - Return	Negative
4	Valve 2 - Return	Negative

**Table 1** Auxiliary load currents

Description	Data
Connector plug	Phoenix part number SACC-DSI-M 8FS-4CON-M12/0.5
Voltage output	24 V d.c. -25%, +10% (18 V d.c. to 26.4 V d.c.)
Output power	2 Channels with 4 watts per channel

**Table 2** Recommended mating plugs

Mating connector plug	Phoenix part number
Screw connection, straight	SACC-M 8MS-4CON-M-SW
Solder connection, straight	SACC-M 8MS-4CON-M
Screw connection, right angle	SACC-M 8MR-4CON-M-SW
Solder connection, right angle	SACC-M 8MR-4CON-M

## 2.4 Logic interface

The logic interface is designed to support the serial control, the parallel control, monitor and operate through one connector.

The pump controller can be operated through the 15-way D-type logic interface connector. The signals on the logic interface are:

- control inputs: switch type and analogue signals that controls the pump.
- status outputs: to identify the status of the system Tab.

For serial control select RS232 or RS485.

For control modes refer to [Table: Manual control mode](#) on page 23.

For logic interface data refer to [Logic interface data](#) on page 24.

## 2.5 Auto-run

The auto-run setting configures the pump to start automatically when the power is switched on, without any customer intervention.

You can configure the auto-run through serial communications, or with the start or stop button. Push and hold the start or stop button for more than eight seconds to enable or disable the auto-run setting. The auto-run LED displays the auto-run setting.

The pump can be stopped by either manual, parallel or serial control modes when in auto-run mode.

## 2.6 Pump controller configuration

The integral pump controller monitors the power and temperature of the pump. The pump controller protects the user and the pump when the pump is operated under sustained high load or in fault conditions.

The pump controller has the interface control panel and the pump can be operated:

- manually, with the buttons on the user interface control panel. Refer to [Figure: Interface control panel](#) on page 9.
- remotely, through serial communications or digital and analogue process control (parallel), via the 15-way D-type interface connector. Refer to [Connection for remote control and monitoring](#) on page 20.

## 3. Technical data

### 3.1 Operating and storage conditions

**Table 3** Operating and storage conditions

Range	Data
Ambient operating temperature range	5 °C to 40 °C
Ambient operating humidity range	80% up to 31 °C Reducing linearly to 50% at 40 °C
Maximum operating altitude	3000 m
Ambient storage temperature range	-30 °C to 70 °C
Maximum humidity (storage in original packaging)	≤ 95 % RH
Equipment type	Indoor use
Enclosure protection	IP20

**Table 4** Environmental conditions

Pollution	Pollution degree 2
Installation	Installation category II
Altitude restriction	Maximum 3000 m
Area of use	Indoor

**Table 5** Mechanical data

	nXR60i	nXR90i
Mass	29.5 kg	30 kg
Inlet connection	NW40	
Overall dimensions (L x W x H)	494 x 217 x 301 mm	
Maximum tilt angle for operation	+/- 5°	
Maximum tilt angle for transport	30°	
Nominal rotational speed	15000 rpm	
Outlet connection	NW25	

**Figure 4** Dimensions

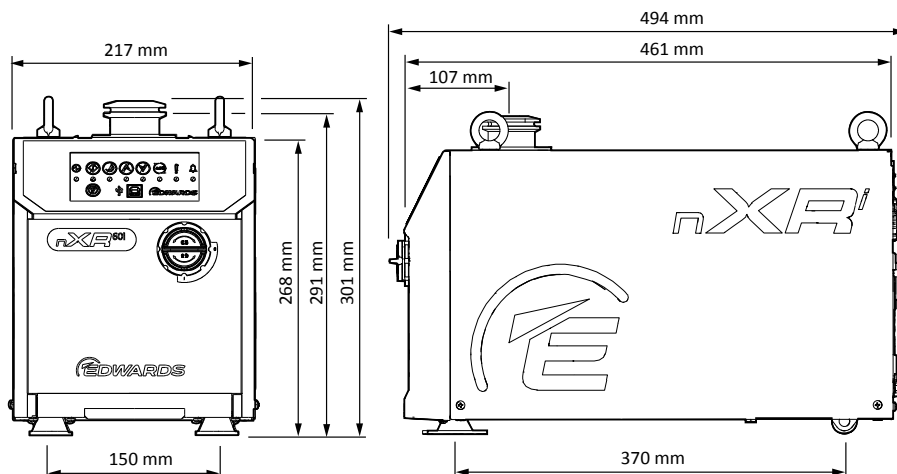



### 3.2 Performance

**Table 6** Performance data

	nXR60i	nXR90i
Maximum pumping speed (m <sup>3</sup> /hr)*	60	90
Maximum continuous inlet pressure ambient (mbar)	1013	
Maximum chamber size for evacuation (l)	No limit	
Time to evacuate 40 l chamber from 1000 mbar to 0.1 mbar (s)**	40	
Maximum continuous exhaust pressure (mbar)	200	
Suck-back protection	Exhaust valve design	
Leak tightness (static) (mbar l/s )	< 1x10 <sup>-6</sup>	

\* Values for maximum pumping speed are obtained with the inlet strainer. The pumping speed is measured at standard ambient temperature and pressure. At higher temperature or different ambient pressures pump performance may be compromised and the rotational speed may drop below nominal.

\*\* contact us if the value for your pump is more than the specified value.

**Table 7** Sound data

Declared dual-number noise emission values in accordance with ISO 4871		
	nXR60i	nXR90i
Measured A-weighted emission sound pressure level, L <sub>pA</sub> at ultimate vacuum 1 m from the pump in free space	55.0 dB(A)	
Measured A-weighted emission sound pressure level, L <sub>pA</sub> at 15 mbar at inlet 1 m from the pump in free space	57.0 dB(A)	
Uncertainty, K <sub>pA</sub>	2.5 dB(A)	
Values from ISO 3744: 2010		

**Figure 5** nXR60i Performance curve

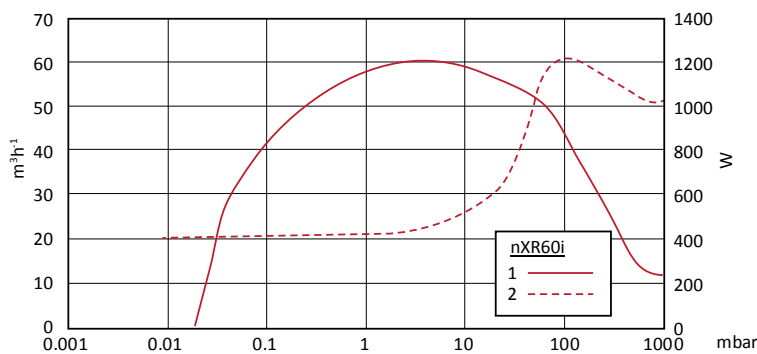

1. Pumping speed

2. Power

Figure 6 nXR90i Performance curve

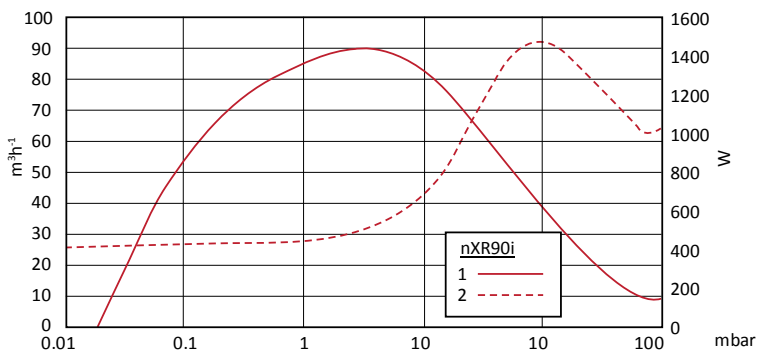

1. Pumping speed

2. Power

### 3.3 Materials exposed to gases pumped

The materials and the components exposed to the gases in the pump are:

- Iron
- Aluminium alloy
- Steel
- Fluoroelastomer (seals)
- PFPE lubricant

### 3.4 Electrical data

Table 8 Electrical rating for continuous operation

Pump	Supply voltage (V a.c. rms)	Phase	Frequency (Hz)	Input current (A rms)
All variants	200 - 240 ± 10%	Single	50 or 60	7.0
	100 - 127 ± 10%	Single	50 or 60	14.0

Table 9 Recommended regional supply protection

Area	Voltage	Rating
UK	230 V	10 A, 250 V a.c. rms
Europe	230 V	10 A, 250 V a.c. rms
US	120 V	16 A, 250 V a.c. rms
Japan	100 V	16 A, 250 V a.c. rms

## 4. Installation

### 4.1 Installation safety



#### CAUTION: SAFETY INSTRUCTIONS

**Follow all safety instructions and take note of all appropriate precautions.**

Possible hazards on the dry pumping system include electricity, process chemicals, and Fomblin® (PFPE) oil:

- Refer to the safety manual P40040100 for safety information for the specification, design, operation and maintenance of vacuum pumps and vacuum systems. Contact us for the safety manual.
- Contact us or the local service centre for more information for advice or assistance on installation.
- Do not remove the temporary covers from the system inlet and exhaust until ready to connect.
- Do not operate the system unless the inlet and exhaust are connected to the vacuum and exhaust extraction system.
- Isolate the other components in the process system from the electrical supply to prevent accidental operation.
- Electrical supplies are potentially hazardous energy sources. Lockout and tagout before you do the maintenance.
- Obey all national and local rules and safety regulations when you install the system.
- Tighten the cables, hoses and pipework during installation to prevent a trip hazard.
- Make sure that the installation area is clean and free from debris and contamination before you install the pump.
- Make sure that all facilities given in this manual are available for the system to perform correctly.



#### WARNING: BLOCKED EXHAUST PIPELINE

**Risk of damage to equipment. Make sure the exhaust pipeline is not blocked. If an exhaust isolation valve is used, make sure that the pump is not operated with the valve closed.**

### 4.2 Unpack and inspect



#### WARNING: DAMAGED PUMP

**Risk of injury to people or damage to equipment. Do not use the pump if it is damaged. Failure to do so can result in injury to people and/or damage to equipment.**

**CAUTION: PUMP LIFE**

**Risk of damage to equipment. Unpack the pump carefully and avoid excessive shock to the pump. Excessive shock will damage the bearings and reduce the life of the pump.**

Refer to [Table: Mechanical data](#) on page 12 for the mass of the pump.

The pump is supplied in a recyclable packaging.

1. Open the cardboard box from the top.
2. Remove the packing material. Keep all the packing materials for use in inspection and if the pump is returned for service.
3. Examine the pump for damage. If the pump is damaged, notify your supplier and the carrier immediately. Give the supplier and the carrier the information that follows:
  - part number of the pump
  - serial number of the pump
  - order number
  - supplier's invoice number
4. Do not use the pump if the pump is damaged.
5. Check that the package has the items listed in [Table: Checklist of items](#) on page 16. If any of these items are missing, notify the supplier in writing within three days.
6. If the pump is not to be used immediately, store the pump in the conditions given in [Storage](#) on page 37.
7. Do not remove the seals until the pump is ready to be installed on the vacuum system. The pump is supplied with sealed inlets and outlet to prevent the entry of dust and vapour.

**Table 10** Item checklist

Quantity	Description	Check
1	nXRi vacuum pump	<input type="checkbox"/>
2	Lifting eye	<input type="checkbox"/>
1	Instruction manual CD (P45000000)	<input type="checkbox"/>

### 4.3 Mechanical installation

**WARNING: HEAVY OBJECT**

**Risk of physical injury. Use suitable equipment to lift the pump.**

**WARNING: LOOSE CABLES/PIPEWORK**

**Tripping hazard. Make sure that any cables and/or pipe work attached to the pump are fixed carefully to avoid a slip/trip hazard and to prevent any damage to the cable.**



**WARNING: LIFTING EYE INTEGRITY**

Risk of injury or damage to equipment. Make sure that the maximum angle between the paired slings used to lift the system is 45 degrees. Increased angle could compromise the lifting eye integrity.



**WARNING: INSTALLATION SAFETY**

Risk of injury or damage to equipment. Install the pump in the vacuum system before you connect the pump to the power supply. This will make sure that the pump is not operated and injure people during installation.



**WARNING: STATIC PRESSURE**

Risk of damage to equipment. Do not step or stand on the pump, it is not designed to withstand large static loads.



**WARNING: HEAVY OBJECT**

Push-pull hazard with strain injury. Push or pull the pump system only for short distance and over flat surfaces. Lift the system if the floor is uneven or has obstacles.



**WARNING: EXHAUST BLOCKAGE**

Risk of injury or damage to equipment. A peak pressure of 3 bar(g) can be generated in the pump if the exhaust or pipework attached to the exhaust are blocked.



**WARNING: HAZARDOUS SUBSTANCES**

Risk of explosion. The pump is intended for clean applications only. It is not suitable for use with hazardous production materials.



**CAUTION: INSTALLATION SAFETY**

Risk of injury or damage to the environment. Follow all local legislation when the pump is installed or removed to reduce the impact of the pump on the environment.



**CAUTION: CONDENSATE DRAINAGE**

Risk of damage to equipment. Use a catchpot to prevent the drainage of condensate back into the system. Condensate that drains back into the system could damage the pump.

Obey the instructions that follow when you install the pump:

- Make sure that there is no blockage to access the pump electrical supply cable or the other controls.
- Make sure that there is a minimum air gap of 100 mm on all sides of the pump to allow effective air circulation.

- Make sure that the system is on a firm and levelled surface that can support the mass of the pump.
- Make sure that the system is installed away from combustible materials.
- Level the pump to a maximum of 5 degrees (measured at the pump inlet).
- You must do a risk assessment of the location and make sure that you can move the pump safely and as per the local and national manual handling guidelines.

To move the pump:

1. Use suitable lifting equipment attached to lifting eyebolts (*Figure: nXRi pumps* on page 8, (14)) to move the dry pump system close to its final operating position. Refer to *Table: Mechanical data* on page 12 for pump mass.
2. Secure the dry pump system with the rubber stand-off and two small castors (*Figure: nXRi pumps* on page 8, (5)).
3. Remove the plastic caps from the inlet and exhaust before you connect the pump to the vacuum system. Use appropriate NW vacuum fittings for connection to the system.

Obeys the instructions that follows when you connect the pump to the vacuum system:

- Connect the pump to an exhaust line to minimize the noise and the exhaust emissions.
- Make sure that the pipeline connected to the pump inlet is as short as possible. Make sure that the pipeline has a minimum internal diameter to get maximum pump speeds.
- Put support under the vacuum pipeline to prevent the load on the coupling joints.
- Make sure that the pump exhaust line is not blocked as a pressure of 3 bar(g) can be generated in the exhaust pipework. Connect the pump with appropriate pipework and fittings.
- If necessary, install flexible bellows in the system pipelines to reduce the transmission of the vibration and to prevent the load on the coupling joints. The pressure rating of the bellows must be higher than the highest pressure generated in the system. We recommend that you use the manufacturer's bellows.
- Make sure that the sealing surfaces are clean and are not scratched.
- We recommend that you use an exhaust extraction system appropriate for use with all pumped process gases. Make sure that the exhaust extraction system is not blocked or obstructed when the pump is in operation.

## 4.4 Leak test the system



### CAUTION: SYSTEM LEAK TEST

**Risk of injury or damage to equipment. Do the leak test of the system after installation. Seal all the leaks found to prevent leakage of dangerous substances out of the system and leakage of air into the system.**

We will accept no liability or warranty claims for damages caused from flammable mixtures because of air leaks.

1. Do the leak test of the vacuum system after installation.
2. Seal all the leaks found.

## 4.5 Electrical installation



### **WARNING: ELECTRICAL CONNECTION**

Risk of electric shock. The electrical installation must be done by a qualified person. Always make the electrical connections to the pump after the pump has been installed on the vacuum system.



### **WARNING: INSTALLATION SAFETY**

Risk of electric shock or damage to equipment. The pump must be electrically installed in accordance with regional and local codes, and must obey the local and national safety requirements.



### **WARNING: HAZARDOUS VOLTAGE**

Risk of electric shock or damage to equipment. The logic interface is 30 V maximum rated PELV and must only be connected to PELV interfaces. Failure to use an correctly rated supply could result in electric shock.

The pump is a cord-connected device and must be installed in accordance with local electrical regulations. Refer to [Table: Recommended cord sets](#) on page 39.

The pump is supplied from a single phase 100 - 127 V a.c./200 - 240 V a.c. mains supply system. The branch circuit, supplying the pump, must be protected with a 10 A (200 - 240 V) or 16 A (100 - 127 V) branch circuit protection.



### **WARNING: ELECTRICAL CONNECTION**

Risk of electric shock. Make sure that the pump is switched off and not connected to the electrical supply when you select the mains voltage.

### 4.5.1 Pump voltage setting

To set the correct voltage:

1. Isolate the pump from electrical supply.
2. Remove the screws on the voltage selection plate.
3. Rotate the voltage selection plate to point towards the required voltage setting (refer to [Figure: Voltage selection plate](#) on page 20).

The selector cover plate will make sure that the rocker switch below the plate is set to the correct voltage.

4. Make sure that the screws are tightened and the voltage selection plate is fully secured before you operate the pump.

Figure 7 Voltage selection plate

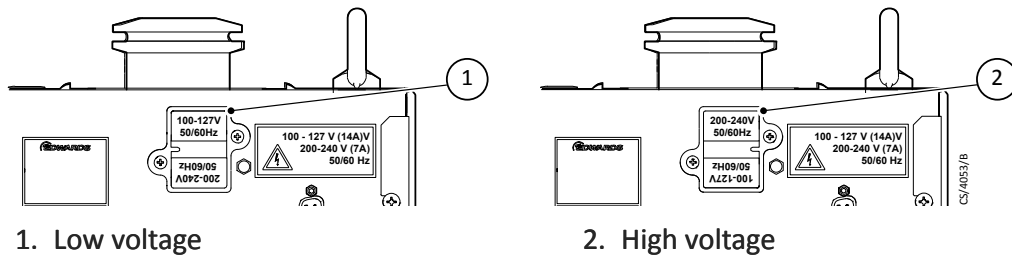

#### 4.5.2 Connect the electrical supply



#### **WARNING: PROTECTIVE EARTH CONNECTION**

Risk of electric shock. Make sure that the pump and electrical cables are suitably protected against earth (ground) faults. We recommend you attach a protective earth (ground) conductor (with a cross sectional area of 2.5 mm<sup>2</sup>/14 AWG) to the protective earth (ground) stud.

Make the electrical connection to the pump mains connector port (*Figure: nXRi pumps* on page 8, (10)) with an appropriate cord set. Refer to *Table: Recommended cord sets* on page 39.

The pump must be grounded through the conductor of the mains input connector.

#### 4.6 Connection for remote control and monitoring

To operate the pump with parallel or serial control, the 15-way D-type connector must be used (*Figure: nXRi pumps* on page 8, (8)).

Refer to *Figure: Logic interface connections - analogue speed control* on page 27 for details of the logic interface pins.



## 5. Commission the pump

To commission the pump:

1. Make sure that the voltage selection is set to correct value required for the application. Refer to [Figure: Voltage selection plate](#) on page 20.
2. Make sure that the exhaust extraction system is not blocked (for example, that valves in the exhaust extraction system are open).
3. Make sure that all openings to atmospheric pressure in the foreline vacuum system are closed.
4. Set the external electrical supply to ON.
5. Set the mains circuit breaker ([Figure: nXRi pumps](#) on page 8, (8)) to ON. Make sure that the power indicator LED ([Figure: Interface control panel](#) on page 9, (14)) illuminates. If the LED does not illuminate, contact us.
6. Press the start button ([Figure: Interface control panel](#) on page 9, (1)) until the run indicator LED ([Figure: Interface control panel](#) on page 9, (13)) begins to flash.
7. If the dry pumping system starts and continues to operate, continue at Step 8. If an alarm condition is indicated:
  - A. shut down the dry pumping system. Refer to [Shut down the pump](#) on page 29.
  - B. contact us.
8. After you commission the dry pumping system:
  - A. to continue to operate the system, refer to [Start the pump](#) on page 29.
  - B. to shut down the system, refer to [Shut down the pump](#) on page 29.

## 6. Operation

### 6.1 Operation safety



#### **WARNING: DAMAGED PARTS**

Risk of electric shock. Do not operate the pump with any parts of the enclosures removed or damaged as there may be a risk of an electric shock.



#### **WARNING: OPERATIONAL SAFETY**

Risk of injury or death of people. Do not expose any part of the human body to the vacuum as this could result in injury or death of people.



#### **WARNING: PUMP TEMPERATURE**

Risk of injury. Do not touch the pump inlet manifold or exhaust when the pump is running as the temperatures of these parts could be high. The pump will be warm for some time after the pump has stopped.



#### **CAUTION: AUTOMATIC START**

Risk of injury or damage to equipment. The system has an auto-run mode which, if configured, is designed to automatically start the pump system once power is applied.



#### **CAUTION: CONDENSATE DEPOSITION**

Risk of damage to equipment. Do not use the pump to pump particulates or condensate. Deposition may occur within the pump which can degrade the pump performance and reduce the pump life.

 **Note:**

*The control interface is determined by the interface that starts the pump. Once started, the pump can only be stopped by the interface that it was started from, except in auto-run mode. In auto-run mode, the stop button on the user interface panel will override the signal and stop the pump.*

 **Note:**

*This is an industrial (Class A, Group 1) product as defined by EN55011 and EN61326 in compliance with European Electromagnetic Compatibility (EMC) requirements for EMC emissions. "Group 1" is defined as equipment which does not use RF energy as an intrinsic part of operation or process.*

### 6.2 Operational modes

The pump can be controlled by:

- Manual control mode – with the buttons on the user interface panel.
- Parallel control mode – through the 15-way D-type logic interface connector located on the rear of the pump.
- Serial control mode – through the 15-way D-type logic interface connector located on the rear of the pump.
- Auto-run.

### 6.2.1 Manual control mode

Refer to [Figure: Interface control panel](#) on page 9 for the pump control functions.

**Table 11** Manual control mode

Operation	Button	Status
Apply power	Mains power	The pump will remain off (factory default). The power indicator will illuminate.
Start the pump	Start button	The pump will accelerate up to full running speed. The run indicator will flash while the pump accelerates. The run indicator will remain on when the pump reaches full speed.
Select and deselect the standby speed	Standby mode select button	When engaged, the standby indicator will illuminate and the pump will run at the standby speed setting. The pump is set by default at 70% of full speed.
Increase or decrease the pump speed when in standby mode	Standby speed increase button	The pump speed will increase. The increase standby indicator will remain illuminated when the pump reaches a maximum of 100% of full speed.
	Standby speed decrease button	The pump speed will decrease. The decrease standby indicator will remain illuminated when the pump reaches a minimum of 50% of full speed.
Select and deselect the Auto-run function	Start or stop button (>8 sec)	When engaged, the auto-run indicator will illuminate. The pump will restart automatically after the power has been restored.

#### Start and stop

Use the buttons ([Figure: Interface control pane](#) on page 9) to start and stop the pump.

 **Note:**

*The stop command does not isolate the pump from the electrical supply.*

#### Standby

In standby mode the pump operates at a reduced speed to improve the service life of the pump. The noise and power consumption decreases and the vacuum performance is reduced when the pump operates at standby speed.

1. Push the standby button to select standby mode. The pump will initially run at factory default standby speed (70% of full speed).
2. Adjust the speed with the increase and decrease standby speed buttons. The maximum standby speed is 100% of the default run speed and the minimum standby speed is 50% of the default run speed.

A single short push will change the speed by 1% of the default run speed. Hold the button to change the speed by 1% per second.

3. Once adjusted, the pump will return to the new user defined speed each time standby speed is selected.
4. Push the standby button to return to normal run speed.

**Table 12** LED indicators

LED	Description	Function
1	Power indicator	Indicates that electrical mains supply to the pump is ON.
2	Run indicator	Indicates that the pump is running.
3	Standby mode indicator	Indicates that the standby mode has been selected.
4	Standby speed increase indicator	The indicator will blink with every short push of the standby speed increase button. The indicator will remain ON when maximum standby speed has been reached.
5	Standby speed decrease indicator	The indicator will blink with every short push of the standby speed decrease button. The indicator will remain ON when minimum standby speed has been reached.
6	Auto-run indicator	Indicates that the auto-run mode has been selected.
7	Service indicator	Indicates that a service interval has been reached.
8	Alarm indicator	Indicates an alarm has been triggered.

### 6.3 Logic interface data

The pumps have a 15-way D-type logic interface connector located on the user interface panel (*Figure: nXRi pumps* on page 8, (6)). The logic interface connector can be plugged directly into the 200 W Turbo Instrument Controller (TIC) or turbo controller, or Turbo and Active Gauge controller (TAG). A suitable connector mating half must be used (not supplied) to connect the nXRi pump to the customer control system. Refer to and *Table: Logic interface pins* on page 25 for the electrical connections.

**Table 13** Interface technical data

Connector*	15-way D-type (male)
Start, serial enable and remote enable:	
<ul style="list-style-type: none"> <li>• Enable control voltage: low (closed)</li> <li>• Disable control voltage: high (open)</li> </ul>	<ul style="list-style-type: none"> <li>• 0 to 0.8 V d.c. (<math>I_{OUT} = 0.55</math> mA nominal)</li> <li>• 4 to 26.4 V d.c. (internal pull-up to a Thevenin equivalent circuit: 5.3 V and 11 kOhms nominal)</li> </ul>
Standby control input:	
<ul style="list-style-type: none"> <li>• Enable control voltage: low (closed)</li> <li>• Disable control voltage: high (open)</li> </ul>	<ul style="list-style-type: none"> <li>• 0 to 0.8 V d.c. (<math>I_{OUT} = 0.3</math> mA nominal)</li> <li>• 4 to 26.4 V d.c. (internal pull-up to a Thevenin equivalent circuit: 2.5 V and 10.3 kOhms nominal)</li> </ul>
Analogue and RS485 enable control inputs:	
<ul style="list-style-type: none"> <li>• Enable control voltage: low (closed)</li> <li>• Disable control voltage: high (open)</li> </ul>	<ul style="list-style-type: none"> <li>• 0 to 0.8 V d.c. (<math>I_{OUT} = 0.55</math> mA nominal)</li> <li>• 4 to 26.4 V d.c. (internal pull-up to a Thevenin equivalent circuit: 5.5 V and 11.4 kOhms nominal)</li> </ul>
Analogue speed input	0 to 10 V d.c. directly proportional to the motor speed e.g. 0 V = 0 Hz, 10 V = 250 Hz

Voltage accuracy	± 5% full scale
NORMAL status output:	
<ul style="list-style-type: none"> <li>• Type</li> <li>• &lt; Normal speed (default 80%)</li> <li>• &gt;Normal speed</li> <li>• Maximum current rating</li> <li>• Maximum voltage rating</li> </ul>	<ul style="list-style-type: none"> <li>• Open collector transistor plus pull up resistor</li> <li>• OFF (4.7 k pull up + diode to 12 V d.c.)</li> <li>• ON (&lt; 0.8 V d.c. sinking 10 mA)</li> <li>• 10 mA</li> <li>• 28.8 V d.c</li> </ul>
FAIL status output:	
<ul style="list-style-type: none"> <li>• Type</li> <li>• Fail</li> <li>• OK</li> <li>• Maximum current rating</li> <li>• Maximum voltage rating</li> </ul>	<ul style="list-style-type: none"> <li>• Open collector transistor plus pull up resistor</li> <li>• OFF (4.7 k pull up + diode to 12 V d.c.)</li> <li>• ON (&lt; 0.8 V d.c. sinking 10 mA)</li> <li>• 10 mA</li> <li>• 28.8 V d.c.</li> </ul>
Analogue 10 V reference	+ 10 V d.c. analogue voltage reference unipolar output with diode protection
Voltage accuracy output	± 2% full scale
Current	≤ 5 mA for specified accuracy

\* Mating half of connector not supplied

**Table 14** Logic interface pins

Pin number	Signal	Polarity	Use
1	Analogue speed enable-control input	-	Connect to pin 2 (0 V) to enable analogue speed control via pin 9.
2	0 V control reference	-	0 V reference for all control and status signals listed within this table.
3	Start/Stop – control input	-	Connect to pin 2 (0 V) to start the pump system.
4	Standby – control input/serial-RX/RS-485 A-	-	Connect to pin 2 (0 V) to enable standby speed when the serial enable control input is inactive.
5	Serial enable – control input	-	Connect to pin 2 (0 V) to enable serial communications.
6	RS-232/RS-485 – control input	-	Default configuration is RS-232 with pin 6 disconnected. Connect to pin 2 (0 V) to enable RS-485 serial communications.
7	Fail – status output/Serial-TX/RS-485 B+	-	Logic high when a fail/fault condition exists and the serial enable control input is inactive.
8	0 V control reference	-	0 V reference for all control and status signals listed within this table.
9	Analogue speed – control input	-	0-10 V analogue input: 0 V = 0% speed; +10 V = 100% speed
10	Chassis/Screen	-	Screen
11	+10 V analogue reference – Control output	Positive	+10 V analogue voltage reference output: 5 mA; unipolar output, diode protected.
12	Chassis/Screen	-	Screen
13	Not connected	-	Unused control pin
14	Remote – control input	-	Connect to pin 2 (0 V) to enable remote control via parallel or serial control modes.
15	Normal – status output	-	Logic low when the pump rotational speed is at normal speed or above.

## 6.4 Parallel control and monitoring



### CAUTION: EMF RISK

**Risk of damage to equipment. If you use the normal and fail lines to drive the coils of d.c. relays, include a back EMF suppression diode in parallel with each relay coil to protect the pump.**

Connect the control equipment to the control input pins of the logic interface mating half. Refer to [Table: Logic interface pins](#) on page 25 to identify the logic interface connector pins. The control inputs are:

- Start
  - Standby speed
  - Analogue speed
- A. To activate the control inputs, connect the relevant control input (pin 14) to the 0 V control reference.
  - B. The NORMAL output can go down up to 100 mA when you control an external relay coil with an external coil voltage of + 24 V d.c. The external + 24 V voltage source, must be referenced to the common control voltage of the pump control system, i.e. pin 2 of the 15-Way D-Type customer interface connector. Alternatively, if the NORMAL output is connected to + 10 V reference output of the control system, i.e. pin 11 of the 15-Way D-Type connector, a 4.7 kOhm pull-up resistor is recommended to be kept in the current rating of + 10 V reference rail.
  - C. The FAIL output can go down up to 100 mA when you control an external relay coil with an external coil voltage of + 24 V d.c. The external + 24 V voltage source, must be referenced to the common control voltage of the pump control system, i.e. pin 2 of the 15-Way D-Type customer interface connector. Alternatively, if the FAIL output is connected to + 10 V reference output of the control system, i.e. pin 11 of the 15-Way D-Type connector, a 4.7 kOhm pull-up resistor is recommended to be kept in the current rating of + 10 V reference rail.

**Figure 8** Logic interface connections - parallel control

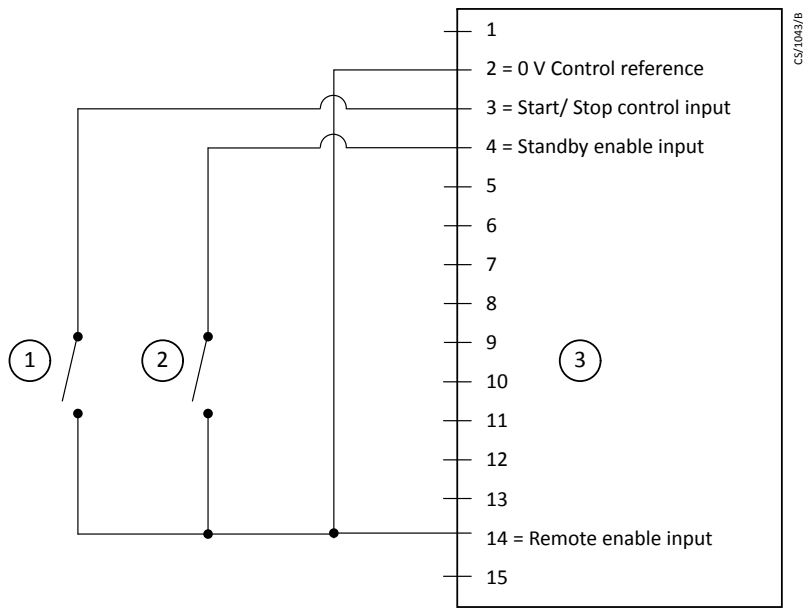

- 1. Start switch
- 2. Standby switch (optional)
- 3. nXRi pump logic interface

## 6.5 Analogue speed control

The analogue speed input is a process control source which enables the nXRi pump to run at variable operating speeds. This speed control source is an alternative to standby speed control.

**Figure 9** Logic interface connections - analogue speed control

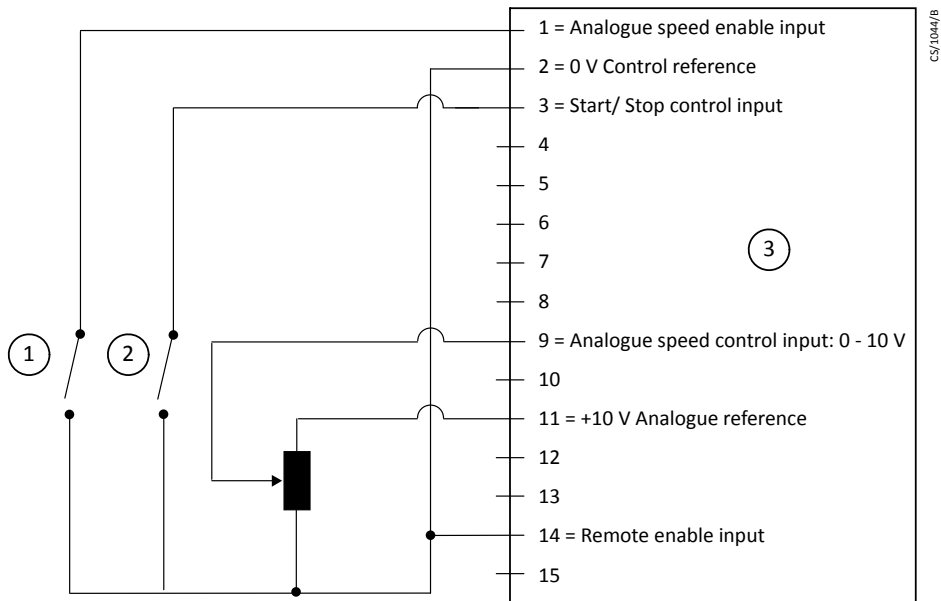

- 1. Start switch
- 2. Analogue control switch
- 3. nXRi pump logic interface

Figure 10 Analogue speed control

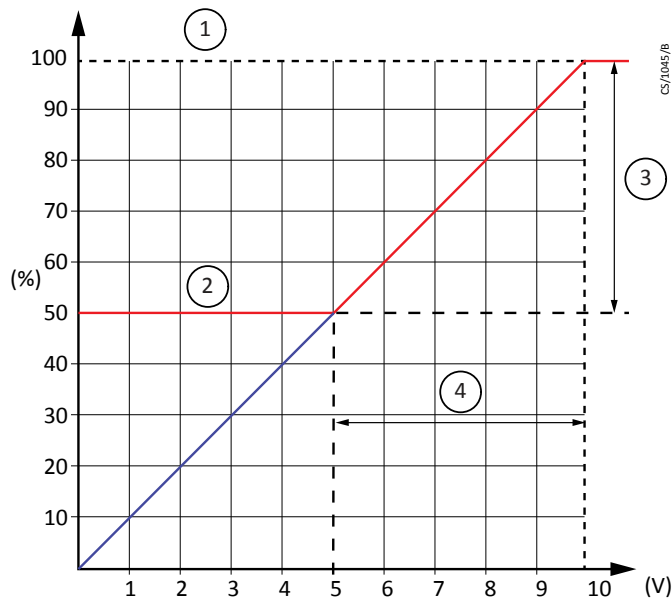

1. Upper speed clamp - Maximum standby setting = 250 Hz
2. Lower speed clamp - Minimum standby speed setting = 125 Hz
3. Active speed range - 50.00 % to 100.00 %
4. Active Voltage range - 5.00 V to 10.00 V (125Hz to 250 Hz)

**Note:**

*0.1 V = 1% of default run speed.*

*Voltages below 5 V will result in a clamped speed of 50% of full speed.*

## 6.6 Hardware configuration

Use the 15-way D-type connector ([Figure: nXRi pumps](#) on page 8, (6)) and configure the signal to enable the analogue speed control source:

- Connect the analogue speed enable control input (pin 1) to the 0 V control reference (pin 2).
- Connect a suitably calibrated analogue voltage source (0 to +10 V), for example, (DAC) to the analogue speed control input (pin 9).  
As an alternative, connect the output of a potentiometer referenced to the pump reference voltage (pin 11) to the analogue speed control input (pin 9). Refer to [Figure: Logic interface connections - analogue speed control](#) on page 27. The 0 V rail of the external voltage source must be connected to the 0 V control reference (pin 2) of the pump controller.

## 6.7 Operational modes

- A +10 V input results in a mechanical running speed which is equal to 100% of the default run speed, that is 250 Hz.
- The minimum running speed provided by the analogue speed control source, is clamped at the minimum standby speed setting (approximately 50% of the default run speed).



- The maximum running speed provided by the analogue speed control source is clamped by the maximum standby speed setting (100% of the default run speed).

## 6.8 Start the pump



### **WARNING: EXHAUST PIPELINE BLOCKAGE**

**Risk of damage to equipment. Do not operate the pump if the exhaust pipeline is restricted or blocked as the pump will not operate correctly and may be damaged.**

To start the pump:

1. Make sure that the vacuum system isolation valve is closed (if fitted).
2. Make sure that the mains supply to the pump is isolated.
3. Connect a recommended lead to the electrical socket on the pump. Refer to [Figure: nXRi pumps](#) on page 8.
4. Supply the power.
5. Start the pump with the applicable control source that follows:
  - use the start button in manual control mode, refer to [Figure: Interface control panel](#) on page 9
  - use the start/stop control input in parallel control mode
  - use start command in serial control mode
6. Open the vacuum system isolation valve, if installed.

## 6.9 Shut down the pump



### **CAUTION: PUMP SUPPLY ISOLATION**

**Risk of injury. Do not remove the inlet connections until the pump has been allowed to stop rotating and the power and gas supply has been isolated. The pump can take upto three minutes to stop completely.**



### **WARNING: ELECTRICAL SUPPLY**

**Risk of damage to equipment. Do not disconnect the pump from the electrical supply until the pump has stopped completely.**

The pump can be shut down with either the front panel controls or the 15-way D-type connector in either parallel or serial control mode.

#### **Note:**

*If the pump is to be shut down for storage, remove any process gases by running on a gas ballast for at least one hour.*

To shut down the pump:

1. Close the vacuum system isolation valves to prevent suck-back into the vacuum system (where fitted).
2. Stop the pump system with the appropriate control source.

- use the stop button in manual control mode, refer to [Figure: Interface control panel](#) on page 9.
  - use the start/stop control input in parallel control mode.
  - use stop command in serial control mode.
3. Isolate the mains supply.

If the pump is to be stored, we recommend you either keep the pump under vacuum or fill the pump with dry nitrogen to prevent condensation in the pump. To keep the pump under vacuum, we recommend you seal the inlet and run the pump for at least 20 seconds.

## 6.10 Restart the pump

If the pump is automatically shut down because of an alarm condition, correct the alarm condition before you start the pump. To restart the pump, refer to [Start the pump](#) on page 29.

## 7. Maintenance and service

### 7.1 General maintenance

The system requires no user maintenance. Maintenance must be done by trained personnel. The frequency of the maintenance depends on the process and can be adjusted according to the user experience. Refer to [Maintenance plan](#) on page 31 for the maintenance schedule.

We recommend a monthly visual inspection of the dry pump system. Check that the electrical supply cord, hoses and pipelines connected to the pump are in good condition and are secured properly.

### 7.2 Maintenance plan

More frequent maintenance may be required if the pump is used to pump aggressive gases or vapours, solvents, organic substances and acids, or if the pump is operated continuously at high operating temperature.

**Table 15** Maintenance plan

Operation	Frequency (months)	Service indicator	Reference
Inspect and clean the inlet strainer	12	No	<a href="#">Inspect and clean the inlet strainer</a> on page 31
Inspect and clean the external fan cover if required	12	No	<a href="#">Clean the external fan grill</a> on page 32
Replace the pump bearings	60	Yes	<a href="#">Replace the pump bearings</a> on page 32
Replace the pump controller	120	Yes	<a href="#">Replace the pump controller</a> on page 32
Electrical safety check	60	No	<a href="#">Electrical safety check</a> on page 32

 **Note:**

*The pump must be returned to the Service Technology Centre for maintenance. For service indicator codes, refer to [Table: Service indicator codes](#) on page 32.*

### 7.3 Inspect and clean the inlet strainer

Whenever the pump is disconnected from the vacuum system or annually:

- Remove the inlet strainer from the pump inlet, refer to [Figure: nXRi pumps](#) on page 8.
- Clean the pump inlet and remove the debris that may have accumulated.
- Examine the inlet strainer and if necessary, clean it with a cleaning solution suitable for the substances pumped.
- Install the inlet strainer before you reconnect the pump to the vacuum system. Refer to [Mechanical installation](#) on page 16.

## 7.4 Clean the external fan grill

If the fan cover is not kept clean, the air flow over the pump can be restricted and the pump may overheat.

To clean the fan grill:

1. Switch off the pump and disconnect from the electrical supply.
2. Use a dry cloth and a soft brush to remove dirt and deposits on the fan cover.

## 7.5 Replace the pump bearings

The service indicator, (flashing ON 3 sec/OFF 1 sec) is activated to indicate that a bearing replacement service interval has been reached. Bearing wear cannot always be detected under normal operating conditions. This service interval is a recommendation that a bearing replacement is required and is useful in the preventative maintenance plan.

 **Note:**

*Failure to replace the pump bearings on time can damage the pumping mechanism.*

To reset the service indicator, refer to [Table: Service indicator codes](#) on page 32.

Bearing replacement is not possible by the customer, the pump must be returned to a Service Technology Centre for maintenance.

## 7.6 Replace the pump controller

The service indicator, (flashing ON 3s / OFF 3s) is activated to indicate that the pump controller must be replaced. Contact us for further details.

To reset the service indicator, refer to [Table: Service indicator codes](#) on page 32.

Controller replacement is not possible by the customer, the pump must be returned to a Service Technology Centre for maintenance.

## 7.7 Electrical safety check

Test the earth continuity and the insulation resistance of the pump system in accordance with local regulations for the periodic test of electrical equipment.

The earth continuity must be less than 0.1  $\Omega$  and the DC insulation resistance greater than 1.0 MEG  $\Omega$ . If the pump fails any of these tests, contact us or the supplier.

## 7.8 Service indicator codes

The nXRi controller has a service indicator, refer to [Figure: Interface control panel](#) on page 9. The service indicator will flash a specific code whenever a service interval is reached. See [Table: Service indicator codes](#) on page 32 for service levels.

**Table 16** Service indicator codes

Service flash code	Comments
ON 3s/OFF 1s	Pump bearing service
ON 3s/OFF 3s	Pump controller service

## 7.9 Service

It is recommended that the pump should be serviced every 5 years. The pump should then be returned to an Edwards Service Technology Centre.

Our products are supported by a world-wide network of Service Technology Centres offering a wide range of options including:

- Complete remanufacturing (includes 6 months warranty)
- Exchange pump (includes 12 months warranty)

Both services include decontamination, repair, rebuild and test to factory specification.

A local Service Technology Centre can also provide trained engineers to support the exchange pump option. For more information about service options, contact us or the nearest Service Centre.

### 7.9.1 Return the equipment or components for service

Before you send your equipment to us for service or for any other reason, you must send us a completed Declaration of Contamination of Vacuum Equipment and Components – Form HS2. The HS2 form tells us if any substances found in the equipment are hazardous, which is important for the safety of our employees and all other people involved in the service of your equipment. The hazard information also lets us select the correct procedures to service your equipment.

We provide instructions for completing the form in the Declaration of Contamination of Vacuum equipment and Components – Procedure HS1.

If you are returning a vacuum pump, note the following:

- If a pump is configured to suit the application, make a record of the configuration before returning the pump. All replacement pumps will be supplied with default factory settings.
- Do not return a pump with accessories fitted. Remove all accessories and retain them for future use.
- The instruction in the returns procedure to drain all fluids does not apply to the lubricant in pump oil reservoirs.

Download the latest documents from [www.edwardsvacuum.com/HSForms/](http://www.edwardsvacuum.com/HSForms/), follow the procedure in HS1, fill in the electronic HS2 form, print it, sign it, and return the signed copy to us.



#### **NOTICE:**

**If we do not receive a completed HS2 form, your equipment cannot be serviced.**

## 8. Fault finding

A list of fault conditions and their possible causes is provided to assist in basic troubleshooting. If you are not able to rectify a fault, call your supplier or your nearest Edwards Service Centre for advice.

<b>Fault</b>	<b>The pump has failed to start or has stopped</b>
<b>Cause</b>	<b>The electrical supply fuse has blown.</b>
<b>Remedy</b>	<p>Make sure that the external electrical supply is switched on and that the power indicator LED (<i>Figure: Interface control panel</i> on page 9, (14)) is illuminated.</p> <p>If the LED does not illuminate, contact us.</p>
<b>Cause</b>	<b>The motor controller has not reset after an over temperature event.</b>
<b>Remedy</b>	<p>Disconnect the main power supply and wait for at least one minute and attempt to restart the pump. If the pump still does not start, contact us.</p> <p>If the alarm indicator LED (<i>Figure: Interface control panel</i> on page 9, (5)) flashes, it indicates that the pump has high current load from possibly a high inlet pressure/flow. Adjust the inlet pressure/flow until the pump performance recovers.</p>
<b>Fault</b>	<b>The pump has failed to achieve the required performance</b>
<b>Cause</b>	<b>The pressure measurement technique or gauge head is not suitable or gives an incorrect indication of pressure.</b>
<b>Remedy</b>	Make sure that the vacuum measurement equipment is calibrated and is updated. The correct gauge range must be selected for the application. Contact us for further assistance on gauge selection, if required.
<b>Cause</b>	<b>The vacuum fittings are dirty or damaged.</b>
<b>Remedy</b>	Make sure that the vacuum fittings are clean and scratch free.
<b>Cause</b>	<b>There is a blockage or high pressure in the exhaust line.</b>
<b>Remedy</b>	Make sure that the exhaust valves fitted are not closed when the pump is in operation.
<b>Cause</b>	<b>The motor controller is current limiting the supply.</b>
<b>Remedy</b>	If the alarm indicator LED ( <i>Figure: Interface control panel</i> on page 9, (5)) flashes, it indicates that the pump has high current load from possibly a high inlet pressure/flow. Adjust the inlet pressure/flow until the pump performance recovers.
<b>Cause</b>	<b>The pump performance is different at the working application load.</b>
<b>Remedy</b>	The pump does not have a flat performance curve, peak pumping speed can vary with inlet pressure and gas load. Check the actual performance against the performance curve shown in <i>Technical data</i> on page 12.
<b>Fault</b>	<b>The pump is noisy</b>
<b>Cause</b>	<b>The pump is contaminated with solid particles.</b>

Remedy Contact us or the supplier for further information.

**Fault** The pumping speed is poor or pump down time is too long

**Cause** The pipelines connections are too small in diameter.

Remedy Make sure that the pipework has sufficient conductance (user's responsibility) and the pump performance is not compromised.

**Cause** There is a leak in the system.

Remedy Do the leak test of the pump system in accordance with the requirements specified in [Table: Performance data](#) on page 13.

**Cause** The motor controller is current limiting the supply.

Remedy Adjust the inlet pressure/flow until the pump performance recovers.

**Cause** The pump chamber is too big.

Remedy Make sure that the chamber size does not exceed the limits specified in [Table: Mechanical data](#) on page 12.

## 8.1 Alarm indicator codes

When the fail condition becomes active, the red alarm indicator shows a flashing sequence.

- If the error light is on continuously, this indicates a problem has been found with the embedded software. In this case, switch the power supply on and off.
- If the indication is not cleared, a software download may be required. In this case, contact us or the supplier.
- If the alarm indicator is flashing, identify the error flash code. Refer to [Table: Flashing error codes](#) on page 35.

 **Note:**

*There is a sufficient off period between each subsequent cycle repetition to mark the start of a new flash sequence. The duration of a long flash (L) is equal to 3 times the duration of a short flash (0.5 s).*

**Table 17** Flashing error codes

Error flash position	Error flash sequence	Comment	Actions
0	s-s-s-s-s	Overload timeout	Check if the pump is not under constant high pressure or the inlet or outlet is not blocked.
1	L-s-s-s-s	Controller software error	Switch the power to the pump off and on and see whether the error code appears again. If it does, contact us or the supplier.
2	s-L-s-s-s	Controller failed internal configuration and calibration operation	Switch the power to the pump off and on and see whether the error code appears again. If it does, contact us or the supplier.
3	s-s-L-s-s	Acceleration timeout	Check if the pump is under constant high pressure or the inlet or outlet is blocked.

A90301880\_B - Fault finding

Error flash position	Error flash sequence	Comment	Actions
4	s-s-s-L-s-s	Over-current trip activated, or other hardware fault	Switch power to the pump off and on and see whether the error code appears again. If it does, contact us or the supplier.
5	s-s-s-s-L-s	Self test fault	Switch the power to the pump off and on and see whether the error code appears again. If it does, contact us or the supplier.
6	s-s-s-s-s-L	Serial control mode interlock	Re-activate the serial enable and send a serial command to clear the error code.



## 9. Storage



### **WARNING: HAZARDOUS SUBSTANCES**

Do not drain oil from the pump. Install the blanking plates to seal the vacuum inlet and outlet ports to prevent the possible oil leakage. Make sure that the pump is correctly labelled. If in doubt, contact us.



### **WARNING: INHALATION HAZARD**

Risk of asphyxiation. Do not burn the fluoroelastomer seals, tip seal material and O-rings.

To store the pump:

1. Shut down the pump. Refer to [Shut down the pump](#) on page 29.
2. Disconnect the pump from the electrical supply.
3. Place and secure protective covers over the inlet and outlet ports.
4. Store the pump in a clean and dry condition until required for use.
5. When necessary, prepare and install the pump. Refer to [Installation](#) on page 15.

## 10. Disposal



### **WARNING: CONTAMINATION HAZARD**

**Risk of toxic exposure and acid burns. Identify, contain and safely dispose of contaminated items.**

Dispose of the pump and any components or accessories safely and in accordance with all local and national safety and environmental requirements.

Our products are supported by a world-wide network of Service Centres. Each Service Centre offers a wide range of options including disposal. Refer to [Service](#) on page 33 for more information.

Dry pump system materials suitable for recycling include cast iron, steel, PTFE, stainless steel, aluminium, zinc alloy, nickel, mild steel, ABS and polyamide.

Take particular care with:

- Fluoroelastomers which may have decomposed as the result of being subjected to high temperatures.
- Components which have been contaminated with dangerous process substances.

## 11. Accessories

Contact us for information on the available accessories to support your pump.

**Table 18** Accessories

S. no.	Description	S. no.	Description
1	Cord sets	5	Inlet valve - switched by pump
2	Communication cables (USB)	6	Fixing kits
3	Control software	7	Gas ballast blank
4	Electromagnetic valve for gas ballast	8	Gas ballast purge adapter

### 11.1 Electrical cables

**Table 19** Recommended cord sets

Description	Rating	Coupler type	Item number
Cord set assembly, UK	H05VV-F, 3 x 1.5 mm <sup>2</sup> , 300 V, 70 °C fitted with a BS1363 UK plug with BS1362 13 A fuse to an IEC60320 style C19 with a maximum length of 2.5 m	Straight entry	A50505003
		Right-angled entry	A50505006
Cord set assembly, Europe	H05VV-F, 3 x 1.5 mm <sup>2</sup> , 300 V, 70 °C fitted with a European Schuko VDE approved 16 A 250 V rated plug with dual earthing contact to an IEC60320 style C19 with a maximum length of 2.5 m	Straight entry	A50506003
		Right-angled entry	A50506006
Cord set assembly, USA/Canada (200-240 V)	SJT, 3 x 14 AWG, 300 V, 90 °C, VW-1 fitted with a NEMA 6-15P plug and IEC 60320 C19 coupler with a maximum length of 2 m	Straight entry	A50507006

