



Edwards XDS-100B

Technical Specifications

General	XDS100B
Nominal peak pumping speed	95 m ³ /h*
Maximum permitted continuous inlet pressure	20 mbar
Maximum permitted continuous exhaust pressure	60 mbar
Maximum permitted inlet pressure for short duration	1.5 bar(a)
Maximum chamber volume to pump down from atmospheric pressure	100 litres
Maximum chamber volume for cyclic duty - maximum 6 cycles per hour	50 litres
Suckback protection	Provided by backing pump
Leak tightness	<1x10 ⁻⁶ mbar l s ⁻¹

* XDS100B used in combination with XDS35i backing pump.

Parameter	XDS100B
Overall dimensions (L x W x H)	476 x 333 x 396 mm
Maximum tilt angle	10 degrees
Nominal rotational speed	1750 rpm
Mass	48 kg
Inlet connection	NW40
Outlet connection	NW40
Degree of protection (IEC60529)	IP44

Pump	Supply (V)	Phase	Frequency (Hz)	Current (A)
XDS100B	200/230	Single	50/60	6.6
	100/120	Single	50/60	10.6





PROVAC

SALES

PHONE: 831-462-8900

FAX: 831-462-3536

WWW.PROVAC.COM

Edwards XDS-100B Pumping Curves

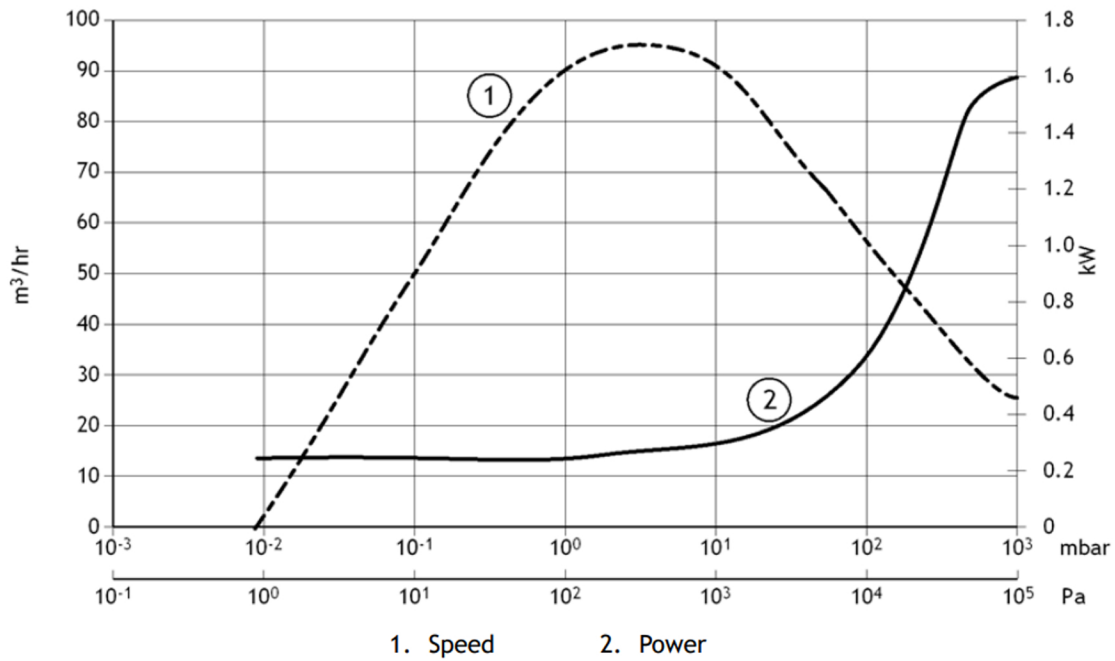

Dimensions

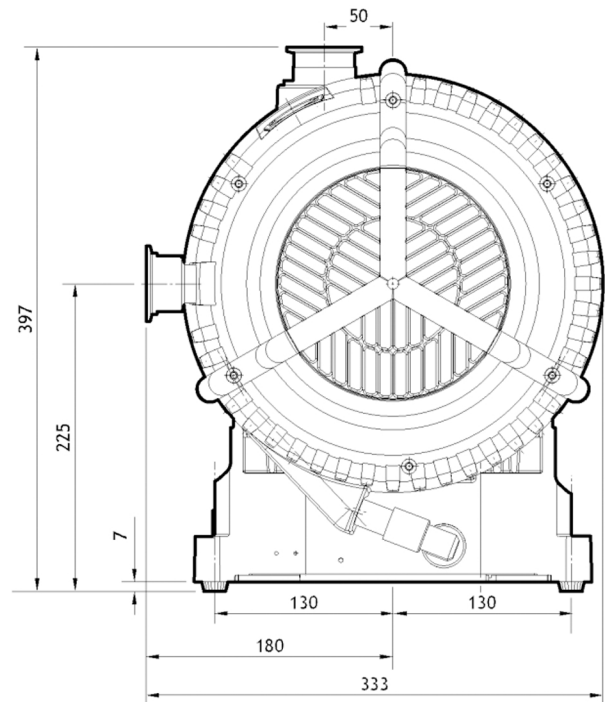
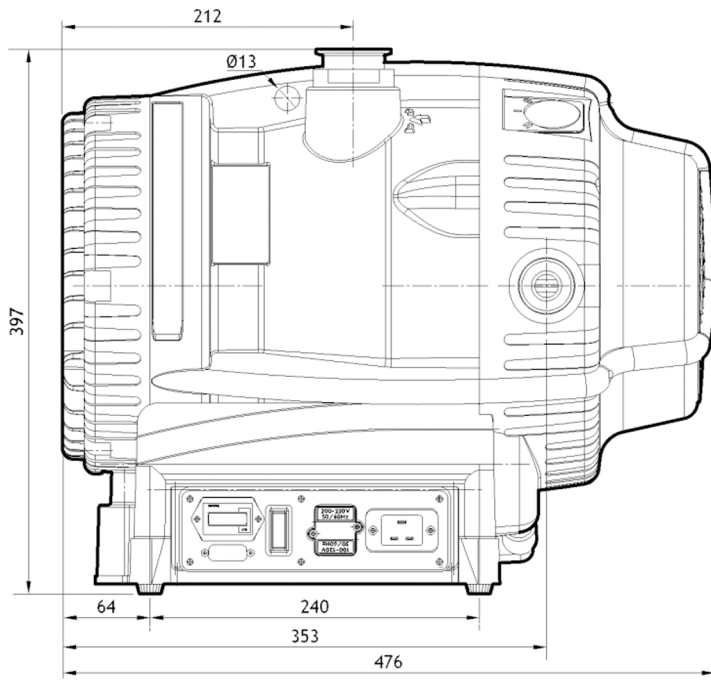



PROVAC

SALES

PHONE: 831-462-8900

FAX: 831-462-3536

WWW.PROVAC.COM

Edwards XDS-100B

Features & Benefits

- intended for use in conjunction with XDS-35i & XDS-46i
- suitable for use on vapour handling processes
- innovative bearing shield design isolates the vacuum environment from all forms of lubricant
- motor is controlled by an inverter that manages the supply of current to the motor in accordance with operating conditions
- low cost of ownership & maximum uptime

Applications

- booster for XDS-35i & XDS-46i

