

Turbo-V 70 Controller

**Model 969-9405
Model 969-9505**

MANUALE ISTRUZIONI

BEDIENUNGSHANDBUCH

NOTICE DE MODE D'EMPLOI

MANUAL DE INSTRUCCIONES

MANUAL DE INSTRUÇÕES

BEDRIJFSHANDLEIDING

ISTRUKSTIONSBOG

BRUKSANVISNING

INSTRUKSJON MANUAL

OHJEKÄSIKIRJA

ΟΔΗΓΙΕΣ ΧΡΗΣΕΩΣ

INSTRUCTION MANUAL

Turbo-V 70 Controller



VARIAN



vacuum technologies

Dear Customer,

Thank you for purchasing a VARIAN vacuum product. At VARIAN Vacuum Technologies we make every effort to ensure that you will be satisfied with the product and/or service you have purchased.

As part of our Continuous Improvement effort, we ask that you report to us any problem you may have had with the purchase or operation of our product. On the back side you find a Corrective Action Request form that you may fill out in the first part and return to us.

This form is intended to supplement normal lines of communications and to resolve problems that existing systems are not addressing in an adequate or timely manner.

Upon receipt of your Corrective Action Request we will determine the Root Cause of the problem and take the necessary actions to eliminate it. You will be contacted by one of our employees who will review the problem with you and update you, with the second part of the same form, on our actions.

Your business is very important to us. Please, take the time and let us know how we can improve.

Sincerely,

Sergio PIRAS

*Vice President and General Manager
VARIAN Vacuum Technologies*

Note: Fax or mail the Customer Request for Action (see backside page) to VARIAN Vacuum Technologies (Torino) - Quality Assurance or to your nearest VARIAN representative for onward transmission to the same address.

CUSTOMER REQUEST FOR CORRECTIVE / PREVENTIVE / IMPROVEMENT ACTION

TO : VARIAN VACUUM TECHNOLOGIES TORINO - QUALITY ASSURANCE

FAX N° : XXXX - 011 - 9979350

ADDRESS: VARIAN S.p.A. - Via F.lli Varian, 54 - 10040 Leinì (Torino) - Italy

E-MAIL : marco.marzio@varianinc.com

NAME _____	COMPANY _____	FUNCTION _____
<p>ADDRESS : _____</p> <p>TEL. N° : _____ FAX N° : _____</p> <p>E-MAIL : _____</p>		
<p>PROBLEM / SUGGESTION :</p> <p>_____</p> <p>_____</p> <p>_____</p> <p>_____</p>		
<p>REFERENCE INFORMATION (model n°, serial n°, ordering information, time to failure after installation, etc.) :</p> <p>_____</p> <p>_____</p> <p>_____</p> <p style="text-align: right;">DATE _____</p>		

<p>CORRECTIVE ACTION PLAN / ACTUATION (by VARIAN VTT)</p> <p>_____</p> <p>_____</p> <p>_____</p> <p>_____</p> <p>_____</p>	<p>LOG N° _____</p>
--	---------------------

XXXX = Code for dialing Italy from your country (es. 01139 from USA; 00139 from Japan, etc.)



ISTRUZIONI PER L'USO	1
GEBRAUCHSANLEITUNG	5
MODE D'EMPLOI.....	9
ISTRUCCIONES DE USO	13
ISTRUÇÕES PARA O USO	17
GEBRUIKSAANWIJZINGEN.....	21
BRUGSANVISNING.....	25
BRUKSANVISNING	29
BRUKERVEILEDNING.....	33
KÄYTTÖOHJEET	37
ΟΔΗΓΙΕΣ ΧΡΗΣΕΩΣ.....	41
INSTRUCTIONS FOR USE	45
TECHNICAL INFORMATION	49
TURBO-V 70 CONTROLLER DESCRIPTION	49
CONTROLLER SPECIFICATIONS	50
CONTROLLER OUTLINE	50
Line Voltage Change Over	51
POWER INTERCONNECTIONS	51
Connection J7 - 120 Vac Connector	51
Connection P6 - 24 Vdc Connector.....	52
LOGIC INTERCONNECTIONS.....	52
Connection P1 - Logic Input Interconnections.....	52
Connection J2 - Logic Output Interconnections	53
Controller-to-Pump Connection.....	54
RS 232 OPTION.....	54
RS 232 Installation	54
RS 232 Communication Port.....	54
RS 232 Communication Descriptions	55

USE	57
General.....	57
Startup.....	57
FRONT / REMOTE / 232 Selection.....	58
Monitor Relay Programming.....	60
Reset Command	62
Starting the Pump.....	62
Operating the Pump	63
Low Speed Operation.....	63
Pump Shutdown	64
Power Failure	64
Remote Control Mode Operation	65
RS 232 Control Mode Operation	65
ERROR MESSAGES.....	66
CONTROLLER TEST.....	67
Power Supply Test	67
Test with Dummy Load.....	68
Pump over-Temperature Test.....	68
Functional Test.....	68
ACCESSORIES AND SPARE PARTS	69
OPTIONS	69

INFORMAZIONI GENERALI

Questa apparecchiatura è destinata ad uso professionale. L'utilizzatore deve leggere attentamente il presente manuale di istruzioni ed ogni altra informazione addizionale fornita dalla Varian prima dell'utilizzo dell'apparecchiatura. La Varian si ritiene sollevata da eventuali responsabilità dovute all'inosservanza totale o parziale delle istruzioni, ad uso improprio da parte di personale non addestrato, ad interventi non autorizzati o ad uso contrario alle normative nazionali specifiche. I controller della serie Turbo-V 70 sono dei convertitori di frequenza, controllati da un microprocessore, realizzati con componenti a stato solido e con capacità di autodiagnostica e autoprotezione.

I controller pilotano le pompe della serie Turbo-V 70 (con un processo suddiviso in dieci passi) durante la fase di avvio controllando la tensione e la corrente in rapporto alla velocità raggiunta dalla pompa. Essi incorporano tutta la circuiteria necessaria per il funzionamento automatico delle pompe della serie Turbo-V 70.

Tramite un connettore ausiliario sono disponibili i comandi per l'avvio e l'arresto della pompa da remoto, i segnali che indicano lo stato operativo della pompa, i comandi per l'avvio e l'arresto della pompa di pre-vuoto, segnali di bloccaggio (per interruttori a pressione, interruttori di controllo del flusso dell'acqua, ecc.)

Nei paragrafi seguenti sono riportate tutte le informazioni necessarie a garantire la sicurezza dell'operatore durante l'utilizzo dell'apparecchiatura. Informazioni dettagliate sono fornite nell'appendice "Technical Information".

Questo manuale utilizza le seguenti convenzioni:



PERICOLO!

I messaggi di pericolo attirano l'attenzione dell'operatore su una procedura o una pratica specifica che, se non eseguita in modo corretto, potrebbe provocare gravi lesioni personali.



ATTENZIONE

I messaggi di attenzione sono visualizzati prima di procedure che, se non osservate, potrebbero causare danni all'apparecchiatura.

NOTA

Le note contengono informazioni importanti estrapolate dal testo.

IMMAGAZZINAMENTO

Durante il trasporto e l'immagazzinamento dei controller devono essere soddisfatte le seguenti condizioni ambientali:

- temperatura: da -20 °C a +70 °C
- umidità relativa: 0 - 95% (non condensante)

PREPARAZIONE PER L'INSTALLAZIONE

Il controller viene fornito in un imballo protettivo speciale; se si presentano segni di danni, che potrebbero essersi verificati durante il trasporto, contattare l'ufficio vendite locale.

Durante l'operazione di disimballaggio, prestare particolare attenzione a non lasciar cadere il controller e a non sottoporlo ad urti.

Non disperdere l'imballo nell'ambiente. Il materiale è completamente riciclabile e risponde alla direttiva CEE 85/399 per la tutela dell'ambiente.

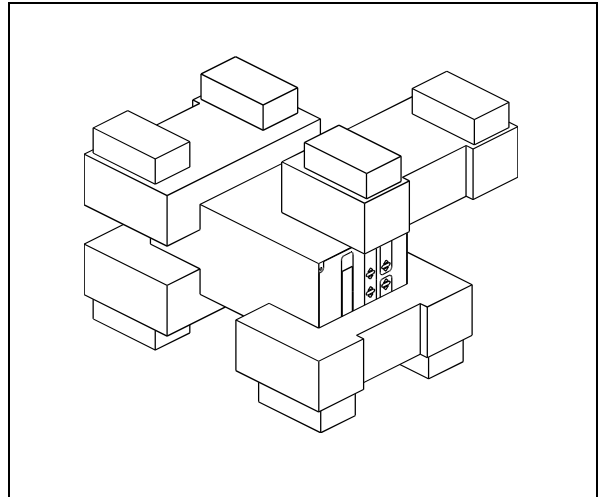

*Imballo dei controller
969-9405 e 969-9505*

Ogni controller giunge dalla Varian predisposto per una certa tensione di alimentazione:

- il modello 969-9405 per 220 Vac
- il modello 969-9505 per 120 Vac

Nel caso in cui fosse necessario cambiare la tensione di alimentazione, procedere come segue:

- Scollegare il cavo di alimentazione dal pannello posteriore del controller.
- Verificare sul modulo di ingresso tensione la tensione di alimentazione predisposta.
- Estrarre il modulo di selezione tensione con fusibile tramite un piccolo cacciavite.
- Selezionare la tensione di alimentazione desiderata e quindi reinserire con decisione il modulo nel suo vano.
- Verificare che sia stata selezionata la tensione corretta e quindi ricollegare il cavo di alimentazione.

INSTALLAZIONE



PERICOLO!

Il controller è fornito di un cavo di alimentazione a tre fili con una spina di tipo approvato a livello internazionale. Utilizzare sempre questo cavo di alimentazione ed inserire la spina in una presa con un adeguato collegamento di massa onde evitare scariche elettriche.

All'interno del controller si sviluppano alte tensioni che possono recare gravi danni o la morte. Prima di eseguire qualsiasi operazione di installazione o manutenzione del controller scollegarlo dalla presa di alimentazione.

NOTA

Il controller può essere installato su di un tavolo o all'interno di un apposito rack. In ogni caso occorre che l'aria di raffreddamento possa circolare liberamente intorno all'apparato. Non installare e/o utilizzare il controller in ambienti esposti ad agenti atmosferici (pioggia, gelo, neve), polveri, gas aggressivi, in ambienti esplosivi o con elevato rischio di incendio.

Durante il funzionamento è necessario che siano rispettate le seguenti condizioni ambientali:

- temperatura: da 0 °C a +40 °C
- umidità relativa: 0 - 95% (non condensante).

Per il collegamento del controller con la relativa pompa utilizzare il cavo specifico del controller stesso.

NOTA

I controller modello 969-9405 e 969-9505 hanno il cavo di collegamento alla pompa fissato al pannello posteriore del controller stesso.

Per gli altri collegamenti e l'installazione degli accessori opzionali, vedere la sezione "Technical Information".

USO

In questo paragrafo sono riportate le principali procedure operative. Per ulteriori dettagli e per procedure che coinvolgono collegamenti o particolari opzionali, fare riferimento al paragrafo "Use" dell'appendice "Technical Information".

Prima di usare il controller effettuare tutti i collegamenti elettrici e pneumatici e fare riferimento al manuale della pompa collegata.



PERICOLO!

Per evitare danni alle persone ed all'apparato, nel caso in cui la pompa sia appoggiata su di un tavolo assicurarsi che sia stabile. Non far funzionare mai la pompa se la flangia di ingresso non è collegata al sistema o non è chiusa con la flangia di chiusura.

NOTA

Il connettore di richiusura J1 deve essere lasciato collegato con il suo ponticello se non viene effettuato alcun collegamento esterno. La pompa di pre-vuoto e la pompa Turbo-V possono essere accese contemporaneamente.

Comandi, indicatori e connettori del Controller

Di seguito sono illustrati il pannello di comando del Controller ed i pannelli di interconnessione.

Per maggiori dettagli fare riferimento alla sezione "Technical Information".

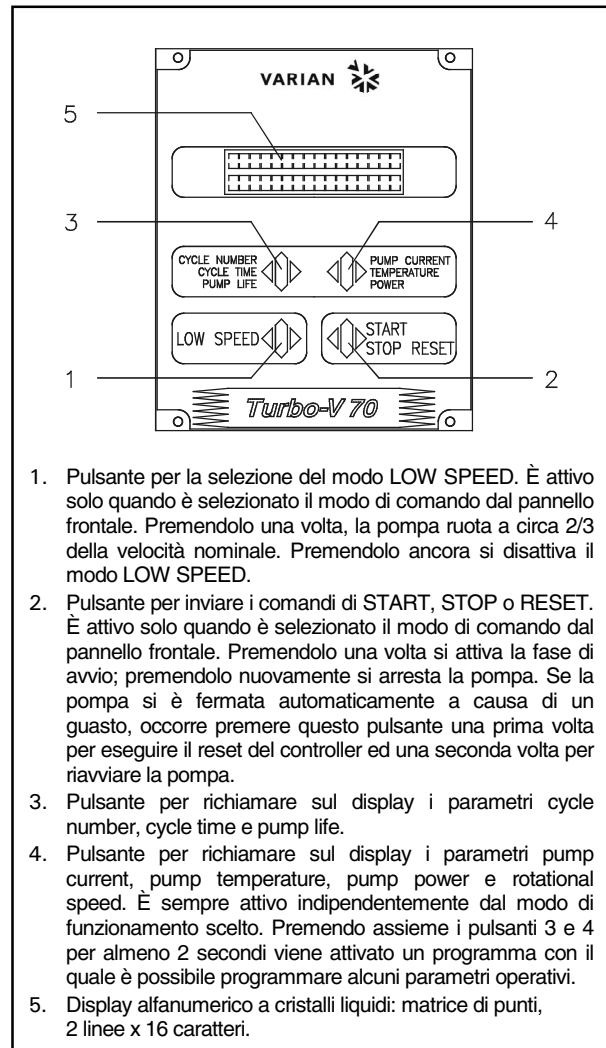

1. Pulsante per la selezione del modo LOW SPEED. È attivo solo quando è selezionato il modo di comando dal pannello frontale. Premendolo una volta, la pompa ruota a circa 2/3 della velocità nominale. Premendolo ancora si disattiva il modo LOW SPEED.
2. Pulsante per inviare i comandi di START, STOP o RESET. È attivo solo quando è selezionato il modo di comando dal pannello frontale. Premendolo una volta si attiva la fase di avvio; premendolo nuovamente si arresta la pompa. Se la pompa si è fermata automaticamente a causa di un guasto, occorre premere questo pulsante una prima volta per eseguire il reset del controller ed una seconda volta per riavviare la pompa.
3. Pulsante per richiamare sul display i parametri cycle number, cycle time e pump life.
4. Pulsante per richiamare sul display i parametri pump current, pump temperature, pump power e rotational speed. È sempre attivo indipendentemente dal modo di funzionamento scelto. Premendo assieme i pulsanti 3 e 4 per almeno 2 secondi viene attivato un programma con il quale è possibile programmare alcuni parametri operativi.
5. Display alfanumerico a cristalli liquidi: matrice di punti, 2 linee x 16 caratteri.

Pannello frontale del Controller
969-9405 e 969-9505

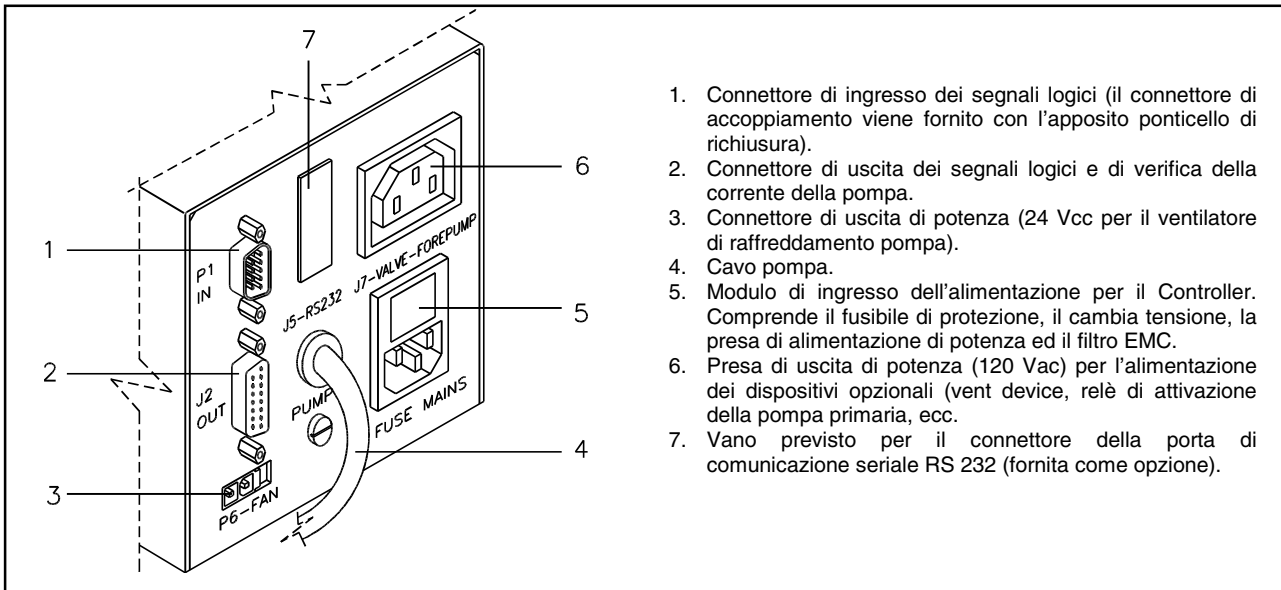

1. Connettore di ingresso dei segnali logici (il connettore di accoppiamento viene fornito con l'apposito ponticello di richiusura).
2. Connettore di uscita dei segnali logici e di verifica della corrente della pompa.
3. Connettore di uscita di potenza (24 Vcc per il ventilatore di raffreddamento pompa).
4. Cavo pompa.
5. Modulo di ingresso dell'alimentazione per il Controller. Comprende il fusibile di protezione, il cambia tensione, la presa di alimentazione di potenza ed il filtro EMC.
6. Presa di uscita di potenza (120 Vac) per l'alimentazione dei dispositivi opzionali (vent device, relè di attivazione della pompa primaria, ecc).
7. Vano previsto per il connettore della porta di comunicazione seriale RS 232 (fornita come opzione).

Pannello posteriore dei Controller 969-9405 e 969-9505

PROCEDURE DI USO

Accensione del Controller

Per accendere il controller è sufficiente inserire il cavo di alimentazione nella presa di rete.

Avvio della Pompa

Per avviare la pompa occorre premere il pulsante START del pannello frontale.

Arresto della Pompa

Per arrestare la pompa occorre premere il pulsante STOP del pannello frontale.

MANUTENZIONE

I controller della serie Turbo-V 70 non richiedono alcuna manutenzione. Qualsiasi intervento deve essere eseguito da personale autorizzato.

In caso di guasto è possibile usufruire del servizio di riparazione Varian o del "Varian advance exchange service", che permette di ottenere un controller rigenerato in sostituzione di quello guasto.

Qualora un controller dovesse essere rottamato, procedere alla sua eliminazione nel rispetto delle normative nazionali specifiche.



PERICOLO!

Prima di effettuare qualsiasi intervento sul controller scollegare il cavo di alimentazione.

MESSAGGI DI ERRORE

In alcuni casi di guasto la circuiteria di autodiagnosi del controller presenta alcuni messaggi di errore elencati nella tabella seguente.

MESSAGGIO	DESCRIZIONE	AZIONE CORRETTIVA
CHECK CONNECTION TO PUMP	Malfunzionamento nel collegamento tra pompa e controller.	Verificare che il cavo di collegamento tra pompa e controller sia ben fissato da entrambe le estremità e non sia interrotto. Premere due volte il pulsante START per riavviare la pompa.
PUMP WAITING INTERLOCK	È attivo il segnale di interlock presente sul connettore P1 a causa dell'interruzione del corto circuito tra il pin 3 ed il pin 8 del connettore J1, o a causa dell'apertura del segnale di interlock esterno.	Ripristinare il corto circuito tra il pin 3 ed il pin8 del connettore J1, o chiudere il segnale di interlock esterno.
FAULT: OVERTIME SX	Durante l'avvio della pompa nel modo "soft start", la pompa non ha raggiunto la velocità prevista ad ogni passo entro 15 minuti. (X può valere da 0 a 9 ed indica il passo non superato).	Verificare che il sistema non presenti delle perdite. Premere due volte il pulsante START per riavviare la pompa.
FAULT: PUMP OVERTEMP.	La temperatura del cuscinetto superiore o della pompa ha superato i 60 °C.	Attendere che la temperatura ritorni al di sotto della soglia. Premere due volte il pulsante START per riavviare la pompa.
FAULT: CONTROLLER OVERTEMPERATURE	La temperatura del trasformatore del controller ha superato i 90 °C.	Attendere che la temperatura ritorni al di sotto della soglia. Premere due volte il pulsante START per riavviare la pompa.
FAULT: TOO HIGH LOAD	Durante il funzionamento normale (dopo la fase di avvio) la corrente assorbita dalla pompa è maggiore di quella programmata (1,5 A).	Verificare che il rotore della pompa abbia la possibilità di ruotare liberamente. Premere due volte il pulsante START per riavviare la pompa.
FAULT: SHORT CIRCUIT	Durante il funzionamento normale (dopo la fase di avvio) la connessione di uscita è in corto circuito (corrente di uscita maggiore di 2,2 A).	Verificare i collegamenti tra pompa e controller. Premere due volte il pulsante START per riavviare la pompa.
SYSTEM OVERRIDE	La pompa è stata fermata da un segnale di emergenza proveniente da un contatto remoto.	Staccare il cavo di alimentazione del controller e correggere la causa dell'emergenza. Ricollegare il cavo di alimentazione e premere due volte il pulsante START per riavviare la pompa.
OVERVOLTAGE	Si è verificato un guasto nella sezione di alimentazione del controller, o il controller ha ricevuto un segnale spurio.	Premere due volte il pulsante START per riavviare la pompa. Se il messaggio si ripresenta rivolgersi in Varian per la manutenzione.
CONTROLLER FAILURE	Interruzione fusibile sul secondario di potenza.	Rivolgersi alla Varian per la Manutenzione.

ALLGEMEINES

Dieser Apparat ist für Fachbetriebe bestimmt. Vor Gebrauch sollte der Benutzer dieses Handbuch sowie alle weiteren mitgelieferten Zusatzdokumentationen genau lesen. Bei Nichtbeachtung - auch teilweise - der enthaltenen Hinweise, unsachgemäßem Gebrauch durch ungeschultes Personal, nicht autorisierten Eingriffen und Mißachtung der einheimischen, hier zur Geltung kommenden Bestimmungen übernimmt die Firma Varian keinerlei Haftung.

Die Controller der Serie Turbo-V 70 sind mikroprozessorgesteuerte Frequenzwandler. Sie sind mit Festkörperbauteilen gefertigt und verfügen über ein Selbstdiagnose- und ein Selbstschutzsystem.

Die Controller steuern die Pumpen der Serie Turbo-V 70 (durch einen 10-Schritte-Prozeß) in der Startphase, indem sie die Spannung und die Stromstärke im Verhältnis zur Pumpengeschwindigkeit kontrollieren. Sie enthalten alle für den automatischen Betrieb der Pumpenserie Turbo-V 70 erforderlichen Schaltungen.

Mittels Hilfsverbinder sind die Fernsteuerungen für Pumpenstart- und stopp, die Signale für die Anzeige des Pumpenzustands, die Start- und Stoppsteuerungen der Vorvakuumumpfen, sowie die Sperrsignale (für Druckschalter, Wasserstrom-Kontrollschalter, etc.) verfügbar. In den folgenden Abschnitten sind alle erforderlichen Informationen für die Sicherheit des Bedieners bei der Anwendung des Geräts aufgeführt. Detaillierte technische Informationen sind im Anhang "Technical Information" enthalten.

In dieser Gebrauchsanleitung werden Sicherheitshinweise folgendermaßen hervorgehoben:



GEFAHR!

Die Gefahrenhinweise lenken die Aufmerksamkeit des Bedieners auf eine bestimmte Prozedur oder Praktik, die bei unkorrekter Ausführung schwere Verletzungen hervorrufen können.



ACHTUNG!

Die Warnhinweise vor bestimmten Prozeduren machen den Bediener darauf aufmerksam, daß bei Nichteinhaltung Schäden an der Anlage entstehen können.

ANMERKUNG

Die Anmerkungen enthalten wichtige Informationen, ie aus dem Text hervorgehoben werden.

LAGERUNG

Beim Transport und bei der Lagerung der Controller müssen folgende klimatische Verhältnisse eingehalten werden:

- Temperatur: von -20 °C bis +70 °C
- Relative Luftfeuchtigkeit: 0-95% (nicht kondensierend)

VOR DER INSTALLATION

Der Controller wird mit einer speziellen Schutzverpackung geliefert. Eventuelle Transportschäden müssen der zuständigen örtlichen Verkaufsstelle gemeldet werden.

Beim Auspacken vorsichtig vorgehen, damit der Controller nicht fällt oder Stößen ausgesetzt wird.

Das Verpackungsmaterial muß korrekt entsorgt werden. Es ist vollständig recyclebar und entspricht der EG-Richtlinie 85/399 für Umweltschutz.

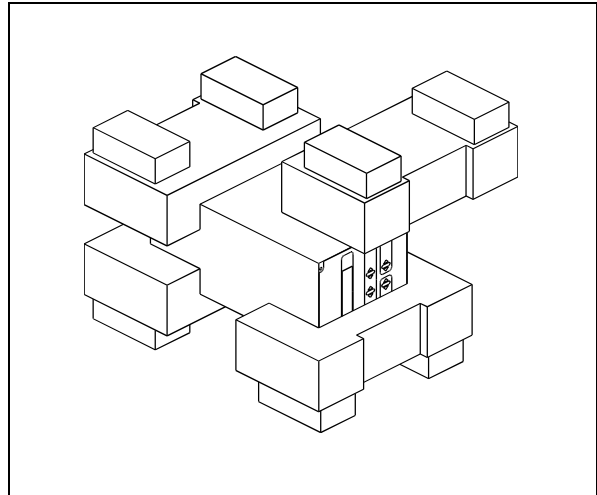

*Verpackung der Controller
969-9405 und 969-9505*

Alle Varian-Controller sind für eine bestimmte Anschlußspannung ausgelegt:

- Modell 969-9405 für 220 VWs
- Modell 969-9505 für 120 VWs

Soll die Anschlußspannung geändert werden, ist folgendes zu tun:

- Das Netzkabel an der rückwärtigen Tafel des Controllers ausstecken.
- Am Spannungseingangsmodul die eingestellte Anschlußspannung ablesen.
- Das Spannungswahlmodul mit Sicherung mit Hilfe eines kleinen Schraubenziehers herausziehen.
- Die gewünschte Anschlußspannung wählen, und dann das Modul wieder einsetzen.
- Sicherstellen, daß die korrekte Spannung gewählt wurde, und das Netzkabel wieder anschließen.

INSTALLATION



GEFAHR!

Der Controller wird mit einem Netzkabel geliefert, das 3 Drähte enthält und mit einem den internationalen Normen entsprechenden Stecker ausgerüstet ist. Es sollte immer dieses Netzkabel benutzt werden, das an eine korrekt geerdete Steckdose anzuschließen ist, um Stromentladungen zu vermeiden.

Im Inneren des Controllers entstehen hohe Spannungen, die schwere Schäden verursachen und zum Teil lebensgefährlich sein können. Vor jedem Montage- bzw. Wartungseingriff muß deshalb der Netzstecker gezogen werden.

ANMERKUNG

Der Controller kann auf einen Tisch oder ein Gestell montiert werden. In beiden Fällen muß auf die ungehinderte Zirkulation der Kühlluft im Bereich des Geräts geachtet werden.

Der Controller darf nicht in Umgebungen installiert u/o benutzt werden, die Witterungseinflüssen (Regen, Frost, Schnee), Staub und aggressiven Gasen ausgesetzt sind und in denen Explosions- und erhöhte Brandgefahr besteht.

Beim Betrieb müssen folgende Umgebungsbedingungen eingehalten werden:

- Temperatur: von +0 °C bis +40 °C
- Relative Luftfeuchtigkeit: 0 - 95 % (nicht kondensierend).

Für den Anschluß des Controllers an die Pumpe muß das zum Controller gehörende Kabel benutzt werden.

ANMERKUNG

Die Controller-Modelle 969-9405 und 969-9505 haben das Pumpenanschlußkabel an der Rückplatte befestigt.

Für weitere Hinweise bezüglich Anschlüsse und Montage des bestellbaren Zubehörs siehe "Technical Information".

GEBRAUCH

In diesem Kapitel sind die wichtigsten Betriebsvorgänge aufgeführt. Für weitere Hinweise bezüglich Anschlüsse und Montage des bestellbaren Zubehörs siehe Kapitel "Use" im Anhang zu "Technical Information".

Vor Benutzung des Controllers sämtliche elektrischen und pneumatischen Anschlüsse ausführen, und die Betriebsanleitung der angeschlossenen Pumpe durchlesen.



GEFAHR!

Steht die Pumpe auf einem Tisch, muß auf den stabilen Stand geachtet werden, da sonst die Gefahr von Personen- und Geräteschäden besteht. Die Pumpe nie einschalten, wenn der Eingangsflansch nicht am System angeschlossen bzw. nicht mit dem Schließflansch abgedeckt ist.

ANMERKUNG

Der Wiederverschleiß-Verbinder J1 muß mit seiner Brücke angeschlossen bleiben, wenn kein externer Anschluß erfolgt. Die Vorvakuumpumpe und die Turbo-V-Pumpe können gleichzeitig eingeschaltet werden.

Steuerungen, Anzeigen und Verbinder des Controllers

Nachstehend werden die Steuertafel des Controllers sowie die Verbindungstafeln beschrieben. Für weitere Einzelheiten siehe "Technical Information".

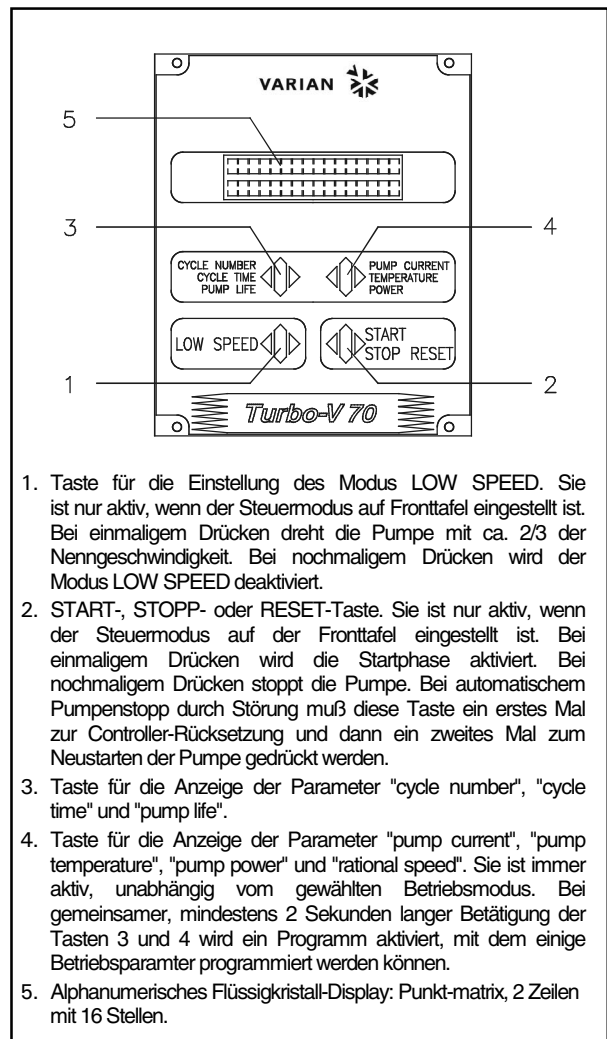

1. Taste für die Einstellung des Modus LOW SPEED. Sie ist nur aktiv, wenn der Steuermodus auf Fronttafel eingestellt ist. Bei einmaligem Drücken dreht die Pumpe mit ca. 2/3 der Nenngeschwindigkeit. Bei nochmaligem Drücken wird der Modus LOW SPEED deaktiviert.
2. START-, STOPP- oder RESET-Taste. Sie ist nur aktiv, wenn der Steuermodus auf der Fronttafel eingestellt ist. Bei einmaligem Drücken wird die Startphase aktiviert. Bei nochmaligem Drücken stoppt die Pumpe. Bei automatischem Pumpenstopp durch Störung muß diese Taste ein erstes Mal zur Controller-Rücksetzung und dann ein zweites Mal zum Neustarten der Pumpe gedrückt werden.
3. Taste für die Anzeige der Parameter "cycle number", "cycle time" und "pump life".
4. Taste für die Anzeige der Parameter "pump current", "pump temperature", "pump power" und "rational speed". Sie ist immer aktiv, unabhängig vom gewählten Betriebsmodus. Bei gemeinsamer, mindestens 2 Sekunden langer Betätigung der Tasten 3 und 4 wird ein Programm aktiviert, mit dem einige Betriebsparameter programmiert werden können.
5. Alphanumerisches Flüssigkristall-Display: Punkt-matrix, 2 Zeilen mit 16 Stellen.

Fronttafel der Controller
969-9405 und 969-9505

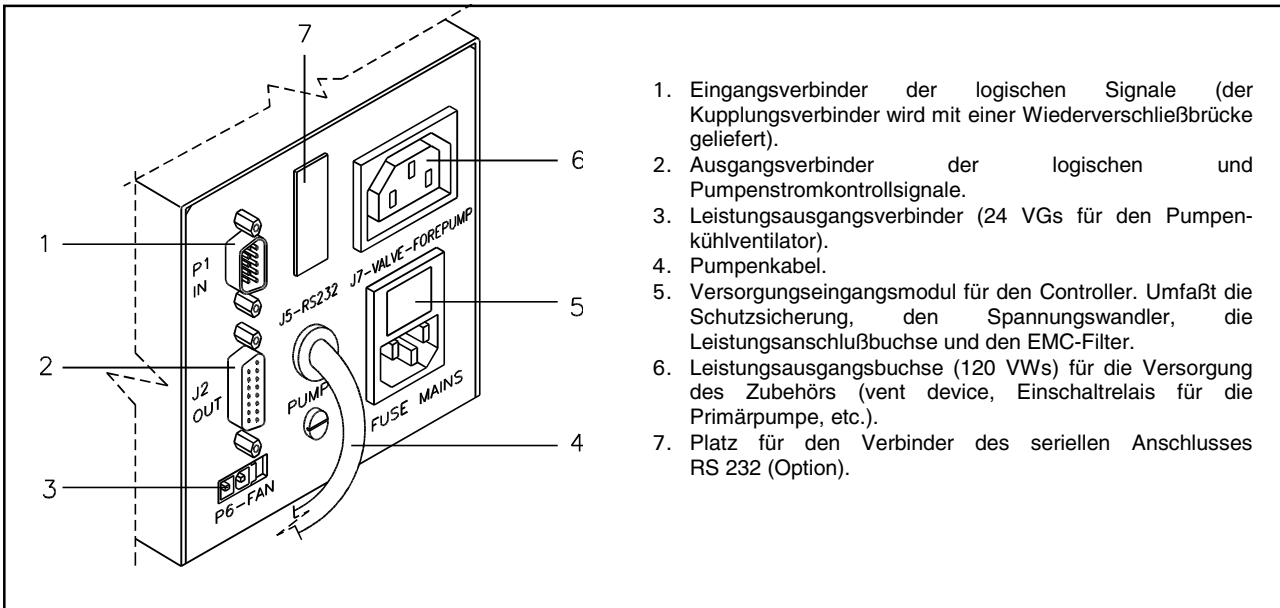

1. Eingangsverbinder der logischen Signale (der Kupplungsverbinder wird mit einer Wiederverschließbrücke geliefert).
2. Ausgangsverbinder der logischen und Pumpenstromkontrollsignale.
3. Leistungsausgangsverbinder (24 VGs für den Pumpenkühlventilator).
4. Pumpenkabel.
5. Versorgungseingangsmodul für den Controller. Umfaßt die Schutzsicherung, den Spannungswandler, die Leistungsanschlußbuchse und den EMC-Filter.
6. Leistungsausgangsbuchse (120 VWs) für die Versorgung des Zubehörs (vent device, Einschaltrelais für die Primärpumpe, etc.).
7. Platz für den Verbinder des seriellen Anschlusses RS 232 (Option).

Rücktafel der Controller 969-9405 und 969-9505

BEDIENUNG

Einschalten des Controllers

Zum Einschalten des Controllers genügt es, das Netzkabel an die Steckdose anzuschließen.

Pumpenstart

Zum Starten der Pumpe muß die Taste START an der Fronttafel gedrückt werden.

Pumpenstopp

Zum Stoppen der Pumpe muß die STOPP-Taste an der Fronttafel gedrückt werden.

WARTUNG

Die Controller der Serie Turbo-V 70 sind wartungsfrei. Eventuell erforderliche Eingriffe müssen von dazu befugtem Fachpersonal ausgeführt werden.

Bei einem Defekt kann der Varian-Reparaturdienst bzw. der "Varian advanced exchange service" in Anspruch genommen werden, der für die Erneuerung defekter Controller sorgt.



GEFAHR!

Vor jedem Eingriff am Controller muß der Netzstecker gezogen werden.

Eine eventuelle Verschrottung muß unter Einhaltung der einschlägigen landesüblichen Vorschriften erfolgen.

FEHLERMELDUNGEN

In einigen Störfällen zeigt das Selbstdiagnosessystem des Controllers die in der nachstehenden Tabelle zusammengefaßten Meldungen an.

MELDUNG	BESCHREIBUNG	BEHEBUNG
CHECK CONNECTION TO PUMP	Fehlfunktion der Pumpen-Controller Verbindung.	Sicherstellen, daß das Verbindungskabel zwischen Pumpe und Controller an beiden Seiten korrekt befestigt ist und keine Unterbrechung vorliegt. Die Pumpe durch zweimalige Betätigung der START-Taste neustarten.
PUMP WAITING INTERLOCK	Das Interlock-Signal auf dem Verbinder P1 ist wegen der Kurzschlußunterbrechung zwischen Pin 3 und Pin 8 des Verbinders K1 oder wegen der Öffnung des externen Interlock-Signals aktiv.	Den Kurzschluß zwischen Pin 3 und Pin 8 des Verbinders J1 rücksetzen oder das externe Interlock-Signal schließen.
FAULT: OVERTIME SX	Beim Pumpenstart im Modus "soft start" hat die Pumpe die bei jedem Schritt vorgesehene Geschwindigkeit innerhalb von 15 Minuten nicht erreicht (X kann 0-9 sein und zeigt den nicht überwundenen Schritt an).	Sicherstellen, daß das System keine Leckagen aufweist. Die Pumpe durch zweimalige Betätigung der START-Taste neustarten.
FAULT: PUMP OVERTEMP.	Die Temperatur des oberen Lagers bzw. der Pumpe hat 60 °C überschritten.	Warten bis die Temperatur unter den Schwellenwert gesunken ist. Die Pumpe durch zweimalige Betätigung der START-Taste neustarten.
FAULT: CONTROLLER OVERTEMPERATURE	Die Temperatur des Controller-Trafos hat 90 °C überschritten.	Warten bis die Temperatur unter den Schwellenwert gesunken ist. Die Pumpe durch zweimalige Betätigung der START-Taste neustarten.
FAULT: TOO HIGH LOAD	Während des Normalbetriebs (nach der Startphase) ist die Pumpenstromaufnahme größer als die vorgesehene (1,5 A).	Sicherstellen, daß der Pumpenrotor ungehindert drehen kann. Die Pumpe durch zweimalige Betätigung der START-Taste neustarten.
FAULT: SHORT CIRCUIT	Während des Normalbetriebs (nach der Startphase) erfolgt ein Kurzschluß der Ausgangsverbinding (Ausgangsstrom größer als 2,2 A).	Die Verbindung zwischen Pumpe und Controller prüfen. Die Pumpe durch zweimalige Betätigung der START-Taste neustarten.
SYSTEM OVERRIDE	Die Pumpe wurde durch ein von einem entfernten Kontakt kommendes Notsignal gestoppt.	Das Netzkabel des Controllers ausstecken und die Störungsursache beheben. Das Netzkabel wieder anschließen und die Pumpe durch zweimalige Betätigung der START-Taste neustarten.
OVERVOLTAGE	Defekt im Versorgungsbereich des Controllers bzw. der Controller hat ein falsches Signal erhalten	Die Pumpe durch zweimalige Betätigung der START-Taste neustarten. Erscheint die Meldung wieder sollte der Varian-Wartungsdienst gerufen werden.
CONTROLLER FAILURE	Unterbrechung der Schmelzsicherung am sekundären Leistungsstromkreis.	Zur Instandhaltung an Varian wenden.

INDICATIONS GENERALES

Cet appareillage a été conçu en vue d'une utilisation professionnelle. Il est conseillé à l'utilisateur de lire attentivement cette notice d'instructions ainsi que toute autre indication supplémentaire fournie par Varian, avant l'utilisation de l'appareil. Varian décline par conséquent toute responsabilité en cas d'observation totale ou partielle des instructions données, d'utilisation incorrecte de la part d'un personnel non formé, d'opérations non autorisées ou d'un emploi contraire aux réglementations nationales spécifiques. Les contrôleurs de la série Turbo-V 70 sont des convertisseurs de fréquence, contrôlés par un microprocesseur, réalisés avec des éléments à l'état solide et ayant des capacités d'autodiagnostic et d'autoprotection. Les contrôleurs pilotent les pompes de la série Turbo-V 70 (par un processus subdivisé en dix pas) lors de la phase de mise en marche, en contrôlant la tension et le courant par rapport à la vitesse atteinte par la pompe. Ils incorporent l'ensemble de circuits nécessaire au fonctionnement automatique des pompes de la série Turbo-V 70. Un connecteur auxiliaire permet de disposer des commandes de mise en marche et d'arrêt de la pompe à distance, des signaux indiquant l'état opérationnel de la pompe, des commandes de mise en marche et d'arrêt de la pompe à pré-vidé ainsi que de signaux de blocage (pour interrupteurs à pression, interrupteurs de contrôle du flux de l'eau, etc.). Les paragraphes suivants donnent toutes les indications nécessaires à garantir la sécurité de l'opérateur pendant l'utilisation de l'appareillage. Des renseignements plus détaillés se trouvent dans l'appendice "Technical Information".

Cette notice utilise les signes conventionnels suivants:



DANGER!

Les messages de danger attirent l'attention de l'opérateur sur une procédure ou une manoeuvre spéciale qui, si elle n'est pas effectuée correctement, risque de provoquer de graves lésions.



ATTENTION

Les messages d'attention apparaissent avant certaines procédures qui, si elles ne sont pas observées, pourraient endommager sérieusement l'appareillage.

NOTE

Les notes contiennent des renseignements importants, isolés du texte.

EMMAGASINAGE

Pendant le transport et l'emmagasinage des contrôleurs, il faudra veiller à respecter les conditions environnementales suivantes:

- Température: de - 20 °C à + 70 °C
- Humidité relative: 0 - 95% (non condensante).

PREPARATION POUR L'INSTALLATION

Le contrôleur est fourni dans un emballage de protection spécial; si l'on constate des marques de dommages pouvant s'être produits pendant le transport, contacter aussitôt le bureau de vente local. Pendant l'opération d'ouverture de l'emballage, veiller tout particulièrement à ne pas laisser tomber le contrôleur et à ne lui faire subir aucun choc. Ne pas jeter l'emballage dans la nature. Le matériel est entièrement recyclable et il est conforme aux directives CEE 83/399 en matière de protection de l'environnement.

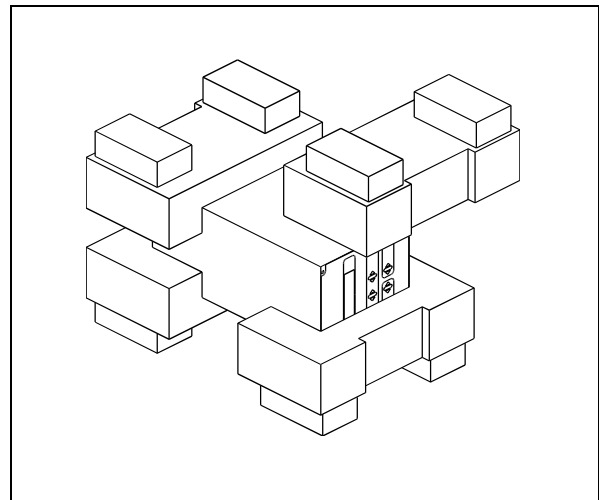

*Emballage des Contrôleurs
969-9405 et 969-9505*

Chaque contrôleur est fourni par Varian pré-équipé pour une certaine tension d'alimentation:

- Le modèle 969-9405 pour 220 Vca
- Le modèle 969-9505 pour 120 Vca.

S'il est nécessaire de changer la tension d'alimentation, procéder de la façon suivante:

- Déconnecter le câble d'alimentation du tableau arrière du contrôleur.
- Vérifier, sur le module d'entrée de tension, la tension d'alimentation prévue.
- Enlever le module de sélection de tension à Sélectionner la tension d'alimentation voulue, puis replacer fermement le module dans son logement.
- S'assurer que la tension correcte a été sélectionnée, puis reconnecter le câble d'alimentation.

INSTALLATION



DANGER!

Le contrôleur est doté d'un câble d'alimentation à trois fils avec une fiche du type approuvé au niveau international. Utiliser toujours ce câble d'alimentation et introduire la fiche dans une prise pourvue d'un branchement approprié à la masse, afin d'éviter toute décharge électrique. A l'intérieur du contrôleur se développent de hautes tensions qui peuvent causer de graves dommages et même la mort. Avant d'effectuer toute opération d'installation ou d'entretien du contrôleur, le débrancher de la prise d'alimentation.

NOTE

Le contrôleur peut être installé sur un plateau d'appui ou à l'intérieur d'un rack prévu à cet effet. Il est en tout cas nécessaire que l'air de refroidissement puisse circuler librement à l'intérieur de l'appareil. Ne pas installer et/ou utiliser le contrôleur dans des milieux exposés à des agents atmosphériques (pluie, gel, neige), à des poussières, à des gaz de combat ainsi que dans des milieux explosifs ou à risque élevé d'incendie.

Pendant le fonctionnement, il est nécessaire de respecter les conditions environnementales suivantes:

- Température: de 0 °C à + 40 °C
- Humidité relative: 0 - 95% (non condensante).

Pour la connexion du contrôleur à la pompe correspondante, utiliser le câble du contrôleur prévu à cet effet.

NOTE

Les contrôleurs modèle 969-9405 et 969-9505 sont dotés d'un câble de connexion à la pompe fixé au tableau arrière du contrôleur.

Pour les autres connexions et pour l'installation des accessoires en option, voir la section "Technical Information".

UTILISATION

Dans ce paragraphe, on indique les principales procédures opérationnelles. Pour tous autres détails et pour les procédures concernant des connexions ou des éléments en option, se reporter au paragraphe "Use" de l'appendice "Technical Information".

Avant d'utiliser le contrôleur, effectuer toutes les connexions électriques et pneumatiques et se référer à la notice de la pompe connectée.



DANGER!

Pour éviter tous dommages aux personnes et à l'appareil, si la pompe est placée sur un plateau d'appui s'assurer que ce dernier est stable. Ne jamais faire fonctionner la pompe si la bride d'entrée n'est pas connectée au système ou n'est pas fermée à l'aide de la bride de fermeture.

NOTE

Laisser le connecteur de réenclenchement J1 connecté à sa barrette s'il n'est procédé à aucune connexion extérieure. La pompe à pré-vide et la pompe Turbo-V peuvent être mises en marche simultanément.

Commandes, Indicateurs et Connecteurs du Contrôleur

On présente ci-dessous le tableau de commande du Contrôleur ainsi que les tableaux d'interconnexion. Pour de plus amples détails, se reporter à la section "Technical Information".



Tableau avant des Contrôleurs
969-9405, 969-9505



Tableau arrière des Contrôleurs 969-9405 et 969-9505

PROCEDURES D'UTILISATION

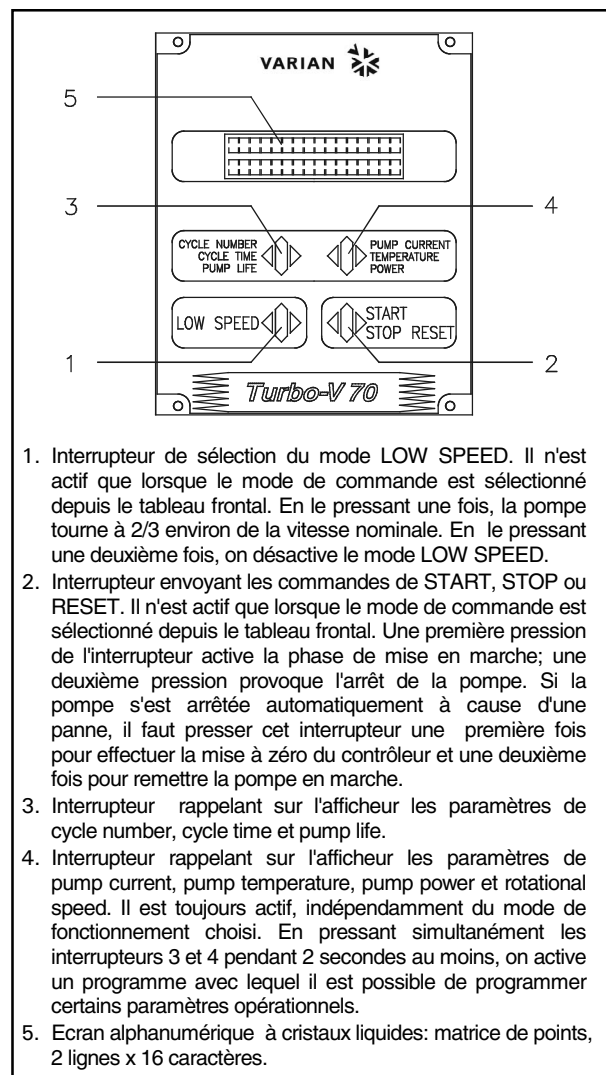
Allumage du Contrôleur

Pour allumer le contrôleur, il suffit d'introduire le câble d'alimentation dans la prise du réseau.

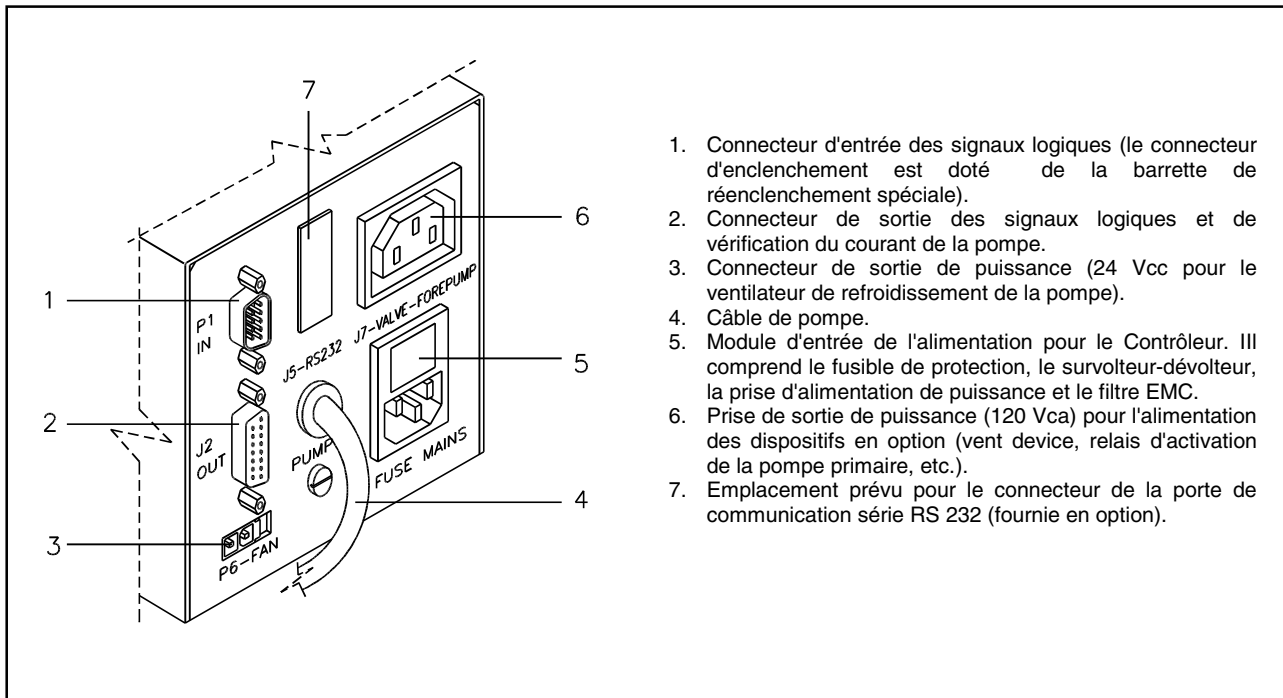
Mise en marche de la Pompe

Pour mettre la pompe en marche, presser l'interrupteur START du tableau avant.

Arrêt de la Pompe

Pour arrêter la pompe, presser l'interrupteur STOP du tableau avant.

ENTRETIEN

Les contrôleurs de la série Turbo-V 70 n'exigent aucun entretien. Toute opération doit être effectuée par un personnel agréé.

En cas de panne, il est possible de s'adresser au Service de réparation Varian ou bien au "Varian advance exchange service" qui permet d'obtenir un contrôleur régénéré à la place du contrôleur détraqué.

En cas de mise au rebut de la pompe, procéder à son élimination conformément aux réglementations nationales en la matière.



DANGER!

Avant d'effectuer toute opération sur le contrôleur, débrancher le câble d'alimentation.

MESSAGES D'ERREUR

Dans certains cas de panne, l'ensemble de circuits d'autodiagnostic du contrôleur présente certains messages d'erreur indiqués dans le tableau ci-dessous.

MESSAGE	DESCRIPTION	INTERVENTION
CHECK CONNECTION TO PUMP	Dysfonctionnement de la connexion entre la pompe et le contrôleur.	S'assurer que le câble de connexion entre la pompe et le contrôleur est bien fixé aux deux extrémités et qu'il n'est pas coupé. Presser deux fois l'interrupteur START pour réactiver la pompe.
PUMP WAITING INTERLOCK	Le signal d'interlock situé sur le connecteur P1 est actif à cause de la coupure du court-circuit entre le pin 3 et le pin 8 du connecteur J1 ou à cause de l'ouverture du signal d'interlock extérieur.	Rétablir le court-circuit entre le pin 3 et le pin 8 du connecteur J1 ou fermer le signal d'interlock extérieur.
FAULT: OVERTIME SX	Pendant la mise en marche de la pompe dans le mode soft start", la pompe n'a pas atteint la vitesse prévue à chaque pas dans les 15 minutes (X peut valoir de 0 à 9 et indique le pas non franchi).	S'assurer que le système ne présente pas de fuites. Presser deux fois l'interrupteur START pour remettre la pompe en marche.
FAULT: PUMP OVERTEMP.	La température du palier supérieur ou de la a dépassé 60 °C.	Attendre que la température retourne au-dessous du seuil. Presser deux fois l'interrupteur START pour remettre la pompe en marche.
FAULT: CONTROLLER OVERTEMPERATURE	La température du transformateur du contrôleur a dépassé 90 °C.	Attendre que la température retourne au-dessous du seuil. Presser deux fois l'interrupteur START pour remettre la pompe en marche.
FAULT: TOO HIGH LOAD	Pendant le fonctionnement normal (après la phase de mise en marche), le courant absorbé par la pompe est plus grand que celui qui a été programmé (1,5 A).	S'assurer que le rotor de la pompe a la possibilité de tourner librement. Presser deux fois l'interrupteur START pour remettre la pompe en marche.
FAULT: SHORT CIRCUIT	Pendant le fonctionnement normal (après la phase de mise en marche), la connexion de sortie est en court-circuit (courant de sortie plus grand que 2,2 A).	Vérifier les connexions entre la pompe et le contrôleur. Presser deux fois l'interrupteur START pour remettre la pompe en marche.
SYSTEM OVERRIDE	La pompe a été arrêtée par un signal d'alerte provenant d'un contact éloigné.	Débrancher le câble d'alimentation du contrôleur et corriger la cause de l'alerte. Reconnecter le câble d'alimentation et presser deux fois l'interrupteur START pour remettre la pompe en marche.
OVERVOLTAGE	Il s'est produit une panne de la section d'alimentation du contrôleur, ou bien le contrôleur a reçu un faux signal.	Presser deux fois l'interrupteur START pour remettre la pompe en marche. Si le message se présente à nouveau, s'adresser à Varian pour l'entretien.
CONTROLLER FAILURE	Interruption du fusible sur le secondaire de puissance.	Contacteur Varian pour l'entretien.

INFORMACIÓN GENERAL

Este equipo se ha concebido para un uso profesional. El usuario deberá leer atentamente el presente manual de instrucciones y cualquier otra información suplementaria facilitada por Varian antes de utilizar el equipo. Varian se considera libre de cualquier responsabilidad debida al incumplimiento total o parcial de las instrucciones, al uso poco apropiado por parte de personal sin formación, a las operaciones no autorizadas o al uso que no cumpla con las normas nacionales específicas. Los controlers de la serie Turbo-V 70 son convertidores de frecuencia, controlados por un microprocesador, realizados con componentes en estado sólido y con capacidad de autodiagnosis y autoprotección. Los controlers pilotan las bombas de la serie Turbo-V 70 (con un proceso dividido en diez pasos) durante la fase de puesta en marcha, controlando la tensión y la corriente en relación a la velocidad alcanzada por la bomba. Estos incorporan todos los circuitos de la serie Turbo-V 70.

Mediante un conector auxiliar están disponibles los mandos para la puesta en marcha y la parada de la bomba de remoto, las señales que indican el estado operativo de la bomba, los mandos para la puesta en marcha y la parada de la bomba de pre-vacío, señales de control del caudal del agua, etc.). En los apartados siguientes se facilita toda la información necesaria para garantizar la seguridad del operador durante el uso del equipo. Una información más detallada se facilita en el Suplemento "Technical Information".

Este manual utiliza los símbolos convencionales siguientes:



¡PELIGRO!

Los mensajes de peligro atraen la atención del operador sobre un procedimiento o una operación específica que, al no realizarse correctamente, podría provocar graves lesiones personales.



ATENCIÓN

Los mensajes de atención se visualizan antes de procedimientos que, al no respetarse, podrían provocar daños al equipo.

NOTA

Las notas contienen información importante extraída del texto.

ALMACENAMIENTO

Durante el transporte y el almacenamiento de los controlers se deberá cumplir con las condiciones ambientales siguientes:

- temperatura: de -20 °C a +70 °C
- humedad relativa: 0 - 95% (no condensadora)

PREPARACIÓN PARA LA INSTALACIÓN

El controler se suministra en un embalaje de protección especial; si se observan señales de daños, que podrían haberse producido durante el transporte, ponerse en contacto con la oficina de venta más cercana. Durante la operación de desembalaje, prestar una atención especial a no dejar caer el controler y evitarle golpes. No dispersar el embalaje en el medio ambiente. El material es totalmente reciclable y cumple con la directiva CEE 85/399 para la preservación del medio ambiente.

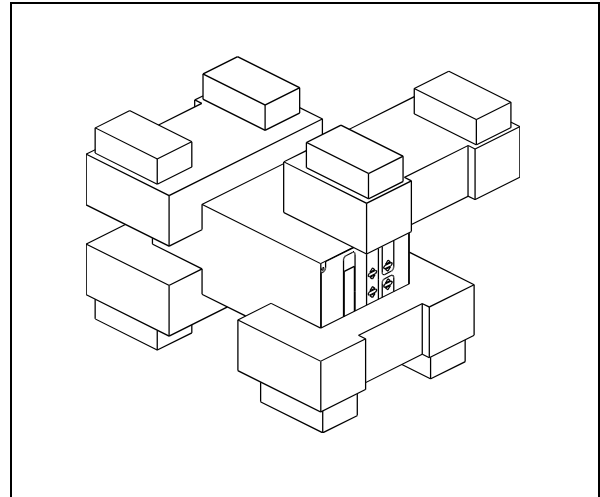

*Embalaje de los Controlers
969-9405 y 969-9505*

Cada controler llega de la Varian preparado para una cierta tensión de alimentación:

- el modelo 969-9405 por 220 Vac
- el modelo 969-9505 por 120 Vac

De ser necesario cambiar la tensión de alimentación, efectuar el procedimiento siguiente:

- Desconectar el cable de alimentación del panel trasero de los controlers.
- Comprobar en el módulo de entrada de tensión la tensión de alimentación preparada.
- Extraer el módulo de selección de la tensión con fusible utilizando un pequeño destornillador.
- Seleccionar la tensión de alimentación deseada y luego volver a introducir con determinación el módulo en su alojamiento.
- Comprobar que se ha seleccionado la tensión correcta y luego volver a conectar el cable de alimentación.

INSTALACIÓN



¡PELIGRO!

El controler va dotado de un cable de alimentación de tres hilos con una clavija de tipo aprobado a nivel internacional. Utilizar siempre este cable de alimentación e introducir la clavija en un enchufe con una conexión de masa adecuada para evitar descargas eléctricas. Dentro del controler se desarrollan altas tensiones que pueden causar graves daños o la muerte. Antes de efectuar cualquier operación de instalación o mantenimiento del controler desconectarlo del enchufe de alimentación.

NOTA

El controler puede instalarse en una mesa o dentro de un rack específico. En cualquier caso, es necesario que el aire de refrigeración pueda circular libremente alrededor del aparato.

No instalar y/o utilizar el controler en ambientes expuestos a agentes atmosféricos (lluvia, hielo y nieve), polvos, gases agresivos, en ambientes explosivos o con alto riesgo de incendio.

Durante el funcionamiento es necesario que se respeten las condiciones ambientales siguientes:

- temperatura: de 0 °C a + 40 °C
- humedad relativa: 0 - 95% (no condensadora).

Para la conexión del controler con la bomba correspondiente utilizar el cable específico del controler.

NOTA

Los controlers del modelo 969-9405 y 969-9505 llevan el cable de conexión a la bomba fijado al panel trasero del Controler.

Para otras conexiones y la instalación de los accesorios opcionales, véase la sección "Technical Information".

USO

En este apartado se citan los procedimientos operativos principales. Para más detalles y para procedimientos que impliquen conexiones u opcionales especiales, les remitimos al apartado "Use" del anexo "Technical Information".

Antes de usar el controler efectuar todas las conexiones eléctricas y neumáticas y consultar el manual de la bomba conectada.



¡PELIGRO!

Para evitar lesiones a las personas y al aparato, si la bomba está apoyada sobre una mesa cerciorarse que es estable. No poner en marcha nunca la bomba si la brida de entrada no está conectada al sistema o no está cerrada con la brida de cierre.

NOTA

El conector de cierre J1 ha de dejarse conectado con su conector puente si no se efectúa ninguna conexión exterior. La bomba pre-vacío y la bomba Turbo-V pueden encenderse simultáneamente.

Mandos, indicadores y conectores del controler

A continuación se ilustran el panel de mando del controler y los paneles de interconexión. Para más detalles consultar la sección "Technical Information".

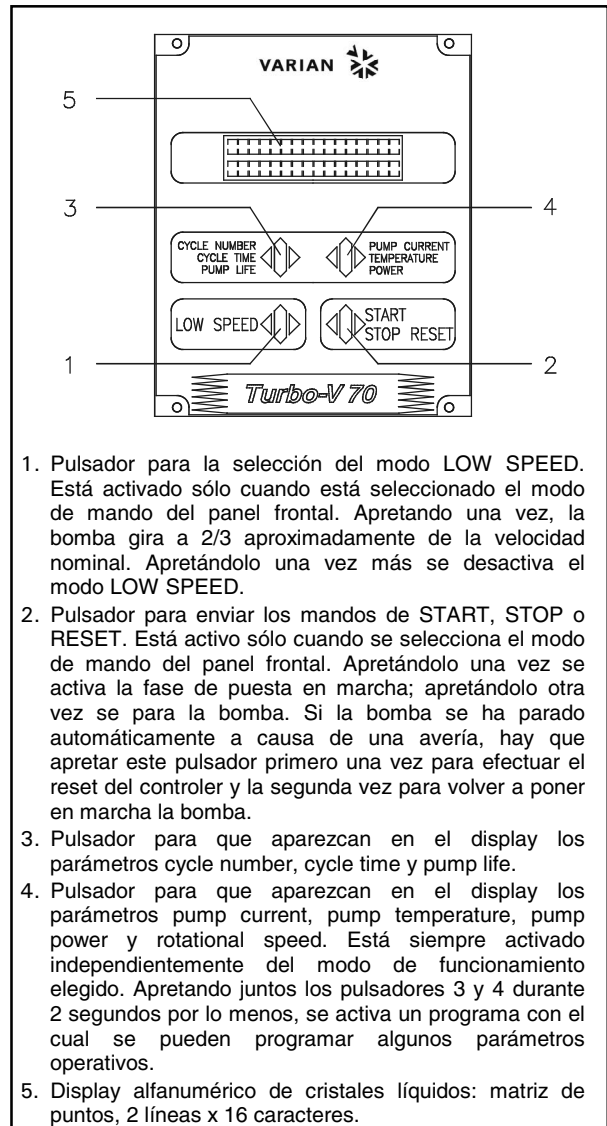

1. Pulsador para la selección del modo LOW SPEED. Está activado sólo cuando está seleccionado el modo de mando del panel frontal. Apertando una vez, la bomba gira a 2/3 aproximadamente de la velocidad nominal. Apertándolo una vez más se desactiva el modo LOW SPEED.
2. Pulsador para enviar los mandos de START, STOP o RESET. Está activo sólo cuando se selecciona el modo de mando del panel frontal. Apertándolo una vez se activa la fase de puesta en marcha; apertándolo otra vez se para la bomba. Si la bomba se ha parado automáticamente a causa de una avería, hay que apertar este pulsador primero una vez para efectuar el reset del controler y la segunda vez para volver a poner en marcha la bomba.
3. Pulsador para que aparezcan en el display los parámetros cycle number, cycle time y pump life.
4. Pulsador para que aparezcan en el display los parámetros pump current, pump temperature, pump power y rotational speed. Está siempre activado independientemente del modo de funcionamiento elegido. Apertando juntos los pulsadores 3 y 4 durante 2 segundos por lo menos, se activa un programa con el cual se pueden programar algunos parámetros operativos.
5. Display alfanumérico de cristales líquidos: matriz de puntos, 2 líneas x 16 caracteres.

Panel frontal del Controller
969-9405 y 969-9505

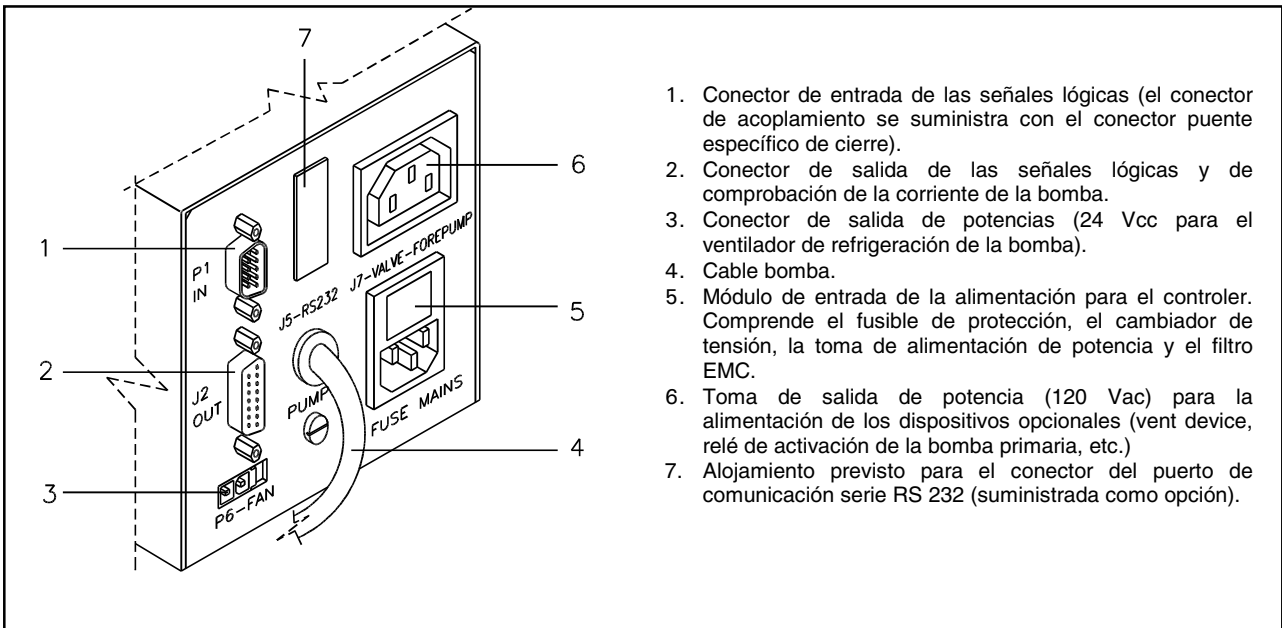

1. Conector de entrada de las señales lógicas (el conector de acoplamiento se suministra con el conector puente específico de cierre).
2. Conector de salida de las señales lógicas y de comprobación de la corriente de la bomba.
3. Conector de salida de potencias (24 Vcc para el ventilador de refrigeración de la bomba).
4. Cable bomba.
5. Módulo de entrada de la alimentación para el controler. Comprende el fusible de protección, el cambiador de tensión, la toma de alimentación de potencia y el filtro EMC.
6. Toma de salida de potencia (120 Vac) para la alimentación de los dispositivos opcionales (vent device, relé de activación de la bomba primaria, etc.)
7. Alojamiento previsto para el conector del puerto de comunicación serie RS 232 (suministrada como opción).

Panel trasero del controler 969-9405 y 969-9505

PROCEDIMIENTOS DE USO

Encendido del controler

Para encender el controler es suficiente introducir el cable de alimentación en la toma de red.

Puesta en marcha de la Bomba

Para poner en marcha la bomba hay que apretar el pulsador START del panel frontal.

Parada de la Bomba

Para detener la bomba hay que apretar el pulsador STOP del panel frontal.

MANTENIMIENTO

Los controlers de la serie Turbo-V 70 no necesitan ningún mantenimiento. Cualquier operación ha de ser efectuada por personal autorizado.

En caso de avería es posible utilizar el servicio de reparación Varian o del "Varian advance exchange service", que permite obtener un controler regenerado en vez del averiado.

En caso de que un controler se tenga que desguazar, efectuar su eliminación respetando las normas nacionales específicas.



¡PELIGRO!

Antes de efectuar cualquier operación en el controler desenchufar el cable de alimentación.

MENSAJES DE ERROR

En algunos casos de avería los circuitos de autodiagnosís del controler presenta algunos mensajes de error detallados en la tabla siguiente.

MENSAJE	DESCRIPCIÓN	ACCIÓN CORRECTIVA
CHECK CONNECTION TO PUMP	Mal funcionamiento en la conexión entre la bomba y el Controler.	Comprobar que el cable de conexión entra en la bomba y el controler está bien fijado por ambos extremos y no está interrumpido. Apretar dos veces el pulsador START para volver a poner en marcha la bomba.
PUMP WAITING INTERLOCK	Está activa la señal de interlock presente en el conector P1 a causa de la interrupción del cortocircuito entre el pin 3 y el pin 8 del conector J1, o a causa de la apertura de la señal de interlock externo.	Eliminar el cortocircuito entre el pin 3 y el pin 8 del conector J1, o cerrar la señal de interlock exterior.
FAULT: OVERTIME SX	Durante la puesta en marcha de la bomba en el modo "soft start" la bomba no ha alcanzado la velocidad prevista a cada paso antes de 15 minutos. (X puede valer de 0 a 9 e indica el paso no superado).	Comprobar que el sistema no presenta pérdidas. Apretar dos veces el pulsador START para volver a poner en marcha la bomba.
FAULT: PUMP OVERTEMP.	La temperatura del rodamiento superior o de la bomba ha superado los 60 °C.	Esperar a que la temperatura vuelva por debajo del umbral. Apretar dos veces el pulsador START para volver a poner en marcha la bomba.
FAULT: CONTROLLER OVERTEMPERATURE	La temperatura del transformador del controler ha superado los 90 °C.	Esperar a que la temperatura vuelva por debajo del umbral. Apretar dos veces el pulsador START para volver a poner en marcha la bomba.
FAULT: TOO HIGH LOAD	Durante el funcionamiento normal (tras la fase de puesta en marcha) la corriente absorbida por la bomba es superior a la programada (1,5 A).	Comprobar que el rotor de la bomba tiene la posibilidad de girar libremente. Apretar dos veces el pulsador START para volver a poner en marcha la bomba.
FAULT: SHORT CIRCUIT	Durante el funcionamiento normal (tras la fase de puesta en marcha) la conexión de salida está en cortocircuito (corriente de salida más 2,2 A).	Comprobar las conexiones entre la bomba y el controler. Apretar dos veces el pulsador START para volver a poner en marcha la bomba.
SYSTEM OVERRIDE	La bomba ha sido parada por una señal de emergencia procedente de un contacto remoto.	Desenchufar el cable de alimentación del controler y corregir la causa de la emergencia. Volver a conectar el cable de alimentación y apretar dos veces el pulsador START para volver a poner en marcha la bomba.
OVERVOLTAGE	Se ha producido una avería en la sección de alimentación del controler o el controler ha recibido una señal espurio.	Apertar dos veces el pulsador START para volver a poner en marcha la bomba. Si el mensaje se vuelve a presentar dirigirse a Varian para el mantenimiento.
CONTROLLER FAILURE	Interrupción del fusible sobre el secundario de potencia.	Contactar Varian para el Mantenimiento.

INFORMAÇÕES GERAIS

Esta aparelhagem destina-se ao uso profissional. O utilizador deve ler atentamente o presente manual de instruções e todas as informações adicionais fornecidas pela Varian antes de utilizar a aparelhagem. A Varian não se responsabiliza pela inobservância total ou parcial das instruções, pelo uso indevido por parte de pessoas não treinadas, por operações não autorizadas ou pelo uso contrário às normas nacionais específicas.

Os controllers da série Turbo-V 70 são conversores de frequência, controlados por um microprocessador, realizados com componentes em estado sólido e com capacidade de autodiagnóstico e autoprotecção.

Os controllers comandam as bombas da série Turbo-V 70 (com um processo subdividido em dez passos) durante a fase de activação, controlando a tensão e a corrente em relação à velocidade atingida pela bomba.

Incorporam todos os circuitos necessários para o funcionamento automático das bombas da série Turbo-V 70. Através de um conector auxiliar estão disponíveis os comandos para a activação e a paragem da bomba por controlo remoto, os sinais que indicam o estado operativo da bomba, os comandos para a activação e a paragem da bomba de pré-vácuo, os sinais de bloqueio (para interruptores de pressão, interruptores de controlo do fluxo de água, etc.). Nos parágrafos seguintes estão descritas todas as informações necessárias para garantir a segurança do operador durante o uso da aparelhagem. Informações pormenorizadas são fornecidas no apêndice "Technical Information".

Este manual utiliza as seguintes convenções:



PERIGO!

As mensagens de perigo chamam a atenção do operador para um procedimento ou uma prática específica que, se não efectuada correctamente, pode provocar graves lesões pessoais.



ATENÇÃO!

As mensagens de atenção são visualizadas antes de procedimentos que, se não observados, podem causar danos à aparelhagem.

NOTA

As notas contêm informações importantes destacadas do texto.

ARMAZENAGEM

Durante o transporte e a armazenagem dos controllers, devem ser satisfeitas as seguintes condições ambientais:

- temperatura: de -20 °C a + 70 °C
- humidade relativa: 0 - 95% (não condensante)

PREPARAÇÃO PARA A INSTALAÇÃO

O controller é fornecido numa embalagem protectora especial; se apresentarem sinais de danos, que poderiam verificar-se durante o transporte, entrar em contacto com o escritório de vendas local.

Durante a retirada da embalagem, tomar muito cuidado para não deixar cair o controller e para não submetê-lo a choques. Não depositar a embalagem no meio ambiente. O material é completamente reciclável e responde à directrizes CEE 85/399 para a protecção do meio ambiente.

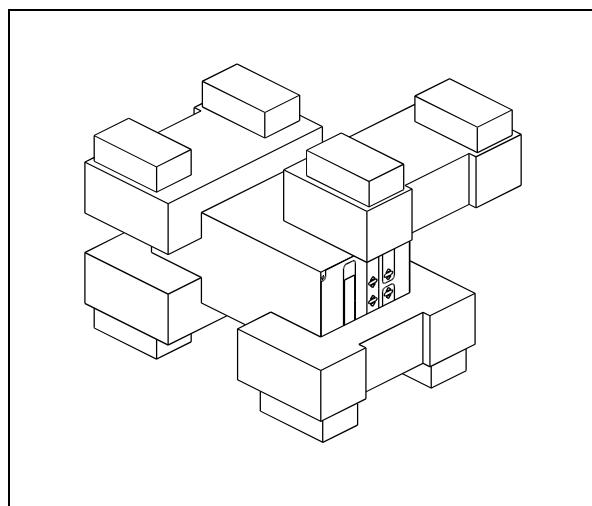

*Embalagem dos controllers
969-9405 e 969-9505*

Cada controller chega à Varian predisposto para uma determinada tensão de alimentação:

- o modelo 969-9405 para 220 Vac
- o modelo 969-9505 para 120 Vac

Caso seja necessário mudar a tensão de alimentação, executar o procedimento a seguir:

- Desligar o cabo de alimentação do painel posterior do controller.
- Verificar, no módulo de entrada de tensão, a tensão de alimentação predisposta.
- Extrair o módulo de selecção de tensão com fusível utilizando uma chave de parafusos.
- Seleccionar a tensão de alimentação desejada e, a seguir, reinstalar com força o módulo na sua sede.
- Verificar se foi seleccionada a tensão correcta e, a seguir, ligar novamente o cabo de alimentação.

INSTALAÇÃO



PERIGO!

O controller é fornecido com um cabo de alimentação de três fios com uma tomada de tipo aprovado a nível internacional. Utilizar sempre este cabo de alimentação e inserir a tomada com uma ligação de massa adequada para evitar descargas eléctricas. No interior do controller desenvolvem-se altas tensões que podem provocar graves danos ou a morte. Antes de efectuar qualquer operação de instalação ou manutenção do controller, desligar a tomada de alimentação.

NOTA

O controller pode ser instalado numa mesa ou no interior de um rack específico. Em todo caso é necessário que o ar de refrigeração possa circular livremente ao redor da aparelhagem. Não instalar e/ou utilizar o controller em ambientes expostos a agentes atmosféricos (chuva, gelo, neve), poeiras, gases agressivos ou em ambientes explosivos ou com elevado risco de incêndio.

Durante o funcionamento é necessário que sejam respeitadas as seguintes condições ambientais:

- temperatura: de 0 °C a + 40 °C
- humidade relativa: 0 - 95% (não condensante).

Para a ligação do controller à respectiva bomba, utilizar o cabo específico do próprio controller.

NOTA

Os controllers modelo 969-9405 e 969-9505 possuem o cabo de alimentação à bomba fixado ao painel traseiro do próprio controller.

Para as outras ligações e a instalação dos acessórios opcionais, ver a secção "Technical Information".

UTILIZAÇÃO

Neste parágrafo são descritos os principais procedimentos operativos. Para maiores detalhes e para procedimentos que envolvem ligações ou peças opcionais, consultar o parágrafo "Use" do apêndice "Technical Information".

Antes de usar o controller efectuar todas as ligações eléctricas e pneumáticas e consultar o manual da bomba ligada.



PERIGO!

Para evitar danos às pessoas e à aparelhagem, caso a bomba esteja apoiada numa mesa, certificar-se que esteja estável. Nunca activar a bomba se o flange de entrada não está ligado ao sistema ou não está fechado com o flange de fecho.

NOTA

O conector de fecho J1 deve estar ligado com a sua ponte se não é efectuada nenhuma ligação externa. A bomba de pré-vácuo e a bomba Turbo-V podem ser ligadas simultaneamente.

Comandos, Indicadores e Conectores do Controller

A seguir, estão ilustrados o painel de comando do Controller e os painéis de interconexão. Para maiores detalhes, consultar a secção "Technical Information".



Painel frontal do Controller
969-9405, 969-9505

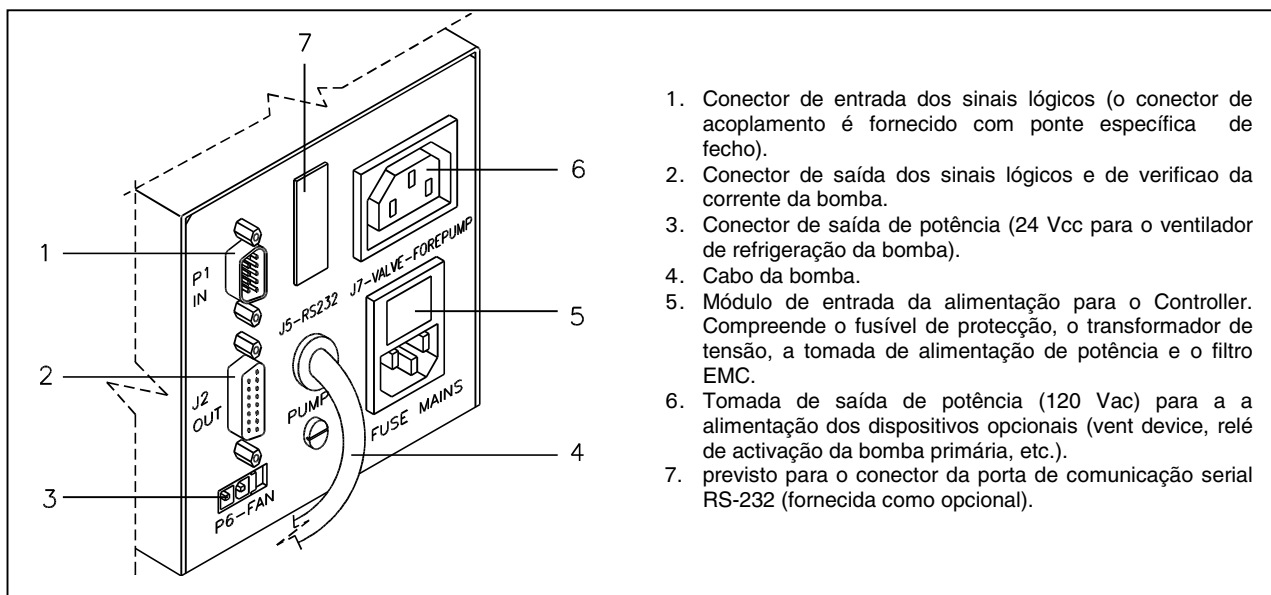

1. Conector de entrada dos sinais lógicos (o conector de acoplamento é fornecido com ponte específica de fecho).
2. Conector de saída dos sinais lógicos e de verificação da corrente da bomba.
3. Conector de saída de potência (24 Vcc para o ventilador de refrigeração da bomba).
4. Cabo da bomba.
5. Módulo de entrada da alimentação para o Controller. Compreende o fusível de protecção, o transformador de tensão, a tomada de alimentação de potência e o filtro EMC.
6. Tomada de saída de potência (120 Vac) para a alimentação dos dispositivos opcionais (vent device, relé de activação da bomba primária, etc.).
7. previsto para o conector da porta de comunicação serial RS-232 (fornecida como opcional).

Painel posterior dos Controlers 969-9405 e 969-9505

PROCEDIMENTOS DE USO

Acendimento do Controller

Para ligar o controller é suficiente inserir o cabo de alimentação na tomada de rede.

Activação da bomba

Para activar as bombas é necessário premer o botão START do painel frontal.

Paragem da bomba

Para parar a bomba é necessário premer o botão STOP do painel frontal.

MANUTENÇÃO

Os controllers da série Turbo-V 70 não requerem qualquer manutenção. Todas as operações devem ser efectuadas por pessoal autorizado.

Em caso de defeito é possível utilizar o serviço de reparação Varian ou o "Varian advanced exchange service", que permite obter um controller regenerado que substitua o controller com defeito.

Caso um controller deva ser destruído, proceder à sua eliminação respeitando as normas nacionais específicas.



PERIGO!

Antes de efectuar qualquer operação no controller, desligar o conector de alimentação.

MENSAGENS DE ERRO

Em alguns casos de defeitos, os circuitos de autodiagnóstico do controller apresentam mensagens de erro relacionadas na tabela abaixo.

MENSAGEM	DESCRIÇÃO	ACÇÃO CORRECTIVA
CHECK CONNECTION TO PUMP	Mau funcionamento na ligação entre a bomba e o controller.	Verificar se o cabo de ligação entre a bomba e o controller está bem fixado em ambas as extremidades e não está interrompido. Premer duas vezes o botão START para reactivar a bomba.
PUMP WAITING INTERLOCK	É activado o sinal de interlock existente no conector P1 devido à interrupção do curto circuito entre o pin 3 e o pin 8 do conector J1 ou devido à abertura do sinal de interlock externo.	Restabelecer o curto circuito entre o pin 3 e o pin 8 do conector J1 ou fechar o sinal de interlock externo.
FAULT: OVERTIME SX	Durante o accionamento da bomba no modo "soft start", a bomba não atingiu a velocidade prevista a cada passo em 15 minutos. (X pode valer de 0 a 9 e indica o passo não superado).	Verificar se o sistema não apresenta perdas. Premer duas vezes o botão START para reactivar a bomba.
FAULT: PUMP OVERTEMP.	A temperatura do rolamento superior ou da bomba superou os 60 °C.	Aguardar até que a temperatura volte ao limite estabelecido. Premer duas vezes o botão START para reactivar a bomba.
FAULT: CONTROLLER OVERTEMPERATURE	A temperatura do transformador do controller superou os 90 °C.	Aguardar até que a temperatura volte ao limite estabelecido. Premer duas vezes o botão START para reactivar a bomba.
FAULT: TOO HIGH LOAD	Durante o funcionamento normal (após a fase de accionamento) a corrente absorvida pela bomba é maior do que a programada (1,5 A).	Verificar se o rotor da bomba pode rodar livremente. Premer duas vezes o botão START para reactivar a bomba.
FAULT: SHORT CIRCUIT	Durante o funcionamento normal (após a fase de accionamento) a conexão de saída está em curto circuito (corrente de saída maior que 2,2 A).	Verificar as ligações entre a bomba e o controller. Premer duas vezes o botão START para reactivar a bomba.
SYSTEM OVERRIDE	A bomba parou por um sinal de emergência proveniente de um contacto remoto.	Remover o cabo de alimentação do controller e corrigir a causa da emergência. Ligar novamente o cabo de alimentação e premer duas vezes o botão START para reactivar a bomba.
OVERVOLTAGE	Verificou-se um defeito na secção de alimentação do controller, ou o controller recebeu um sinal falso.	Premar duas vezes o botão START para reactivar a bomba. Se a mensagem se reapresentar, dirigir-se à Varian para a manutenção.
CONTROLLER FAILURE	Interrupção fusível no secundário de potência.	Contactar a Varian para a manutenção.

ALGEMENE INFORMATIE

Deze apparatuur is bestemd voor beroepsmatig gebruik. De gebruiker wordt verzocht aandachtig deze handleiding en alle overige door Varian verstrekte informatie door te lezen alvorens het apparaat in gebruik te nemen. Varian acht zich niet aansprakelijk voor de gevolgen van het niet of gedeeltelijk in acht nemen van de aanwijzingen, onoordeelkundig gebruik door niet hiervoor opgeleid personeel, reparaties waarvoor geen toestemming is verkregen of gebruik in strijd met de specifieke nationale wetgeving. De controllers van de Turbo-V 70 serie zijn frequentieomzetter die gestuurd worden door een microprocessor, zijn gemaakt van halfgeleider-elementen en zijn in staat om zelfdiagnose en zelfbescherming uit te voeren. De controllers sturen de pompen van de serie Turbo-V 70 (met een proces bestaande uit tien stappen) tijdens de startfase, en controleren hierbij de spanning en de stroom in verhouding tot de door de pomp bereikte snelheid. De controllers zijn van circuits voorzien die noodzakelijk zijn voor de automatische werking van de pompen van de serie Turbo-V 70.

Via een hulpconnector zijn de sturingen voor het op afstand starten en stoppen van de pomp beschikbaar, de signalen die de bedrijfstoestand van de pomp aangeven, de sturingen voor het starten en stoppen van de pre-vacuumpomp, blokkeersignalen (voor druschakelaars, regelschakelaars van de waterstroom, enz.). In de volgende paragrafen is alle informatie vermeld om de veiligheid van de operator tijdens het gebruik van de apparatuur te verzekeren. Gedetailleerde informatie is te vinden in de bijlage "Technical information".

Deze handleiding hanteert de volgende symbolen:



Bij dit symbool staat tekst die de aandacht van de operator vestigt op een speciale procedure of methode die, indien niet correct uitgevoerd, ernstig lichamelijk letsel kan veroorzaken.



Bij dit symbool staat tekst met procedures die, indien niet opgevolgd, schade aan apparatuur kunnen veroorzaken.

OPMERKING

De opmerkingen bevatten belangrijke informatie die uit de tekst is gelicht.

OPSLAG

Tijdens het transport en de opslag van de controllers moeten de volgende omgevingscondities aanwezig zijn:

- temperatuur: van -20 °C tot +70 °C
- relatieve vochtigheid: 0 - 95% (niet condenserend)

VOORBEREIDING VOOR INSTALLATIE

De controller wordt in een speciale beschermende verpakking geleverd; als er schade wordt geconstateerd die tijdens het transport veroorzaakt zou kunnen zijn, meteen contact opnemen met het plaatselijke verkoopkantoor.

Zorg er bij het uitpakken voor dat de controller niet kan vallen of stoten te verduren krijgt.

Laat de verpakking niet ergens buiten achter. Het verpakkingsmateriaal is volledig recyclebaar en voldoet aan de EEG milieurechtlijn 85/399.

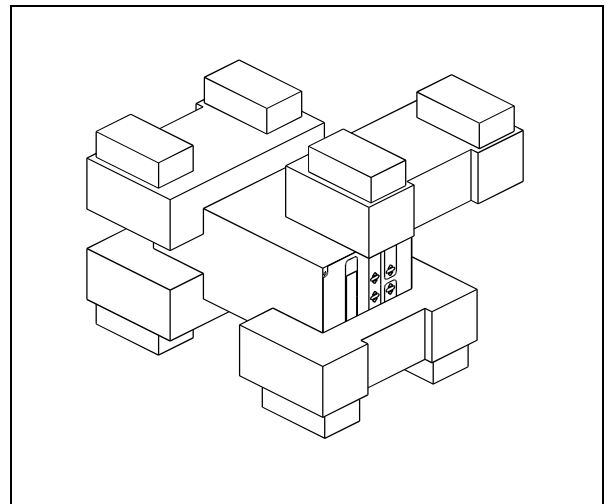

*Verpakking van de controllers
969-9405 en 969-9505*

Varian heeft elke controller voorbereid voor een bepaalde voedingsspanning:

- het model 969-9405 voor 220 Vac
- het model 969-9505 voor 10 Vac

Mocht het nodig zijn de voedingsspanning te veranderen, de volgende procedure volgen:

- Koppel de voedingskabel van het achterpaneel van de controller af.
- Controleer op de ingangsmodule van de spanning de ingestelde voedingsspanning.
- Verwijder de module voor spanningskeuze met zekering met behulp van een kleine schroevendraaier.
- Kies de gewenste voedingsspanning en breng de module weer in zijn zitting aan.
- Controleer of de juiste spanning is gekozen en sluit de voedingskabel weer aan.

INSTALLATIE



GEVAAR!

De controller is voorzien van een voedingskabel met drie draden en een stekker van het internationaal goedgekeurde type. Gebruik altijd deze voedingskabel en steek de stekker in een geaard contactstop om elektrische ontladingen te voorkomen.

In de controller ontwikkelen zich hoge spanningen die zware beschadigingen of de dood kunnen veroorzaken. Alvorens installatie- of onderhoudswerkzaamheden uit te voeren, de controller van de contactstop afkoppelen.

OPMERKING

De controller kan op een tafel of in een speciaal rack worden geïnstalleerd. In ieder geval moet de koellucht vrij rondom het apparaat kunnen circuleren. De controller mag niet geïnstalleerd en/of gebruikt worden in ruimten die blootgesteld zijn aan de weersomstandigheden (regen, vorst, sneeuw), stof, agressieve gassen, of in ruimten met explosiegevaar of zeer hoog brandgevaar.

Tijdens de werking moeten de volgende omgevingscondities aanwezig zijn:

- temperatuur: van 0 °C tot +40 °C
- relatieve vochtigheid: 0 - 95% (niet condenserend).

Gebruik voor aansluiting van de controller op de pomp de speciale kabel van de controller.

OPMERKING

De verbindingkabel van de controller aan de pomp van de modellen 969-9405 en 969-9505 is op het achterpaneel van de controller bevestigd.

Voor de overige aansluitingen en de installatie van de accessoires wordt verwezen naar het hoofdstuk "Technical Information".

GEBRUIK

In deze paragraaf worden de voornaamste bedieningswijzen uitgelegd. Voor meer informatie of procedures die aansluitingen of speciale opties betreffen wordt verwezen naar de paragraaf "Use" van de bijlage "Technical Information".

Breng, alvorens de controller in gebruik te nemen, alle elektrische en pneumatische aansluitingen tot stand en raadpleeg hiervoor de handleiding van de aan te sluiten pomp.



GEVAAR!

Indien de pomp op een tafel is geplaatst, controleren of deze stabiel staat om letsel aan personen en schade aan het apparaat te voorkomen. Laat de pomp nooit werken zonder dat de ingangsfens aan het systeem is gekoppeld of de afsluitfens is gesloten.

OPMERKING

De connector J1 moet met zijn jumper aangesloten blijven als geen externe aansluiting tot stand wordt gebracht. De pre-vacuümpomp en de Turbo-V pomp mogen beide gelijktijdig ingeschakeld zijn.

Bedieningsorganen, controlelampjes en connectoren van de controller

Hier volgt de beschrijving van het bedieningspaneel van de controller en van de doorverbindingspanelen. Voor meer informatie wordt verwezen naar het hoofdstuk "Technical Information".

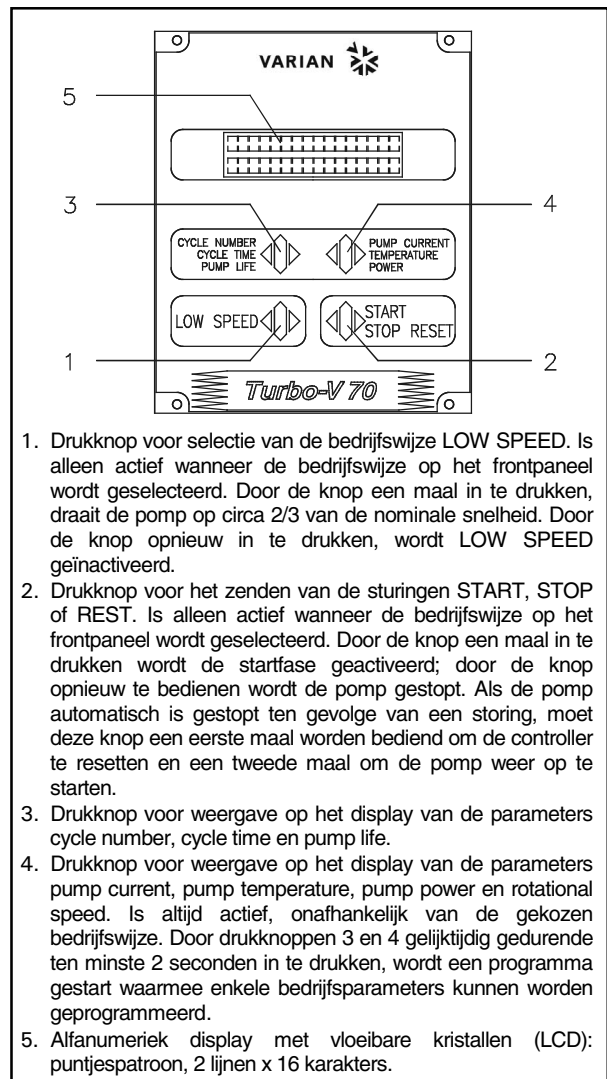

1. Drukknop voor selectie van de bedrijfswijze LOW SPEED. Is alleen actief wanneer de bedrijfswijze op het frontpaneel wordt geselecteerd. Door de knop een maal in te drukken, draait de pomp op circa 2/3 van de nominale snelheid. Door de knop opnieuw in te drukken, wordt LOW SPEED geïnactiveerd.
2. Drukknop voor het zenden van de sturingen START, STOP of REST. Is alleen actief wanneer de bedrijfswijze op het frontpaneel wordt geselecteerd. Door de knop een maal in te drukken wordt de startfase geactiveerd; door de knop opnieuw te bedienen wordt de pomp gestopt. Als de pomp automatisch is gestopt ten gevolge van een storing, moet deze knop een eerste maal worden bediend om de controller te resetten en een tweede maal om de pomp weer op te starten.
3. Drukknop voor weergave op het display van de parameters cycle number, cycle time en pump life.
4. Drukknop voor weergave op het display van de parameters pump current, pump temperature, pump power en rotational speed. Is altijd actief, onafhankelijk van de gekozen bedrijfswijze. Door drukknoppen 3 en 4 gelijktijdig gedurende ten minste 2 seconden in te drukken, wordt een programma gestart waarmee enkele bedrijfsparameters kunnen worden geprogrammeerd.
5. Alfnumeriek display met vloeibare kristallen (LCD): puntjespatroon, 2 lijnen x 16 karakters.

*Frontpaneel van de Controllers
969-9405, 969-9505*

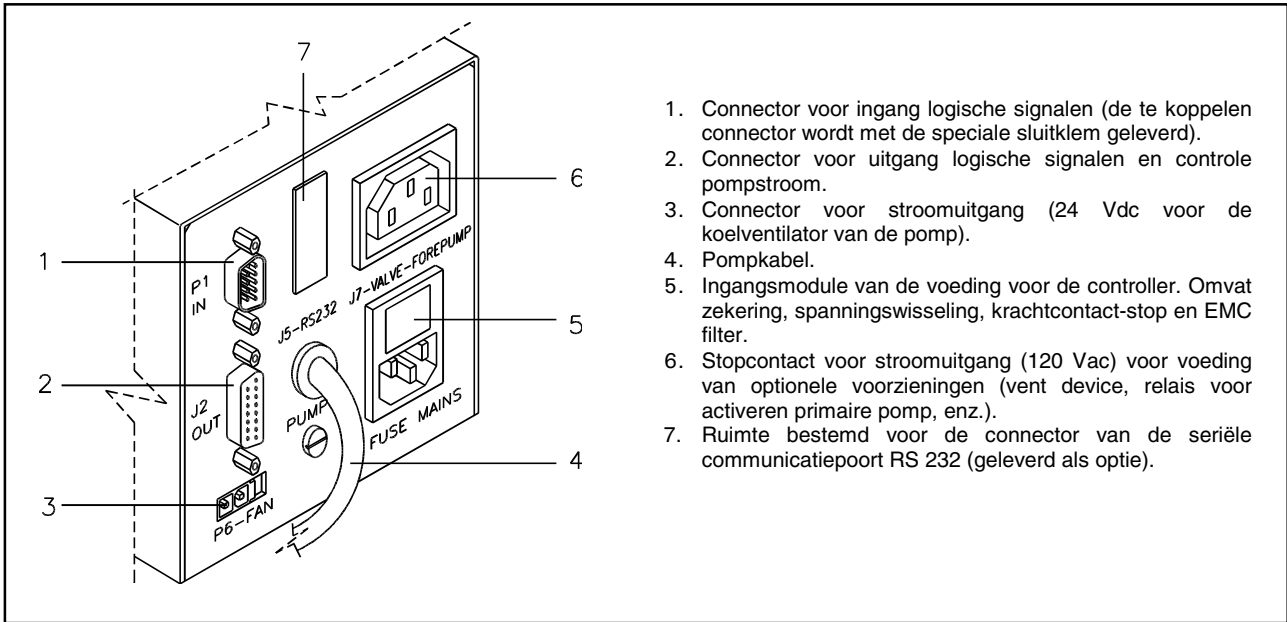

Achterpaneel van de controllers 969-9405 en 969-9505

1. Connector voor ingang logische signalen (de te koppelen connector wordt met de speciale sluitklem geleverd).
2. Connector voor uitgang logische signalen en controle pompstroom.
3. Connector voor stroomuitgang (24 Vdc voor de koelventilator van de pomp).
4. Pompkabel.
5. Ingangsmodule van de voeding voor de controller. Omvat zekering, spanningswisseling, krachtcontact-stop en EMC filter.
6. Stopcontact voor stroomuitgang (120 Vac) voor voeding van optionele voorzieningen (vent device, relais voor activeren primaire pomp, enz.).
7. Ruimte bestemd voor de connector van de seriële communicatiepoort RS 232 (geleverd als optie).

GEBRUIKSPROCEDURES

Inschakelen van de controller

Om de controller in te schakelen, de voedingskabel in de netcontactdoos inbrengen.

Starten van de pomp

Voor het starten van de pomp de START knop op het frontpaneel bedienen.

Stoppen van de pomp

Voor het stoppen van de pomp de STOP knop op het frontpaneel bedienen.

ONDERHOUD

De controllers van de serie Turbo-V 70 zijn onderhoudsvrij. Eventuele werkzaamheden moeten door bevoegd personeel worden uitgevoerd.

In geval van storing is het mogelijk om de reparatiedienst van Varian of de "Varian advanced exchange service" in te schakelen: zo krijgt men een ruilcontroller ter vervanging van de defecte controller.

Mocht de controller gesloopt worden, ga dan overeenkomstig de specifieke nationale wetgeving te werk.



GEVAAR!

Alvorens werkzaamheden aan de controller uit te voeren, de voedingskabel afkoppelen.

FOUTMELDINGEN

In geval van storingen wekt het zelfdiagnose-circuit van de controller enkele foutmeldingen op die in de volgende tabel zijn omschreven.

BOODSCHAP	OMSCHRIJVING	REMEDIE
CHECK CONNECTION TO PUMP	Foutieve verbinding tussen pomp en controller.	Controleren of de verbindingkabel tussen pomp en controller aan beide uiteinden goed bevestigd is en geen onderbrekingen vertoont. Bedien twee maal de START-knop om de pomp weer op te starten.
PUMP WAITING INTERLOCK	Het interlock-sigitaal op connector P1 is actief wegens onderbreking van de kortsluiting tussen pin 3 en pin 8 van connector J1 of wegens het openen van het externe interlock-sigitaal.	Herstel de kortsluiting tussen pin 3 en pin 8 van connector J1 of sluit het externe interlock-sigitaal.
FAULT: OVERTIME SX	Tijdens de "soft start" van de pomp, heeft de pomp niet binnen 15 minuten de snelheid die voor elke stap is voorzien bereikt (X kan waarde tussen 0 en 9 aannemen en geeft de niet overschreden stap aan).	Controleer of het systeem geen lekkage vertoont. Bedien twee maal de START-knop om de pomp weer op te starten.
FAULT: PUMP OVERTEMP.	De temperatuur van het bovenste pomplager bedraagt meer dan 60 °C.	Wacht tot de temperatuur weer onder de drempelwaarde is gezakt. Bedien twee maal de START-knop om de pomp weer op te starten.
FAULT: CONTROLLER OVERTEMPERATURE	De temperatuur van de transformator van de controller bedraagt meer dan 90 °C.	Wacht tot de temperatuur weer onder de drempelwaarde is gezakt. Bedien twee maal de START-knop om de pomp weer op te starten.
FAULT: TOO HIGH LOAD	Tijdens normale werking (na startfase) ligt de door de pomp geabsorbeerde stroom hoger dan de geprogrammeerde waarde (1,5 A).	Controleer of de pomprotor vrij kan draaien. Bedien twee maal de START-knop om de pomp weer op te starten.
FAULT: SHORT CIRCUIT	Tijdens normale werking (na startfase) is de uitgangsverbinding in kortsluiting (uitgangsstroom groter dan 2,2 A).	Controleer de verbindingen tussen pomp en controller. Bedien twee maal de START-knop om de pomp weer op te starten.
SYSTEM OVERRIDE	De pomp is stilgelegd door een noodsignaal afkomstig van een afstandscontact.	Koppel de voedingskabel van de controller af en elimineer de oorzaak van de noodstop. Sluit de voedingskabel weer aan en bedien twee maal de START-knop om de pomp weer op te starten.
OVERVOLTAGE	Er is een storing opgetreden in de voedingssectie van de controller of de controller heeft een stoorsignaal ontvangen.	Bedien twee maal de START-knop om de pomp weer op te starten. Als de melding weer verschijnt zich voor onderhoud tot Varian wenden.
CONTROLLER FAILURE	Doorgebrande zekering in secundaire hoofdstroomkring.	Zich tot Varian voor het onderhoud wenden.

GENEREL INFORMATION

Dette materiel er beregnet til professionel anvendelse. Brugeren bør læse denne brugsanvisning og anden yderligere information fra Varian, før udstyret anvendes. Varian tager ikke ansvar for skader helt eller delvis som følge af tilsidesættelse af disse instruktioner, fejlagtig brug af personer uden tilstrækkelig kendskab, ukorrekt anvendelse af udstyret eller håndtering, der strider imod gældende lokale regler. Styreenhederne i Turbo-V 70 serien er mikroprocessorstyrede frekvens-omformere, der består af komponenter med fast tilstand.

Styreenhederne er udstyrede med selvdiagnose- og selvbeskyttelsesfunktioner. Styreenhederne kontrollerer pumperne i Turbo-V 70 serien (med en ti-trins-proces) i forbindelse med start. Spænding og strøm reguleres i forhold til pumpens opnåede hastighed.

Styreenhederne omfatter alle midler, der kræves for automatisk drift af pumperne i Turbo-V 70 serien.

En hjælpekontakt forsyner kontrol til fjernstart og -stop af pumpen, signaler om pumpens tilstand, kontrol til start og stop af førvakuum-pumpen, blokeringssignaler (til tryk- og vandføringsafbrydere, osv.).

De følgende afsnit indeholder al information der behøves, for at garantere operatørens sikkerhed under anvendelsen. Detaljeret information findes i bilaget "Technical Information".

I brugsanvisningen anvendes følgende standardrubrikker:



ADVARSEL !

Advarselsmeddelelserne informerer operatøren om, at en speciel procedure eller en vis type arbejde skal udføres præcist efter anvisningerne. I modsat fald er der risiko for svære personskader.



VIKTIGT !

Denne advarselsmeddelelse vises før procedurer, der skal følges nøje for ikke at risikere maskinskader.

BEMÆRK

Dette gør opmærksom på vigtig information i teksten.

OPBEVARING

Følgende krav til omgivelsesforholdene gælder ved transport og opbevaring af styreenheden:

- temperatur: fra -20 °C til +70 °C
- relativ luftfugtighed: 0 - 95%
(ikke kondenserende)

FORBEREDELSE FØR INSTALLATION

Styreenheden leveres i en speciel beskyttende emballage. Kontakt den lokale forhandler, hvis emballagen viser tegn på skader, der kan være opstået under transporten. Sørg for at styreenheden ikke tabes eller udsættes for stød ved udpakningen. Smid ikke emballagen ud. Materialet kan genbruges 100% og opfylder EU-direktiv 85/399 om miljøbeskyttelse.

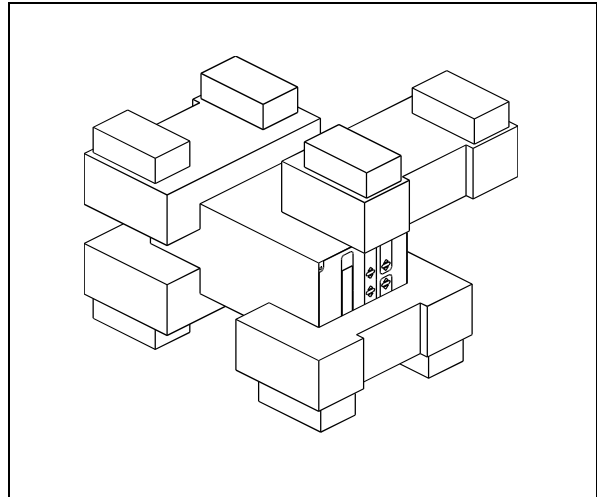

Styreenhedens emballage
969-9405 og 969-9505

Styreenheden leveres fra Varian forindstillet til en vis strømforsyning:

- modellen 969-9405 til 220 V vekselstrøm
- modellen 969-9505 til 120 V vekselstrøm

Hvis strømforsyningen skal ændres, gå således til værks:

- Frakobel strømkablet på styreenhedens bagside.
- Kontrollér hvilken spænding, der er installeret på spændingsindgangsmodulet.
- Tag spændingsindgangsmodulet og tilhørende sikring ud med en lille skruetrækker.
- Vælg ønskede driftsspænding og sæt modulet og sikringen godt fast igen.
- Kontrollér at den valgte spænding er korrekt. Tilslut strømkablet.

INSTALLATION

**ADVARSEL !**

Styreenheden leveres med strømkabel med tre ledere og godkendt stik efter internationale standarder. Anvend udelukkende det medleverede strømkabel. Stikket må kun tilsluttes et vægudtag med fungerende jordtilslutning, for at undgå elektriske stød. Spænding frembragt i styreenheden kan nå høje værdier og forårsage stor skade og dødsfald. Frakobel altid strømkablet, inden der udføres installations- eller vedligeholdelsesarbejde på styreenheden.

BEMÆRK

Styreenheden kan installeres på et bord eller et velegnet stativ. I begge tilfælde skal der være plads nok til, at luft kan cirkulere frit omkring apparatet. Installér og anvend ikke styreenheden i miljøer, der udsættes for påvirkninger fra atmosfæren (regn, sne, is), damp, aggressive gasser, og ligeledes ikke i eksplosivt eller brandfarligt miljø.

Følgende krav til omgivelserforholdene gælder ved drift:

- temperatur: fra 0 °C til +40 °C
- relativ luftfugtighed: 0 - 95% (ikke kondenserende)

Pumpen og styreenheden tilsluttes med det specielle kabel, der leveres med styreenheden.

BEMÆRK

Styreenheden model 969-9405 og 969-9505 leveres med kabel til tilslutning af pumpen, der er fastmonteret på styreenhedens bagside.

For øvrige tilslutninger og installation af tilbehør henvises til afsnittet "Technical Information".

ANVENDELSE

Dette afsnit beskriver de vigtigste driftsprocedurer. For en detaljeret beskrivelse samt procedurer, der involverer tilslutninger eller tilbehør, henvises til afsnittet "Use" i bilag "Technical Information".

Inden styreenheden anvendes, bør samtlige elektriske og pneumatiske tilslutninger udføres. Læs brugsanvisningen før pumpen tilsluttes.

**ADVARSEL !**

Sørg for, at pumpen står fast, hvis den er installeret på et bord. Dette er for at forebygge skader på apparatet og personer. Start aldrig pumpen, hvis pumpetilløbet ikke er tilsluttet systemet eller er blokeret.

BEMÆRK

Afbryderkontakten J1 skal forblive tilsluttet med aktuel bro, når der ikke udføres eksterne tilslutninger. Før-vakuumpumpen og Turbo-V-pumpen skal fungere samtidigt.

Kontroller, indikatorer og kontakter på styreenheden

Følgende beskriver manøvrepanelet til styreenheden samt tilslutningspanelerne.

For yderligere information henvises til bilag "Technical Information".

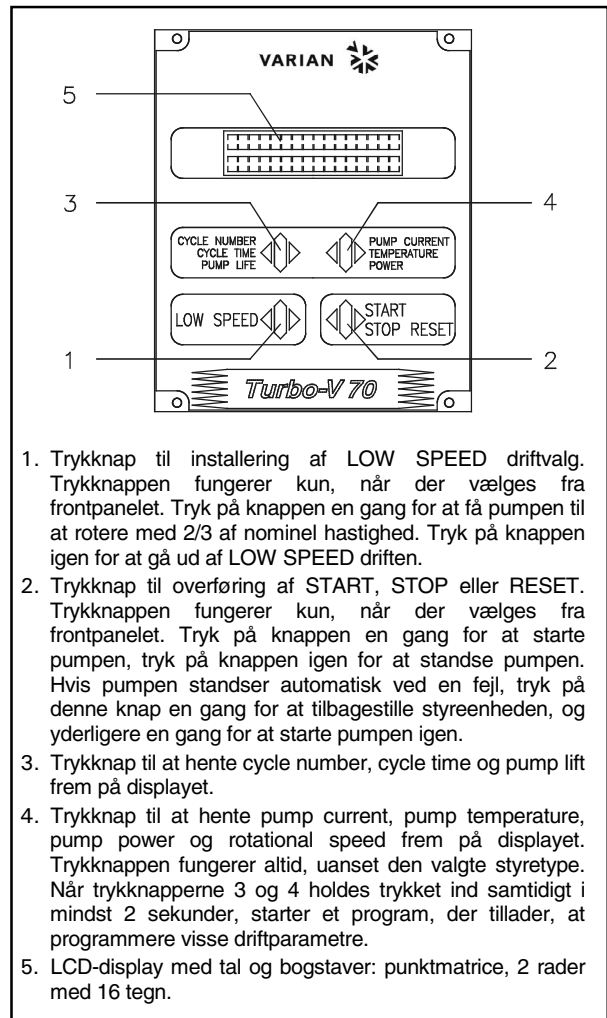

1. Trykknop til installering af LOW SPEED driftvalg. Trykknappen fungerer kun, når der vælges fra frontpanelet. Tryk på knappen en gang for at få pumpen til at rotere med 2/3 af nominal hastighed. Tryk på knappen igen for at gå ud af LOW SPEED driften.
2. Trykknop til overføring af START, STOP eller RESET. Trykknappen fungerer kun, når der vælges fra frontpanelet. Tryk på knappen en gang for at starte pumpen, tryk på knappen igen for at standse pumpen. Hvis pumpen standser automatisk ved en fejl, tryk på denne knap en gang for at tilbagestille styreenheden, og yderligere en gang for at starte pumpen igen.
3. Trykknop til at hente cycle number, cycle time og pump life frem på displayet.
4. Trykknop til at hente pump current, pump temperature, pump power og rotational speed frem på displayet. Trykknappen fungerer altid, uanset den valgte styretype. Når trykknapperne 3 og 4 holdes trykket ind samtidigt i mindst 2 sekunder, starter et program, der tillader, at programmere visse driftparametre.
5. LCD-display med tal og bogstaver: punktmatrix, 2 rader med 16 tegn.

Frontpanelet på Styreenheden
969-9405 og 969-9505

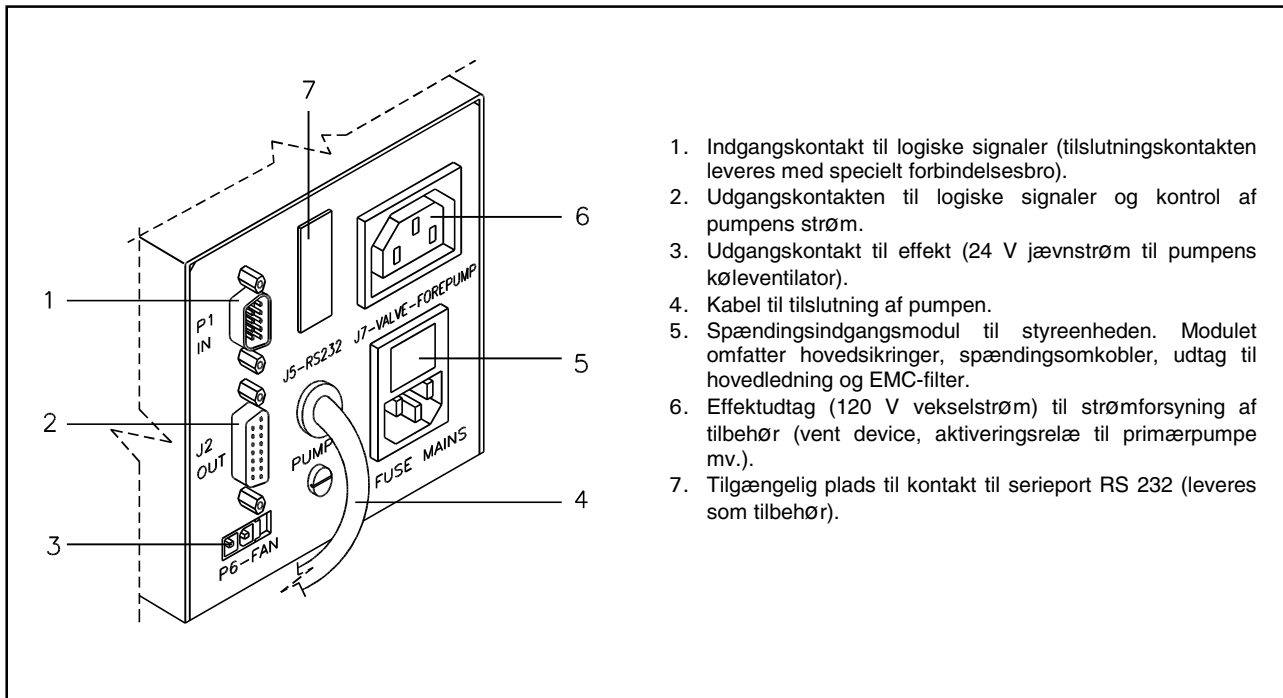

Bagpanelet på Styreenheden 969-9405 og 969-9505

1. Indgangskontakt til logiske signaler (tilslutningskontakten leveres med specielt forbindelsesbro).
2. Udgangskontakten til logiske signaler og kontrol af pumpens strøm.
3. Udgangskontakt til effekt (24 V jævnstrøm til pumpens køleventilator).
4. Kabel til tilslutning af pumpen.
5. Spændingsindgangsmodul til styreenheden. Modulet omfatter hovedsikringer, spændingsomkobler, udtag til hovedledning og EMC-filter.
6. Effektudtag (120 V vekselstrøm) til strømforsyning af tilbehør (vent device, aktiveringsrelæ til primærpumpe mv.).
7. Tilgængelig plads til kontakt til serieport RS 232 (leveres som tilbehør).

INSTRUKTION

Start af styreenheden

Styreenheden startes ved at sætte strømkablet i vægudtaget.

Start af pumpen

Pumpen startes ved at trykke på START-trykknappen.

Stop af pumpen

Pumpen stopper ved at trykke på STOP-trykknappen på frontpanelet.

VEDLIGEHOLDELSE

Styreenhederne i Turbo-V 70-serien behøver ikke nogen vedligeholdelse. Ethvert indgreb på pumpen skal foretages af autoriseret personale.

Hvis pumpen går i stykker, kan man benytte sig af Varians reparations-service eller Varian udvekslingsservice, hvor man kan få en repareret pumpe i bytte for den, der er gået i stykker.

**ADVARSEL !**

Inden der foretages noget som helst indgreb på styreenheden, skal strømmen først afbrydes.

Skrotning af pumpen skal foregå i overensstemmelse med det pågældende lands særlige love.

FEJLMEDDELELSER

Når visse fejl opstår, viser styreenheden ved selvdiagnose aktuelle fejl på displayet. De mulige meddelelser listes i følgende tabel.

MEDDELELSE	BESKRIVELSE	KONTROL
CHECK CONNECTION TO PUMP	Tilslutning mellem pumpe og styreenhed er defekt.	Kontrollér at tilslutningskabel mellem pumpe og styreenhed er korrekt monteret samt at ingen afbrydninger forekommer. Tryk to gange på START for at starte pumpen igen.
PUMP WAITING INTERLOCK	Interlocksignalet findes på kontakt P1 p.g.a. kortslutning mellem stift 3 og stift 8 i kontakten J1 eller p.g.a. at det eksterne interlocksignal er åbent.	Tilbagestil kortslutningen mellem stift 3 og stift 8 på kontakt J1 eller sluk for det eksterne interlocksignal.
FAULT: OVERTIME SX	Ved opstart af pumpen med "blød start" har pumpen ikke nået den korrekte hastighed for hvert trin indenfor 15 minutter (X kan gælde 0 til 9 og angiver hvilket trin, der ikke blev gennemført).	Kontrollér om systemet er utæt. Tryk to gange på START, for at starte pumpen igen.
FAULT: PUMP OVERTEMP.	Temperaturen på det øverste leje eller pumpen overskrider 60 °C.	Vent på at temperaturen falder til under tærskelværdi. Tryk to gange på START for at starte pumpen igen.
FAULT: CONTROLLER OVERTEMPERATURE	Temperaturen på styreenhedens transformator overskrider 90 °C.	Vent på at temperaturen falder til under tærskelværdi. Tryk to gange på START for at starte pumpen igen.
FAULT: TOO HIGH LOAD	Under normal drift (efter startfasen) forbruger pumpen en større effekt end den programmerede værdi (1,5 A).	Kontrollér om pumpens rotor kan rotere frit. Tryk to gange på START for at starte pumpen igen.
FAULT: SHORT CIRCUIT	Under normal drift (efter startfasen) er udgangseffekten kortsluttet (udgangsstrømmen højere end 2,2 A).	Kontrollér forbindelserne mellem pumpe og styreenhed. Tryk to gange på START for at starte pumpen igen.
SYSTEM OVERRIDE	Pumpen er blevet standset af et nødstopsignal fra en fjernkontakt.	Frakobel styreenhedens strømkabel og kontrollér årsagen til nødstopet. Sæt derefter strømkablet i. Tryk to gange på START, for at starte pumpen igen.
OVERVOLTAGE	Der er opstået fejl i styreenhedens fødespænding eller styreenheden har fået et falsk signal.	Tryk to gange på START-knappen for at starte pumpen igen. Hvis meddelelsen kommer igen tag kontakt med Varian for nødvendig vedligeholdelse.
CONTROLLER FAILURE	Afbrydelse af sikring i sekundært effektkredsløb.	Ret henvendelse til Varian vedrørende vedligeholdelse.

ALLMÄN INFORMATION

Utrustningen är avsedd för yrkesmässig användning. Användaren bör läsa denna bruksanvisning, samt övrig dokumentation från Varian före användning av utrustningen. Varian tar inget ansvar för skador som helt eller delvis orsakats av åsidosättande av instruktionerna, olämplig användning av person utan tillräcklig kunskap, obehörigt bruk av utrustningen eller hantering som strider mot gällande lokala föreskrifter.

Styrenheterna i Turbo-V 70 serien är mikroprocessorstyrda frekvensomvandlare som består av komponenter med fast tillstånd. Styrenheterna är försedda med självdiagnos- och självskyddsfunktion. Styrenheterna kontrollerar pumparna i Turbo-V 70 serien (med en tiostegs-process) i samband med start. Spänning och ström regleras i förhållande till pumpens uppnådda hastighet.

Styrenheterna omfattar alla kretsar som behövs för automatisk drift av pumparna i Turbo-V 70 serien.

En hjälpkontakt erbjuder kontroller för fjärrstart och fjärrstopp av pumpen, signaler för pumpens tillstånd, kontroller för start och stopp av förvakuum-pumpen, blockeringssignaler (för tryckvakter, kontrollbrytare för vattenflöde osv). De följande avsnitten innehåller all information som behövs för att garantera operatörens säkerhet under driften. Detaljerade uppgifter finns i bilagan "Technical information".

I bruksanvisningen används följande standardrubriker:



VARNING!

Varningsmeddelandena informerar operatören om att en speciell procedur eller en viss typ av arbete måste utföras exakt enligt anvisningarna. I annat fall finns risk för svåra personskador.



VIKTIGT!

Detta varningsmeddelande visas framför procedurer som måste följas exakt för att undvika skador på maskinen.

OBSERVERA

Detta visar på viktig information i texten.

FÖRVARING

Följande krav på omgivningsförhållanden gäller vid transport och förvaring av styrenheten:

- temperatur: från -20 °C till +70 °C
- relativ luftfuktighet: 0 - 95% (utan kondens)

FÖRBEREDELSE FÖR INSTALLATION

Styrenheten levereras i ett särskilt skyddande emballage. Kontakta det lokala försäljningskontoret om emballaget visar tecken på skador som kan ha uppstått under transporten.

Se till att styrenheten inte tappas eller utsätts för stötar vid upppackningen.

Kasta inte packmaterialet i soporna. Materialet är återvinningsbart till 100% och uppfyller EU-direktiv 85/399 om miljöskydd.

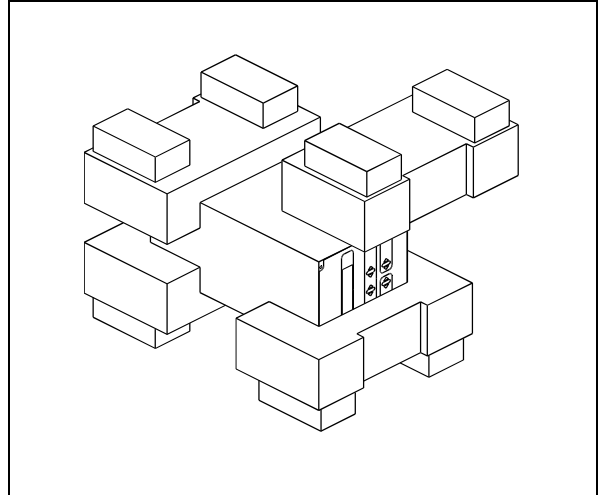

*Styrenhetens förpackning
969-9405 och 969-9505*

Styrenheten levereras från Varian med förinställning för en viss matningsspänning:

- modellen 969-9405 för 220 V växelström
- modellen 969-9505 för 120 V växelström

Om matningsspänningen behöver ändras går du tillväga på följande sätt:

- Frånkoppla strömkabeln på styrenhetens baksida.
- Kontrollera vilken spänning som är inställd på spänningsingångsmodulen.
- Ta ut spänningsingångsmodulen och tillhörande säkring med en liten skruvmejsel.
- Välj önskad matningsspänning och sätt tillbaka modulen i sitt hus.
- Kontrollera att den valda matningsspänningen är korrekt. Återanslut strömkabeln.

INSTALLATION

**WARNING!**

Styrenheten levereras med strömkabel med tre ledare och godkänd stickpropp enligt internationella standarder. Använd endast den medlevererade strömkabeln. Stickproppen får endast anslutas till ett vägguttag med fungerande jordanslutning för att undvika elstötar.

Spänningen inuti styrenheten kan nå höga värden och förorsaka allvarliga skador och dödsfall. Frånkoppla alltid strömkabeln innan något installations- eller underhållsmoment utförs på styrenheten.

OBSERVERA

Styrenheten kan installeras på ett bord eller inuti ett därtill avsett rack. I samtliga fall måste dock kylflödet kunna cirkulera fritt kring apparaten. Installera och använd inte styrenheten i miljöer som utsätts för påverkan från atmosfären (regn, snö, is), damm, aggressiva gaser, och inte heller i explosiv eller brandfarlig miljö.

Följande krav på omgivningsförhållanden gäller vid drift:

- temperatur: från 0 °C till +40 °C
- relativ luftfuktighet: 0 - 95% (utan kondens)

Pumpen och styrenheten ansluts med den speciella kabeln, som levereras med styrenheten.

NOTA

Styrenheten modell 969-9405 och 969-9505 levereras med kabel för anslutning av pumpen redan fastmonterad på styrenhetens baksida.

Beträffande övriga anslutningar och installation av tillbehör hänvisas till avsnittet "Technical Information".

ANVÄNDNING

Detta avsnitt beskriver de viktigaste driftmomenten. För en detaljerad beskrivning samt beträffande moment som involverar anslutningar eller tillbehör hänvisas till avsnittet "Use" i bilaga "Technical Information".

Innan styrenheten används bör samtliga elektriska och pneumatiska anslutningar utföras. Läs bruksanvisningen för den anslutna pumpen.

**WARNING!**

Försäkra dig att pumpen står stadigt, om den är installerad på ett bord, detta för att förebygga skador på apparaten och personer. Sätt aldrig igång pumpen, om intagsflänsen varken är kopplad till systemet eller är blockerad på plats med låsflänsen.

OBSERVERA

Stängningskontakten J1 måste lämnas ansluten med aktuell brygga om ingen extern anslutning utförs. Förvakuumpumpen och Turbo-V-pumpen kan fungera samtidigt.

Kontroller, indikatorer och kontakter på Styrenheten

Nedan beskrivs manöverpanelen för styrenheten samt anslutnings-panelegerna. För ytterligare information hänvisas till bilaga "Technical Information".

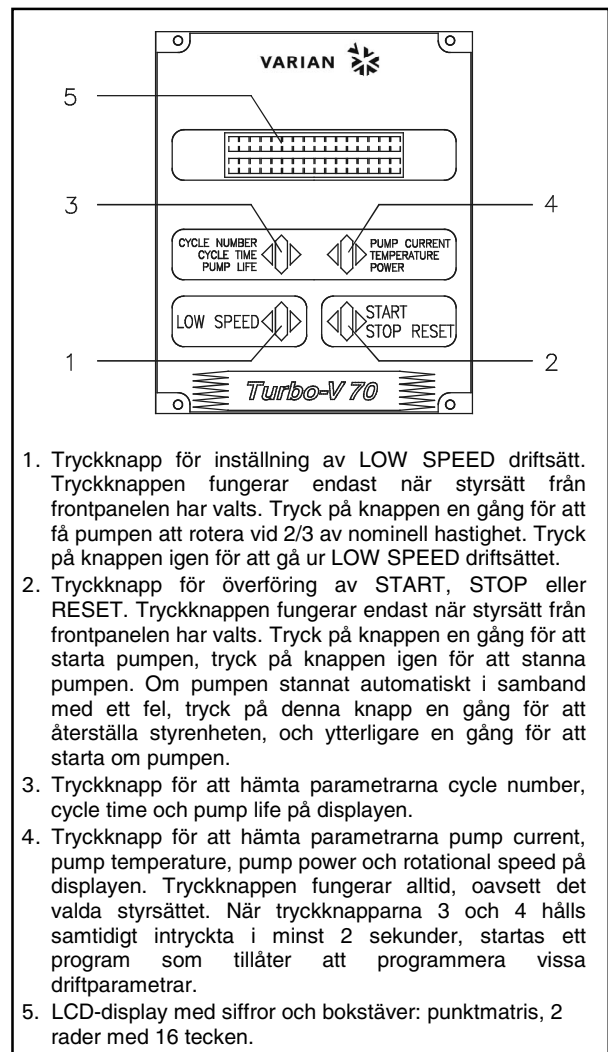

1. Tryckknapp för inställning av LOW SPEED driftsätt. Tryckknappen fungerar endast när styrsätt från frontpanelen har valts. Tryck på knappen en gång för att få pumpen att rotera vid 2/3 av nominell hastighet. Tryck på knappen igen för att gå ur LOW SPEED driftsättet.
2. Tryckknapp för överföring av START, STOP eller RESET. Tryckknappen fungerar endast när styrsätt från frontpanelen har valts. Tryck på knappen en gång för att starta pumpen, tryck på knappen igen för att stanna pumpen. Om pumpen stannat automatiskt i samband med ett fel, tryck på denna knapp en gång för att återställa styrenheten, och ytterligare en gång för att starta om pumpen.
3. Tryckknapp för att hämta parametrarna cycle number, cycle time och pump life på displayen.
4. Tryckknapp för att hämta parametrarna pump current, pump temperature, pump power och rotational speed på displayen. Tryckknappen fungerar alltid, oavsett det valda styrsättet. När tryckknapparna 3 och 4 hålls samtidigt intryckta i minst 2 sekunder, startas ett program som tillåter att programmera vissa driftparametrar.
5. LCD-display med siffror och bokstäver: punktmatris, 2 rader med 16 tecken.

Frontpanelen på Styrenheten
969-9405 och 969-9505

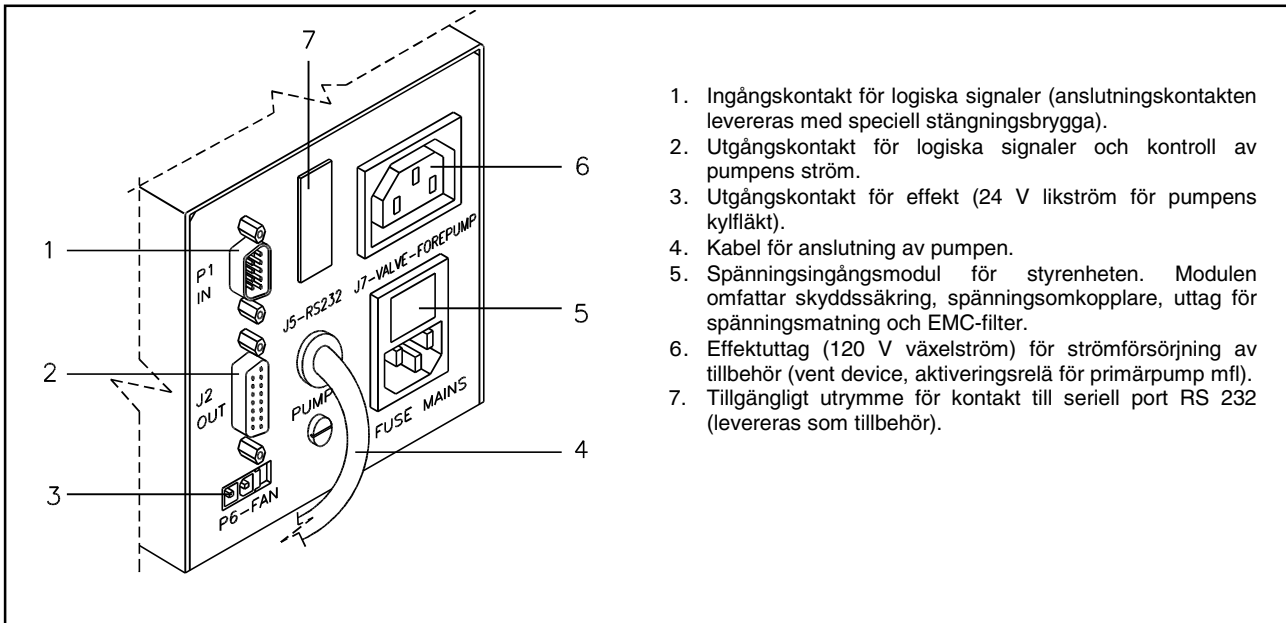

1. Ingångskontakt för logiska signaler (anslutningskontakten levereras med speciell stängningsbrygga).
2. Utgångskontakt för logiska signaler och kontroll av pumpens ström.
3. Utgångskontakt för effekt (24 V likström för pumpens kylfläkt).
4. Kabel för anslutning av pumpen.
5. Spänningsingångsmodul för styrenheten. Modulen omfattar skyddssäkring, spänningsomkopplare, uttag för spänningsmatning och EMC-filter.
6. Effektuttag (120 V växelström) för strömförsörjning av tillbehör (vent device, aktiveringsrelä för primärpump mfl).
7. Tillgängligt utrymme för kontakt till seriell port RS 232 (levereras som tillbehör).

Bakre panel på Styrenheten 969-9405 och 969-9505

INSTRUKTIONER FÖR BRUK

Start av styrenheten

Styrenheten startas enkelt genom att sätta strömkabeln i vägguttaget.

Start av pumpen

Pumpen startas genom att trycka på tryckknappen START.

Stopp av pumpen

Pumpen stoppas genom att trycka på tryckknappen STOPP på frontpanelen.

UNDERHÅLL

Styrenheterna i Turbo-V 70 serien är under-hållsfria. Allt servicearbete måste utföras av auktoriserad personal.

Om styrenheten havererar, kontakta Varian reparationsverkstad eller Varian utbytesservice, som kan ersätta styrenheten med en renoverad styrenhet.



VARNING!

Innan något arbete utförs på styrenheten måste dess strömförsörjning brytas.

Skrotning av pumpen skall ske enligt gällande lagstiftning.

FELMEDDELANDEN

När vissa fel uppstår visar styrenhetens självdiagnoskrets aktuellt felmeddelande på displayen. De möjliga meddelandena listas i följande tabell.

MEDDELANDE	BESKRIVNING	ÅTGÄRD
CHECK CONNECTION TO PUMP	Anslutningen mellan pump och styrenhet är defekt.	Kontrollera att anslutningskabeln mellan pump och styrenhet är ordentligt monterad samt att inget avbrott förekommer. Tryck två gånger på knappen START för att starta om pumpen.
PUMP WAITING INTERLOCK	Interlock-signalen finns på kontakt P1 på grund av kortslutning mellan stift 3 och stift 8 i kontakten J1, eller på grund av att den externa interlock-signalen är öppen.	Åtgärda kortslutningen mellan stift 3 och stift 8 på kontakt J1 eller stäng den externa interlock-signalen.
FAULT: OVERTIME SX	Vid uppstart av pumpen med "mjukstart" har pumpen inte nått korrekt hastighet för varje steg inom 15 minuter (X kan gälla 0 till 9 och anger vilket steg, som inte genomförts).	Kontrollera om systemet läcker. Tryck två gånger på knappen START för att starta om pumpen.
FAULT: PUMP OVERTEMP.	Temperaturen på det övre lagret eller pumpen överskrider 60 °C.	Vänta tills temperaturen sjunker under tröskelvärdet. Tryck två gånger på knappen START för att starta om pumpen.
FAULT: CONTROLLER OVERTEMPERATURE	Temperaturen på styrenhetens transformator överskrider 90 °C.	Vänta tills temperaturen sjunker under tröskelvärdet. Tryck två gånger på knappen START för att starta om pumpen.
FAULT: TOO HIGH LOAD	Under normal drift (efter startmomentet) förbrukar pumpen en större effekt än det programmerade värdet (1,5 A).	Kontrollera att pumpens rotor kan rotera fritt. Tryck två gånger på knappen START för att starta om pumpen.
FAULT: SHORT CIRCUIT	Under normal drift (efter startmomentet) har utgången kortslutits (utgångsström högre än 2,2 A).	Kontrollera anslutningarna mellan pump och styrenhet. Tryck två gånger på knappen START för att starta om pumpen.
SYSTEM OVERRIDE	Pumpen har stannats av en nödstoppsignal från en fjärrkontakt.	Frånkoppla styrenhetens strömkabel och kontrollera nödstoppets orsak. Sätt därefter i strömkabeln. Tryck två gånger på knappen START för att starta om pumpen.
OVERVOLTAGE	Ett fel i styrenhetens matningsdel har uppstått eller styrenheten har fått en falsk signal.	Tryck två gånger på knappen START för att starta om pumpen. Om meddelandet visas igen, ta kontakt med Varian för nödvändigt underhåll.
CONTROLLER FAILURE	Avbrott i säkring i den sekundära effektkretsen.	Kontakta Varian för underhåll.

GENERELL INFORMASJON

Dette utstyret er beregnet til bruk av profesjonelle brukere. Brukeren bør lese denne brukerveiledningen og all annen informasjon fra Varian før utstyret tas i bruk. Varian kan ikke holdes ansvarlig for hendelser som skjer på grunn av manglende oppfølging, selv delvis, av disse instruksjonene, feilaktig bruk av utrenet personell, ikke godkjente endringer av utstyret eller handlinger som på noen måte er i strid med nasjonale bestemmelser.

Styreenhetene i Turbo-V 70 serien er mikroprosessorstyrte frekvensomvendere, som består av komponenter med fast tilstand. Styreenhetene har funksjoner for selvdiagnose og selvbeskyttelse. Styreenhetene kontrollerer pumpene i Turbo-V 70 serien (med en titrinnspesess) ved oppstart. Spennning og strømstyrke justeres i forhold til pumpens oppnådde hastighet. Styreenhetene omfatter alle kretser som er nødvendige for automatisk drift av pumpene i Turbo-V 70 serien. En hjelpekontakt gir muligheter for fjernstyrt start og stopp av pumpen, signaler for pumpens tilstand, kontroller for start og stopp av forvakuumpumpen, blokkeringssignaler (for trykksensorer, kontrollbrytere for vannstrøm osv). De følgende avsnittene inneholder all informasjon som er nødvendig for å sikre brukeren når utstyret er i bruk. For mer detaljert bruk vises det til tillegget "Technical Information".

Denne veiledningen bruker følgende standardprotokoll:



ADVARSEL!

Disse meldingene skal tiltrekke seg brukerens oppmerksomhet til en spesiell fremgangsmåte eller praksis som, hvis den ikke følges, kan medføre alvorlige skader.



FORSIKTIG!

Denne advarselen vises foran fremgangsmåter som, dersom de ikke følges, kan føre til at utstyret skades.

MERK

Merknadene inneholder viktig informasjon som er hentet fra teksten.

LAGRING

Når styreenhetene transporteres eller lagres, må følgende forhold være oppfylt:

- temperatur: fra 20 °C til +70 °C
- relativ fuktighet: 0 - 95% (uten kondens)

FORBEREDE INSTALLASJONEN

Styreenheten leveres i en spesiell beskyttelsesemballasje. Viser denne tegn på skader som kan ha oppstått under transporten, må du ta kontakt med det lokale salgskontoret.

Når styreenheten pakkes ut, må du passe på at den ikke slippes ned eller utsettes for noen form for støt. Emballasjen må ikke kastes på en ulovlig måte. Alle materialer er 100% resirkulerbare og er i samsvar med EU-direktiv 85/399 om miljøbeskyttelse.

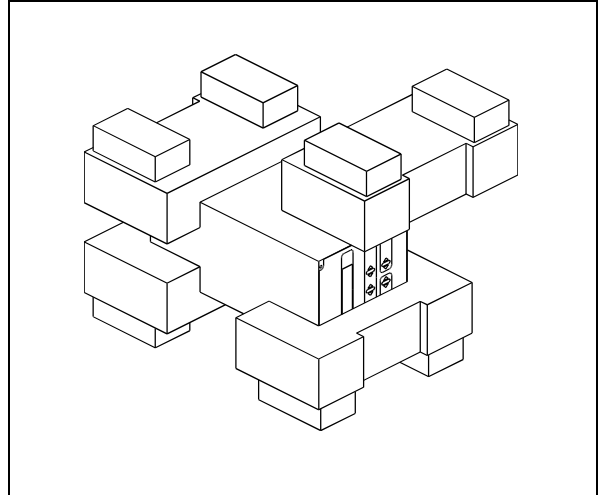

Styreenhetens emballasje
969-9405 og 969-9505

Styreenheten leveres fra Varian med forhåndsinnstillinger for en viss nettspenning:

- modellen 969-9405 for 220 V vekselstrøm
- modellen 969-9505 for 120 V vekselstrøm

Gå frem slik dersom innstilt nettspenning må endres:

- Kople fra strømkabelen på styreenhetens bakside.
- Kontroller hvilken spenning som er stilt inn på spenningsinngangsmodulen.
- Ta ut spenningsinngangsmodulen og tilhørende sikring med en liten skrutrekker.
- Velg ønsket nettspenning og sett modulen tilbake i huset.
- Kontroller at den valgte nettspenningen er korrekt, og kople maskinen til strømmettet.

INSTALLASJON



ADVARSEL!

Styreenheten leveres med strømkabel med tre ledere og godkjent støpsel i henhold til internasjonale standarder. Bruk kun den vedlagte strømkabelen. Støpslet må kun benyttes i en veggkontakt som har tilfredsstillende jording, slik at faren for strømstøt kan unngås.

Spenningen inne i styreenheten kan nå høye verdier og kan føre til alvorlige skader og dødsfall. Kople alltid strømkabelen fra strømmettet før alle installasjons- eller vedlikeholdsarbeider som utføres på styreenheten.

MERK

Styreenheten kan installeres på et bord eller inne i et passende stativ. Uansett så må kjøleluften kunne sirkulere fritt rundt apparatet. Ikke installer eller bruk styreenheten i miljøer som utsettes for regn, snø eller is, støv, aggressive gasser, eksplosjonsfarlige miljøer eller i miljøer med stor brannfare.

Under bruk må følgende forhold respekteres:

- temperatur: fra 0 °C til +35°C
- relativ fuktighet: 0 - 95% (uten kondens)

Pumpen og styreenheten tilkoples den spesielle kablen som leveres sammen med styreenheten.

MERK

Styreenheten modell 969-9405 og 969-9505 leveres med kabel for tilkopling av pumpen allerede fastmontert på styreenhetens bakside.

Når det gjelder andre tilkoplinger og installasjon av ekstrautstyr vises det til avsnittet "Technical Information".

BRUK

Dette avsnittet beskriver de viktigste driftsmomentene. For en detaljert beskrivelse samt moment som omfatter tilkoplinger eller ekstrautstyr vises det til avsnittet "Use" i vedlegget "Technical Information".

Før styreenheten tas i bruk bør samtlige elektriske og pneumatiske tilkoplinger gjøres. Les brukerveiledningen for pumpen som er tilkopledd.



ADVARSEL!

Dersom pumpen er installert på et bord må du kontrollere at pumpen står støtt. Dette er viktig for å forhindre skader på apparatet og på personer. Dersom inngangsslensen hverken er tilkopledd systemet eller dersom den er blokkert av låseflensen må pumpen aldri startes opp.

MERK

Lukkekontakten J1 må være tilkopledd aktuell brygge dersom det ikke skjer en annen ekstern tilkopling. Forvakuumpumpen og Turbo-V-pumpen må fungere sammen.

Kontroller, indikatorer og kontakter på styreenheten

Nedenfor beskrives styrepanelet til styreenheten samt tilkoplingspanelene. For ytterligere informasjon vises det til avsnittet "Accessories and Spare Parts" i vedlegget "Technical Information".

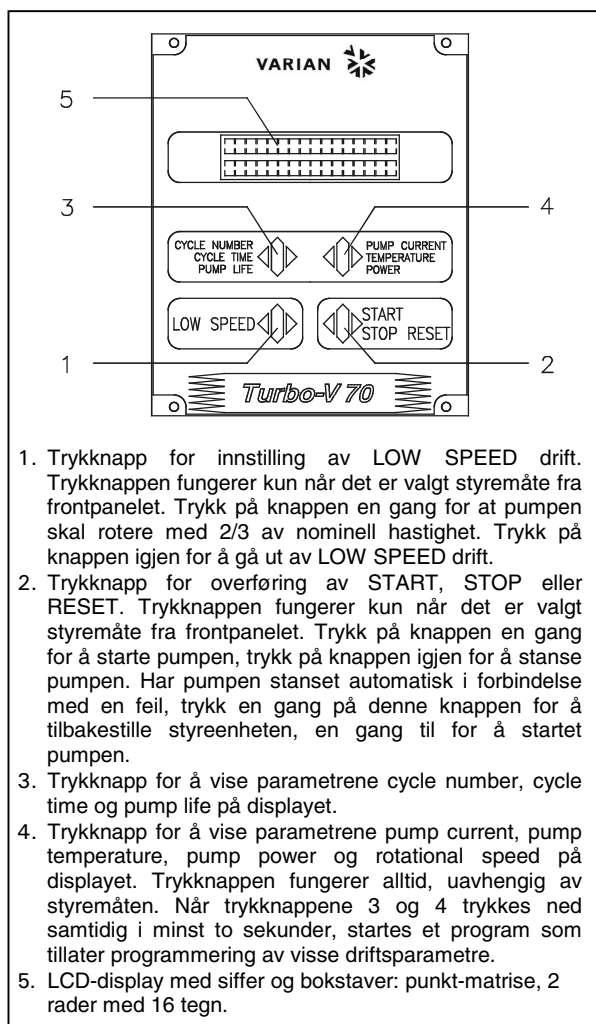

Frontpanelet på styreenheten
969-9405 og 969-9505

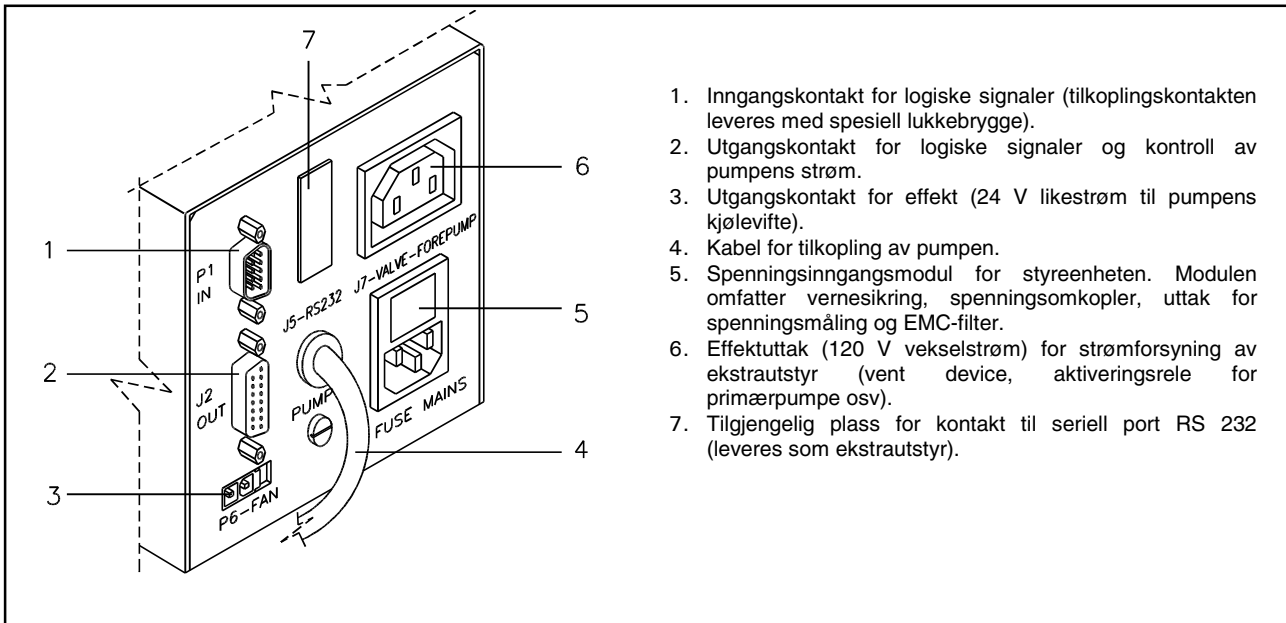

1. Inngangskontakt for logiske signaler (tilkoplingskontakten leveres med spesiell lukkebrygge).
2. Utgangskontakt for logiske signaler og kontroll av pumpens strøm.
3. Utgangskontakt for effekt (24 V likestrøm til pumpens kjølevifte).
4. Kabel for tilkopling av pumpen.
5. Spenningsinngangsmodul for styreenheten. Modulen omfatter vernesikring, spenningsomkopler, uttak for spenningsmåling og EMC-filter.
6. Effekttuttak (120 V vekselstrøm) for strømforsyning av ekstrautstyr (vent device, aktiveringsrele for primærpumpe osv).
7. Tilgjengelig plass for kontakt til seriell port RS 232 (leveres som ekstrautstyr).

Bakpanelet på styreenheten 969-9405 og 969-9505

INSTRUKSJONER FOR BRUK

Starte styreenheten

Styreenheten startes ved å sette strømkabelen i veggkontakten.

Starte pumpen

Pumpen startes ved å trykke på knappen START.

Stoppe pumpen

Pumpen stoppes ved å trykke på knappen STOPP på frontpanelet.

VEDLIKEHOLD

Turbo-V 70 seriens styreenheter er vedlikeholdsfrie. Alt arbeid på styreenheten må kun utføres av autorisert personell.

Dersom styreenheten stanser, må du ta kontakt med Varians reparasjonsservice eller med Varians avanserte bytteservice, som kan tilby overhalte styreenheter til erstatning for den ødelagte styreenheten.

**ADVARSEL!**

Før noe arbeid utføres på styreenheten, må den frakoples strømmettet.

Dersom en styreenhet skal kasseres, må dette skje i henhold til nasjonale bestemmelser.

FEILMELDINGER

Når det oppstår visse feil viser selvdiagnosekretsen i styreenheten den aktuelle feilmeldingen i displayet. De aktuelle feilmeldingen fremgår av tabellen nedenfor.

MELDING	BESKRIVELSE	FORHOLDSREGEL
CHECK CONNECTION TO PUMP	Defekt kopling mellom pumpe og styreenhet.	Kontroller at tilkoplingskabelen mellom pumpe og styreenhet er skikkelig montert samt at kabelen ikke er skadet. Trykk to ganger på knappen START for å starte pumpen.
PUMP WAITING INTERLOCK	Låsesignalet for kontakt P1 skyldes en kortslutning mellom stift 3 og stift 8 i kontakten J1 eller fordi det eksterne låsesignalet er åpent.	Tilbakestill kortslutningen mellom stift 3 og stift 8 på kontakt J1 eller steng det eksterne låsesignalet.
FAULT: OVERTIME SX	Ved oppstart av pumpen med "mykstart" har pumpen ikke nådd den korrekte hastigheten for hvert trinn i løpet av 15 minutter (X kan gjelde 0 til 9 og angir hvilket trinn som ikke har blitt gjennomført).	Kontroller om systemet lekker. Trykk to ganger på knappen START for å starte pumpen.
FAULT: PUMP OVERTEMP.	Temperaturen på det øvre lageret eller pumpen er over 60 °C.	Vent til temperaturen synker under terskelverdien. Trykk to ganger på knappen START for å starte pumpen.
FAULT: CONTROLLER OVERTEMPERATURE	Temperaturen på styreenhetens transformator er over 90 °C.	Vent til temperaturen synker under terskelverdien. Trykk to ganger på knappen START for å starte pumpen.
FAULT: TOO HIGH LOAD	Ved normal drift (etter startmomentet) bruker pumpen mer effekt enn den programmerte verdienn (1,5 A).	Kontroller om pumpens rotor kan rotere fritt. Trykk to ganger på knappen START for å starte pumpen.
FAULT: SHORT CIRCUIT	Ved normal drift (etter startmomentet) er utgangen kortsluttet (utgangsstrøm over 2,2 A).	Kontroller tilkoplingene mellom pumpe og styreenhet. Trykk to ganger på knappen START for å starte pumpen.
SYSTEM OVERRIDE	Pumpen har stanset av et nødstoppsignal en fra fjernkontakt.	Kople fra styreenhetens strømkabel og finn frem til årsaken til nødstoppen. Kople deretter maskinen til strømmettet igjen. Trykk to ganger på knappen START for å starte pumpen.
OVERVOLTAGE	Det har oppstått en feil i styreenhetens matedel, eller så har styreenheten fått et falskt signal.	Trykk to ganger på knappen START for å starte pumpen igjen. Viser feilmeldingen om igjen, må du ta kontakt med Varian for nødvendig vedlikehold.
CONTROLLER FAILURE	Avbrudd i sikringen til det sekundæra effektkretslopet.	Kontakt Varian for vedlikehold.

YLEISIÄ TIETOJA

Tämä laite on tarkoitettu ammattimaiseen käyttöön. Ennen laitteen käyttöönottoa käyttäjän tulee lukea huolellisesti mukana seuraava käyttöohje sekä kaikki muut Varianin toimittamat lisätiedot. Varian ei vastaa seurauksista, jotka johtuvat laitteen käyttöohjeiden täydellisestä tai osittaisesta laiminlyömisestä, ammattitaidottomien henkilöiden suorittamasta laitteen virheellisestä käytöstä, valtuuttamattomista toimenpiteistä tai maakohtaisten säädösten ja normien vastaisesta käytöstä.

Sarjan Turbo-V 70 valvojat ovat mikroprosessorien valvomia kiinteistä materiaaleista tehtyjä taajuudenmuuntimia, jotka kykenevät itsemäärätelyyn ja itsesuojaukseen. Valvojat ajavat Turbo-V 70 sarjan pumppuja (kymmenportaisessa järjestelmässä) käynnistysvaiheessa valvoen jännitettä ja sähkövirtaa suhteessa pumpun saavuttamaan nopeuteen. Ne yhdistävät kaikki sähköpiirit, jotka ovat välttämättömiä Turbo-V 70 sarjan pumpun automaattiselle toiminnalle. Apuliittimiä käyttäen on mahdollista käyttää kauko-ohjattua pumpun käynnistystä ja pysähdystä, signaaleja, jotka ilmaisevat pumpun toimintatilan, esityhjennyspumpun käynnistys- ja pysähdyssäätimiä, veden virtauksen säätelykatkaisijaa jne. Seuraavilla sivuilla on luettavissa tarpeelliset tiedot laitteen käyttäjän turvallisuuden takaamiseksi laitteen käytön aikana. Yksityiskohtaiset tiedot löytyvät liitteestä "Tekniset tiedot".

Tämä käsikirja käyttää seuraavia merkintöjä:



VAARA!

Vaara-merkinnät saavat käyttäjän huomion kiinnittymään erityisiin toimintotapoihin, joiden seuraamatta jättäminen voi aiheuttaa vakavia henkilövaurioita.



HUOMIO!

Huomio-merkinnät varoittavat toiminnoista, joiden laiminlyönti voi johtaa laitteen vaurioitumiseen.

HUOM

Huomiot sisältävät tärkeätä tekstistä otettua tietoa.

VARASTOINTI

Valvojan kuljetuksen ja varastoinnin aikana tulevat seuraavat ympäristövaatimukset olla täytettyinä:

- lämpötila: -20 °C ja +70 °C asteen välillä
- suhteellinen kosteus: 0 - 95% (ilman lauhdetta)

VALMISTELUT ASENNUSTA VARTEN

Valvoja toimitetaan erityisessä suojaavassa pakkauksessa. Mikäli havaitsette mahdollisesti kuljetuksen aikana sattuneita vaurioita, ottakaa yhteys paikalliseen myyntitoimistoon.

Pakkauksen purkamisen yhteydessä huolehtikaa, että valvoja eipääse putoamaan ja välttää sen joutumista iskujen kohteeksi.

Älkää jättäkö pakkausta ympäristöön. Materiaali voidaan kokonaisuudessaan kierrättää ja se vastaa EY:n 85/399 direktiiviä ympäristön suojelusta.

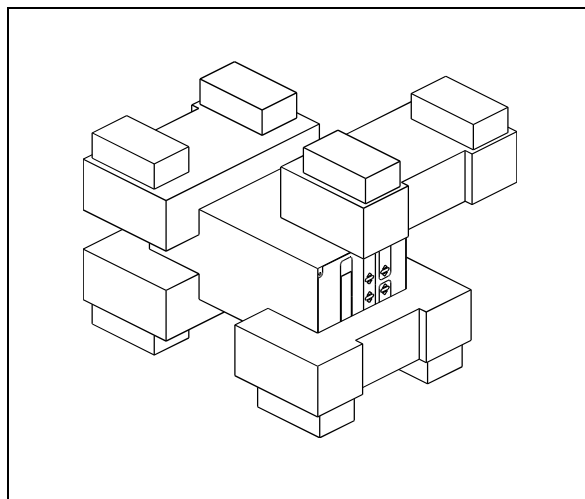

*Valvojan pakkaus
969-9405 ja 969-9505*

Jokainen valvoja on tehtaalla säädetty tietyille sähköjännitteelle:

- malli 969-9405 säädetty 220 vaihtovirta
- malli 969-9505 säädetty 120 vaihtovirta

Mikäli sähköjännite joudutaan vaihtamaan, seurakaa seuraavia toimintaohjeita:

- Irroittakaa virtakaapeli valvojan takaosassa olevasta panelista.
- Tarkistakaa jännitteen syöttömoduulista säädetty jännite.
- Vetäkää ulos jännitteen valintamoduuli sulakkeineen pientä ruuvimeisseliä käyttäen.
- Valitkaa haluttu sähköjännite, jonka jälkeen asettakaa moduuli uudelleen huolellisesti sille tarkoitettuun tilaan.
- Tarkistakaa, että valittu jännite on oikea ja kytkekää virtakaapeli uudelleen.

ASENNUS

**VAARA!**

Valvoja toimitetaan kolmijohtoisella sähkökaapelilla, jonka pistoke on kansainvälisesti hyväksytty. Käyttäkää aina tätä kaapelia ja asettakaa pistoke riittävästi maadoitettuun pistorasiaan, jotta sähköiskulta vältytään.

Valvojan sisällä syntyy korkeajännitettä, joka voi aiheuttaa vakavia vammoja tai jopa kuoleman. Ennen minkätähansa valvojan huolto-tai asennustoimenpiteen suorittamista, irroittakaa valvoja sähköverkosta.

HUOM

Valvoja voidaan asentaa pöydän päälle tai siihen tarkoitukseen sopivan hyllyn sisään. Joka tapauksessa huolehtikaa siitä, että riittävä jäähdytysilma pääsee vapaasti kiertämään laitteen sisällä. Älkää asentako ja/tai käyttäkö valvojaa tiloissa, joissa se joutuu alttiiksi ympäristötekijöille (sade, jää, lumi), pölylle, syövyttävälle kaasulle, räjähdysalttiissa ympäristössä tai tiloissa, joissa paloriski on suuri.

Toiminnan aikana tulee noudattaa seuraavia ympäristönoloja koskevia sääntöjä:

- lämpötila: 0 °C ja +40 °C välillä
- suhteellinen kosteus: 0 - 95% välillä (ilman lauhdetta)

Valvojaa kytkettäessä sille tarkoitettuun pumppuun käyttäkää valvojalle tarkoitettua erityiskaapelia.

HUOM

Valvojamalleissa 969-9405 ja 969-9505 on pumpun liitiskaapeli kiinnitettynä itse valvojan takaosan paneeliin.

Muiden kytkentöjen ja valinnaisten lisälaitteiden asennusten suorittamiseksi, katsokaa kappaletta "Tekniset tiedot".

KÄYTTÖ

Tähän kappaleeseen on kirjattu tärkeimmät käyttötoimenpiteet. Tarkempia lisätietoja sekä kytkentöjä, että valinnaisia lisälaitteita koskevien toimenpiteiden suorittamista käsittäviä tietoja löydätte kappaleesta "Käyttö", joka on "Tekniset tiedot"-kappaleen liitteenä.

Ennen valvojan käyttöä suorittaakaa kaikki sähkökytkennät seuraten kytkettävän pumpun käyttöohjeita.

**VAARA!**

Mikäli pumppu on asetettu pöydälle, varmistakaa että se on vakaa. Näin vältytään vammoilta ihmisille sekä itse koneelle. Älkää myöskään käyttäkö pumppua, mikäli sisääntulon laippaa ei ole kytketty järjestelmään tai mikäli sitä ei ole suljettu laippasulkijalla.

HUOM

Sulkimen J1 liitin tulee jättää yhdyskaapelilla kytkettynä, mikäli ulkoisia kytkentöjä ei suoriteta. Esityhjennyspumppu ja Turbo-V pumppu voidaan käynnistää samanaikaisesti.

Valvojan säätimet, osoittimet ja liittimet

Seuraavassa on esitelty Valvojan valvontapaneli ja yhteyspaneli. Tarkempia lisätietoja saatte kappaleesta "Tekniset Tiedot".

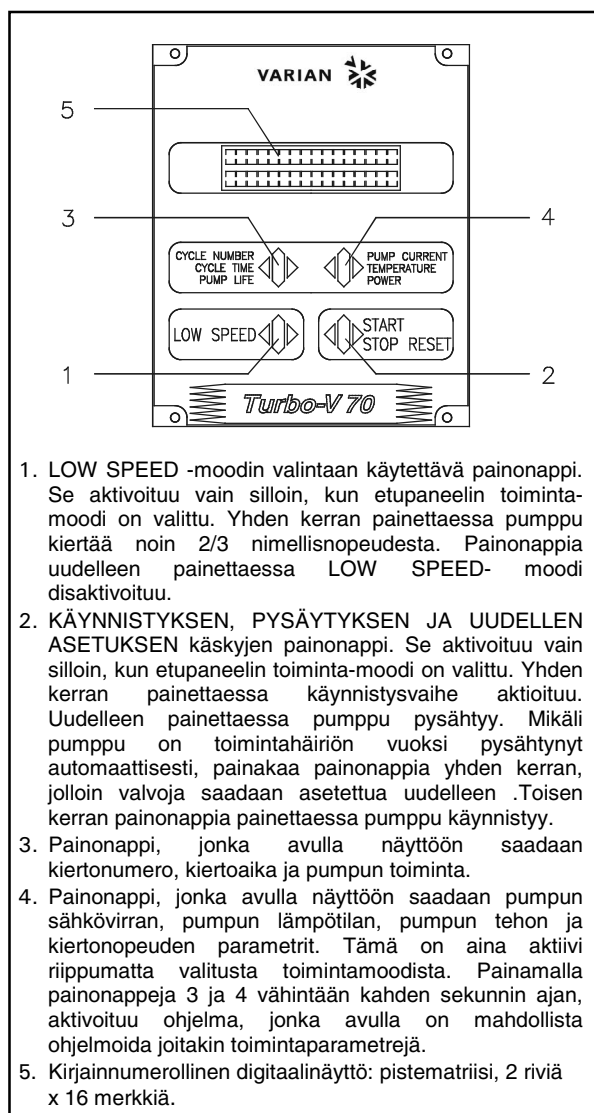

1. LOW SPEED -moodin valintaan käytettävä painonappi. Se aktivoituu vain silloin, kun etupaneelin toimintamoodi on valittu. Yhden kerran painettaessa pumppu kiertää noin 2/3 nimellisuopeudesta. Painonappia uudelleen painettaessa LOW SPEED- moodi disaktivoituu.
2. KÄYNNISTYKSEN, PYSÄYTYKSEN JA UUELLEN ASETUKSEN käskyjen painonappi. Se aktivoituu vain silloin, kun etupaneelin toimintamoodi on valittu. Yhden kerran painettaessa käynnistysvaihe aktioituu. Uudelleen painettaessa pumppu pysähtyy. Mikäli pumppu on toimintahäiriön vuoksi pysähtynyt automaattisesti, painakaa painonappia yhden kerran, jolloin valvoja saadaan asetettua uudelleen. Toisen kerran painonappia painettaessa pumppu käynnistyy.
3. Painonappi, jonka avulla näyttöön saadaan kiertonumero, kiertoaika ja pumpun toiminta.
4. Painonappi, jonka avulla näyttöön saadaan pumpun sähkövirran, pumpun lämpötilan, pumpun tehon ja kiertonopeuden parametrit. Tämä on aina aktiivi riippumatta valitusta toimintamoodista. Painamalla painonappeja 3 ja 4 vähintään kahden sekunnin ajan, aktivoituu ohjelma, jonka avulla on mahdollista ohjelmoida joitakin toimintaparametrejä.
5. Kirjainnumerosellinen digitaalinen näyttö: pistematriisi, 2 riviä x 16 merkkiä.

Valvojen 969-9405 ja 969-9505 etupanelit

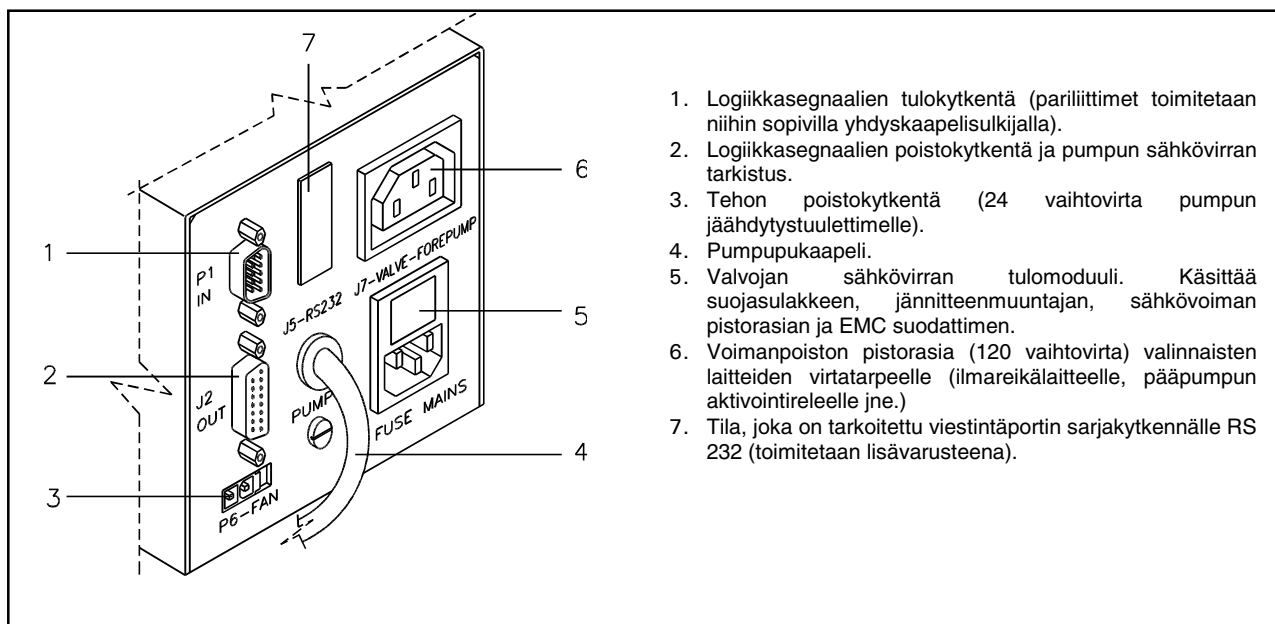

1. Logiikkasegnaalien tulokytettä (pariliittimet toimitetaan niihin sopivilla yhdyskaapelisulkijalla).
2. Logiikkasegnaalien poistokytettä ja pumpun sähkövirran tarkistus.
3. Tehon poistokytettä (24 vaihtovirta pumpun jäädytystuulettimelle).
4. Pumpupukaapeli.
5. Valvojan sähkövirran tulomoduuli. Käsittää suojasulakkeen, jännitteenmuuntajan, sähkövoiman pistorasian ja EMC suodattimen.
6. Voimanpoiston pistorasia (120 vaihtovirta) valinnaisten laitteiden virtatarpeelle (ilmareikälaitteelle, pääpumpun aktivointireleelle jne.)
7. Tila, joka on tarkoitettu viestintäportin sarjakytännälle RS 232 (toimitetaan lisävarusteena).

Valvojen 969-9405 ja 969-9505 takapaneli

KÄYTTÖTOIMENPITEET

Valvojan päälle pano

Valvoja käynnistyy asettamalla virtakaapeli pistorasiaan.

Pumpun käynnistys

Pumppu käynnistyy painamalla START painonappia.

Pumpun pysäyttäminen

Pumppu pysähtyy painamalla etupanelissa olevaa STOP painonappia.

HUOLTO

Turbo-V 70 sarjan valvojat eivät kaipaakaan minkäänlaista huoltoa. Mahdolliset valvojaan tehtävät toimenpiteet tulee jättää aina valtuutetun henkilön tehtäviksi.

Toimintahäiriön sattuessa on mahdollista käyttää Varianin korjauspalvelua tai "Varian advance exchange service" -palvelua, jolloin on mahdollista vaihtaa rikkoontunut valvoja ladattuun valvojaan.



VAARA!

Ennen minkätahansa valvojaan tehtävän toimenpiteen suorittamista irroitakaa sähkökaapeli pistorasiasta.

Mikäli valvoja täytyy romuttaa, toimikaa sen hävittämisessä kansallisten säädösten ja normien määrävällä tavalla.

VIANETSINTÄ

Joidenkin toimintahäiriöiden yhteydessä valvojan itsemäärätelypiiri analysoi virheen, joka näkyy viesteinä, jotka on kuvailtu seuraavassa taulukossa.

VIESTI	VIKA	KORJAUSTOIMENPITEET
CHECK CONNECTION TO PUMP	Toimintahäiriö pumpun ja valvojan liittännässä.	Tarkistakaa että pumpun ja valvojan välinen yhteyskaapeli on hyvin kiinnitetty päistään eikä sen varrella ole esteitä. Painakaa kaksi kertaa painonappia START jolloin pumppu käynnistyy.
PUMP WAITING INTERLOCK	Lukitusignaali (interlock) liittimessä P1 on aktiivinen johtuen liittimen J1 neulojen 3 ja 8 välillä tapahtuneen oikosulun keskeytyksestä tai ulkoisen lukitusignaalin (interlock) avautumisesta.	Palauttakaa liittimen J1 neulojen 3 ja 8 välinen oikosulku tai sulkekaa ulkopuolinen lukitusignaali (interlock).
FAULT: OVERTIME SX	"Soft Start" moodissa tapahtuvan pumpun käynnistyksen aikana pumppu ei ole saavuttanut sille joka askeleella tarkoitettua nopeutta 15 minuutin sisällä. (X on askelnumero 09 ja ilmaisee sen askeleen, jota ei ole ylitetty).	Tarkistakaa, ettäjärjestelmässä ei ole vuotoja. Painakaa painonappia START kaksi kertaa, jolloin pumppu käynnistyy.
FAULT: PUMP OVERTEMP.	Ylemmän laakerin tai pumpun lämpötila on ylittänyt 60 °C.	Odottakaa että lämpötila putoaa kynnysarvon alapuolelle. Painakaa painonappia START kaksi kertaa jolloin pumppu käynnistyy.
FAULT: CONTROLLER OVERTEMPERATURE	Valvojan muuntajan lämpötila on ylittänyt 90 °C.	Odottakaa, että lämpötila putoaa kynnysarvon alapuolelle. Painakaa painonappia START kaksi kertaa jolloin pumppu käynnistyy.
FAULT: TOO HIGH LOAD	Normaalityöskentelyn aikana (käynnistyksen jälkeen) pumpun absorboima sähkövirta on korkeampi kuin sille on ohjelmoitu (1,5 A).	Tarkistakaa, että pumpun roottori pyörii vapaasti. Painakaa painonappia START kaksi kertaa jolloin pumppu käynnistyy.
FAULT: SHORT CIRCUIT	Normaalityöskentelyn aikana (käynnistyksen jälkeen) poistoliitin on oikosulussa (poistuva virta suurempi kuin 2,2 A).	Tarkistakaa pumpun ja valvojan välinen liitos. Painakaa painonappia START kaksi kertaa jolloin pumppu käynnistyy.
SYSTEM OVERRIDE	Kaukokytkimestä tuleva hälytyssignaali on pysäyttänyt pumpun.	Irroitakaa valvojan sähkökaapeli verkkovirrasta ja korjatkaa hälytyksen aiheuttaja. Kytkekää sähkökaapeli uudelleen ja painakaa painonappia START kaksi kertaa jolloin pumppu käynnistyy.
OVERVOLTAGE	Valvojan sähkövirran syötössä on ilmennyt ongelma tai valvojan sama signaali on väärä.	Painakaa painonappia START kaksi kertaa, jolloin pumppu käynnistyy. Mikäli viesti näkyy uudelleen kääntykää Varian huoltopalvelun puoleen.
CONTROLLER FAILURE	Sulake palanut toisiovirtapiirissä.	Ota yhteys Varianiin huoltoa varten.

ΓΕΝΙΚΕΣ ΠΛΗΡΟΦΟΡΙΕΣ

Αυτή η συσκευή προορίζεται για επαγγελματική χρήση. Ο χρήστης θα πρέπει να διαβάσει προσεκτικά τις οδηγίες του παρόντος εγχειριδίου και οποιαδήποτε άλλη πρόσθετη πληροφορία που παρέχεται από τη Varian, πριν από τη χρησιμοποίηση της συσκευής. Η Varian δεν φέρει καμία ευθύνη όσον αφορά την ολική ή μερική αθέτηση των οδηγιών, την ακατάλληλη χρήση εκ μέρους ανεκπαίδευτου προσωπικού, αυθαίρετες επεμβάσεις ή χρήση που δεν συμφωνεί με τις ειδικές εθνικές διατάξεις. Ο ρυθμιστής της σειράς Turbo-V 70 είναι ένας μετατροπέας συχνότητας, ελεγχόμενος από έναν μικροεπεξεργαστή, πραγματοποιημένος από εξαρτήματα σε στερεά κατάσταση και έχει αυτοδιαγνωστική και αυτοπροστατευτική ικανότητα.

Ο ρυθμιστής οδηγεί τις αντλίες της σειράς Turbo-V 70 (με μια διαδικασία που διαιρείται σε δέκα στάδια) κατά τη διάρκεια εκκίνησης ελέγχοντας την τάση και το ηλεκτρικό ρεύμα σε σχέση με την ταχύτητα στην οποία θα φτάσει η αντλία. Αυτός εσωματώνει όλα τα ανγκαία κυκλώματα για την αυτόματη λειτουργία των αντλιών της σειράς Turbo-V 70.

Με τη βοήθεια ενός βοηθητικού βύσματος είναι διαθέσιμοι όλοι οι χειρισμοί για την εκκίνηση και το σταμάτημα της αντλίας εξ αποστάσεως, τα σήματα που δείχνουν την κατάσταση λειτουργίας της αντλίας, οι χειρισμοί εκκίνησης και σταματήματος της αντλίας προκενου, τα σήματα μπλοκαρίσματος (για διακόπτες πίεσης, διακόπτες ελέγχου της ροής του νερού, κλπ.).

Στις επόμενες παραγράφους αναφέρονται όλες οι απαραίτητες πληροφορίες που εγγυούνται την ασφάλεια του χειριστή κατά τη διάρκεια της χρησιμοποίησης της συσκευής. Λεπτομερείς πληροφορίες παρέχονται στο παράρτημα "Technical Information".

Αυτό τό εγχειρίδιο χρησιμοποιεί τις ακόλουθες συμβάσεις:



ΚΙΝΔΥΝΟΣ

Οι ενδείξεις κινδύνου προσελκύουν την προσοχή του χειριστή σε μια διαδικασία ή σε μια ειδική εργασία η οποία εάν δεν εκτελεστεί σωστά, θα μπορούσε να προκαλέσει σοβαρές προσωπικές βλάβες.



ΠΡΟΣΟΧΗ

Οι ενδείξεις προσοχής εμφανίζονται πριν από τις διαδικασίες οι οποίες εάν δεν εκτελεστούν με προσοχή, θα μπορούσαν να προκαλέσουν ζημιές στη συσκευή.

ΣΗΜΕΙΩΣΗ

Οι σημειώσεις περιέχουν σημαντικές πληροφορίες που έχουν αποσπαστεί από το κείμενο.

ΑΠΟΘΗΚΕΥΣΗ

Κατά τη διάρκεια της μεταφοράς και της αποθήκευσης των ρυθμιστών πρέπει να τηρούνται οι ακόλουθες περιβαλλοντικές συνθήκες:

- θερμοκρασία: -20 °C έως +70 °C
- σχετική υγρασία: 0 - 95% (ασυμπύκνωτη)

ΠΡΟΕΤΟΙΜΑΣΙΑ ΓΙΑ ΤΗΝ ΕΓΚΑΤΑΣΤΑΣΗ

Ο ρυθμιστής προμηθεύεται σε μία ειδική προστατευτική συσκευασία. Αν υπάρχουν ενδείξεις βλάβης που θα μπορούσαν να έχουν προκληθεί κατά τη διάρκεια της μεταφοράς, έρχεστε σε επαφή με το τοπικό τμήμα πωλήσεων.

Κατά τη διάρκεια του ανοίγματος της συσκευασίας, δώστε ιδιαίτερη προσοχή έτσι ώστε να μην πέσει και να μην χτυπηθεί ο ρυθμιστής.

Μην εγκαταλείπετε τη συσκευασία στο περιβάλλον. Το υλικό ανακυκλώνεται πλήρως και ανταποκρίνεται στην Οδηγία της Ε.Ε. 85/399 για την διαφύλαξη του περιβάλλοντος.

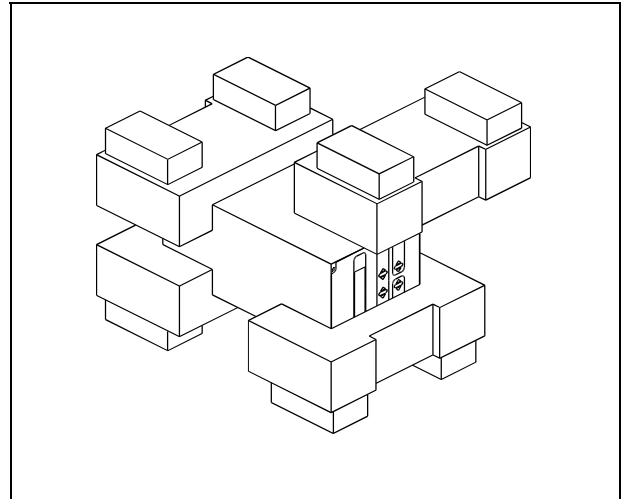

Συσκευασία των ρυθμιστών
969-9405 και 969-9505

Κάθε ρυθμιστής βγαίνοντας από την Varian έχει μία συγκεκριμένη τάση τροφοδοσίας:

- το μοντέλο 969-9405 για 220 Vac
- το μοντέλο 969-9505 για 120 Vac

Σε περίπτωση που χρειάζεται αλλαγή της τάσης ακολουθήστε την παρακάτω διαδικασία:

- Αποσυνδέστε το καλώδιο τροφοδοσίας στον πίσω πίνακα του ρυθμιστή.
- Εξακριβώστε στην ενότητα εισόδου τάσης την προδιατετημένη τάση τροφοδοσίας.
- Με ένα μικρό κατσαβίδι βγάλτε την ενότητα επιλογής τάσης με την ασφάλεια.
- Επιλέξτε την επιθυμητή τάση τροφοδοσίας και τοποθετήστε ξανά την ενότητα στην θέση της.
- Ελέγξτε αν επιλέχθηκε η σωστή τάση και συνδέστε το καλώδιο τροφοδοσίας.

ΕΓΚΑΤΑΣΤΑΣΗ



ΚΙΝΔΥΝΟΣ

Ο ρυθμιστής είναι εφοδιασμένος με τριπολικό καλώδιο τροφοδοσίας με μία πρίζα που έχει εγκριθεί διεθνώς. Να χρησιμοποιείτε πάντα αυτό το καλώδιο τροφοδοσίας και να το βάζετε σε πρίζα που να διαθέτει την κατάλληλη γείωση έτσι ώστε να αποφεύγονται ηλεκτρικές εκκενώσεις. Στο εσωτερικό του ρυθμιστή αναπτύσσονται υψηλές τάσεις που μπορούν να προκαλέσουν σοβαρούς τραυματισμούς ή και το θάνατο. Πριν εκτελέσετε οποιαδήποτε εργασία εγκατάστασης ή συντήρησης του ρυθμιστή αποσυνδέστε τον από την πρίζα τροφοδοσίας.

ΣΗΜΕΙΩΣΗ

Ο ρυθμιστής μπορεί να τοποθετηθεί επάνω σε να τραπέζι ή στο εσωτερικό μιας κατάλληλης θήκης. Σε οποιαδήποτε περίπτωση είναι αναγκαίο ο αέρας να κυκλοφορεί ελεύθερα γύρω από το σύστημα. Μην τοποθετείτε και - ή χρησιμοποιείτε τον ρυθμιστή σε χώρους εκτεθειμένους στις καιρικές συνθήκες (βροχή, πάγος, χιόνι), σκόνης, πολεμικά αέρια, σε χώρους όπου υπάρχει κίνδυνος έκρηξης ή πυρκαγιάς.

Κατά τη διάρκεια της λειτουργίας πρέπει απαραίτητως να τηρούνται οι ακόλουθες περιβαλλοντικές συνθήκες:

- θερμοκρασία: 0 °C έως + 40 °C
- σχετική υγρασία: 0 - 95% (ασυμπύκνωτη).

Για τη σύνδεση του ρυθμιστή με τη σχετική αντλία χρησιμοποιήστε το ειδικό καλώδιο του ίδιου του ρυθμιστή.

ΣΗΜΕΙΩΣΗ

Στο ρυθμιστή μοντέλο 969-9405 και 969-9505 το καλώδιο σύνδεσης με την αντλία είναι σταθεροποιημένο στον πίσω πίνακα του ίδιου του ρυθμιστή.

Για τις άλλες συνδέσεις και για την εγκατάσταση των επιπλέον εξαρτημάτων, βλέπε το παράρτημα "Technical Information".

ΧΡΗΣΗ

Σ αυτήν την παράγραφο αναφέρονται οι κυριότερες διαδικασίες λειτουργίας. Για περισσότερες λεπτομέρειες και για διαδικασίες που απαιτούν ιδιαίτερες συνδέσεις ή αξεσουάρ, αναφερθείτε στην παράγραφο "Χρήση" του Παραρτήματος "Technical Information".

Πριν χρησιμοποιήσετε τον ρυθμιστή κάντε όλες τις ηλεκτρικές και πνευματικές συνδέσεις και αναφερθείτε στο εγχειρίδιο της συνδεδεμένης αντλίας.



ΚΙΝΔΥΝΟΣ

Για να αποφύγετε βλάβες σε άτομα ή στη συσκευή, σε περίπτωση που η αντλία είναι τοποθετημένη σε ένα τραπέζι σιγουρευτείτε ότι είναι καλά σταθεροποιημένη. Μην θέτετε σε λειτουργία την αντλία αν η φλάντζα εισόδου δεν είναι συνδεδεμένη στο σύστημα ή αν δεν είναι κλειστή με την φλάντζα κλεισίματος.

ΣΗΜΕΙΩΣΗ

Το βύσμα κλεισίματος J1 θα πρέπει να αφηθεί συνδεδεμένο με τη γέφυρά του αν δεν πραγματοποιείται καμία εξωτερική σύνδεση. Η αντλία προκεινού και η αντλία Turbo-V μπορούν να ενεργοποιηθούν προσωρινά.

Χειριστήρια, δείκτες και βύσματα του Ρυθμιστή

Στη συνέχεια παρουσιάζονται οι πίνακες ελέγχου του Ρυθμιστή και οι πίνακες διασύνδεσης.

Για περισσότερες λεπτομέρειες αναφερθείτε στο παράρτημα "Technical Information".

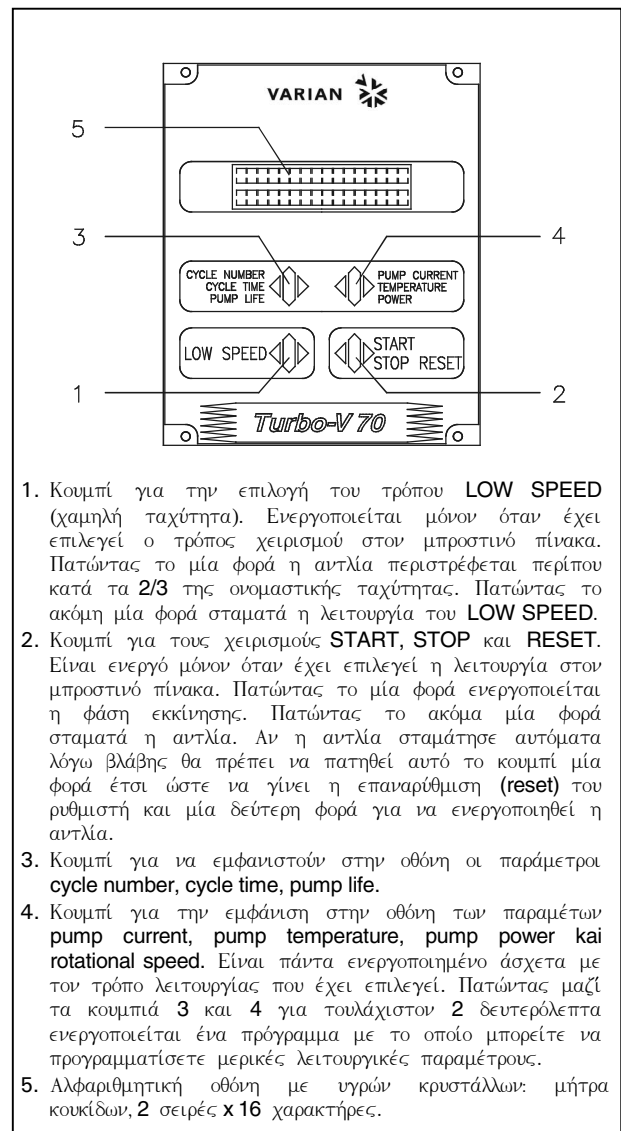

1. Κουμπί για την επιλογή του τρόπου **LOW SPEED** (χαμηλή ταχύτητα). Ενεργοποιείται μόνον όταν έχει επιλεγεί ο τρόπος χειρισμού στον μπροστινό πίνακα. Πατώντας το μία φορά η αντλία περιστρέφεται περίπου κατά τα 2/3 της ονομαστικής ταχύτητας. Πατώντας το ακόμη μία φορά σταματά η λειτουργία του **LOW SPEED**.
2. Κουμπί για τους χειρισμούς **START, STOP** και **RESET**. Είναι ενεργό μόνον όταν έχει επιλεγεί η λειτουργία στον μπροστινό πίνακα. Πατώντας το μία φορά ενεργοποιείται η φάση εκκίνησης. Πατώντας το ακόμα μία φορά σταματά η αντλία. Αν η αντλία σταμάτησε αυτόματα λόγω βλάβης θα πρέπει να πατηθεί αυτό το κουμπί μία φορά έτσι ώστε να γίνει η επαναρύθμιση (**reset**) του ρυθμιστή και μία δεύτερη φορά για να ενεργοποιηθεί η αντλία.
3. Κουμπί για να εμφανιστούν στην οθόνη οι παράμετροι **cycle number, cycle time, pump life**.
4. Κουμπί για την εμφάνιση στην οθόνη των παραμέτρων **pump current, pump temperature, pump power** και **rotational speed**. Είναι πάντα ενεργοποιημένο άσχετα με τον τρόπο λειτουργίας που έχει επιλεγεί. Πατώντας μαζί τα κουμπιά 3 και 4 για τουλάχιστον 2 δευτερόλεπτα ενεργοποιείται ένα πρόγραμμα με το οποίο μπορείτε να προγραμματίσετε μερικές λειτουργικές παραμέτρους.
5. Αλφαριθμητική οθόνη με υγρών κρυστάλλων: μήτρα κοκίδων, 2 σειρές x 16 χαρακτήρες.

Εμπρόσθιος πίνακας του Ρυθμιστή 969-9405 και 969-9505

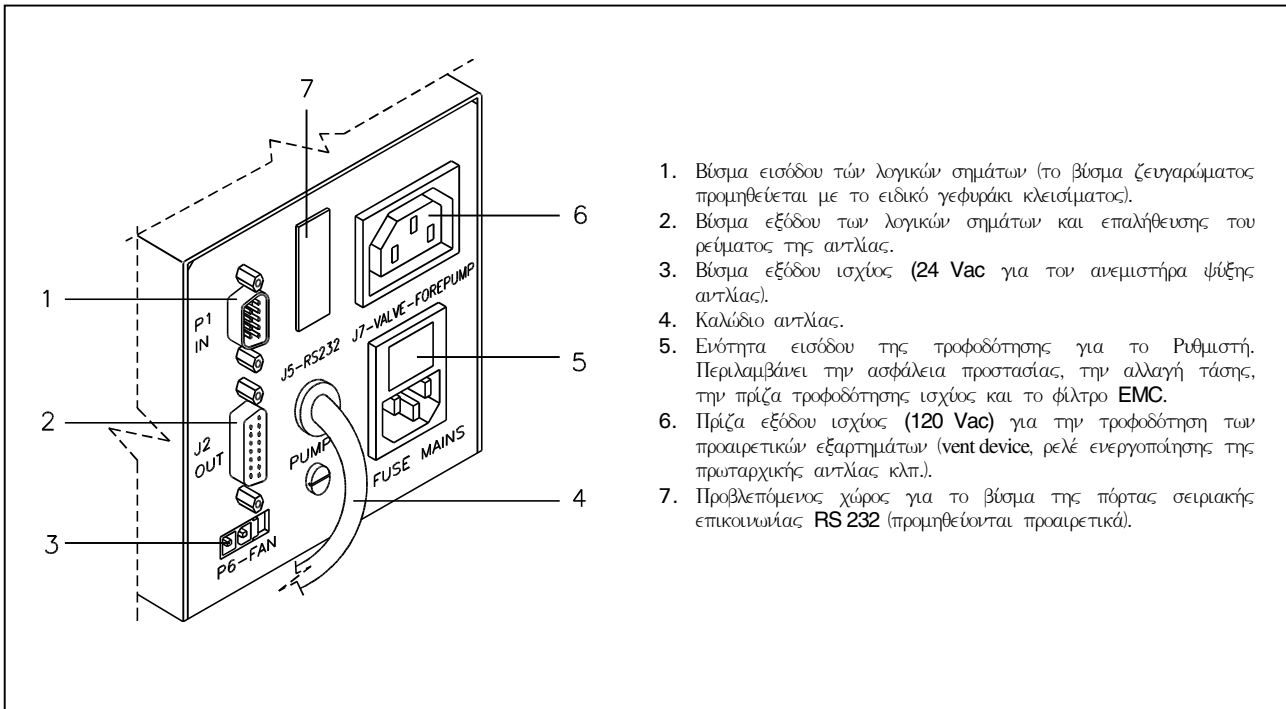

Εμπρόσθιος πίνακας του Ρυθμιστή 969-9405 και 969-9505

ΔΙΑΔΙΚΑΣΙΕΣ ΧΡΗΣΗΣ

Άναμμα του Ρυθμιστή

Για να ανάψει ο ρυθμιστής είναι αρκετό να βάλετε το καλώδιο τροφοδοσίας στην πρίζα του δικτύου.

Εκκίνηση της Αντλίας

Για να τεθεί σε κίνηση η αντλία θα πρέπει να πατήσετε το κουμπί **START** του εμπρόσθιου πίνακα.

1. Βύσμα εισόδου τών λογικών σημάτων (το βύσμα ζευγαρώματος προμηθεύεται με το ειδικό γεφυράκι κλεισίματος).
2. Βύσμα εξόδου των λογικών σημάτων και επαλήθευσης του ρεύματος της αντλίας.
3. Βύσμα εξόδου ισχύος (**24 Vac** για τον ανεμοστήρα ψύξης αντλίας).
4. Καλώδιο αντλίας.
5. Ενότητα εισόδου της τροφοδότησης για το Ρυθμιστή. Περιλαμβάνει την ασφάλεια προστασίας, την αλλαγή τάσης, την πρίζα τροφοδότησης ισχύος και το φίλτρο **EMC**.
6. Πρίζα εξόδου ισχύος (**120 Vac**) για την τροφοδότηση των προαιρετικών εξαρτημάτων (vent device, ρελέ ενεργοποίησης της πρωταρχικής αντλίας κλπ.).
7. Προβλεπόμενος χώρος για το βύσμα της πόρτας σειριακής επικοινωνίας **RS 232** (προμηθεύονται προαιρετικά).

Στάση της Αντλίας

Για να σταματήσει η αντλία αρκεί να πατήσετε το κουμπί **STOP** του εμπρόσθιου πίνακα.

ΣΥΝΤΗΡΗΣΗ

Οι ρυθμιστές της σειράς **Turbo-V 70** δεν απαιτούν καμία συντήρηση. Οποιαδήποτε επέμβαση θα πρέπει να πραγματοποιηθεί από εξουσιοδοτημένο προσωπικό.

Σε περίπτωση βλάβης μπορείτε να χρησιμοποιήσετε την υπηρεσία επισκευών της Varian ή το "Varian advance exchange service", που σας δίνει τη δυνατότητα να έχετε έναν αναζωογονημένο ρυθμιστή σε αντικατάσταση του χαλασμένου.

Για τη διάλυση του ρυθμιστή τηρήστε τις ισχύουσες εθνικές διατάξεις.



ΚΙΝΔΥΝΟΣ

Πριν κάνετε οποιαδήποτε επέμβαση στον Ρυθμιστή αποσυνδέστε το καλώδιο τροφοδοσίας.

ΜΗΝΥΜΑΤΑ ΛΑΘΟΥΣ

Σε ορισμένες περιπτώσεις βλάβης τα κυκλώματα αυτοδιάγνωσης του ρυθμιστή παρουσιάζουν ορισμένα μηνύματα λάθους τα οποία παρουσιάζονται στον πίνακα που ακολουθεί.

ΜΗΝΥΜΑ	ΠΕΡΙΓΡΑΦΗ	ΔΙΟΡΘΩΣΗ
CHECK CONNECTION TO PUMP	Κακή λειτουργία στη σύνδεση αντλίας και ρυθμιστή	Ελέγχετε αν το καλώδιο σύνδεσης μεταξύ αντλίας και ρυθμιστή είναι καλά σταθεροποιημένο και στα δύο άκρα και ότι δεν υπάρχει διακοπή. Πατήστε δύο φορές το κουμπί START για να θέσετε ξανά σε κίνηση την Αντλία.
PUMP WAITING INTERLOCK	Έχει ενεργοποιηθεί το σήμα interlock που βρίσκεται στο βύσμα P1 λόγω διακοπής του βραχυκυκλώματος μεταξύ του pin 3 και του pin 8 του βύσματος J1 , ή λόγω ανοίγματος του σήματος του εξωτερικού interlock .	Επαναφέρατε το βραχυκύκλωμα μεταξύ του pin 3 και του pin 8 του βύσματος J1 , ή κλείστε το σήμα του εξωτερικού interlock .
FAULT: ovERTIME SX	Κατά τη διάρκεια εκκίνησης της αντλίας με το " soft start ", η αντλία δεν έφτασε στην προβλεπόμενη ταχύτητα για κάθε στάδιο μισά σε 15 λεπτά. (Το X μπορεί να είναι από 0 ως 9 και δείχνει το στάδιο που δεν έχει ξεπεραστεί).	Ελέγχετε ότι το σύστημα δεν παρουσιάζει διαρροές. Πατήστε δύο φορές το κουμπί START για να θέσετε ξανά σε κίνηση την Αντλία.
FAULT: PUMP OVERTEMP.	Η θερμοκρασία του άνω κουζινιέτου της αντλίας ξεπέρασε τους 60 °C .	Περιμένετε ώσπου η θερμοκρασία να κατεβεί κάτω από το ανώτατο επιτρεπτό σημείο. Πατήστε δύο φορές το κουμπί START για να θέσετε ξανά σε κίνηση την Αντλία.
FAULT: CONTROLLER OVERTEMPERATURE	Η θερμοκρασία του μετασχηματιστή ξεπέρασε τους 90 °C .	Περιμένετε ώσπου η θερμοκρασία να κατεβεί κάτω από το ανώτατο επιτρεπτό σημείο. Πατήστε δύο φορές το κουμπί START για να θέσετε ξανά σε κίνηση την Αντλία.
FAULT: TOO HIGH LOAD	Κατά την κανονική λειτουργία (μετά τη φάση εκκίνησης) το απορροφούμενο ρεύμα από την αντλία είναι μεγαλύτερο από το προγραμματισμένο. (1,5 A).	Ελέγχετε αν ο ρότορας της αντλίας μπορεί να περιστραφεί ελεύθερα. Πατήστε δύο φορές το κουμπί START για να θέσετε ξανά σε κίνηση την Αντλία.
FAULT: SHORT CIRCUIT	Κατά την κανονική λειτουργία (μετά τη φάση εκκίνησης) η σύνδεση εξόδου έχει βραχυκυκλώσει (ρεύμα εξόδου μεγαλύτερο από 2,2 A).	Ελέγχετε τις συνδέσεις μεταξύ αντλίας και ρυθμιστή. Πατήστε δύο φορές το κουμπί START για να θέσετε ξανά σε κίνηση την Αντλία.
SYSTEM OVERRIDE	Η αντλία σταμάτησε από ένα σήμα κινδύνου που προέρχεται από την μακρινή επαφή.	Βγάλτε το καλώδιο τροφοδοσίας του ρυθμιστή και διορθώστε την αιτία πρόκλησης του σήματος κινδύνου. Επανασυνδέστε το καλώδιο τροφοδοσίας και πατήστε δύο φορές το Κουμπί START για να θέσετε ξανά σε κίνηση την αντλία.
OVERVOLTAGE	Παρουσιάστηκε βλάβη στον τομέα τροφοδοσίας του ρυθμιστή ή ο ρυθμιστής δέχθηκε ένα λανθασμένο σήμα.	Πατήστε δύο φορές το Κουμπί START για να θέσετε ξανά σε εκκίνηση την αντλία. Αν ξαναπαρουσιαστεί το μήνυμα απευθυνθείτε στην Varian για συντήρηση.
CONTROLLER FAILURE	Διακοπή ασφάλειας στο δευτερεύον ισχύος.	Απευθυνθείτε στη Varian για τη συντήρηση.

GENERAL INFORMATION

This equipment is destined for use by professionals. The user should read this instruction manual and any other additional information supplied by Varian before operating the equipment. Varian will not be held responsible for any events occurring due to non-compliance, even partial, with these instructions, improper use by untrained persons, non-authorized interference with the equipment or any action contrary to that provided for by specific national standards. The Turbo-V 70 series controllers are microprocessor-controlled, solid-state, frequency converter with self-diagnostic and self-protection features.

The controllers drive (within ten steps) the Turbo-V 70 pump during the starting phase by controlling the voltage and current respect to the speed reached by the pump.

They incorporate all the facilities required for the automatic operation of the Turbo-V 70 pump series. Remote start/stop, pump status signals, forepump start/stop, interlock control (for pressure switch, water flow switch, etc.) capability, are provided via auxiliary connectors.

The following paragraphs contain all the information necessary to guarantee the safety of the operator when using the equipment. Detailed information is supplied in the appendix "Technical Information".

This manual uses the following standard protocol:



WARNING!

The warning messages are for attracting the attention of the operator to a particular procedure or practice which, if not followed correctly, could lead to serious injury.



CAUTION!

The caution messages are displayed before procedures which, if not followed, could cause damage to the equipment.

NOTE

The notes contain important information taken from the text.

STORAGE

When transporting and storing the controllers, the following environmental requirements should be satisfied:

- temperature: from -20 °C to + 70 °C
- relative humidity: 0 - 95%
(without condensation)

PREPARATION FOR INSTALLATION

The controller is supplied in a special protective packing. If this shows signs of damage which may have occurred during transport, contact your local sales office. When unpacking the controller, ensure that it is not dropped or subjected to any form of impact. Do not dispose of the packing materials in an unauthorized manner. The material is 100% recyclable and complies with EEC Directive 85/399.

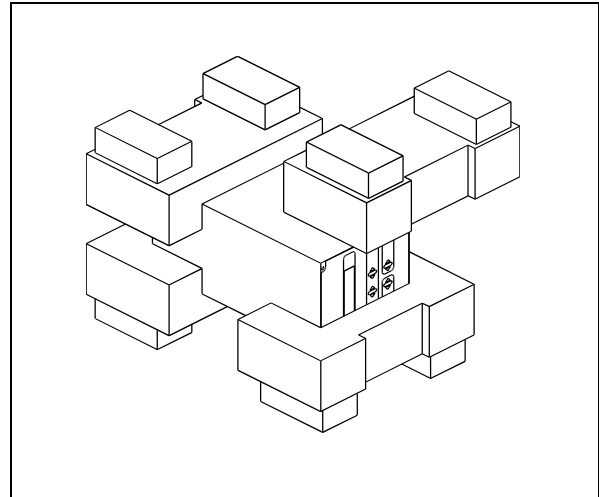

*Controller Packing
969-9405 and 969-9505*

Each controller is factory set for a specific power supply:

- model 969-9405 is factory set for 220 Vac operation
- model 969-9505 is factory set for 120 Vac operation

If a change in line voltage operation is desired, proceed as follows:

- Disconnect the power cord from the controller socket.
- On power entry module, check back door for voltage selector set.
- Using a small screw driver, pull out the voltage selector and fuses.
- Select the operating voltage then firmly insert the voltage selector and fuses in place.
- Check voltage selector window for correct set and connect power cord.

INSTALLATION



WARNING!

The Turbo-V controller is equipped with a 3-wire power cord and plug (internationally approved) for user's safety. Use this power cord and plug in conjunction with a properly grounded power socket to avoid electrical shock.

High voltage developed in the controller can cause severe injury or death. Before servicing the unit, disconnect the input power cable.

NOTE

The Turbo-V controller can be used as a bench unit or a rack module, but it must be positioned so that free air can flow through the holes. Do not install or use the controller in an environment exposed to atmospheric agents (rain, snow, ice), dust, aggressive gases, or in explosive environments or those with a high fire risk.

During operation, the following environmental conditions must be respected:

- temperature: from 0 °C to +40 °C
- relative humidity: 0 - 95% (without condensation)

To connect the controller to the pump use the specific cable supplied with the controller.

NOTE

The controllers model 969-9405 and 969-9505 are supplied with the pump cable fixed to the controller rear panel.

See the appendix "Technical Information" for detailed information about the above mentioned and the other connections, and about the options installation.

USE

This paragraph describes the fundamental operating procedures. Detailed information and operating procedures that involve optional connections or options are supplied in the paragraph "USE" of the appendix "Technical Information".

Make all vacuum manifold and electrical connections and refer to Turbo-V pump instruction manual prior to operating the Turbo-V controller.



WARNING!

To avoid injury to personnel and damage to the equipment, if the pump is laying on a table make sure it is steady. Never operate the Turbo-V pump if the pump inlet is not connected to the system or blanked off.

NOTE

The input signal J1 connector should be left in position including the shipping links if no external connections are made. The forepump and the Turbo-V pump can be switched on at the same time.

Controller controls, indicators and connectors

The following paragraph illustrates the Controller control panel and interconnection panel. More details are contained in the appendix "Technical Information".

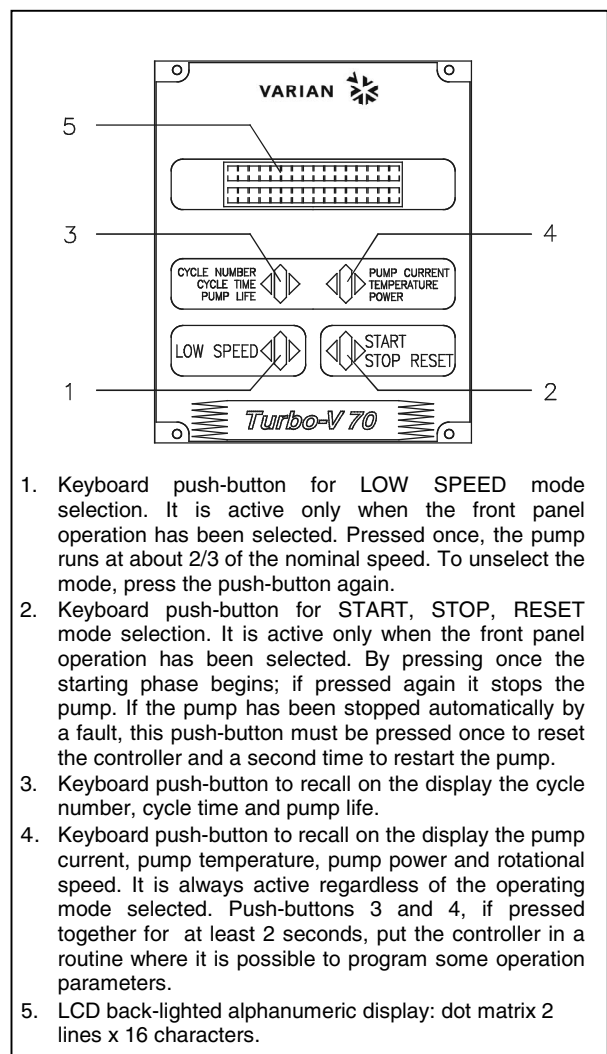

Controller 969-9405,
969-9505 Front Panel

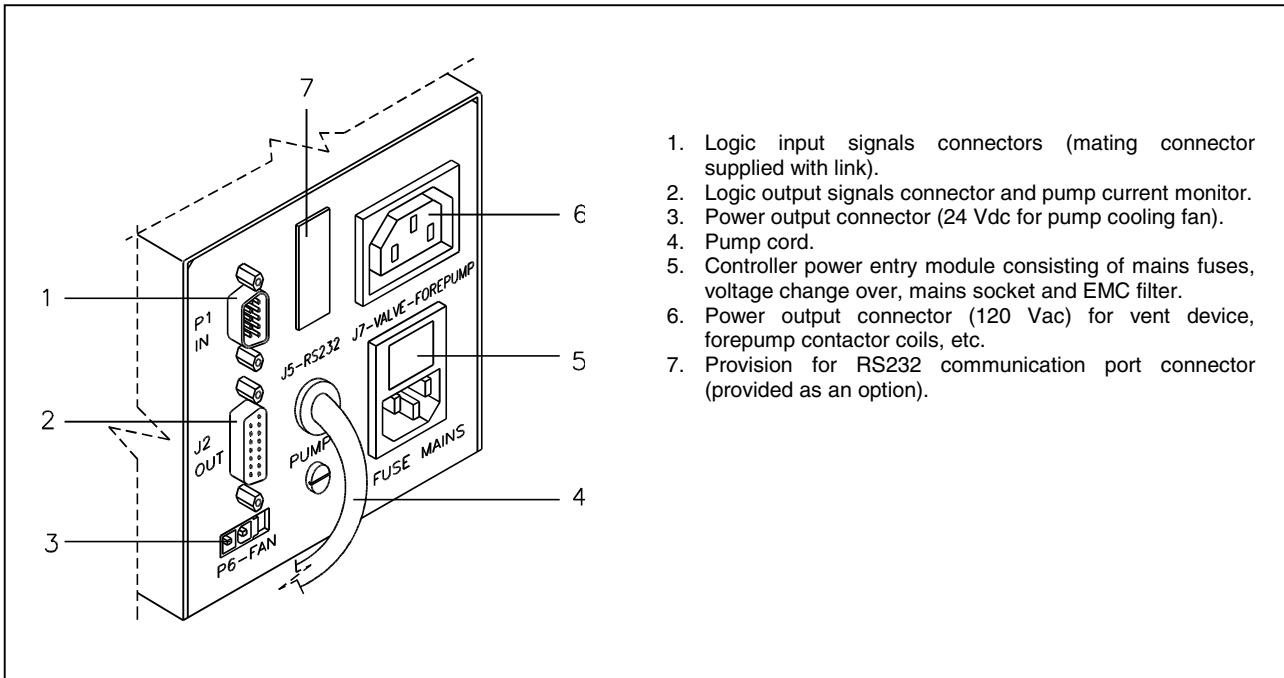

1. Logic input signals connectors (mating connector supplied with link).
2. Logic output signals connector and pump current monitor.
3. Power output connector (24 Vdc for pump cooling fan).
4. Pump cord.
5. Controller power entry module consisting of mains fuses, voltage change over, mains socket and EMC filter.
6. Power output connector (120 Vac) for vent device, forepump contactor coils, etc.
7. Provision for RS232 communication port connector (provided as an option).

Controller 969-9405 and 969-9505 Rear Panel

USE PROCEDURE

Controller Startup

To startup the controller plug the power cable into a suitable power source.

Starting the Pump

To start the pump press the START pushbutton on the controller front panel.

Pump Shutdown

To shutdown the pump press the STOP pushbutton on the controller front panel.

MAINTENANCE

The Turbo-V 70 series controller does not require any maintenance. Any work performed on the controller must be carried out by authorized personnel.

When a fault has occurred it is possible to use the Varian repair service. Replacement controllers are available on an advance exchange basis through Varian.

If a pump is to be scrapped, it must be disposed of in accordance with the specific national standards.



WARNING!

Before carrying out any work on the controller, disconnect it from the supply.

ERROR MESSAGES

For a certain type of failure, the controller will self-diagnose the error and the messages described in the following table are displayed.

MESSAGE	DESCRIPTION	REPAIR ACTION
CHECK CONNECTION TO PUMP	Wrong connection between the pump and the controller.	Check connection between controller and pump. Press the START push-button twice to start the pump.
PUMP WAITING INTERLOCK	The interlock signal of P1 connector is activated by an interruption of the link between pin 3 and 8 of J1 connector, or because the external interlock signal is open.	Reset the short circuit between pin 3 and pin 8 of J1 connector, or close the external interlock signal.
FAULT: OVERTIME SX	Within each step of the soft start mode the rotational speed of the pump does not reach the planned value within 15 minutes. (X) is the step number from 0 to 9 indicating the step number not passed).	Verify that system has no leaks. Press the START pushbutton twice to start the pump.
FAULT: PUMP OVERTEMP.	The upper bearing/pump temperature exceeds 60 °C.	Wait until the temperature decrease below threshold value. Press the START push-button twice to start the pump.
FAULT: CONTROLLER OVERTEMPERATURE	The controller transformer temperature exceeds 90 °C.	Wait until the temperature decrease below threshold value. Press the START push-button twice to start the pump.
FAULT: TOO HIGH LOAD	In normal operation (after the starting phase) the current drawn by the pump is higher than programmed (1.5 A)	Check that the pump rotor is free to rotate. Press the START push-button twice to start the pump.
FAULT: SHORT CIRCUIT	After the starting phase the output connection is shorted (output current higher than 2.2 A).	Check connections and shortages between pump and controller. Press the START push-button twice to start the pump.
SYSTEM OVERRIDE	The pump is stopped by an emergency stop signal provided via a remote contact.	Remove the controller power cable and check the emergency condition. Then reconnect the power cable and press the START push-button twice to start the pump.
OVERVOLTAGE	Controller power supply circuitry is faulty, or the Controller received a spike.	Press the START push-button twice to start the pump. Should the message still be present, call the Varian service.
CONTROLLER FAILURE	Fuse blown on the power supply secondary of the transformer.	Contact Varian for Maintenance.

TURBO-V 70 CONTROLLER DESCRIPTION

The controller is available in two versions which differ only in the factory-set input voltage:

- Model 969-9405 (220 Vac, 50-60 Hz)
- Model 969-9505 (120 Vac, 50-60 Hz)

The controller is a solid-state frequency converter which is driven by a single chip microcomputer and is composed of:

- Power transformer
- Front panel display and keyboard
- Rear panel with input/output connectors
- PCB including: power supply and 3-phase output, analog and input/output section, microprocessor and digital section, display and keyboard circuits.

The power supply converts the single phase (50-60 Hz) AC mains supply into a 3-phase, low voltage, medium frequency output which is required to power the Turbo-V pump.

The microcomputer generates the variable output frequency and controls the 3-phase output voltage according to the software and the gas load condition of the pump.

Moreover, it manages signals from sensors, input/output connection information to be displayed, and gives outputs for a fully automatic operation.

A dedicated non-volatile RAM is used to store pump operating parameters and the input/output programmed information upon failure for a period of 10 years accumulated off time.

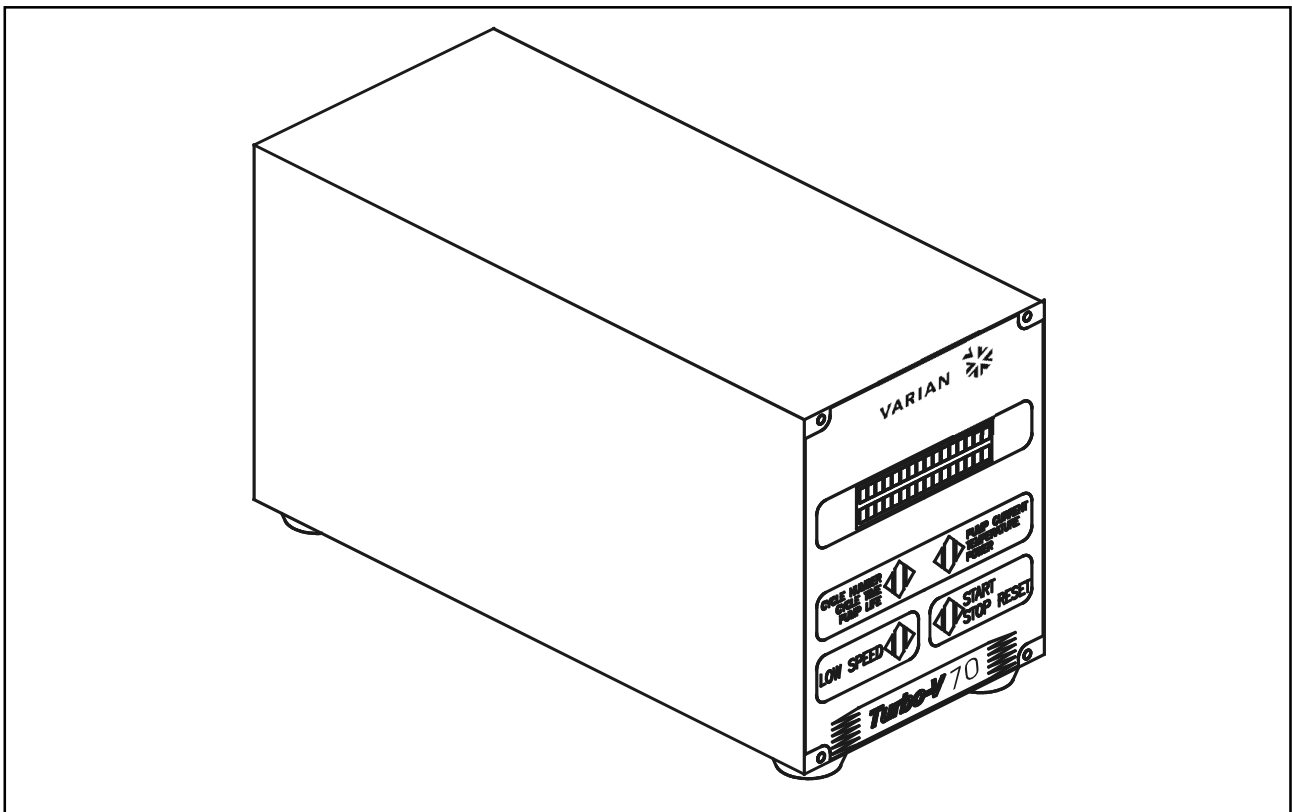

Turbo-V 70 Controller

CONTROLLER SPECIFICATIONS

Input:	
Voltage	100, 120, 220, 240 Vac ±10%,
Frequency	1-phase
Power	47 to 63 Hz 350 VA maximum
Output:	
Voltage	54 Vac nominal ±10%, 3-phase
Frequency	1250 Hz, ±2%
Power	150 W maximum
Operating temperature	0 °C to +40 °C
Storage temperature	-20 °C to +70 °C
Fuse (mains)	2 x T3.15 A (slow blow) disregarding the mains
P1 optoisolator input	Minimum ON 3 mA Maximum 5 mA
J2 optoisolator output	24 Vdc, 60 mA

Radio interference suppression	EN 55011 class A group 1 EN 61010-1 IEC1000-4-2, 1000-4-3, 1000 4-4
P6 output fan	100 mA (24 Vdc)
J7 output (forepump coil, etc.)	120 Vac, 1 A disregarding the mains
Interconnecting cables	Mains cable (3-wire, 3-meter long) Pump cable (6-wire, 5-meter long)
Weight:	3.8 Kg (8.4 lbs)

CONTROLLER OUTLINE

The outline dimensions for the Turbo-V 70 controllers are shown in the following figure.

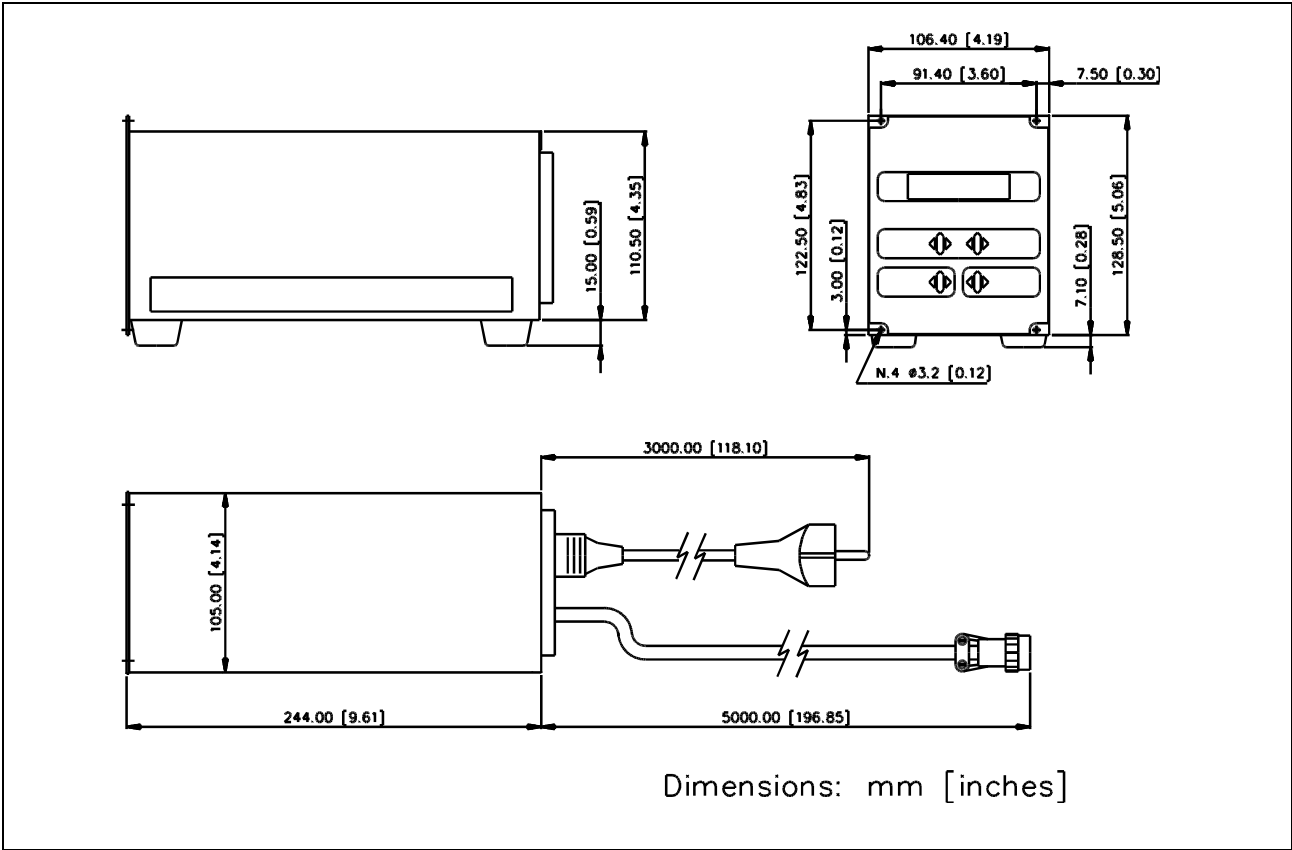

Dimensions: mm [inches]

Controller outline

Inspect the controller for any shipping damage.

The Turbo-V 70 controller model 969-9405 is factory-set for 220 Vac operation and model 969-9505 is factory-set for 120 Vac operation.



WARNING!

The Turbo-V controller is equipped with a 3-wire power cord and plug (internationally approved) for user's safety. Use this power cord and plug in conjunction with a properly grounded power socket to avoid electrical shock.

High voltage developed in the controller can cause severe injury or death. Before servicing the unit, disconnect the input power cable.

NOTE

The Turbo-V controller can be used as a bench unit or as a rack module, but it must be positioned so that free air can flow through the holes.

Line Voltage Change Over

If a change in line voltage operation is desired, proceed as follows:

- Disconnect the power cord from the controller socket.
- On power entry module, check back door for voltage selector set.
- Using a small screw driver, pull out the voltage selector and fuses.
- Select the operating voltage, then firmly insert the voltage selector and fuses in place.
- Check voltage selector window for correct set and connect the power cord.

POWER INTERCONNECTIONS

Connection J7 - 120 Vac Connector

The 120 Vac, 1A maximum (independent of line voltage) output voltage is present after START pushbutton is pressed and will remain present until a fault condition is displayed on the front panel display or the turbopump is stopped.

To make connections, remove the plug and wire the pins (maximum wire size 18 AWG, 1 mm²) as indicated in the following figure to obtain the desired capability.

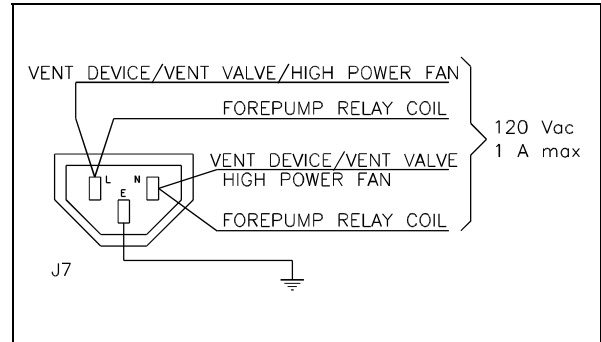

J7 connector output power



CAUTION!

On the J7 outlet the output voltage is 120 Vac with the maximum current of 1 A.

If more than one device is connected, be sure to draw not more than 120 VA to avoid controller damage. Use a relay coil with a maximum surge power of 65 VA.

NOTE

Forepump relay coil is an independent, user supplied item.

Connection P6 - 24 Vdc Connector

The 24 Vdc, 100 mA maximum output voltage is present after START pushbutton is pressed and will remain present until a fault condition is displayed on front panel display or the turbopump is stopped. This is a dedicated output for the optional Turbo-V 70 pump cooling fan.

The mating connector and cable are provided assembled with the air cooling kit.

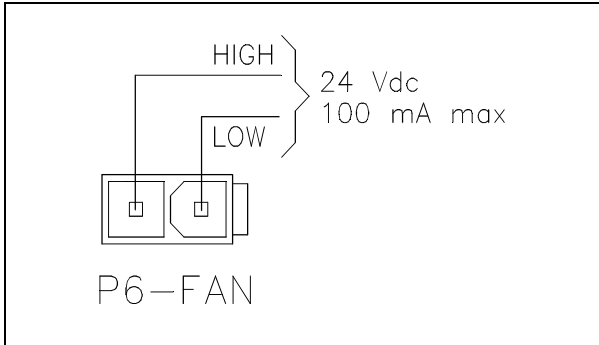

Fan Connector

LOGIC INTERCONNECTIONS

Connection P1 - Logic Input Interconnections

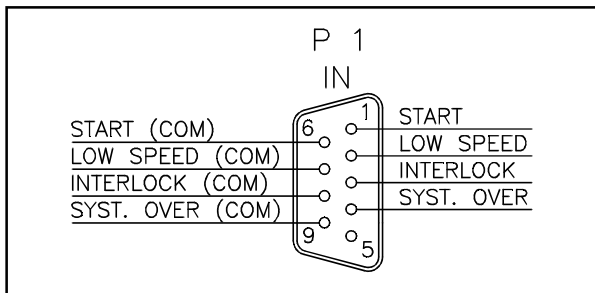

P1 input connector

All the logic input to the controller **must** be connected at J1 mating connector.

With the provided J1 mating connector (shipped with pin 3 and pin 8 shorted) make the connections with AWG 24, (0.24 mm²) or smaller wire to the pins indicated in the figure to obtain the desired capability.

The following table describes the signals available on the connector.

PIN	DESCRIPTION
1-6	Remote START/STOP optically isolated from the internal circuit, requires a permanently closed contact (relay contact, transistor, etc.). When the contact closes, the turbopump starts, and when the contact opens, the turbopump is stopped. With the remote mode operation selected, the front panel push-button is inoperative.
2-7	Remote LOW SPEED optically isolated from the internal circuit, requires a permanently closed contact (relay contact, transistor, etc.). When the contact closes, the turbopump runs at low speed and when the contact opens, the turbopump reverts to high speed mode. With the remote mode operation selected, the front panel push-button is inoperative.
3-8	INTERLOCK optically isolated from the internal circuit, this signal can be used to delay the starting of the turbopump. It requires a permanent closed contact before starting the turbopump.
4-9	SYSTEM OVERRIDE optically isolated from the internal circuit, this signal is used to stop the pump in emergency condition, requires a closed contact. When the contact is closed, the turbopump and the interconnected devices are stopped.

NOTE

Pin 3-8 must be shorted to allow the Turbo-V 250 PCB pump to start if no interlock contact is connected. If, after starting the pump, the interlock contact opens, it has no effect on the operation and the pump continues to turn.

The following figure shows a typical contact logic input connection and the related simplified circuit of the controller.

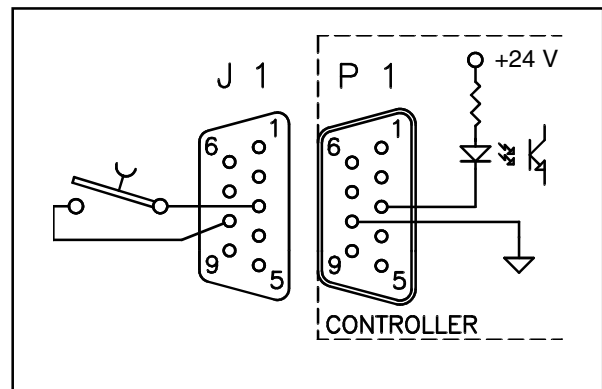

Typical logic input connection

Connection J2 - Logic Output Interconnections

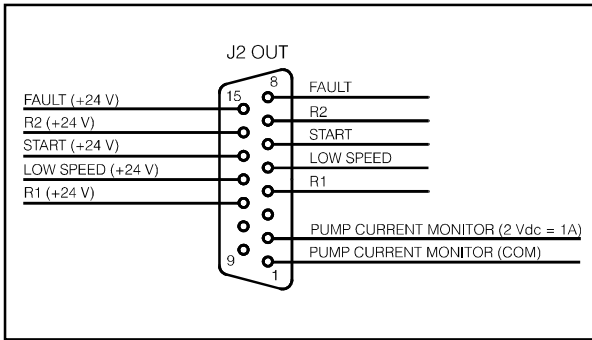

Logic output connector

All the logic output from the controller must be connected at P2 mating connector. With the optional P2 mating connector make the connection with AWG 24 (0.25 mm²) or smaller wire to the pins indicated in the figure to obtain the desired capability. The following table describes the signals available on the connector.

PIN	DESCRIPTION
1-2	Analog output Voltage of DC power drawn by the turbopump (pin 2 positive, pin 1 negative). 2 Vdc \approx 1 A.
4-11	R1 signal 24 V, 60 mA, optically isolated output (pin 11 positive, pin 4 negative). The output voltage will be present when the rotational speed of the pump is higher than the selected speed threshold.
5-12	LOW SPEED signal, 24 V, 60 mA, optically isolated output (pin 12 positive, pin 5 negative). The output voltage will be present when the low speed mode is selected, either through the front panel, the remote signal or RS 232.
6-13	START signal 24 V, 60 mA, optically isolated output (pin 13 positive, pin 6 negative). The output voltage will be present when the START push-button on front panel is pressed, or the remote start is present, or the function has been requested by RS 232, until NORMAL operation is reached.

PIN	DESCRIPTION
7-14	R2 signal 24 V, 60 mA, optically isolated output (pin 14 positive, pin 7 negative). The output Voltage will be present upon the programmed condition delay YES or delay NO (see the cycle diagram in the following pages). If YES is selected, R2 is off and the output is zero over all run up time, then: a) If running speed > speed threshold R2 = OFF b) If running speed < speed threshold R2 = ON If NO is selected: a) If running speed > speed threshold R2 = OFF b) If running speed < speed threshold R2 = ON
8-15	FAULT signal 24 V, 60 mA, optically isolated output (pin 15 positive pin 8 negative). The output Voltage will be present when a fault condition is displayed on the front panel display.

The following figure shows a typical logic output connection (relay coil) but any other device may be connected e.g. a LED, a computer, etc., and the related simplified circuit of the controller.

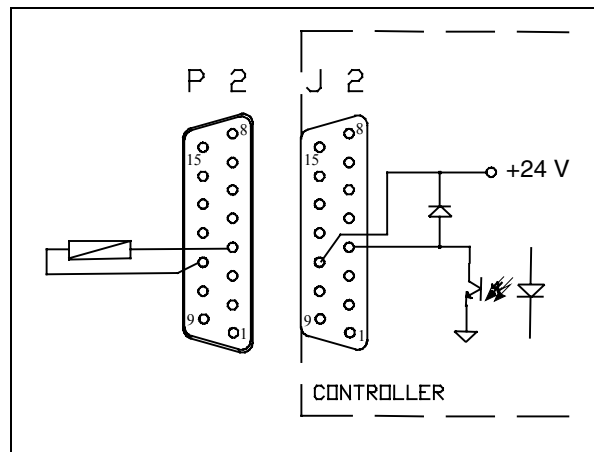

Typical output connection

Controller-to-Pump Connection

A five-meter long cable is provided to connect the controller to the pump. The following figures show the controller output connector configuration where pins:

- A-F = pump temperature sensor
- B-C-D = 54 Vac 3-phase output to pump motor stator
- E = ground

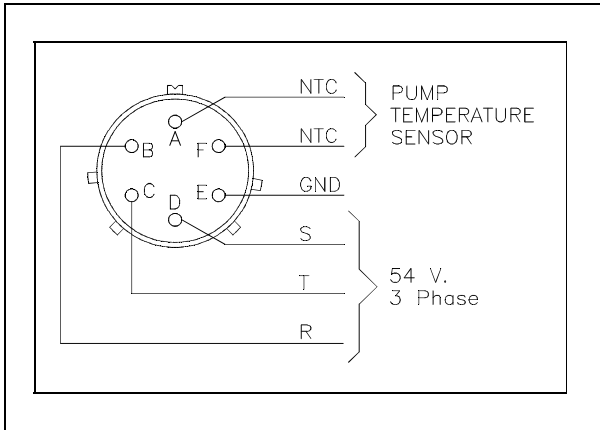

Controller-to-pump connector

RS 232 OPTION

RS 232 Installation

To install it, proceed as follows:

- Switch off the power and disconnect the power cord.
- Unscrew the cover screws and remove the cover.
- On rear panel, remove the J5 connector plate.
- Insert the flat cable through the rear panel and plug it into the socket located on the internal board of the controller.
- Install and tighten the connector screws.
- Replace the cover.

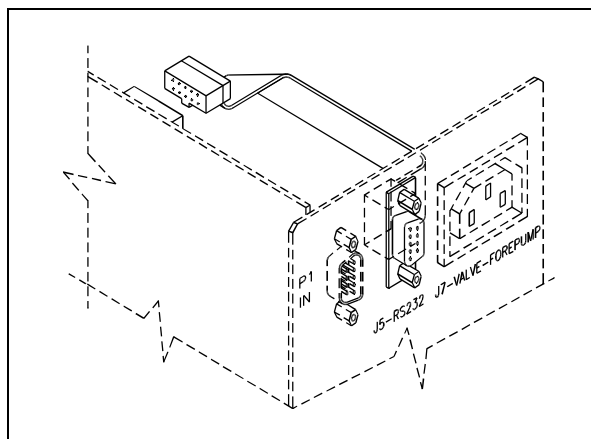

RS 232 connector installation

RS 232 Communication Port

The communication serial port connections and the minimum connection configuration are shown in the following figures.

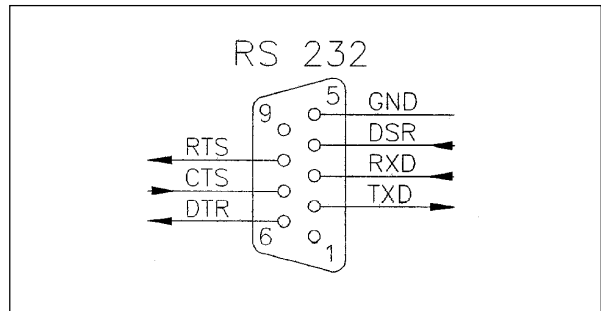

Communication serial port connections

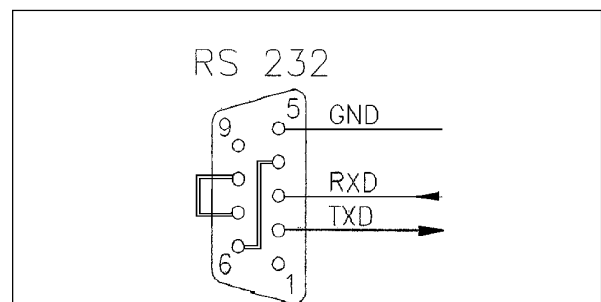

Minimum connection configuration

The communication port mating connector is supplied with the RS 232 PCB (AMP/Cannon or equivalent 15-pin "D" type male connector).

The external cable (not supplied) between the host computer and the controller doesn't require any crossed wires so that the signal are connected correctly.

For example, the Transmit data signal from controller (pin 2) must be connected to the host computer's Receive data line (pin 2) and vice versa. Consult the host computer's instruction manual for its serial port connections.

NOTE

Varian cannot guarantee compliance with FCC regulations for radiated emissions unless all external wiring is shielded, with the shield being terminated to the metal shroud on the 0-subconnector. The cable should be secured to the connector with screws.

RS 232 Communication Descriptions

Communication format:

- 8 data bit
- no parity
- 1 stop bit
- The baud rate is programmable via front panel from 600 to 9600 baud. The controller is factory-set for 9600 baud operation.

NOTE

When a baud rate of 2400, 4800, 9600 baud is used, the requested information from Host to controller must be sent with a minimum interval of 1 second to avoid the controller hang-up.

Communication protocol:

Host = Master

Turbo-V 70 Controller = Slave

The communication is performed in the following way:

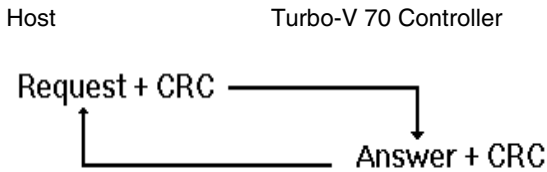

Request is an ASCII character identifying the action that must be performed by the controller or the requested information.

Allowed ASCII characters:

- "A" = START
- "B" = STOP
- "C" = Low Speed ON
- "D" = Low Speed OFF
- "E" = Request for operational parameters
- "F" = Pump times zeroing
- "G" = Parameters reading
- "H" = Parameters writing
- "I" = Request for operating status
- "J" = Request for numerical reading
- "K" = Request for counters reading.

CRC corresponds to the sum (with inverted sign) of all the preceding bytes.

e.g., the START command "A" in ASCII code = 41; inverted it will be: FF + 1 - 41 = BF.

CHARACTER	ASCII	CONVERTED ASCII FOR CRC CALCULATION
"A"	41h	-
CRC	-	BFh
"B"	42h	-
CRC	-	BEh
"C"	43h	-
CRC	-	BDh
"D"	44h	-
CRC	-	BCh
"E"	45h	-
CRC	-	BBh
"F"	46h	-
CRC	-	BAh
"G"	47h	-
CRC	-	B9h
"H"	48h	-
"I"	49h	-
CRC	-	B7h
"J"	4Ah	-
CRC	-	B6h
"K"	4Bh	-
CRC	-	B5h
"ACK"	06h	-
CRC	-	FAh
"NACK"	15h	-
CRC	-	EBh

Answer = after a request from the host, the Turbo-V 70 controller will answer in one of the following ways:

- ACK
- NACK
- Message

When the Request is "A", "B", "C", "D", "F", the Turbo-V 70 controller will Answer the ACK or NACK.

When the Request is "E", the **Answer** will contain the complete set of the following parameters:

BYTES	MEANING
<div style="text-align: center;"> 1 MSB LSB ---- X X X X </div>	0 = STOP 1 = WAITING INTERLOCK 2 = STARTING 3 = NORMAL OPERATION 4, 5 = HIGH LOAD 6 = FAILURE 7 = APPROACHING LOW SPEED
2 ÷ 5	Cycle Time
6 ÷ 9	Pump Life
10 ÷ 11	Pump Temperature
12	Current*
13	Voltage*
14 ÷ 17	Frequency
18 ÷ 19	Cycle #
20	R1 Status
21	R2 Status
22	CRC

*The values for current and voltage are given as numbers, scaled from 0 to 255, where 0 corresponds to 0 V and 255 to the full scale voltage (75 V) or current (2.5 A).

When the **Request** is "G", the **Answer** will contain a string of 11 characters with the following parameters:

BYTES	MEANING
1-2	Pump cycles number (integer coded in 2 bytes)
3	Speed threshold
4-7	Run up time in seconds (long coded in 4 bytes)
8	Deat time (0 = NO 1 = YES)
9	Soft Start mode (0 = NO 1=YES)
10	Water cooling (0 = NO 1=YES)
11	CRC

When the configuration parameters have to be changed, send a **Request** string a string with 9 characters of the following type:

"H" + data + CRC

The following parameters can be changed:

BYTES	MEANING
1	Speed threshold
2-5	Run up time in seconds (long coded in 4 bytes)
6	Deat time (0 = NO 1 = YES)
7	Controller OFF when R2 OFF (0 = NO 1 =YES)
8	Soft Start mode (0 = YES 1 = NO)
9	CRC

When the **Request** is "I" (Status readings), the **Answer** will contain a string of 2 characters with the following parameters:

BYTES	MEANING
<div style="text-align: center;"> 1 MSB LSB -- X X X X X X </div>	0 = STOP 1 = WAITING INTERLOCK 2 = STARTING 3 = NORMAL OPERATION 4, 5 = HIGH LOAD 6 = FAILURE 7 = APPROACHING LOW SPEED R2 status 0 = OFF 1 = ON R1 status 0 = OFF 1 = ON
2	CRC

When the **Request** is "J" (Numerical readings), the **Answer** will contain a string of 5 characters with the following parameters:

BYTES	MEANING
1	Current (0-255 scaled)
2	Voltage (0-255 scaled)
3	Rotational speed KRPM
4	Pump temperature °C (0-254 temperature reading, 255 = fail)
5	CRC

When the **Request** is "K" (Counters readings), the **Answer** will contain a string of 11 characters with the following parameters:

BYTES	MEANING
1-4	Cycle time
5-8	Pump life
9-10	Cycle number
11	CRC

On request a sample program in QBasic language is available by Varian.

USE

General

Make all vacuum manifold and electrical connections and refer to Turbo-V pump instruction manual before to operating the Turbo-V controller.



WARNING!

To avoid injury to personnel and damage to the equipment, if the pump is laying on a table make sure it is steady. Never operate the Turbo-V pump if the pump inlet is not connected to the system or blanked off.

NOTE

The input signal P1 connector should be left in position including the shipping links if no external connections are made. The forepump and the Turbo-V pump can be switched on at the same time.

NOTE

When the Turbo-V 70 pump is baked by a membrane pump, the Soft Start mode should be deselected.

Startup

- Plug the controller power cable into a suitable power source.
- The display lights, and shows:

R	E	A	D	Y	F	O	R	L	O	C	A	L		
S	O	F	T		S	T	A	R	T					

The controller with the Soft Start mode allows the pump to ramp-up to Normal speed slowly with a minimum ramp-up time of 75 seconds and a maximum of about 45 minutes.

The Soft Start mode is always operative as default mode. If it is necessary to deselect this mode refer to the following paragraph.

If the Soft Start mode is deselected, the ramp-up will be done within 75 seconds and the display changes as follows:

P	U	M	P	R	E	A	D	Y	:		P	U	S	H
	S	T	A	R	T	B	U	T	T	O	N			

NOTE

If the pump is not connected, the display will be as follows:

C	H	E	C	K	C	O	N	N	E	C	T	I	O	N
			T	O	P	U	M	P						

NOTE

After pressing the START pushbutton, if the P1 connector is not in place with the link or the external interlock connections are open, the display will be as shown in the following figure.

Unplug the controller power cable and verify the P1 connection according to the previous Section.

P	U	M	P	W	A	I	T	I	N	G				
I	N	T	E	R	L	O	C	K						

- Press the **CURRENT** push-button and the display shows:

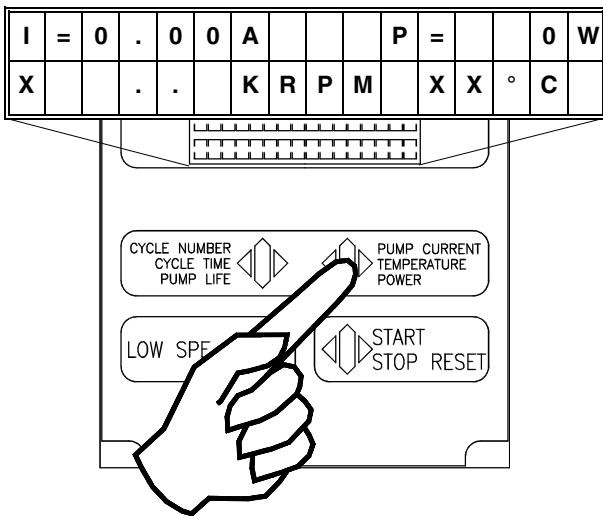

where:

- **I** = is the DC current drawn by the pump range (0.00 to 2.50 Ampere)
- **P** = is the DC power drawn by the pump (range 0 to 999 Watt)
- **KRPM** = is the theoretical rotational speed of the pump as a function of the controller output frequency (range 9 to 75 KRPM)
- **°C** = is the temperature of the outer ring of the upper bearing (range 00 to 99 °C)
- **X** = during operation a selected set point condition (1 or 2 contrast inverted) appears when the programmed threshold speed value is not reached.

- Press the **CYCLE NUMBER** twice and the display shows:

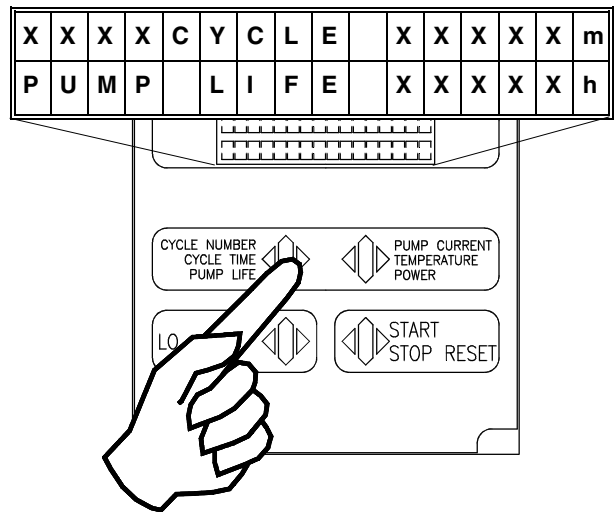

where:

- **CYCLE** = are the cycles performed (range 0 to 9999)
- **m** = is the elapsed time related to the cycle number displayed (range 0 to 99999 minutes)
- **PUMP LIFE** = is the total operation time of the pump (range 0 to 99999 hours).

FRONT / REMOTE/ 232 Selection

- Press **CYCLE NUMBER** and **PUMP CURRENT** push-buttons together for at least 2 seconds and the processor enters in a routine where it is possible to program the controller. In this routine, the **CYCLE** push-button is used for choosing/changing the value or condition; the **PUMP CURRENT** push-button is used to enter and confirm the value. At any time it is possible to exit this routine by pressing the **CYCLE** and **PUMP CURRENT** push-buttons at the same time for at least 2 seconds. The display shows:

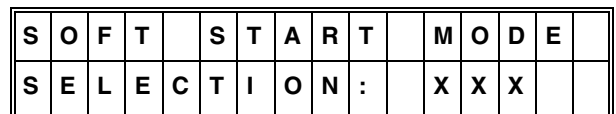

where: **XXX** = YES or NO.

If YES is selected, the Soft Start mode allows the pump to ramp-up the Normal speed within ten steps. When NO is selected, the Soft Start mode is deselected and the ramp-up of the pump will be done within 75 seconds. The controller is factory set to YES.

NOTE

The Soft Start mode may be deselected/selected only when the pump is stopped.

If necessary press CYCLE NUMBER to select YES or NO, then enter the selection by pressing the PUMP CURRENT pushbutton.

The display shows:

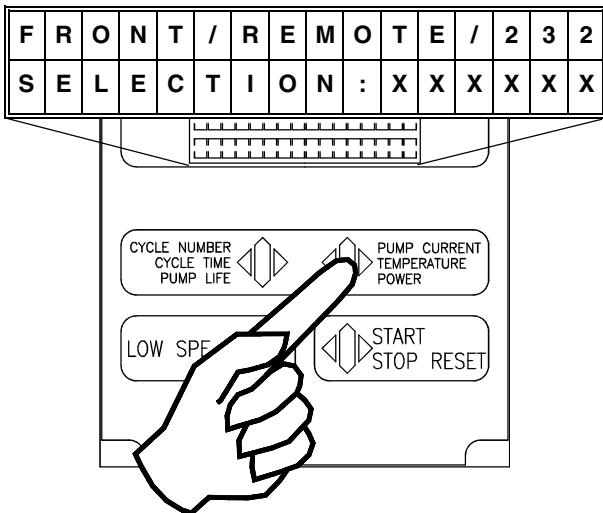

where: **XXXXXX** = means the word FRONT or REMOTE, or RS 232 depending on the last selection. The controller is factory-set for FRONT panel operation.

After choosing the desired selection by pressing the CYCLE pushbutton, press the PUMP CURRENT pushbutton to enter the value.

The display shows:

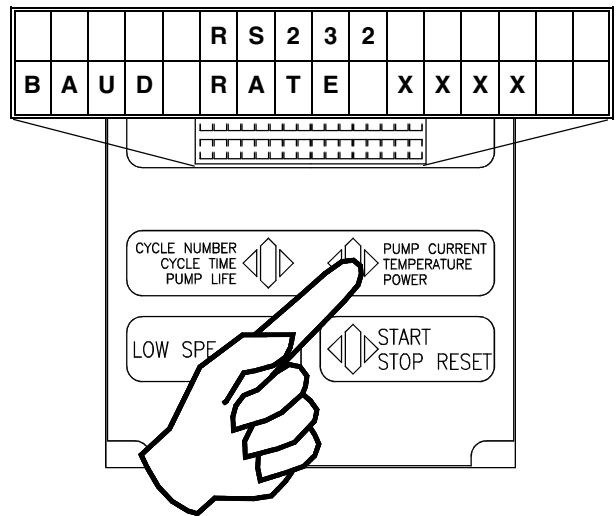

where: **XXXX** = means 600, 1200, 2400, 4800, 9600 baud rate for the host computer or printer communication. The controller is factory-set for 9600 baud rate operation.

If necessary, select the desired value by pressing the CYCLE NUMBER, then enter the value by pressing the PUMP CURRENT pushbutton.

The display shows:

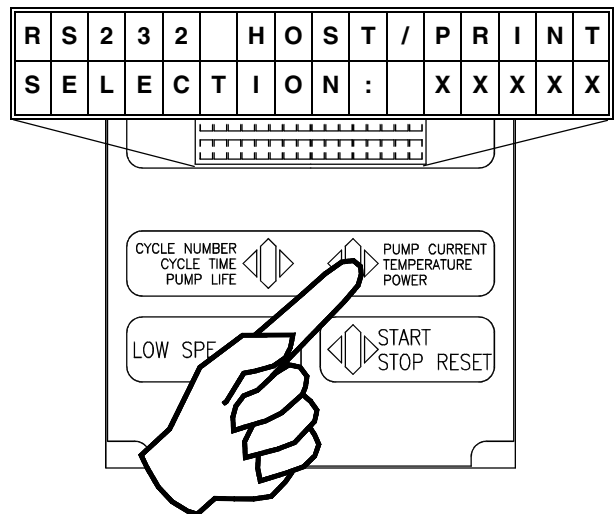

where: **XXXX** == means HOST or PRINT.

Select HOST or PRINT by pressing the CYCLE pushbutton.

With the RS 232 connected, a bidirectional communication is established by selecting HOST. Data are sent to an external computer every time the external computer asks for the values.

The data available are:

- Pump/controller operating condition
- Cycle time
- Pump life
- Pump temperature
- Pump current
- Pump voltage
- Controller output frequency
- Cycle number
- R1 condition
- R2 condition
- Life time and cycle # zeroing
- Configuration parameter readings
- Configuration parameter setting

If PRINT is selected and a printer is connected on RS 232 line, a unidirectional communication is established and every minute the data are sent to the printer, even if the pump is not running.

The set of data available are:

- Pump speed KRPM
- Pump temperature
- Pump current A
- Pump power W
- R1 condition
- R2 condition

The controller is factory-set to HOST.

- Confirm the selection by pressing the PUMP CURRENT push-button.
- In this way you enter into an operating phase named "Monitor Relay Programming" described in the following paragraph.

Monitor Relay Programming

- The display shows:

S	P	E	E	D		T	H	R	E	S	H	O	L	D	
S	E	L	E	C	T	I	O	N	:	X	X	K	R	P	M

where: **XXKRPM** = is the switch point of relay R1 at the preset turbopump speed, adjustable from 00 to 99 KRPM.

The speed threshold will condition the R1 and R2 operation (see the following cycle diagram) and it is factory-set to 67 KRPM.

The speed threshold will condition the R1 and R2 operation and it is factory-set to 67 KRPM.

Select the first number by pressing the CYCLE NUMBER push-button, then enter the value by pressing the PUMP CURRENT push-button.

Do the same for the second number. After pressing the PUMP CURRENT the second time, the display will be as shown in the following figure.

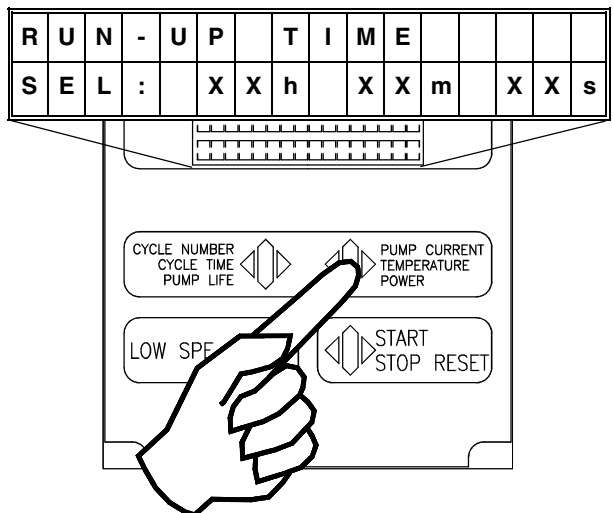

where: **RUN-UP TIME** = is the interval time from start to speed threshold value in hours, minutes, seconds. Select from 00 to 99 hours, and from 00 to 59 minutes or seconds.

Select the run-up time according to the chamber volume and/or operating cycle feature by pressing the CYCLE NUMBER push-button to select the desired number, then press the PUMP CURRENT push-button to enter the data.

The run up time is factory-set to:
00h 08m 00s.

When the last digit is entered, the display will be as shown in the following figure.

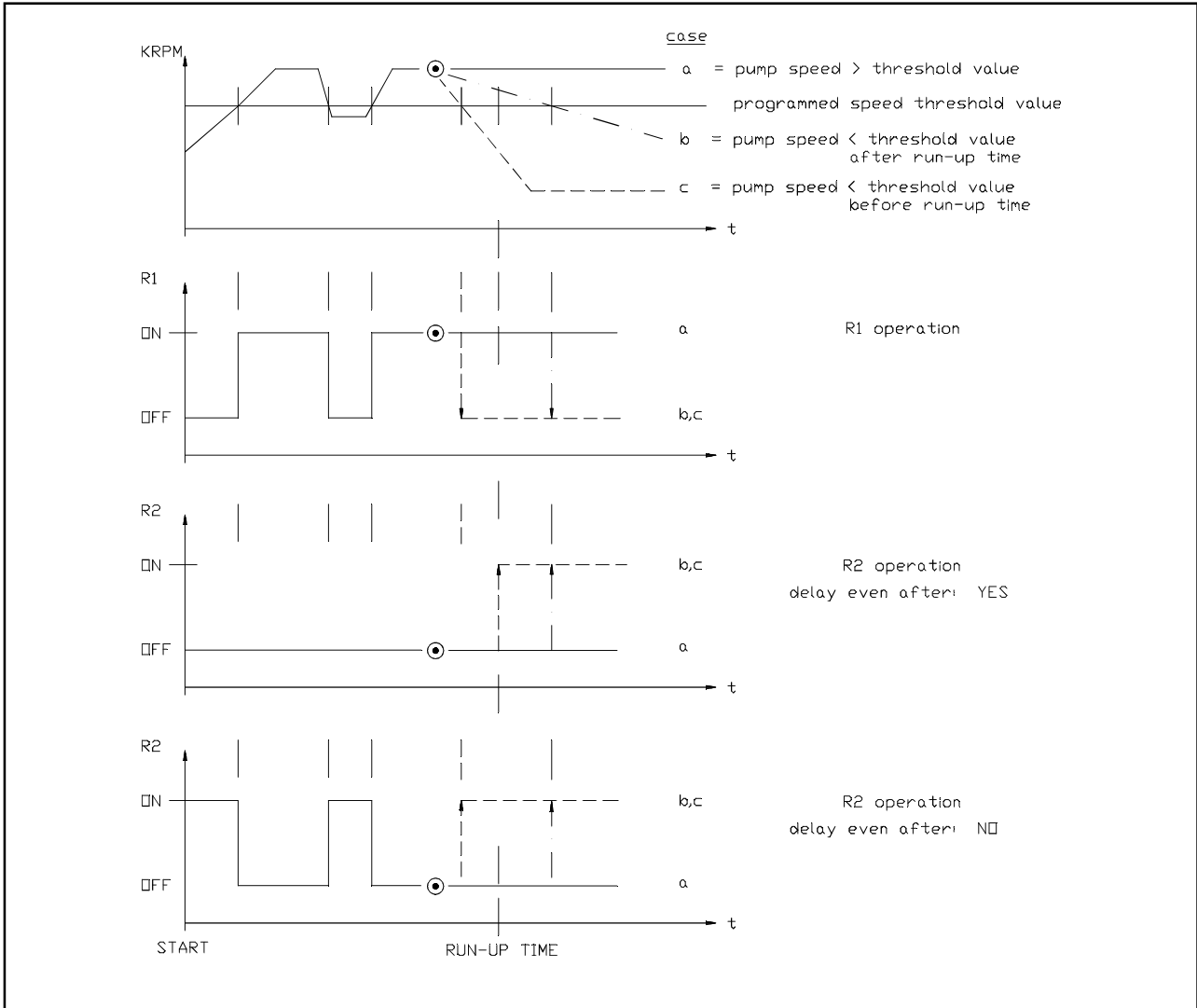

Cycle diagram

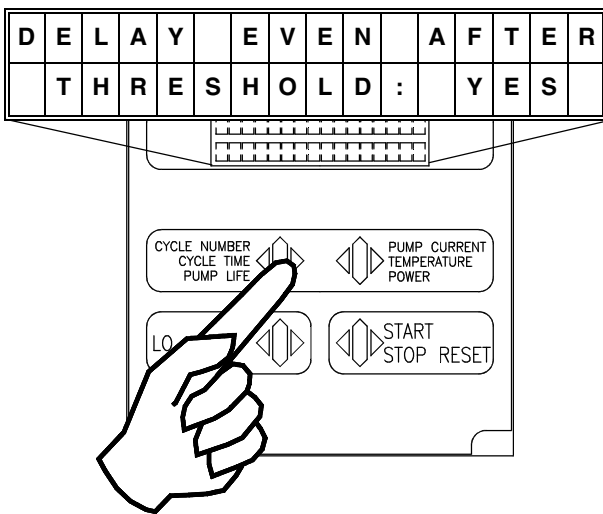

where:

XXX = YES or NO.

By pressing the CYCLE NUMBER push-button, select YES if relay R2 must operate only after the run-up time or select NO when the R2 operation is needed right from start of the turbopump and after the rotational speed of the turbopump exceeds for the first time the speed threshold value.

This function is factory-set to YES.

After selection, press PUMP CURRENT to confirm; the display will be as shown in the following figure.

Reset Command

- The display shows:

P	U	M	P		L	I	F	E		X	X	X	X	X	h
			R	E	S	E	T	?		X	X	X			

where:

- PUMP LIFE** = is the elapsed operating time range 000 to 99999 hours.
- RESET XXX** = YES or NO.

If YES is selected, the pump life shall be reset to 000. After selecting YES, press the PUMP CURRENT push-button to enter the command and the display shows as follows.

The controller is factory-set to NO.

NOTE

When PUMP LIFE is reset to 000, the CYCLE number is also reset to 000.

Starting the Pump

If the forepump and vent device are not operated by the controller, close the vent valve and switch on the forepump.

NOTE

With the FRONT panel operation selected, the REMOTE and RS 232 operations are inoperative; conversely, the CYCLE NUMBER and PUMP CURRENT push-buttons are always active, even when the operating mode selected is REMOTE or RS 232.

- Press the START push-button (or use the remote or RS 232 start signal), and the display shows:

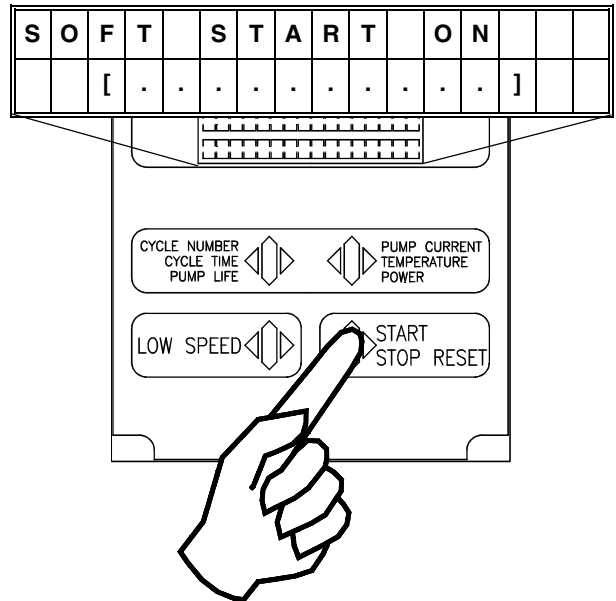

Where the sign minus (-) become a square (□) when the pump finish the ramp-up step. The active step is indicated by a flashing square (□).

- As the ten steps are fully covered, the pump will reach the Normal operation. If during the Soft Start mode the current drawn by the pump exceed 1.4 A the speed of the pump is decreased to maintain the maximum power allowable (1.4 A).

If within each step of the Soft Start mode the rotational speed of the pump do not reach the planned value within 15 minutes the display shows:

F	A	U	L	T	:										
O	V	E	R	T	I	M	E	:	S	X					

where **X** = the step number from 0 to 9 indicating the step number not passed. When this message is displayed the pump is stopped. Reset the controller by pressing twice the STOP push-button to start the pump.

- If the Soft Start mode has been deselected the display will change and shows:

P	U	M	P		I	S		S	T	A	R	T	I	N	G
1	2			X	X			K	R	P	M				

where:

1 2 = contrast inverted identifies the set point condition:

- **1** is displayed when relay R1 is de-energized and the related output is zero voltage.
- **2** is displayed when relay R2 is energized and the related output is 24 V.

XX KRPM = indicates the actual theoretical rotational speed of the pump as a function of the controller output frequency (range 9 to 75 KRPM).

- After START command, frequency output will be at the maximum level, then the frequency will decrease to a value proportional to the pump rotational speed (about 9 KRPM if the pump is completely stopped).

The pump will accelerate to its normal rotational speed and when this speed is reached, the display will be as follows, even if any previous display selection was made, and the normal condition has been reached.

N	O	R	M	A	L		O	P	E	R	A	T	I	O	N
				X	X			K	R	P	M				

where: **XX** =indicates the rotational speed (75 KRPM for high speed, or 50 KRPM for low speed).

During acceleration of the pump or during any operating condition, it is always possible to select the other parameters to be displayed (PUMP CURRENT or CYCLE NUMBER push-buttons).

If this is the case when the pump reaches the normal speed, the display reverts to the previous figure.

Operating the Pump

After the starting period, if the system has a vacuum leak or the pressure in the pump/chamber is high (from 1 mbar to atmosphere), the pump continues to operate indefinitely.

If the gas load at the turbopump inlet flange continues to stay high, the power drawn by the turbopump increases up to the maximum value. Then the Turbo-V pump is slowed down in proportion to the gas load at least until it reaches about 9 KRPM.

This will occur either in NORMAL operation or with the LOW SPEED selected.

As soon as the gas load decreases, the pump will automatically accelerate to reach normal operation.

The pump can be stopped at any rotational speed and can be restarted at any rotational speed from either the front panel buttons or the remote connections.

The controller automatically synchronizes the output to the rotational speed of the pump and then accelerates linearly up to the nominal speed or within steps if the Soft Start has been selected.

Low Speed Operation

This feature is provided for operating the pump at moderate high pressure with high gas throughput. To operate in this low speed mode, engage the LOW SPEED push-button once if the display shows:

R	E	A	D	Y		F	O	R		L	O	C	A	L	
S	O	F	T			S	T	A	R	T					

or:

P	U	M	P		R	E	A	D	Y	:		P	U	S	H	
					S	T	A	R	T		B	U	T	T	O	N

or:

N	O	R	M	A	L		O	P	E	R	A	T	I	O	N
				X	X			K	R	P	M				

Or twice if the display shows other parameters, either before starting the pump or after it is operating.
If LOW SPEED is selected before starting the pump, the display shows:

R	E	A	D	Y		F	O	R		L	O	C	A	L	
S	O	F	T		S	T	A	R	T					L	S

The pump reaches the Normal high speed, then decrease the speed to the low speed value and the display shows:

A	P	P	R	O	A	C	H	I	N	G		L	S		
			X	X		K	R	P	M				L	S	

If the Soft Start has been deselected the display shows:

P	U	M	P		R	E	A	D	Y	:		P	U	S	H
	S	T	A	R	T		B	U	T	T	O	N		L	S

where: **LS** = means low speed mode is selected.

After starting, a **LS** appears on the right bottom corner of the following displays:

S	O	F	T		S	T	A	R	T		O	N			
		[-	-	-	-	-	-	-	-	-	-	-	L	S

P	U	M	P		I	S		S	T	A	R	T	I	N	G
1	2			X	X		K	R	P	M				L	S

N	O	R	M	A	L		O	P	E	R	A	T	I	O	N
			X	X		K	R	P	M					L	S

With normal LOW SPEED operation, the pump will run at about 2/3 of its nominal speed and achieves a base pressure somewhat higher than the standard specifications. If the gas load becomes higher, the controller output frequency and voltage start to decrease automatically, and the Turbo-V pump is slowed down in proportion to the gas load until it reaches about 9 KRPM.

If the LOW SPEED mode is selected after normal operating condition is reached, the display shows:

A	P	P	R	O	A	C	H	I	N	G			L	S	
			X	X		K	R	P	M					L	S

while approaching the low speed value.
When the low speed mode is deselected, the pump starts to accelerate to its rotational speed.
The display shows:

N	O	R	M	A	L		O	P	E	R	A	T	I	O	N
			X	X		K	R	P	M						

Pump Shutdown

Press the front panel STOP pushbutton or remove the remote signal; the power from the turbopump will be removed and the pump will begin to slow down.

An emergency stop signal is provided via a remote contact. This signal is active in any of the three operation selections: FRONT, REMOTE, RS 232; when activated, the display will be as shown in the following figure.

			S	Y	S	T	E	M							
			O	V	E	R	R	I	D	E					

Power Failure

In the event of a power failure (momentary or long term), the Turbo-V controller will stop the turbopump and all the interconnected pumps/devices. The Turbo-V vent valve device, if used, will vent the turbopump only if the power failure is longer than the preset delay time. When power is restored, the Turbo-V controller automatically restarts the interconnected devices and the turbopump in the proper sequence.

The display shows:

P	U	M	P		I	S		S	T	A	R	T	I	N	G
1	2			X	X		K	R	P	M					

until normal operation achieved.

Remote Control Mode Operation

If remote signals are used to operate the controller, it must be programmed for remote operation (see paragraph "FRONT/REMOTE/232 Selection") and when ready to start, the display shows:

R	E	A	D	Y		F	O	R		R	E	M	O	T	E
S	O	F	T		S	T	A	R	T						

If the Soft Start has been deselected the display shows:

P	U	M	P		R	E	A	D	Y	:		U	S	E	
	R	E	M	O	T	E		S	T	A	R	T			

With or without Soft Start mode selected the START/STOP and LOW SPEED front panel pushbuttons are inoperative, while the CYCLE NUMBER and PUMP CURRENT pushbuttons are always active.

RS 232 Control Mode Operation

If the RS 232 option is installed and the controller has been programmed for RS 232 operation, the controller may be driven by a computer and when ready to operate, the display shows:

R	E	A	D	Y		F	O	R		R	S	2	3	2	
S	O	F	T		S	T	A	R	T						

If the Soft Start has been deselected the display shows:

P	U	M	P		R	E	A	D	Y	:		U	S	E	
	R	S	2	3	2		L	I	N	E					

With or without Soft Start mode selected the START/STOP, LOW SPEED functions are under computer control, while the CYCLE NUMBER and PUMP CURRENT front panel pushbuttons are always active.

ERROR MESSAGES

For a certain type of failure, the controller will self-diagnose the error and the following messages will be displayed.

NOTE

If the pump is not connected, the display will be as shown in the following figure.

C	H	E	C	K		C	O	N	N	E	C	T	I	O	N
			T	O		P	U	M	P						

Check connection between controller and pump, then press STOP push-button twice to start the pump.

NOTE

If the P1 input connector is not in position with the link or the external interlock connections are open, when the START pushbutton is pressed the display will be as shown in the following figure.

P	U	M	P		W	A	I	T	I	N	G				
I	N	T	E	R	L	O	C	K							

Disconnect connector P1 and check the link or the external interlock according to section II, then install the connector to start the pump.

NOTE

If within each step of the soft start mode the rotational speed of the pump do not reach the planned value within 15 minutes the display will be as shown in the following figure.

F	A	U	L	T	:										
O	V	E	R	T	I	M	E	:	S	X					

Verify that systems has no leaks than press STOP RESET pushbutton twice to start the pump.

NOTE

If the upper bearing/pump temperature exceeds 60 °C, the pump is shut off, and the display will be as shown in the following figure.

F	A	U	L	T	:					P	U	M	P		
						O	V	E	R	T	E	M	P	.	

The message will stay on until the temperature decreases below threshold value. Press the STOP RESET pushbutton twice to start the pump.

NOTE

If the controller transformer temperature exceeds 90°C, the pump is shut off, and the display will be as shown in the following figure.

F	A	U	L	T	:	C	O	N	T	R	O	L	L	E	R					
						O	V	E	R	T	E	M	P	E	R	A	T	U	R	E

The message will stay on until the temperature decreases below threshold value. Press the STOP RESET pushbutton twice to start the pump.

NOTE

If in normal operation (after the starting phase) the current drawn by the pump is higher than programmed (1.5 A), the pump and the inter-connected devices are switched off and the display will be as shown in the following figure.

F	A	U	L	T	:										
T	O	O		H	I	G	H		L	O	A	D			

Check that pump rotor is free to rotate then press the STOP RESET pushbutton twice to start the pump.

NOTE

After the starting phase if the output connection is shorted (output current higher than 2.2 A), the display will be as shown in the following figure.

F	A	U	L	T	:														
S	H	O	R	T		C	I	R	C	U	I	T							

Check connections and shortages between pump and controller, then press the STOP RESET pushbutton twice to start the pump.

NOTE

If the pump is stopped by an emergency stop signal provided via a remote contact, the display will be as shown in the following figure.

				S	Y	S	T	E	M										
				O	V	E	R	R	I	D	E								

Remove the controller power cable and check the emergency condition.

Then reconnect the power cable and press the START pushbutton to start the pump.

The following message is displayed if the fuse of the transformer secondary blows:

			C	O	N	T	R	O	L	L	E	R							
			F	A	I	L	U	R	E										

Since no operation can be carried out, contact VARIAN.

CONTROLLER TEST

a) Equipment required

- Digital voltmeter (DVM) true RMS.
- Dummy load: 3 x 48Ω, 50 W each or 3 x 78Ω, 50 W each.
- Potentiometer 50 KΩ, 1/4 W minimum.

b) Test set up

- Remove the power cable.
- Disconnect the Turbo-V controller.
- Remove the cover from the Turbo-V controller.
- Set potentiometer to 30 KΩ and connect it as directed in the following figure.
- Check the line voltage selector and connect the power cable to the appropriate socket.

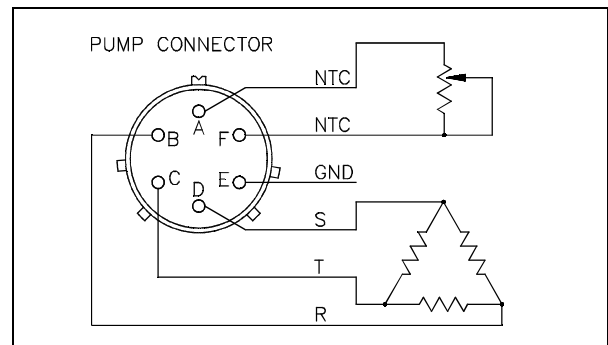

Dummy load connections

Power Supply Test

a) DC voltage test

Check the DC voltages referring to test points indicated in the following figure. The meter should read:

- + 5Vdc ±5%
- ±12 Vdc ±5%
- Ground reference = TP6.

On the controller front panel, push the START pushbutton and check:

- 54 Vdc ±10% between TP4(-) and TP6(+)
- 24 Vdc ±15% on the fan connector.

b) AC three-phase output voltage test

On the pump connector connect the DVM in turn between:

pins B and C, B and D, C and D.

The meter should read 44 Vac ±15%; a different value of 1 Vac is tolerable between phase and phase.

c) Front panel check

On the controller front panel, press the CURRENT pushbutton and check:

- Current 0.00 A
- Power 000 W
- Speed 75 KRPM
- Temperature 25 °C ±2 °C

On controller front panel, press STOP and remove the power cable.

Test with Dummy Load

- Connect the 48Ω or the 78Ω dummy loads to the pump connector pins B, C, D, as shown in the previous figure.
- Disconnect the potentiometer, set it to 10 KΩ, and then reconnect it.
- Connect the power cable.
- On the controller front panel push the START and CURRENT pushbuttons and check the front panel display as shown in the following table.

	During start-up without Soft Start mode		After start-up	
	With 48Ω dummy load	With 78Ω dummy load	With 48Ω dummy load	With 78Ω dummy load
Current ±10%	1.4 A	0.6 A	1.3 A	0.45 A
Power ±10%	80 W	40 W	70 W	24 W
Speed ±4 KRPM	34	75	9	75
Temperature ±2 °C	52 °C	52 °C	52 °C	52 °C

- Check the 3-phase ac output voltage. After start up it should be:
42 Vac with 78Ω dummy load and
42 Vac with 48Ω dummy load.

On the controller front panel, press the STOP pushbutton and remove the power cable.

Pump over-Temperature Test

- Disconnect the potentiometer, set it to 5KΩ, and then reconnect it.
- Disconnect the dummy loads.
- Connect the power cable.
- On the controller front panel push the START pushbutton.
The display should be as shown in Fig. 4-4 and by pressing the CURRENT pushbutton the temperature reading should be 71 °C ±2 °C. All the other values should be zero.
- Check the 3-phase ac output voltage. It should be zero.
- On the controller front panel, press STOP and remove the power cable.

Functional Test

Perform the functional test with the turbopump, taking care to check the ramp sequence and start up time.

ACCESSORIES AND SPARE PARTS

DESCRIPTION	PART NUMBER
J1 input mating connector	969-9853
P7 mating plug	969-9854
Mains cable (European plug, 3 m long)	03-660441-01
Mains cable (American plug, 120 V, 3 m long)	03-660441-02

OPTIONS

DESCRIPTION	PART NUMBER
RS 232 kit	969-9851
P2 output mating connector	969-9852
Controller to pump extension cable (5 m extension)	969-9950

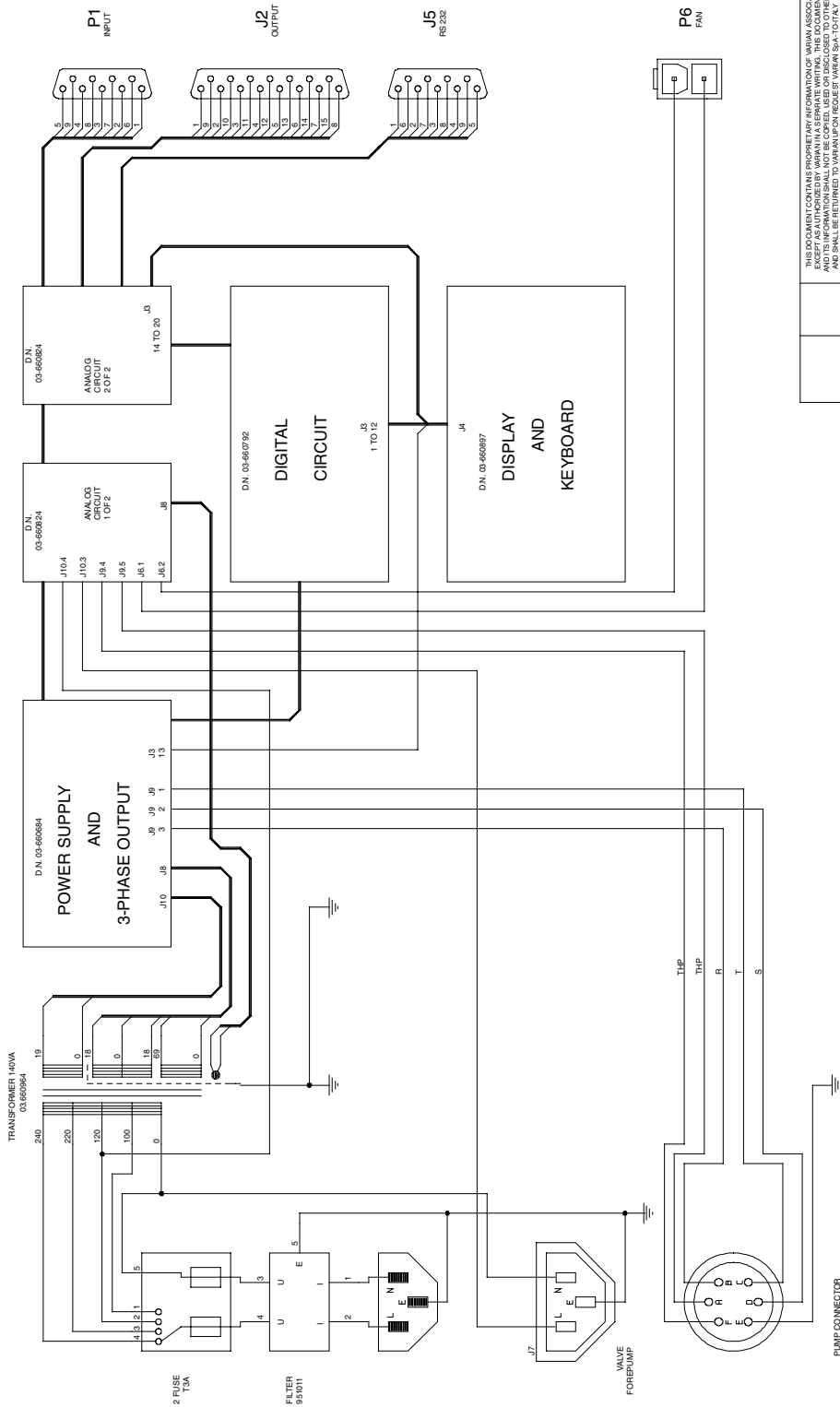

<p>THIS DOCUMENT CONTAINS PROPRIETARY INFORMATION OF MARIN ASSOCIATES EXCEPT AS AUTHORIZED BY WRITING IN A SEPARATE WRITING. THIS DOCUMENT AND ANY INFORMATION CONTAINED HEREIN IS UNCLASSIFIED AND SHALL BE RETURNED TO MARIN UPON RECEIPT OF MARIN SPA-TD/ITALY. (TOLERANCES UNLESS OTHERWISE SPECIFIED)</p>																										
<table border="1"> <tr> <th>DIMENSION</th> <th>>30</th> <th>>120</th> <th>>315</th> <th>>1000</th> <th>>2000</th> </tr> <tr> <td>ANGLE #</td> <td>30</td> <td>120</td> <td>315</td> <td>1000</td> <td>2000</td> </tr> </table>	DIMENSION	>30	>120	>315	>1000	>2000	ANGLE #	30	120	315	1000	2000	<table border="1"> <tr> <th>ANGLE #</th> <th>Ra (µm)</th> </tr> <tr> <td>30</td> <td>12.5</td> </tr> <tr> <td>120</td> <td>6.3</td> </tr> <tr> <td>315</td> <td>3.2</td> </tr> <tr> <td>1000</td> <td>1.6</td> </tr> <tr> <td>2000</td> <td>0.8</td> </tr> </table>	ANGLE #	Ra (µm)	30	12.5	120	6.3	315	3.2	1000	1.6	2000	0.8	CLASS H
DIMENSION	>30	>120	>315	>1000	>2000																					
ANGLE #	30	120	315	1000	2000																					
ANGLE #	Ra (µm)																									
30	12.5																									
120	6.3																									
315	3.2																									
1000	1.6																									
2000	0.8																									
<table border="1"> <tr> <th>MACHINING</th> <th>±0.2</th> <th>±0.3</th> <th>±0.5</th> <th>±0.8</th> <th>±1.2</th> <th>±2</th> </tr> <tr> <td>WELD CONSTR.</td> <td>±0.5</td> <td>±0.8</td> <td>±1</td> <td>±2</td> <td>±3</td> <td>±4</td> </tr> </table>	MACHINING	±0.2	±0.3	±0.5	±0.8	±1.2	±2	WELD CONSTR.	±0.5	±0.8	±1	±2	±3	±4	<table border="1"> <tr> <th>OTHER</th> <th>PARALLELISM</th> <th>PERPENDICULARITY</th> <th>CHAMFER</th> </tr> <tr> <td></td> <td>∥</td> <td>⊥</td> <td>∕</td> </tr> </table>	OTHER	PARALLELISM	PERPENDICULARITY	CHAMFER		∥	⊥	∕			
MACHINING	±0.2	±0.3	±0.5	±0.8	±1.2	±2																				
WELD CONSTR.	±0.5	±0.8	±1	±2	±3	±4																				
OTHER	PARALLELISM	PERPENDICULARITY	CHAMFER																							
	∥	⊥	∕																							
<table border="1"> <tr> <th>NUMBER</th> <th>POSITION</th> <th>DRAWN</th> <th>CHECKED</th> <th>DATE</th> <th>SCALE</th> </tr> <tr> <td>C13/94</td> <td></td> <td>C.M.</td> <td></td> <td>08/06/94</td> <td>/</td> </tr> </table>	NUMBER	POSITION	DRAWN	CHECKED	DATE	SCALE	C13/94		C.M.		08/06/94	/	<p>TV70 MAINS WIRING DIAGRAM</p>													
NUMBER	POSITION	DRAWN	CHECKED	DATE	SCALE																					
C13/94		C.M.		08/06/94	/																					
<table border="1"> <tr> <th>REVISION</th> <th>DATE</th> <th>SIZE</th> <th>DRAWING No.</th> </tr> <tr> <td>C</td> <td>06/94</td> <td>A3</td> <td>03.660683</td> </tr> </table>	REVISION	DATE	SIZE	DRAWING No.	C	06/94	A3	03.660683																		
REVISION	DATE	SIZE	DRAWING No.																							
C	06/94	A3	03.660683																							



Request for Return



1. A Return Authorization Number (RA#) **WILL NOT** be issued until this Request for Return is completely filled out, signed and returned to Varian Customer Service.
2. Return shipments shall be made in compliance with local and international **Shipping Regulations** (IATA, DOT, UN).
3. The customer is expected to take the following actions to ensure the **Safety** of workers at Varian: (a) Drain any oils or other liquids, (b) Purge or flush all gasses, (c) Wipe off any excess residues in or on the equipment, (d) Package the equipment to prevent shipping damage, (for Advance Exchanges please use packing material from replacement unit).
4. Make sure the shipping documents clearly show the RA# and then return the package to the Varian location nearest you.

North and South America

Varian Vacuum Technologies
 121 Hartwell Ave
 Lexington, MA 02421
 Phone : +1 781 8617200
 Fax: +1 781 8609252

Europe and Middle East

Varian SpA
 Via Flli Varian 54
 10040 Leini (TO) – ITALY
 Phone: +39 011 9979111
 Fax: +39 011 9979330

Asia and ROW

Varian Vacuum Technologies
 Local Office

CUSTOMER INFORMATION

Company name:	
Contact person: Name:	Tel:
Fax:	E-Mail:
Ship Method:	Shipping Collect #: P.O.#:
<u>Europe only:</u> VAT reg. Number:	<u>USA only:</u> <input type="checkbox"/> Taxable <input type="checkbox"/> Non-taxable
Customer Ship To:	Customer Bill To:
.....
.....

PRODUCT IDENTIFICATION

Product Description	Varian P/N	Varian S/N	Purchase Reference

TYPE OF RETURN (check appropriate box)

<input type="checkbox"/> Paid Exchange	<input type="checkbox"/> Paid Repair	<input type="checkbox"/> Warranty Exchange	<input type="checkbox"/> Warranty Repair	<input type="checkbox"/> Loaner Return
<input type="checkbox"/> Credit	<input type="checkbox"/> Shipping Error	<input type="checkbox"/> Evaluation Return	<input type="checkbox"/> Calibration	<input type="checkbox"/> Other

HEALTH and SAFETY CERTIFICATION

Varian Vacuum Technologies **CAN NOT ACCEPT** any equipment which contains **BIOLOGICAL HAZARDS** or **RADIOACTIVITY**. Call Varian Customer Service to discuss alternatives if this requirement presents a problem.

The equipment listed above (check one):

HAS NOT been exposed to any toxic or hazardous materials

OR

HAS been exposed to any toxic or hazardous materials. In case of this selection, check boxes for any materials that equipment was exposed to, check all categories that apply:

Toxic Corrosive Reactive Flammable Explosive Biological Radioactive

List all toxic or hazardous materials. Include product name, chemical name and chemical symbol or formula.

.....

Print Name: Customer Authorized Signature:

Print Title: Date:/...../.....

NOTE: If a product is received at Varian which is contaminated with a toxic or hazardous material that was not disclosed, **the customer will be held responsible** for all costs incurred to ensure the safe handling of the product, and **is liable** for any harm or injury to Varian employees as well as to any third party occurring as a result of exposure to toxic or hazardous materials present in the product.

Do not write below this line

Notification (RA)#: Customer ID#: Equipment #:

FAILURE REPORT

TURBO PUMPS and TURBOCONTROLLERS

<input type="checkbox"/> Does not start <input type="checkbox"/> Does not spin freely <input type="checkbox"/> Does not reach full speed <input type="checkbox"/> Mechanical Contact <input type="checkbox"/> Cooling defective	<input type="checkbox"/> Noise <input type="checkbox"/> Vibrations <input type="checkbox"/> Leak <input type="checkbox"/> Overtemperature	POSITION <input type="checkbox"/> Vertical <input type="checkbox"/> Horizontal <input type="checkbox"/> Upside-down <input type="checkbox"/> Other:	PARAMETERS Power: Rotational Speed: Current: Inlet Pressure: Temp 1: Foreline Pressure: Temp 2: Purge flow: <hr/> OPERATION TIME:
TURBOCONTROLLER ERROR MESSAGE:			

ION PUMPS/CONTROLLERS

<input type="checkbox"/> Bad feedthrough <input type="checkbox"/> Vacuum leak <input type="checkbox"/> Error code on display	<input type="checkbox"/> Poor vacuum <input type="checkbox"/> High voltage problem <input type="checkbox"/> Other
Customer application:	

VALVES/COMPONENTS

<input type="checkbox"/> Main seal leak <input type="checkbox"/> Solenoid failure <input type="checkbox"/> Damaged sealing area	<input type="checkbox"/> Bellows leak <input type="checkbox"/> Damaged flange <input type="checkbox"/> Other
Customer application:	

LEAK DETECTORS

<input type="checkbox"/> Cannot calibrate <input type="checkbox"/> Vacuum system unstable <input type="checkbox"/> Failed to start	<input type="checkbox"/> No zero/high background <input type="checkbox"/> Cannot reach test mode <input type="checkbox"/> Other
Customer application:	

INSTRUMENTS

<input type="checkbox"/> Gauge tube not working <input type="checkbox"/> Communication failure <input type="checkbox"/> Error code on display	<input type="checkbox"/> Display problem <input type="checkbox"/> Degas not working <input type="checkbox"/> Other
Customer application:	

PRIMARY PUMPS

<input type="checkbox"/> Pump doesn't start <input type="checkbox"/> Doesn't reach vacuum <input type="checkbox"/> Pump seized	<input type="checkbox"/> Noisy pump (describe) <input type="checkbox"/> Over temperature <input type="checkbox"/> Other
Customer application:	

DIFFUSION PUMPS

<input type="checkbox"/> Heater failure <input type="checkbox"/> Doesn't reach vacuum <input type="checkbox"/> Vacuum leak	<input type="checkbox"/> Electrical problem <input type="checkbox"/> Cooling coil damage <input type="checkbox"/> Other
Customer application:	

FAILURE DESCRIPTION

(Please describe in detail the nature of the malfunction to assist us in performing failure analysis):

NOTA: Su richiesta questo documento è disponibile anche in Tedesco, Italiano e Francese.
REMARQUE : Sur demande ce document est également disponible en allemand, italien et français.
HINWEIS: Auf Aufrage ist diese Unterlage auch auf Deutsch, Italienisch und Französisch erhältlich.

Sales and Service Offices

Argentina

Varian Argentina Ltd.

Sucursal Argentina
Av. Ricardo Balbin 2316
1428 Buenos Aires
Argentina
Tel: (54) 1 783 5306
Fax: (54) 1 786 5172

Australia

Varian Australia Pty Ltd.

679-701 Springvale Road
Mulgrave, Victoria ZZ 3170
Australia
Tel: (61) 395607133
Fax: (61) 395607950

Benelux

Varian Vacuum Technologies

Rijksstraatweg 269 H,
3956 CP Leersum
The Netherlands
Tel: (31) 343 469910
Fax: (31) 343 469961

Brazil

Varian Industria e Comercio Ltda.

Avenida Dr. Cardoso de Mello 1644
Vila Olimpia
Sao Paulo 04548 005
Brazil
Tel: (55) 11 3845 0444
Fax: (55) 11 3845 9350

Canada

Central coordination through:

Varian Vacuum Technologies
121 Hartwell Avenue
Lexington, MA 02421
USA
Tel: (781) 861 7200
Fax: (781) 860 5437
Toll Free: (800) 882 7426

China

Varian Technologies - Beijing

Room 1201, Jinyu Mansion
No. 129A, Xuanwumen Xidajie
Xicheng District
Beijing 1000031 P.R. China
Tel: (86) 10 6608 1530
Fax: (86) 10 6608 1534

France and Wallonie

Varian s.a.

7 avenue des Tropiques
Z.A. de Courtaboeuf – B.P. 12
Les Ulis cedex (Orsay) 91941
France
Tel: (33) 1 69 86 38 13
Fax: (33) 1 69 28 23 08

Germany and Austria

Varian Deutschland GmbH

Alsfelder Strasse 6
Postfach 11 14 35
64289 Darmstadt
Germany
Tel: (49) 6151 703 353
Fax: (49) 6151 703 302

India

Varian India PVT LTD

101-108, 1st Floor
1010 Competent House
7, Nangal Raya Business Centre
New Delhi 110 046
India
Tel: (91) 11 5548444
Fax: (91) 11 5548445

Italy

Varian Vacuum Technologies

Via F.lli Varian, 54
10040 Leini, (Torino)
Italy
Tel: (39) 011 997 9111
Fax: (39) 011 997 9350

Japan

Varian Vacuum Technologies

Sumitomo Shibaura Building, 8th Floor
4-16-36 Shibaura
Minato-ku, Tokyo 108
Japan
Tel: (81) 3 5232 1253
Fax: (81) 3 5232 1263

Korea

Varian Technologies Korea, Ltd.

Shinsa 2nd Bldg. 2F
966-5 Daechi-dong
Kangnam-gu, Seoul
Korea 135-280
Tel: (82) 2 3452 2452
Fax: (82) 2 3452 2451

Mexico

Varian S.A.

Concepcion Beistegui No 109
Col Del Valle
C.P. 03100
Mexico, D.F.
Tel: (52) 5 523 9465
Fax: (52) 5 523 9472

Taiwan

Varian Technologies Asia Ltd.

18F-13 No.79, Hsin Tai Wu Road
Sec. 1, Hsi Chih
Taipei Hsien
Taiwan, R.O.C.
Tel: (886) 2 2698 9555
Fax: (886) 2 2698 9678

UK and Ireland

Varian Ltd.

28 Manor Road
Walton-On-Thames
Surrey KT 12 2QF
England
Tel: (44) 1932 89 8000
Fax: (44) 1932 22 8769

United States

Varian Vacuum Technologies

121 Hartwell Avenue
Lexington, MA 02421
USA
Tel: (781) 861 7200
Fax: (781) 860 5437
Toll Free: (800) 882 7426

Other Countries

Varian Vacuum Technologies

Via F.lli Varian, 54
10040 Leini, (Torino)
Italy
Tel: (39) 011 997 9111
Fax: (39) 011 997 9350

Internet Users:

Customer Service & Technical Support:

vtt.customer.service@varianinc.com

Worldwide Web Site:

www.varianinc.com/vacuum

Order On-line:

www.evarian.com

Representatives in most countries



VARIAN