



# Agilent TriScroll 300, 600 Inverter

## Technical Specifications

		TriScroll 300 Inverter	TriScroll 600 Inverter
Pumping speed	60 Hz L/min, m <sup>3</sup> /h 50 Hz L/min, m <sup>3</sup> /h	250, 15 at full speed 250, 15 at full speed	500, 30 at full speed 500, 30 at full speed
Ultimate pressure, mbar (Torr)		1.3 x 10 <sup>-2</sup> (1 x 10 <sup>-2</sup> )	9.3 x 10 <sup>-3</sup> (7 x 10 <sup>-3</sup> )
Maximum inlet pressure, atm (psig)		1.0 (0)	1.0 (0)
Maximum outlet pressure, atm (psig)		1.1 (1.5)	1.1 (1.5)
Inlet connection		NW25	NW40
Exhaust connection		NW16	NW25
Gas ballast		¼-inch female NPT	¼-inch female NPT
Motor rating (1 phase), HP (kW)		0.67 (0.5)	0.67 (0.5)
Operating voltages (610 %)	1Ø 60 Hz 50 Hz 3Ø 60 Hz 50 Hz	100-115, 200-240 V 100-115, 200-240 V - -	200-240 V 200-240 V - -
Motor thermal protection		Automatic	Automatic
Operating speed	60 Hz (rpm) 50 Hz (rpm)	1800 at 62 Hz	1800 at 62 Hz
Cooling system		Air-cooled	Air-cooled
Ambient operating temperature, °C (°F)		5 to 40 (41 to 104)	5 to 40 (41 to 104)
Storage temperature, °C (°F)		-20 to 60 (-4 to 140)	-20 to 60 (-4 to 140)
Weight pump only, kg (lb)		26 (57)	31 (68)
Shipping weight, kg (lb)		34 (74)	39 (85)
Noise level (per ISO 11201), dB		Variable with frequency 55 - 68	Variable with frequency 55 - 68
Vibration level (per ISO 10816-1) mm/s		Variable with frequency	Variable with frequency



## Agilent TriScroll 300, 600 Inverter Pumping Curves

### TriScroll 300 Inverter

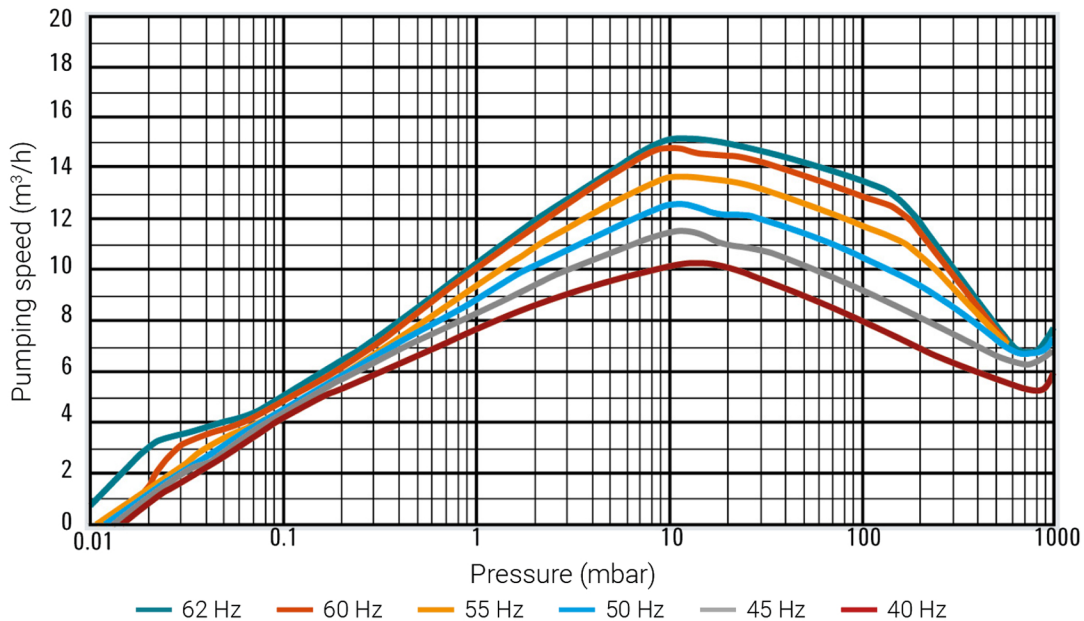

### TriScroll 600 Inverter

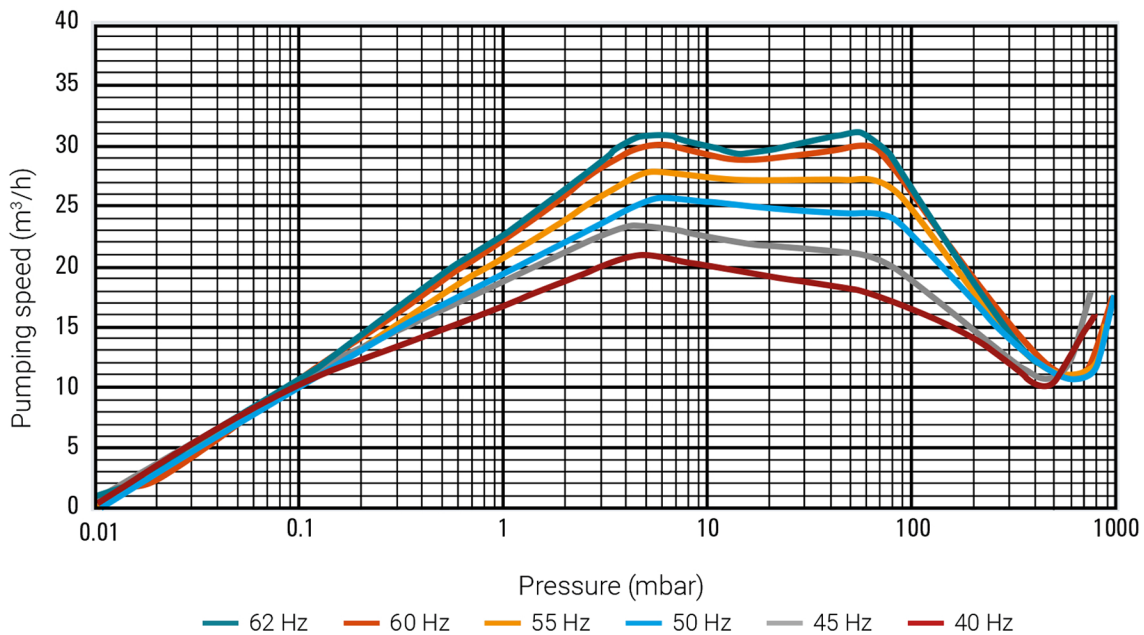



# PROVAC

## SALES

PHONE: 831-462-8900

FAX: 831-462-3536

WWW.PROVAC.COM

# Agilent TriScroll 300, 600 Inverter Dimensions

## TriScroll 300 Inverter

## TriScroll 600 Inverter

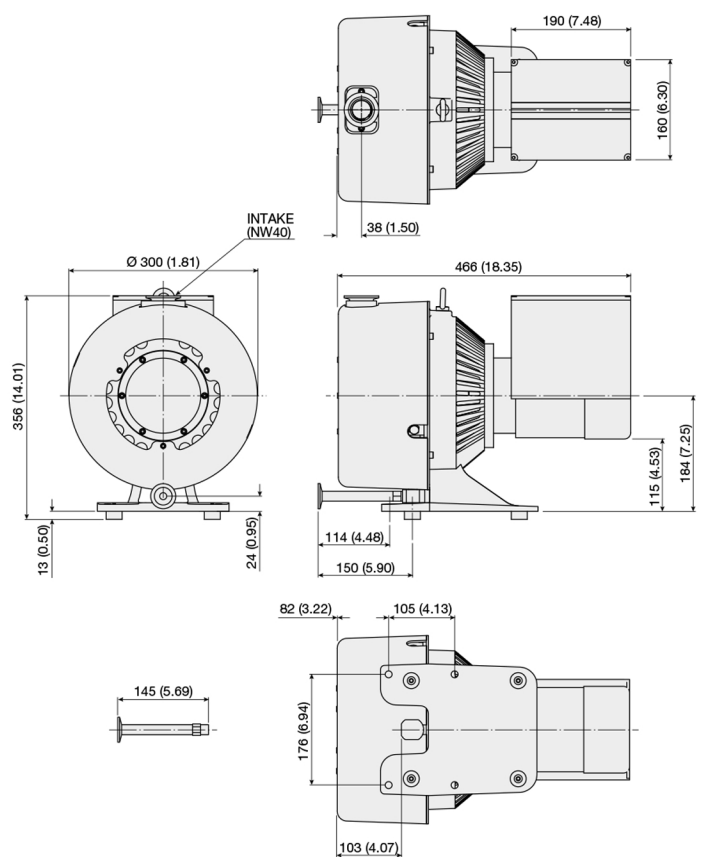
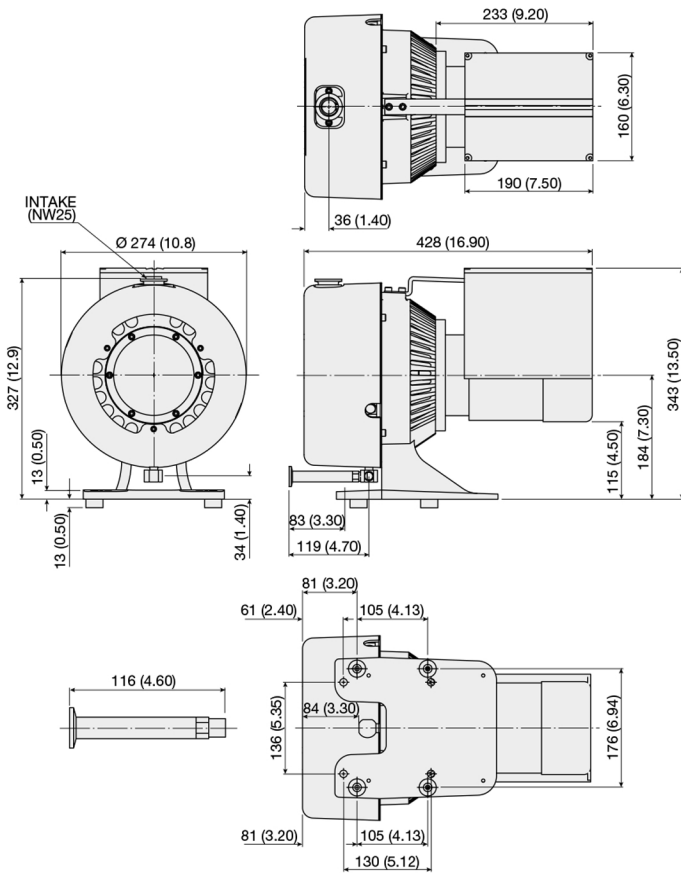

Dimensions: millimeters (inches)



**PROVAC**  
SALES

PHONE: 831-462-8900

FAX: 831-462-3536

WWW.PROVAC.COM

# Agilent TriScroll 300, 600 Inverter

## Features & Benefits

- anti-suckback valve and vent device
- universal voltage and frequency
- large pumping capacity
- clean, quiet, reliable
- compact design
- green technology
- built-in oil shield
- low power requirements
- lowest ultimate pressure
- enable selection of optimal pumping speed for any application by adjusting the rotational speed of the pump



## Applications

- scanning electron microscopes • laboratory • load locks • transfer chambers • beam lines • drying ovens • cryogenics • manufacturing
- glove box • backing pump • leak detection

