

87-900-817-01

February 1990

Instruction Manual

TURBO-V80 controller

Model 969-9412

Model 969-9512

()

()

()

TABLE OF CONTENTS

	Page
SAFETY SUMMARY	ii
Section	
I	DESCRIPTION
1.1	General 1
1.2	Turbo-V80 controller description 2
1.2.1	Turbo-V80 controller specifications 6
1.2.2	Controller outline 7
II	INSTALLATION
2.1	Turbo-V80 controller set up 9
2.1.1	Power interconnections 11
2.1.2	Logic interconnections 12
2.1.3	Turbo-V pump connection 15
III	OPERATING INSTRUCTIONS
3.1	General 17
3.2	Operating procedure 17
3.2.1	Start up 17
3.2.2	Operating 18
3.2.3	Overload 19
3.2.4	Shut down 19
3.2.5	Low speed operation 20
3.2.6	Power failure 20
IV	MAINTENANCE
4.1	General 21
V	SPARE PARTS LIST
5.1	Turbo-V80 Controller replacement parts 23

SAFETY SUMMARY

This instruction manual includes information required to enable qualified personnel to safely and reliably perform those functions for which the product was designed.

Should the product fail to operate, the operator

must call upon qualified maintenance personnel to troubleshoot and repair.

Throughout this manual you will find the words: **WARNING** **CAUTION** **NOTE** which have the following meaning

WARNING

Warnings are used when failure to observe instructions or precautions could result in injury or death to humans.

CAUTION

Cautions are used when failure to observe instructions could result in damage to equipment (Varian supplied and/or other associated equipment).

NOTE

Information to aid you in obtaining the best performance from your instrument.

1.1 GENERAL

The Turbo-V80 Controller is a solid state frequency converter with self-diagnostic and protection features.

It incorporates all the facilities required for the automatic operation of the Turbo-V80 pump series. Remote start/stop, pump status signals, forepump start/stop, interlock control (for pressure switch, water flow switch, etc.) capability, are provided via auxiliary connectors.

L.E.D. displays located on the front panel indicate the operating conditions of the Turbo-V pump.

Fig. 1.1 is a picture of the Turbo-V80 controller.

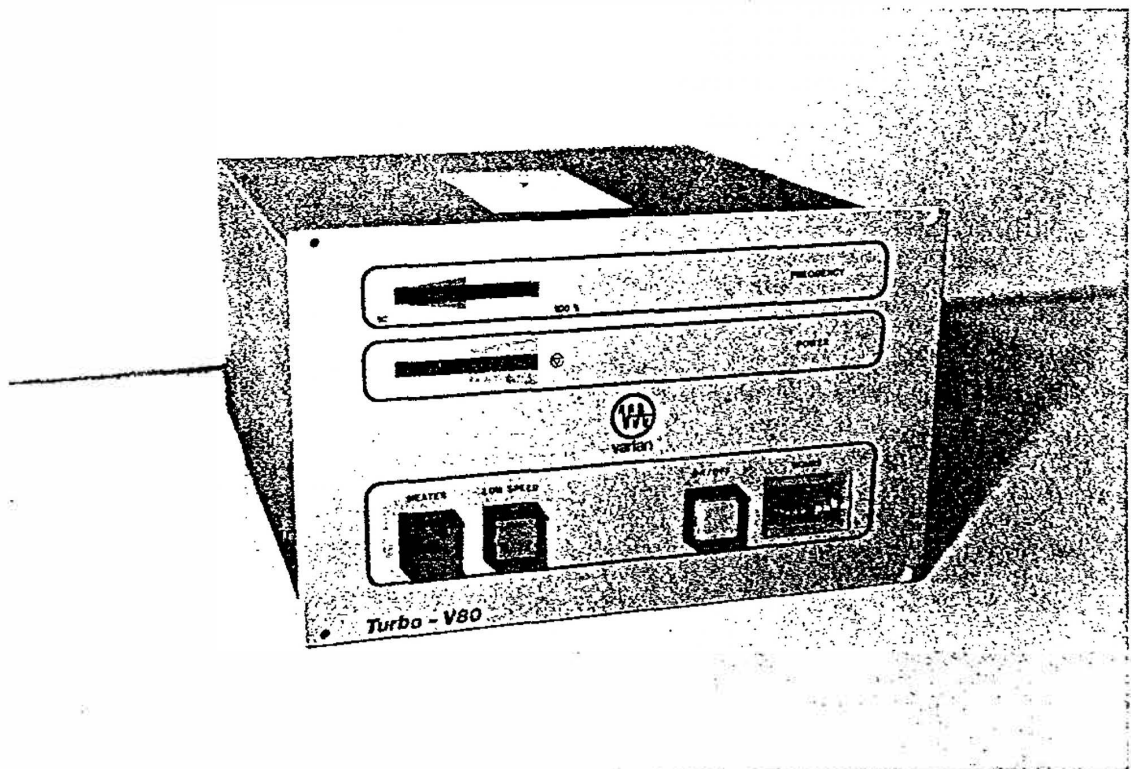

Fig. 1.1 - Turbo-V80 controller

SECTION I DESCRIPTION

1.2 TURBO-V80 CONTROLLER DESCRIPTION

The controller is available in two versions which differ in the factory-set input voltage:

- model 969-9412 (220 Vac, 50-60 Hz)
- model 969-9512 (120 Vac, 50-60 Hz)

The controller is a solid state frequency converter with control circuitry for automatic operation of the Turbo-V pump.

The frequency converter section consists mainly of four printed circuit boards, power board, interconnection board, control board, and display board; each is designed for easy replacement. The power board converts the single phase (50-60 Hz) AC mains supply into a DC voltage and then in a three phase, low voltage, medium frequency output which is required to power the Turbo-V pump. The interconnection board contains the line voltage selector, the power supply and the optoisolated interconnection circuits. The control board maintains a controlled acceleration of the pump by a gradual increase of frequency until the pump achieves its rated rotational speed. This frequency ramp ensures optimum acceleration with minimal losses and slip in the motor. The control board can correctly sequence for automatic operation the forepump, fan, vent device, and water cooling system components, and can accept inputs from external vacuum switches and the forepump contactor.

The display board drives the power and frequency bargraph.

The Turbo-V80 controller front panel controls are shown in Fig. 1.2.

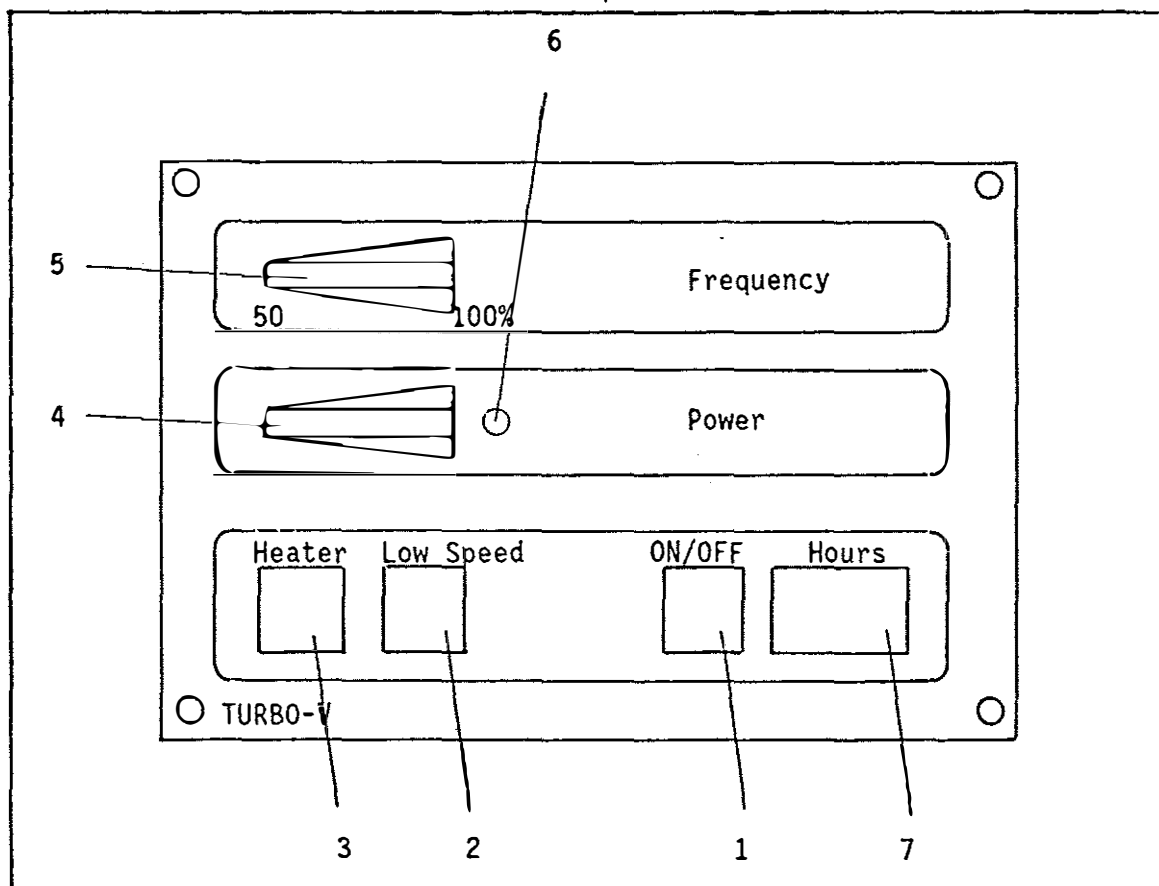
SECTION I
DESCRIPTION

- | | |
|-------------------|-----------------------|
| 1 - On / off | 5 - Frequency display |
| 2 - Low speed | 6 - Overload L.E.D. |
| 3 - Heater | 7 - Hour counter |
| 4 - Power display | |

Fig. 1.2 - Controller Front Panel

SECTION I
DESCRIPTION

1 On/Off

This switch starts the Turbo-V pump after a few seconds delay when engaged. Disengaging switch removes power from the pump and will stop it (regardless of the rotational speed).

The On/Off switch is also used to reset the pump/controller from a failure condition.

2 Low speed

When this switch is engaged the pump runs at about 70% of its normal speed.

3 Heater

When this switch is engaged an output voltage (same value as the mains) is present at the power interconnecting socket (J21) to power the heater band when the pump is in operation.

4 Power display

The display shows the power drawn by the pump.

It consists of twelve L.E.D.'s; the first L.E.D. will come on at about 24 W and the last L.E.D. is on when the power reaches about 135 W.

5 Frequency display

The display consists of 12 L.E.D's and indicates the output frequency of the controller. The first L.E.D. is on when the frequency output reaches 50% of the nominal value (500 Hz) and the last L.E.D. is barely visible at about 95% of the nominal frequency (950 Hz).

6 Overload L.E.D.

This L.E.D. indicates that the pump has been stopped due to:

- the pump has been operated at a pressure too high, or the power level exceeds 180 W for more than 20 seconds;
- the temperature of the pump exceeds 60°C
- the temperature of the transformer is above 90°C
- the temperature of the power PCB heat sink is above 60°C
- during the start-up time the power level exceeds 560 W during the first 45 seconds and 280 W during other 135 seconds.

SECTION I
DESCRIPTION

7 Hour counter

This meter indicates the Turbo-V pump operation time and is independent of the mains frequency.

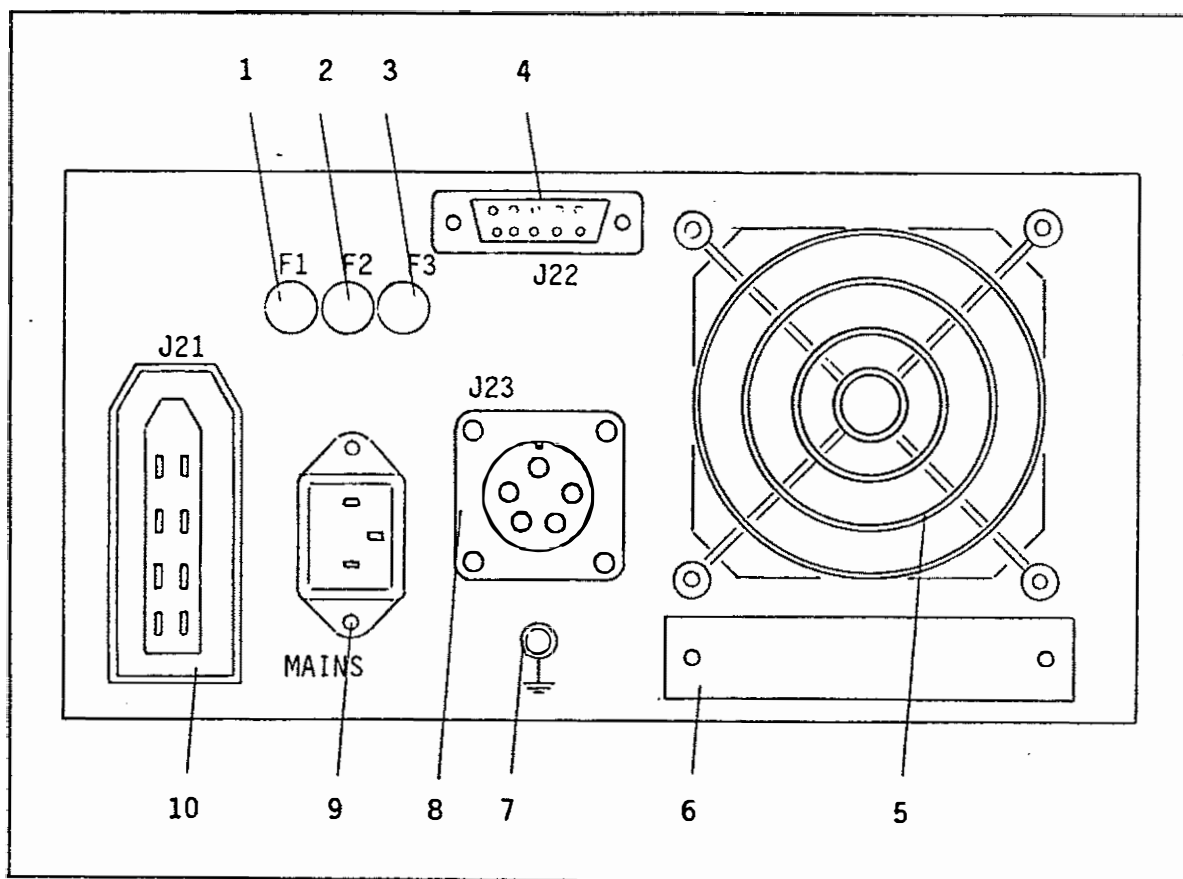

- | | |
|----------------------------------|-----------------------------------|
| 1 - F1 Mains fuse | 6 - Identification label |
| 2 - F2 Heater fuse | 7 - Ground connection |
| 3 - F3 Pump fuse | 8 - Turbo-V pump socket |
| 4 - Logic interconnection socket | 9 - Line socket |
| 5 - Cooling fan | 10 - Power interconnection socket |

Fig. 1.3 - Controller rear panel

SECTION I
DESCRIPTION

1.2.1 TURBO-V80 CONTROLLER SPECIFICATIONS

Input voltage	100-120-220-240 Vac \pm 10% 1 phase	
frequency	47 to 63 Hz	
power	680 VA maximum	
Output voltage	54 Vac \pm 3% 3 phases	
frequency	1000 Hz \pm 2%	
power	560 W maximum	
Operating temperature	0 to 40 °C	
Storage temperature	-20 to +70 °C	
Fuse F1 (mains)	T 8 A (slow blow) for 100-120 Vac T 5 A (slow blow) for 220-240 Vac	
F2 (heater)	T 5 A (slow blow) disregarding the mains	
F3 (pump)	T 16 A (slow blow)	
Optoisolator input (remote start, remote low speed)	minimum ON	4 Vdc, 1.6 mA
	maximum	16 Vdc, 9 mA
	reverse voltage	3 Vdc
	insulation voltage	150 V
Optoisolator output (normal/overload)	minimum testify	saturation output
	current 1.6 mA	(VCE max 0.6 Vdc)
	breakdown voltage	BVCEO 70 Vdc
Auxiliary output connectors	power socket (ref. sect. II) logic socket (ref. sect. II)	
Interconnecting cables	mains cable (3 wire, 3 meters long) pump cable (5 wire, 5 meters long)	
Weight	6.1 Kg (13.5 lbs)	

SECTION I
DESCRIPTION

1.2.2 CONTROLLER OUTLINE

The outline dimensions for the Turbo-V controller are shown in Fig. 1.4.

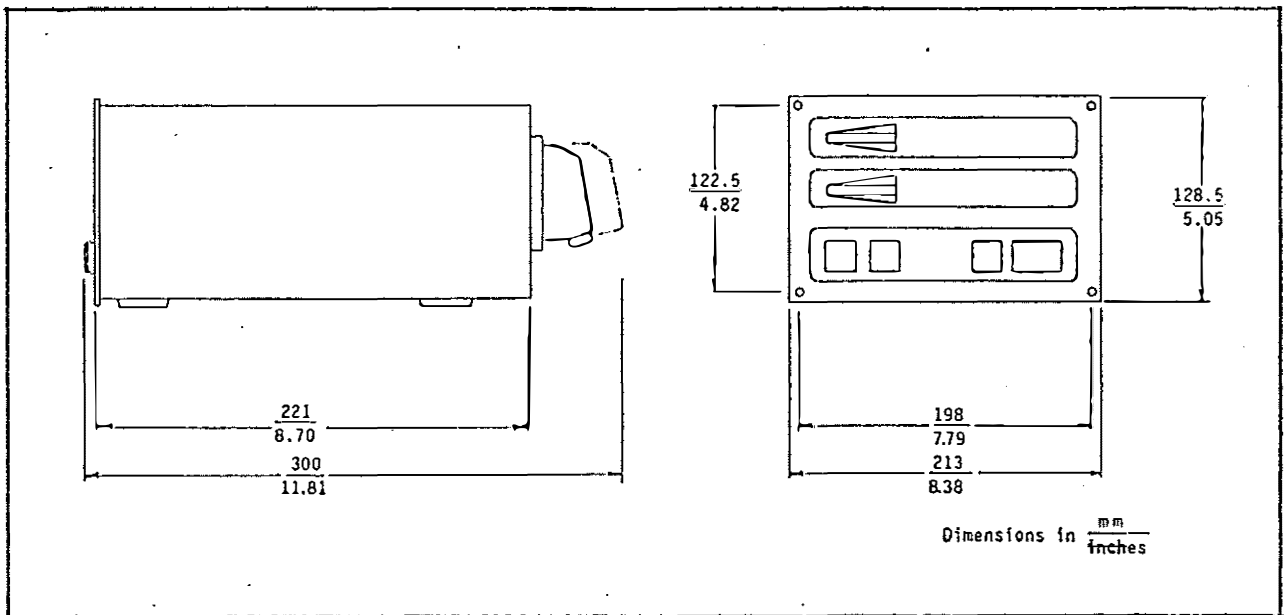

Fig. 1.4 - Controller Outline

This page is intentionally
left blank

SECTION II
INSTALLATION

2.1 TURBO-V80 CONTROLLER SET UP

Inspect the controller for any shipping damage.

The Turbo-V80 controller model 969-9412 is factory set for 220 Vac operation and the model 969-9512 is factory set for 120 Vac operation.

Both controller models are set up to use with a grease lubricated pump 969-9014, 969-9015, 969-9016.

NOTE

To operate the Turbo-V80 model 969-9011, 969-9012, 969-9013 (oil pumps), remove the jumper on control PCB as directed at point b) below.

This jumper determine the parameters that will be set up for the associated pumps.

WARNING

High voltage developed in the controller can cause severe injury or death. Before servicing the unit, turn off front panel switch and disconnect input power cable.

NOTE

The Turbo-V controller can be used as a bench unit or as a rack module, but must be positioned so that free air can flow through the holes.

NOTE

The Turbo-V controller is equipped with a 3 wire power cord and plug (internationally approved) for user's safety. Use this power cord and plug in conjunction with a properly grounded power socket to avoid electrical shock.

SECTION II INSTALLATION

a) Mains change over

If a change in line voltage operation is desired, proceed as follows:

- disconnect the power cord and remove the Turbo-V controller cover
- check line voltage selector setting on main PCB
- remove line voltage selector cord and select operating voltage 110/120/220/240 Vac than insert board into slot
- check for correct mains Fuse F1 value (see par. 1.2.1)
- install cover and connect the power cord.

b) Grease/oil pump operation change over

- disconnect the power cord and remove the Turbo-V controller cover
- on control PCB, right back side (fig. 4.1), just lift the jumper up and out of it socket
- install cover and connect the power cord.

SECTION II
INSTALLATION

2.1.1 POWER INTERCONNECTIONS

The controller is provided with a power connector plug P21. Ensure that the main circuit breaker is off, then remove the plug and wire the pins (maximum wire size 18 AWG) as indicated below to obtain the desired capability (Fig. 2.1).

Pin 1a Ground

Pin 1b-3a Output of 120 Vac (independent of line voltage)
3b-3a - 0.4 A total for vent device forepump relay coil
2b-2a and Turbo-V fan.

Voltage is present after ON/OFF push button is pressed (with the proper links on P22) and will remain present until an overload or power is removed from the turbopump.

Pin 4b - 4a Output mains voltage 3 A max for heater band.
Voltage is present only when the turbopump is running and the HEATER push button is pressed.

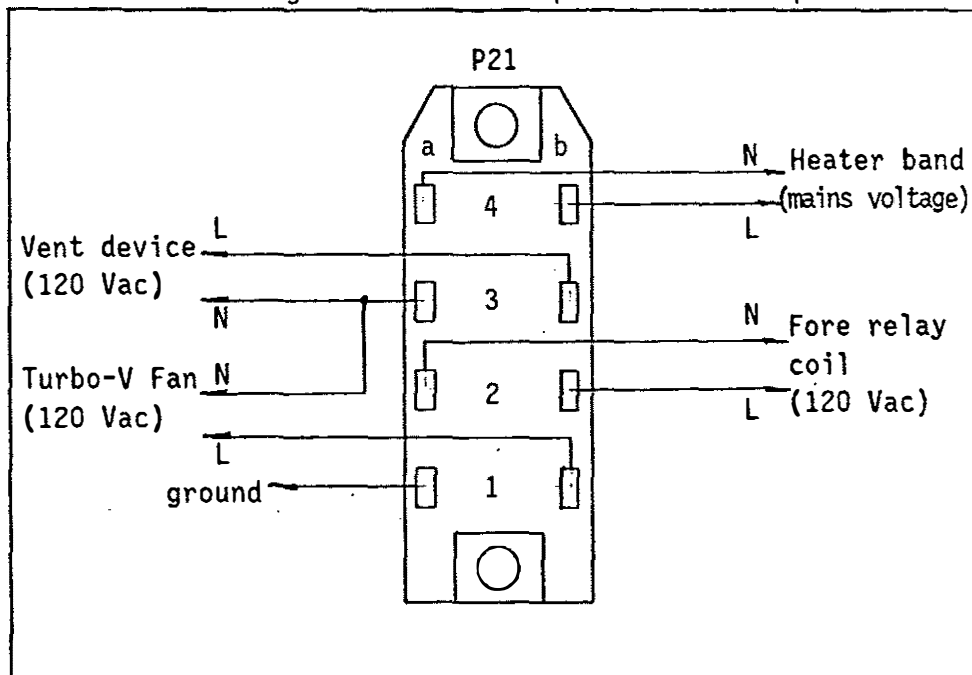

Fig. 2.1 - Power socket output signals

SECTION II
INSTALLATION

2.1.2 LOGIC INTERCONNECTIONS

All logic controls inputs and outputs are accessible at logic connector J22. Ensure that the mains circuit breaker is off, then remove the provided mating connector P22 and make the connections with 26 AWG (or smaller) wire to the pins as indicated below to obtain the desired capability (see Fig. 2.2).

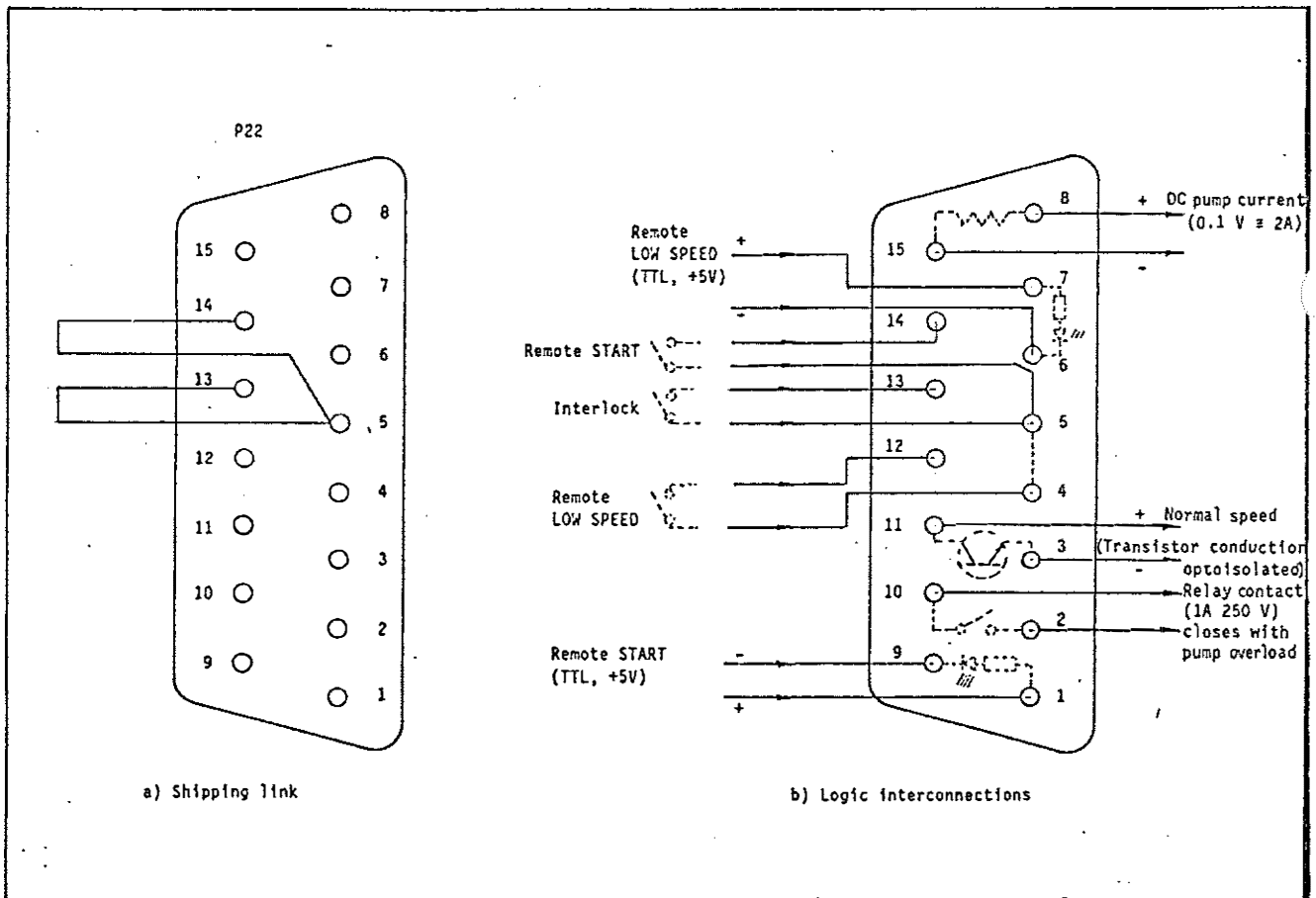

Fig. 2.2 - Logic Connector Configuration

SECTION II
INSTALLATION

a) Input to the Turbo-V Controller

NOTE

Even if the remote Start is used, the ON/OFF switch must be pressed (ON).

Pin 1-9 Remote START optically isolated from the internal circuit, requires a permanent logic level of 5 Vdc (1 mA minimum) and is TTL compatible.

When this signal is present the turbopump starts and when the signal is removed the turbopump is stopped.

Pin 14-5 Remote START requires a permanent closed contact.

With the contact closed the turbopump starts, and stops when the contact opens.

NOTE

Pin 14-5 must be shorted to allow the Turbo-V pump to start if a remote contact is not used.

Pin 7-6 Remote LOW-SPEED optically isolated from the internal circuit, require a permanent logic level of 5 Vdc (1 mA minimum) and is TTL compatible.

When this signal is present the turbopump runs at low speed and when it is not present the turbopump is at high speed.

Pin 12-4 Remote low speed requires a permanent closed contact.

With the contact closed the turbopump runs at low speed and runs up at high speed when the contact opens.

NOTE

With the Low Speed front panel switch to ON the remote switch is inoperative and viceversa.

SECTION II
INSTALLATION

Pin 13-5 INTERLOCK (e.g. vacuum pressure switch, water flow switch, feedback from the forepump relay) requires a permanent closed contact. This signal can be used to delay the starting of the turbopump and when the contact is open the turbopump stops.

NOTE

Pin 13-5 must be shorted to allow the Turbo-V pump to start if a vacuum pressure switch or an external contact is not connected.

b) Output from the Turbo-V Controller

Pin 11-3 Remote NORMAL speed indication optically isolated output (Pin 11 positive, pin 3 negative). When the pump is not in normal speed (either High or Low speed) the controller output is an open collector transistor.

Pin 15-8 Analog output of DC pump current draw
0.1 V proportional to 2 A.

Pin 2-10 Fault contact
This contact (which carries 1 A, 250 V max) is open when the turbopump is running and closes when the pump is turned off for a pump/controller malfunction condition only.

A typical Turbo-V controller interconnection diagram is shown in Fig. 2.3.

2.1.3 TURBO-V PUMP CONNECTION

WARNING

Before connecting the Turbo-V pump to the controller, ensure correct grounding between pump and controller.

A five-meter long cable is provided to connect the controller to the pump. The output connector is shown in Fig. 2.4 and has the following pin configuration:

Pin A-E Input from pump thermistor

Pin B-C-D 54 Vac, 3 phase output to pump motor stator

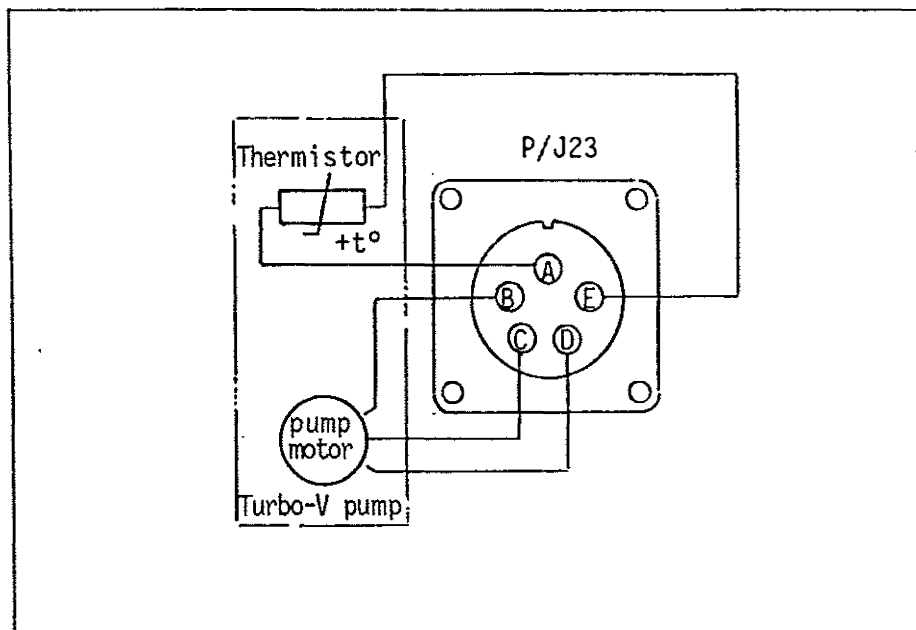

Fig. 2.4 - Turbo-V Pump Connector

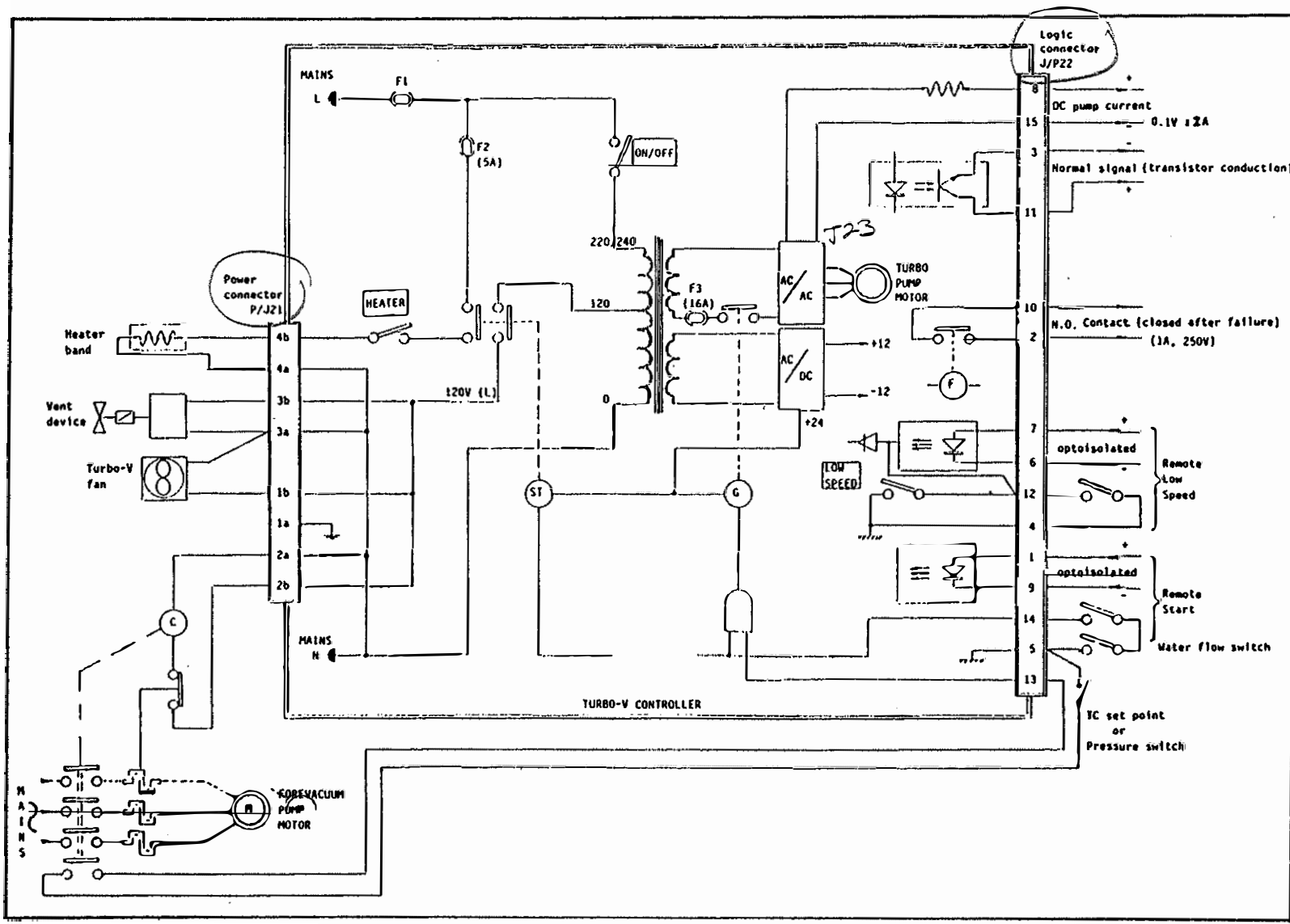

Fig. 2.3 - Typical Turbo-V Controller Interconnecting diagram

SECTION III
OPERATING INSTRUCTIONS

3.1 GENERAL

Make all vacuum manifold and electrical connections and refer to Turbo-V Instruction Manual prior to operating the Turbo-V controller.

—WARNING—

To avoid injury to personnel and damage to the equipment, if the pump is supported by its rubber feet, make sure it is steady or attach the pump to the bench using the threaded holes where the rubber feet are installed.

—NOTE—

The forepump and the Turbo-V pump can be switched on at the same time if a pressure less than 1 mbar is obtained in the chamber within the Turbo-V pump start-up time.
If the vacuum chamber is larger, it must be roughed down before starting the Turbo-V pump.

—NOTE—

The logic plug must be left in position including the shipping links if no external interconnections are made for the controller to operate.

3.2 OPERATING PROCEDURE

To operate the Turbo-V pump and controller either remotely or from the front panel, proceed as follows:

3.2.1 START UP

- a) Plug the controller power cable into a suitable power source.

SECTION III OPERATING INSTRUCTIONS

- b) If the forepump and vent device are not operated by the controller, close the vent valve and switch on the forepump.

~~NOTE~~

Even if the remote Start is used, the ON/OFF switch must be pressed (ON).

- c) Press the ON/OFF button or use the remote START signal: the FREQUENCY L.E.D.'s and the POWER L.E.D.'s will light, and the power output will be at the maximum level. The frequency display will go to the minimum values (about 60% of nominal frequency if the pump is completely stopped) or to a higher value proportional to the rotational speed of the pump. The pump will accelerate to its rated rotational speed and the frequency display lights up to 100%. When this speed is reached about half or the power L.E.D.'s will remain lighted to indicate that the normal condition has been reached. If the system has a vacuum leak and/or the pump draws too much power but below the overload threshold, the power L.E.D.'s will continue to stay fully or partially on.

3.2.2 OPERATING

- a) When the gas load at the turbopump inlet flange increases, the power drawn by the turbopump increases to maintain the rotational speed. This will occur either in normal operation or with the Low Speed switch engaged. In normal speed, when the gas load becomes higher, the control frequency starts to decrease automatically. The Turbo-V pump is slowed down proportionally to the gas load at least until it reaches about 70% of the nominal speed. Subsequently the power drawn by the turbopump increases to the overload threshold. At this point the turbopump and the interconnected accessories are stopped.

SECTION III
OPERATING INSTRUCTIONS

- b) The pump can be stopped at any rotational speed and can be restarted at any rotational speed from either the front panel buttons or the remote connections. The controller automatically synchronizes the output to the rotational speed of the pump and then accelerates up to the nominal speed.

3.2.3 OVERLOAD

- a) For the following conditions the OVERLOAD L.E.D. will light shutting down the output power to the turbopump, the forepump and the fan (if connected):
- 1) If a short circuit occurs on the pump motor stator
 - 2) If the pump is overheated (above 60°C)
 - 3) If the power drawn by the pump exceeds 180 W for more than 20 seconds
 - 4) If the controller (transformer, power device) is overheated
 - 5) If during the start-up time the power level exceeds 560 W during the first 45 seconds and 280 W during other 135 seconds.
- b) Once the fault that caused an overload condition is corrected, press the ON/OFF button twice to restart.

3.2.4 SHUT DOWN

- a) Press the ON/OFF button or remove the remote signal; power is removed and the pump will begin to slow down. If the forepump is interfaced to the controller it will automatically be switched off. If the recommended Turbo-V vent device model 969-9831 is used, after a time delay the Turbo-V pump will be vented.

CAUTION

When the Turbo-V pump is shut down for any reason the pump must be vented from the high vacuum side with dry and inert gas to prevent back-streaming from the forepump line into the Turbo-V pump.

SECTION III OPERATING INSTRUCTIONS

- b) The Turbo-V pump can be shut down at any rotational speed by pressing the ON/OFF button.

NOTE

It is recommended to operate the vent device and the forepump automatically by the controller in order to ensure correct sequences.

- c) Turn off the cooling water supply to avoid vapor condensation in the pump.

3.2.5 LOW SPEED OPERATION

When a low base pressure or maximum pumping speed are not required, this mode of operations reduce the bearing wear with subsequent increase of pump life.

NOTE

With the Low Speed front panel switch to ON the remote switch is inoperative and viceversa.

This feature becomes active 3 minutes after start. To operate in this low speed mode, engage the Low Speed switch either before starting the pump or after it is operating. The Turbo-V pump will run at about 3/4 of its normal speed and achieve a base pressure somewhat higher than the standard specifications.

About half of the frequency L.E.D.'s will remain lighted to indicate the low speed operation. If the gas load becomes higher, the power drawn by the turbopump increases to the overload threshold. At this point the turbopump and the interconnected accessories are stopped.

3.2.6 POWER FAILURE

In the event of a power failure (momentary or long period) the Turbo-V controller will stop the turbopump and all the interconnected pumps/device. The Turbo-V vent device if used will vent the turbopump only if the power failure is longer than preset delay time. When power is restored, the Turbo-V controller automatically restarts the interconnected devices and turbopump in the proper sequence.

4.1 GENERAL

Replacement controllers are available on advance exchange basis through Varian Service.

WARNING

High voltage in the controller can cause severe injury or death. Service must be performed by authorized personnel only.

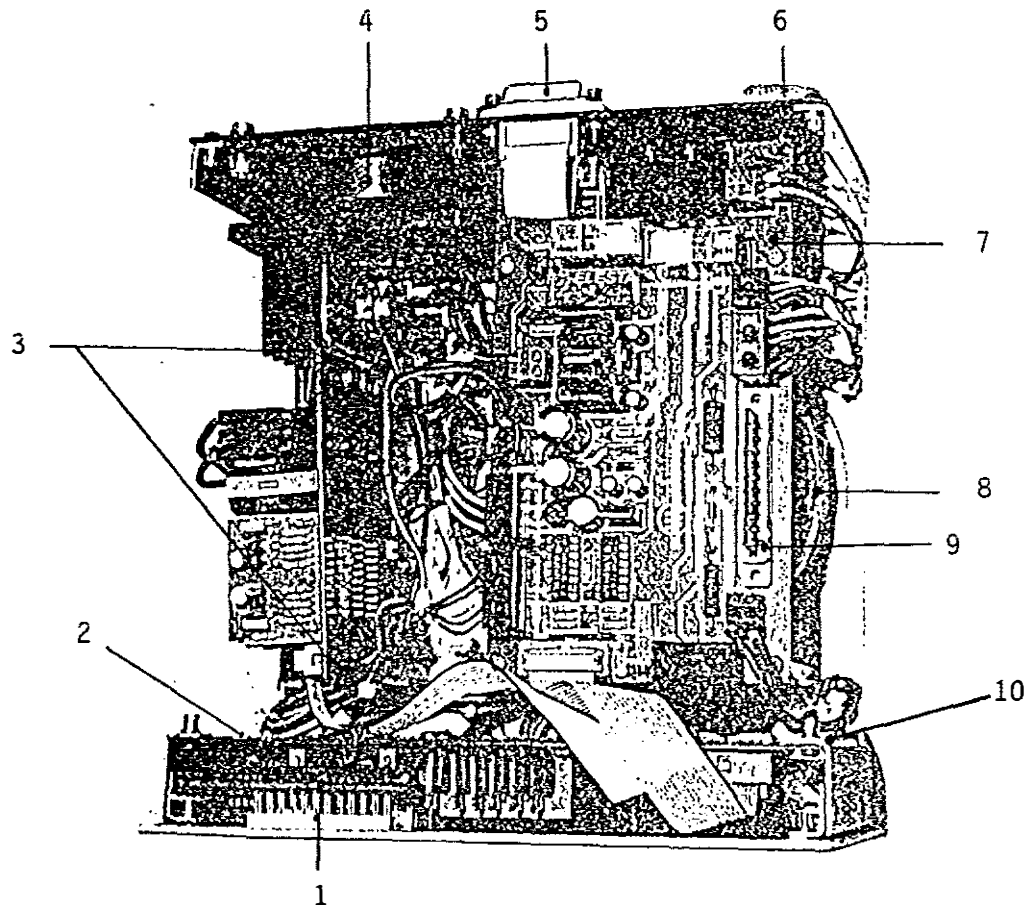

- | | |
|------------------------|--------------------------|
| 1) L.E.D. displays PCB | 6) Power socket |
| 2) Control PCB | 7) Interconnection PCB |
| 3) Power PCB | 8) Power transformer |
| 4) Fan | 9) Voltage selector card |
| 5) Logic socket | 10) Oil/Grease jumper |

Fig. 4.1 - Controller Components location (top view)

This page is intentionally
left blank

SECTION V
SPARE PARTS LIST

5.1 TURBO-V80 CONTROLLER REPLACEMENT PARTS

<u>Description</u>	<u>Part Number</u>
Power PCB assy	03-660437
Control PCB assy	03-660438-01
Interconnection PCB assy (set to 220 V)	03-660439-02
Interconnection PCB assy (set to 120 V)	03-660439-01
Display PCB assy	03-660440
Push-button ON/OFF	03-660435-01
Push-button LOW SPEED	03-660435-02
Push-button HEATER	03-660435-03
Lamp 28 V (Low speed, On/Off) <i>TYPE 334</i>	03-660435-55
Lamp 60 V (Heater)	03-660435-56
Hour counter	03-660405-52
Fan 24 Vdc	03-660405-51
Panel connector J23 pump	03-660405-53
Mating connector P23	03-660432-51
Panel connector J22 logic (with flat cable)	03-660433-03
Mating connector P22	03-660421
Panel connector J21 power	03-660436-01
Mating connector P21	03-660436-02
Interconnecting cable controller/pump	03-660432

