

Instruction Manual (B)

STP Series Turbomolecular Pumps STP-XA2703/XA3203 Series Pump Specific Information

<i>Model name</i>	<i>Voltage</i>
<i>STP-XA2703/XA3203 series</i>	<i>200 - 240 Va.c.</i>



STP pump consists of the three-volumed Instruction Manuals.

Instruction Manual (A):	STP pump generic Instruction Manual Supplied with STP pump
➔ Instruction Manual (B): (This Instruction Manual)	STP pump specific information Supplied with STP pump
Instruction Manual (C):	STP control unit Instruction Manual Supplied with STP control unit



This page intentionally blank

The description of this product consists of the three-volumed Instruction Manuals. Read through each Instruction Manual before operation.

The separate volume contents of each description are as follows:

Instruction Manual (A)

STP pump generic Instruction Manual:

- Introduction
- Installation of the STP pump
- Installation of the STP control unit
- Operation
- Safety functions
- Maintenance and inspection
- Storage and disposal
- Service, Spares and accessories

Instruction Manual (B)

STP Pump specific information:

- Technical data
- How to Secure the STP pump
- Temperature Management System (TMS)

Instruction Manual (C)

STP control unit Instruction Manual:

- Introduction
- Technical data
- Installation
- Operation
- Serial communication protocol
- STP-Link (except for SCU-750)
- Maintenance
- Storage, transportation and disposal
- Service, spares, and accessories

Keep the manuals in an easily accessible location.



EC DECLARATION OF CONFORMITY

Manufacture: Edwards Japan Limited
1078-1, Yoshihashi, Yachiyo-shi, Chiba 276-8523, Japan
EU Representative: Edwards Limited
York Road, Burgess Hill, West Sussex RH15 9TT, UK

declare under our sole responsibility that the product

Product Name: Turbomolecular pump
Model Number: STP-XA2703 / XA3203 series
Accessories Covered: TMS Unit

to which this declaration relates is in conformity with the following standards:

EN 1012-2: 1996
EN 61010-1: 2001
EN 61326: 1998 (EMI: Class A, EMS: Annex A)

and with the following provisions of EC directive

Machinery Directive (98/37/EC)
Low Voltage Directive (2006/95/EC)
EMC Directive (2004/108/EC)

EMC test report is certified by

Certificate number: E8 04 09 47212 004
Certification Body: TÜV PRODUCT SERVICE GMBH
Zertifizierstelle Ridlerstrasse 65, D-80339 München, Germany

Manufacture:

Yachiyo 10th Aug. '07
Place and date

Masaharu Miki
Mr. Masaharu Miki
Director, Technology
Edwards Japan Limited

EU representative:

Crawley, 17th August 2007
Place and date

Stephen E. Ormrod
Dr. Stephen E Ormrod
Technical Director
Edwards Limited



STP-XA2703/XA3203 Series Turbomolecular Pump

CONTENTS

Section	Title	Page
1	TECHNICAL DATA	1
1.1	Applicable pump specifications	1
1.1.1	STP pump specifications	2
1.1.2	Condition for the water-cooling unit	3
1.2	External appearance of the STP pump	4
1.3	Label affixing positions	6
1.4	Accessories	7
2	HOW TO SECURE THE STP PUMP	9
3	TEMPERATURE MANAGEMENT SYSTEM (TMS)	15
3.1	Configuration of the STP pump with the TMS	15
3.2	TMS connection cable	16
3.3	TMS heater	17
3.4	TMS valve	17
3.5	TMS sensor cable	17
3.6	Installation of the TMS unit	18
3.6.1	Connecting the TMS connection cable to the STP control unit	18
3.6.2	Connecting the pump and cables	18
3.6.3	Connecting TMS connection cable to STP pump	18
3.7	Condition for the TMS unit	19
3.8	Accessories	19

ILLUSTRATIONS

Figure	Title	Page
1	STP-XA2703 series: VG250/ISO250F/ICF305 (DN250CF)	4
2	STP-XA3203 series: VG300/ISO320F/ICF356 (DN320CF)	5
3	Label affixing positions for the STP pump	6
4	Methods of securing the STP pump	10
5	Shape of reduced diameter shank bolts	11
6	Configuration of the TMS	15
7	External view of TMS connection cable	16
8	TMS sensor cable	17

TABLES

Table	Title	Page
1	Tightening torque of bolt	9
2	Maximum torque predicted and recommended securing bolt for inlet port flange (STP-XA2703 series)	12
3	Maximum torque predicted and recommended securing bolt for inlet port flange (STP-XA3203 series)	13



STP-XA2703/XA3203 Series Turbomolecular Pump

1 TECHNICAL DATA

1.1 Applicable pump specifications

Model Name	Specification	Applicable Control unit ^{*1}
STP-XA2703/XA3203 series	Extreme Advanced throughput type	SCU-1500/SCU-1400

^{*1} Applicable control unit: There are different performance specifications between SCU-1500 and SCU-1400. Refer to Section 1.1.1, "STP pump specifications" for the differences.

Naming convention:

- "C" following a pump model name indicates a corrosion resistant^{*2} type (e.g. STP-XA2703C).
- "CV" indicates an enhanced corrosion resistant type with TMS^{*3} (e.g. STP-XA3203CV).

^{*2} Corrosion resistant: STP pump with anti-corrosive treatment.

^{*3} Temperature Management System: TMS maintains the temperature of the turbomolecular pump by monitoring the temperature with the thermistor in the base of the turbomolecular pump, and performing the TMS valve and base heater ON/OFF control.





STP-XA2703/XA3203 Series Turbomolecular Pump

1.1.1 STP pump specifications

The values shown below are typical. They are not guaranteed.

Item		XA2703 series	XA3203 series
Flange size	Inlet port flange	VG250/ISO250F/ ICF305 (DN250CF)	VG300/ISO320F/ ICF356 (DN320CF)
	Outlet port flange	KF40	KF40
Pumping speed	N ₂ L/s	2650	3200
	H ₂ L/s	2050	2300
Compression ratio	N ₂	>10 ⁸	
	H ₂	>6×10 ³	
Ultimate pressure	Pa	10 ⁻⁷ order [after baking]	
Allowable backing pressure	Pa (Torr)	266 (2): Water cooling/TMS unit used	
Flow rate of purge gas <N ₂ >	Pa·m ³ /s (SCCM)	8.4×10 ⁻² (50)	
Rated speed	rpm	27,500	
Backup rotational speed ^{*1}	rpm	Approximately 6,000	
Starting time ^{*2}	min	8: with SCU-1500 9: with SCU-1400	
Stopping time ^{*2}	min	8: with SCU-1500 11: with SCU-1400	
Noise	dB	<50 (at 27,500 rpm)	
Temperature Management System (TMS)		Available	
Baking temperature	°C	<120	
Lubricating oil		Not necessary	
Installation position		Free	
Cooling method		Water cooling	
Recommended backing-pump	L/min	>1,300	
Mass ^{*3}	kg	75	80
Ambient temperature range	°C	0 to 40	
Storage temperature range	°C	-25 to 55	
Applicable Control unit		SCU-1500/SCU-1400	

^{*1} A backup rotational speed is the lowest rotational speed to which the magnetic bearing can be backed up at a power failure.

^{*2} Time varies depending on the control unit used.

^{*3} Mass is a value of state that the only standard accessory was installed (except the optional accessory).

STP-XA2703/XA3203 Series Turbomolecular Pump

Maximum gas flow-rate ^{*3}

Gas	Condition				Maximum gas flow-rate ^{*3}	
	TMS set point	Cooling pipe	Cooling water	Purge gas N ₂ gas flow rate	[Pa·m ³ /s]	[SCCM]
Ar	No	Built-in	Temperature: 5 to 25 °C Flow rate: 3 L/min	8.4×10 ⁻² Pa·m ³ /s (50 SCCM)	3.21	1900
	No	Option ^{*4}			Max. 3.88	Max. 2300
	70°C	Built-in	Temperature: 5 to 25 °C Flow rate: 3 L/min		2.03	1200
N ₂	No	Built-in	Temperature: 5 to 25 °C Flow rate: 3 L/min		3.89	2300
	70°C	Built-in			2.70	1600

^{*3} The maximum gas flow-rate is applicable under conditions that N₂ or Ar gas is vacuumed continuously and the backing backing-pump (pumping speed: 1,300 L/min) is used. It is changed depending on condition. For example, when the gas is exhausted intermittently, the gas more than the maximum gas flow-rate can be exhausted. In this case, contact Edwards.

^{*4} Contact Edwards for details of additional cooling pipe.

1.1.2 Condition for the water-cooling unit

Item	Specification		
	Without TMS	With TMS	
Port type	Rc 1/4 (Female) ^{*1}		
Flow rate	L/min	3	2
Water temperature	°C	5 to 25	
Water pressure	MPa (kgf/cm ²)	0.3 (3)	

^{*1} Standard type

STP-XA2703/XA3203 Series Turbomolecular Pump

1.2 External appearance of the STP pump

1

TECHNICAL DATA

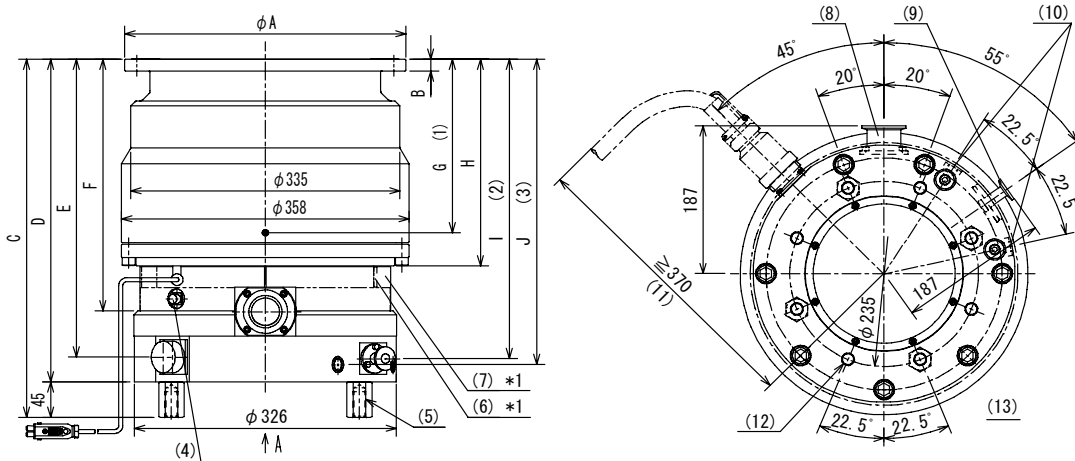

Figure 1 - STP-XA2703 series: VG250/ISO250F/ICF305 (DN250CF)

No.	Item	Description
1	Center of gravity	
2	Height of the purge port	
3	Height of water cooling port	
4	TMS sensor	
5	Screw hole of legs	4-M16 depth 33
6	TMS heater ^{*1}	Built-in
7	TMS heater cover ^{*1}	
8	Outlet port flange	KF40
9	Purge port	KF10
10	Cooling water port	2-Rc ^{*2} 1/4
11	Bending dimension of the STP connection cable	
12	Screw hole for legs	8-M16 depth 24
13	Viewed from arrow A	

Inlet port flange	VG250	ISO250F	ICF305 (DN250 CF)
ϕ A	350	335	305
B	15	15	28
C	454	454	459
D	409	409	414
E	377.5	377.5	383
F	319	319	325
G	250	250	250
H	262	262	267
I	379.5	379.5	385
J	387	387	393

^{*1} TMS used only

^{*2} ISO

STP-XA2703/XA3203 Series Turbomolecular Pump

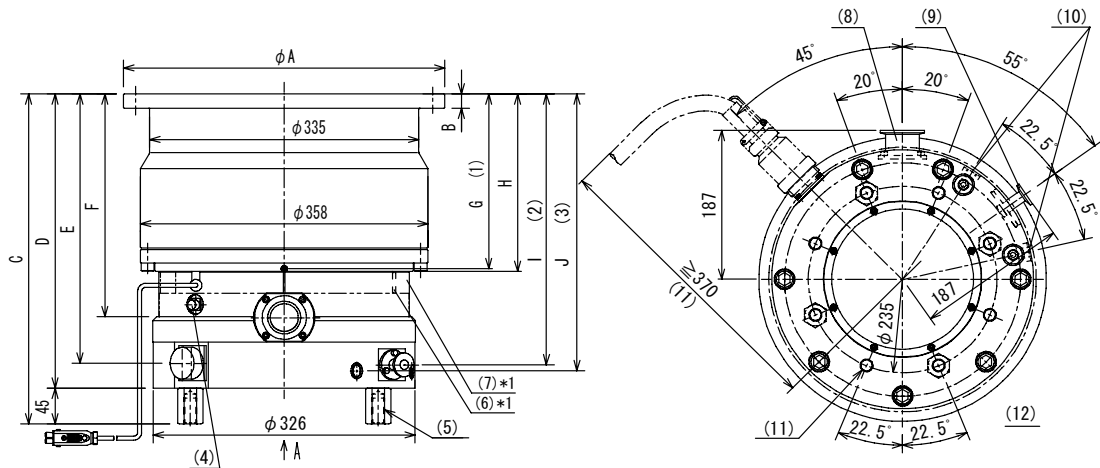

Figure 2 - STP-XA3203 series: VG300/ISO320F/ICF356 (DN320CF)

No.	Item	Description
1	Center of gravity	
2	Height of the purge port	
3	Height of water cooling port	
4	TMS sensor	
5	Screw hole of legs	4-M16 depth 33
6	TMS heater ^{*1}	Built-in
7	TMS heater cover ^{*1}	
8	Outlet port flange	KF40
9	Purge port	KF10
10	Cooling water port	2-Rc ^{*2} 1/4
11	Bending dimension of the STP connection cable	
12	Screw hole for legs	8-M16 depth 24
13	Viewed from arrow A	

Inlet port flange	VG300	ISO320F	ICF356 (DN320 CF)
ϕA	400	425	356
B	18	20	28.5
C	415.5	415.5	454.5
D	370.5	370.5	409.5
E	339	339	378.5
F	280.5	280.5	320.5
G	220	225	215
H	223.5	223.5	262.5
I	341	341	380.5
J	348.5	348.5	388

^{*1} TMS used only

^{*2} ISO

STP-XA2703/XA3203 Series Turbomolecular Pump

1.3 Label affixing positions

Refer to the Instruction Manual (A) for the details of the labels 1 to 7.

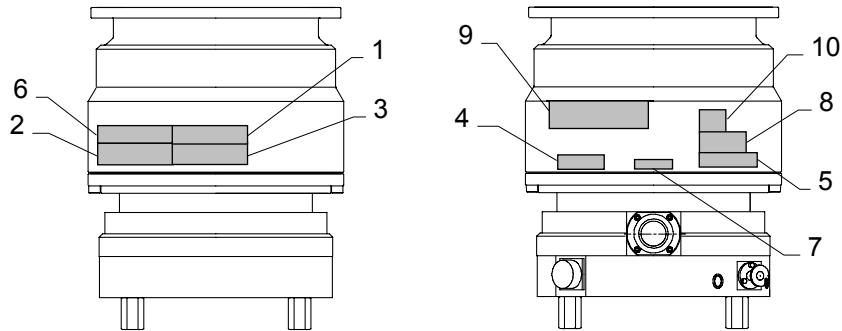

Figure 3 - Label affixing positions for the STP pump

- 1 STP pump installation warning label
- 2 Hot surface warning label
- 3 Heavy product caution label
- 4 Connector caution label
- 5 STP pump/control unit caution label
- 6 TMS heater caution label
- 7 Rotational direction instruction label
- 8 Name plate
- 9 Company logo
- 10 Parts number



STP-XA2703/XA3203 Series Turbomolecular Pump

1.4 Accessories

Item	Q'ty	Remarks
Inlet port cover	1	
Outlet port cover	1	
STP connector cover	1	
Blank flange for purge port	1	KF10
Clamping ring for purge port	1	KF10
O-ring washer for purge port	1	KF10
Leg	4	
Instruction Manual (B)	1	This manual





STP-XA2703/XA3203 Series Turbomolecular Pump

1

TECHNICAL DATA

This page intentionally blank.

2 HOW TO SECURE THE STP PUMP



WARNING

The STP pump is provided with a high-speed rotor. Any internal abnormality/error may result in a jump in rotational torque leading to personal injury or peripheral equipment damage.

The STP pump is provided with a high-speed rotor. The worst-case failure may result in a jump in rotational torque leading to personal injury or peripheral equipment damage.

Secure the STP pump to the vacuum equipment according to the method specified in this manual.

The generated torque during a pump failure is called "Destructive torque". Design and secure the mounting for the STP pump so that it can withstand the maximum rotational torque. Refer to Table 2 and Table 3 for torque in pump abnormality.

Bolt size	Tightening torque (Nm)
M8	12
M10	24
M12	42

Table 1 - Tightening torque of bolt

When making the legs to secure the base, make them shorter than the ones attached to the STP pump. Use a material that has a tensile strength of 600N/mm² or more.

When securing the base, use stainless steel securing bolts with a tensile strength class of 70 or more.

Note: When using any securing method other than that specified in this manual, contact Edwards.

STP-XA2703/XA3203 Series Turbomolecular Pump

The generated destructive torque depends on the presence of a torque reduction mechanism that can be built into the flange, according to the pump model and flange type. This mechanism, shown in Figure 5, is designed to absorb energy and also buffer the destructive torque.

There are two installation methods for the pump, as shown in Figure 4. Make sure to secure the inlet port flange of the pump with the recommended bolts, as described in Table 2 and Table 3, according to the installation method used.

Note that special washers will be required if the pump includes the inlet torque reduction mechanism. The washer shape is shown in Figure 5.

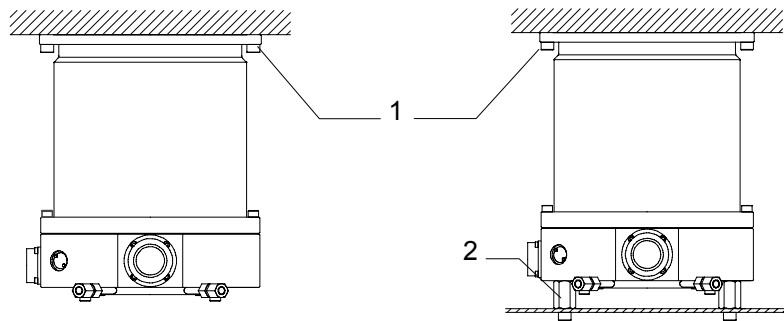

(A) When the base is not secured

(B) When the base is secured

1. Recommended fitting bolt for flange
2. Secure the base

Figure 4 - Methods of securing the STP pump

CAUTION

Install the flange securing bolts in the proper position with the special square washer shown in Figure 5. Failure to do so may cause abnormal operation of the torque reduction mechanism and damage the pump.

CAUTION

When any internal abnormality/error results in high rotational torque, causing the torque reduction mechanism to operate, the pump may rotate a maximum of 5 degrees around the rotor rotation at axis.

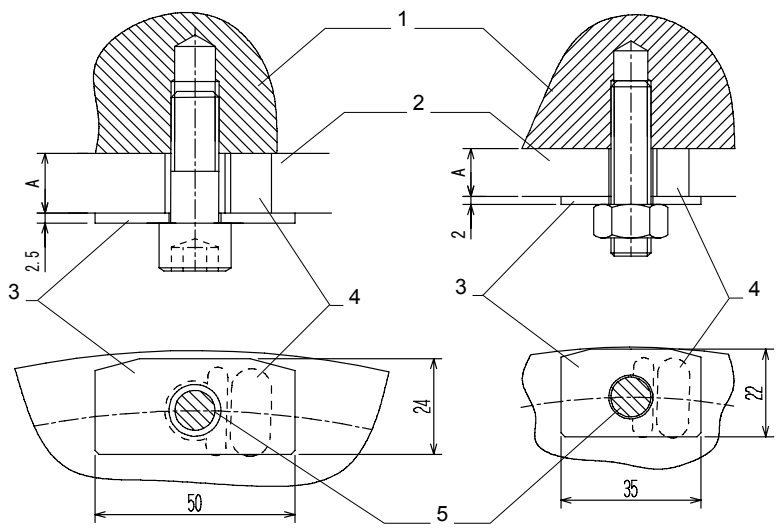

(A) VG250/VG300/VG350/ISO320F

(B) ISO250F

*1 VG250: A=15,
 VG300/VG350: A=18,
 ISO320F: A=20

*1 ISO250F: A=15

1. Vacuum equipment
2. Inlet port flange
3. Washer
4. Torque reduction mechanism
5. Bolt insert position

Figure 5 - Shape of reduced diameter shank bolts

STP-XA2703/XA3203 Series Turbomolecular Pump

Pump model		STP-XA2703 series							
Flange type		ISO250F				VG250			
Toque reduction mechanism		Equipped (standard)		Not Equipped		Equipped (optional)		Not Equipped (standard)	
Destructive Torque [kNm]		48.1		This model is not available		48.1		71.2	
Base (8 positions) securing		No	Yes			No	Yes	No	Yes
Recommended bolt	Shape	Standard	Standard			Standard	Standard	Standard	Standard
	Material ^{*1}	Carbon steel Alloyed steel	Carbon steel Alloyed steel			Carbon steel Alloyed steel	Carbon steel Alloyed steel	Carbon steel Alloyed steel	Stainless steel
	Strength ^{*1}	12.9 or more	12.9 or more	12.9 or more	12.9 or more	12.9 or more	70 or more		
	Special washer	Figure 5 (B)	Figure 5 (B)	Figure 5 (A)	Figure 5 (A)	Not necessary	Not necessary		

Pump model		STP-XA2703 series			
Flange type		ICF305 (DN250CF)			
Toque reduction mechanism		Equipped		Not Equipped (standard)	
Destructive Torque [kNm]		This model is not available		71.2	
Base (8 positions) securing				No	Yes
Recommended bolt	Shape			Standard	Standard
	Material ^{*1}			Carbon steel Alloyed steel	Stainless steel
	Strength ^{*1}	12.9 or more	70 or more		
	Special washer	Not necessary	Not necessary		

^{*1} Refer to ISO898-1 (JISB 1051), ISO3506 (JISB 1054).

Table 2 - Maximum torque predicted and recommended securing bolt for inlet port flange (STP-XA2703 series)

STP-XA2703/XA3203 Series Turbomolecular Pump

Pump model		STP-XA3203 series							
Flange type		ISO320F				VG300/VG350			
Torque reduction mechanism		Equipped (optional)		Not Equipped (standard)		Equipped (optional)		Not Equipped (standard)	
Destructive Torque [kNm]		48.1		71.2		48.1		71.2	
Base (8 positions) securing		No	Yes	No	Yes	No	Yes	No	Yes
Recommended bolt	Shape	Standard	Standard	Standard	Standard	Standard	Standard	Standard	Standard
	Material ^{*1}	Carbon steel Alloyed steel	Carbon steel Alloyed steel	Carbon steel Alloyed steel	Stainless steel	Carbon steel Alloyed steel	Carbon steel Alloyed steel	Carbon steel Alloyed steel	Stainless steel
	Strength ^{*1}	12.9 or more	12.9 or more	12.9 or more	70 or more	12.9 or more	12.9 or more	12.9 or more	70 or more
	Special washer	Figure 5 (A)	Figure 5 (A)	Not necessary	Not necessary	Figure 5 (A)	Figure 5 (A)	Not necessary	Not necessary

Pump model		STP-XA3203 series			
Flange type		ICF356 (DN320CF)			
Torque reduction mechanism		Equipped		Not Equipped (standard)	
Destructive Torque [kNm]		This model is not available		71.2	
Base (8 positions) securing				No	Yes
Recommended bolt	Shape			Standard	Standard
	Material ^{*1}			Carbon steel Alloyed steel	Stainless steel
	Strength ^{*1}	12.9 or more	70 or more		
	Special washer	Not necessary	Not necessary		

^{*1} Refer to ISO898-1 (JISB 1051), ISO3506 (JISB 1054).

Table 3 - Maximum torque predicted and recommended securing bolt for inlet port flange (STP-XA3203 series)



STP-XA2703/XA3203 Series Turbomolecular Pump

2

HOW TO SECURE THE STP PUMP

This page intentionally blank

3 TEMPERATURE MANAGEMENT SYSTEM (TMS)

WARNING

The STP pump operates at high temperatures while the Temperature Management System (TMS) unit is in operation. NEVER touch the STP pump and its peripheral equipment while TMS unit are in operation. Operators can burn hands. Moreover, NEVER remove the TMS cover while the Temperature Management System (TMS) unit is in operation. Doing so may result in electric shock or burnt hands.

The Temperature Management System (TMS) maintains the temperature of the turbomolecular pump by monitoring the temperature with temperature sensor in the base of the turbomolecular pump, and performing the TMS valve and TMS heater ON/OFF control.

3.1 Configuration of the STP pump with the TMS

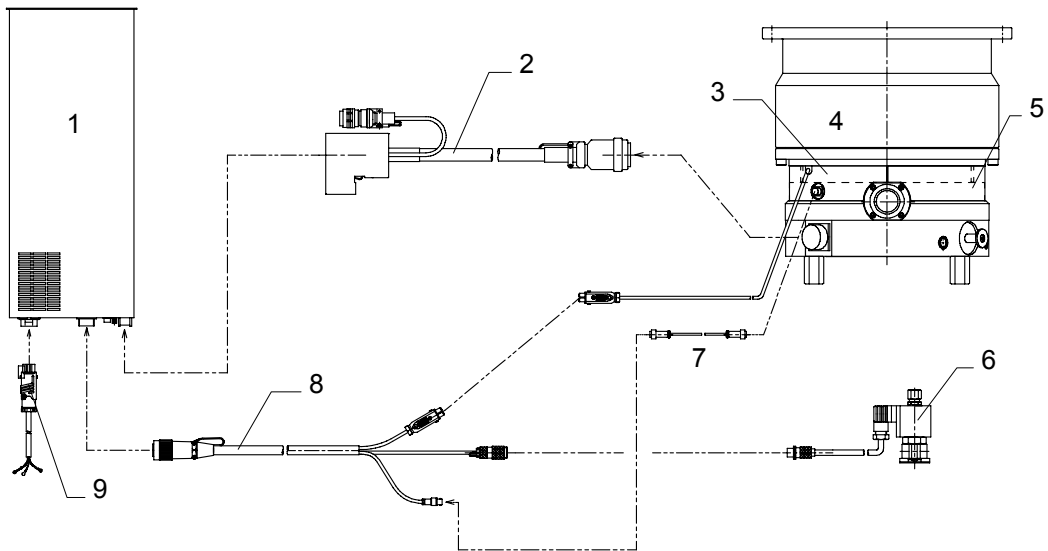

- | | |
|--------------------------|-------------------------|
| 1. STP control unit | 6. TMS valve |
| 2. STP connection cable | 7. TMS sensor cable |
| 3. TMS heater (Built-in) | 8. TMS connection cable |
| 4. STP pump | 9. Power cable |
| 5. TMS heater cover | |

Figure 6 - Configuration of the TMS

Note: The shape of each part is an example. It varies according to specifications.

3.2 TMS connection cable

The components of the TMS connection cables are as follows: (see Figure 7)

Item	Description	Function
1	Connector X5A	For the STP control unit
2	CON1 HEATER OUT connector	For the TMS heater
3	CON2 COOLING VALVE OUT connector	For the TMS valve
4	CON3 TC IN connector	For the TMS sensor cable

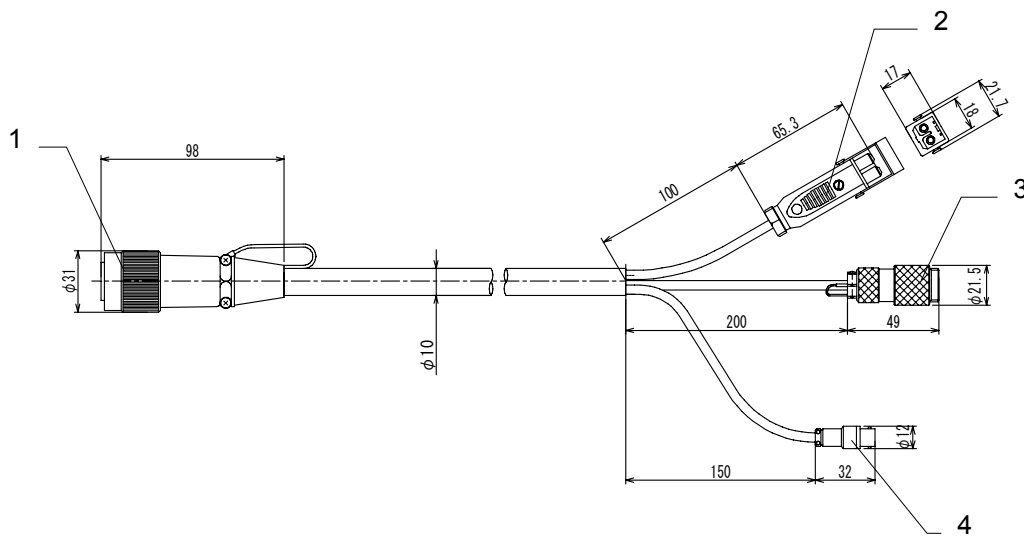

Figure 7 - External view of TMS connection cable

Note: The shape of the TMS connection cable is an example. It varies according to specifications.

STP-XA2703/XA3203 Series Turbomolecular Pump

3.3 TMS heater

The TMS heater heats the base of the STP pump. It's fitted with the STP-XA2703CV/XA3203CV series at the factory.

3.4 TMS valve

The TMS valve controls the cooling water in order to maintain a constant temperature inside the STP pump. The shape of the TMS valve varies according to specifications.

3.5 TMS sensor cable

The TMS sensor cable is for reading the TMS sensor signal from the base of the STP pump.

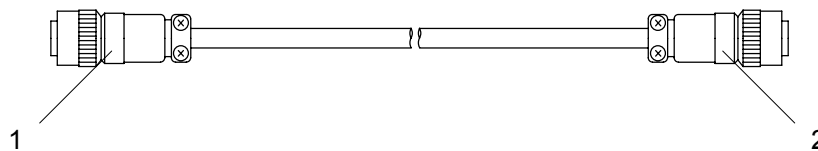

1. TMS connection cable side (5 pin, pin type)
2. STP pump side (5 pin, socket type)

Figure 8 - TMS sensor cable

3.6 Installation of the TMS unit

CAUTION

DO NOT install the TMS unit in places with high temperature, humidity, noise, vibration, or other unstable environment.

CAUTION

DO NOT apply force to the TMS unit and cables during installation and DO NOT bend the cables excessively.

3.6.1 Connecting the TMS connection cable to the STP control unit

Insert the connector X5A of the TMS connection cable into the connector X5 of the STP control unit. (see the "STP control unit Instruction Manual (C)" for the position of the connector X5.)

3.6.2 Connecting the pump and cables

Refer to Figure 6, "Configuration of the STP pump with the TMS" to connect the pump and TMS sensor cable, TMS valve proceed as follows:

1. Connect the TMS sensor cable to the connector of the temperature sensor in the base of the pump.
2. Connect the cooling water pipe to the TMS valve. Pay special attention to the port label on the cooling water valve to connect proper port. Connect the NC side (or OUT side) of the TMS valve to the STP pump, and COM side (or IN side) of the TMS valve to the equipment.

Use cooling water under the conditions in Section 3.7, "Condition for the TMS unit".

Note: Procure and connect the cooling water pipe and affix the electromagnetic cooling water valve at your site. The diameter of the valve is Rc1/4 (ISO standard).

3.6.3 Connecting TMS connection cable to STP pump

Refer to Figure 6, "Configuration of the TMS unit".

Connect the TMS connection cable to the STP pump as follows:

1. Connect the cable for the TMS heater to the "CON1 HEATER OUT" connector of the TMS connection cable.
2. Connect the cable for the TMS valve to the "CON2 COOLING VALVE OUT" connector of the TMS connection cable.
3. Connect the TMS sensor cable to the "CON3 TC IN" connector of the TMS connection cable.

STP-XA2703/XA3203 Series Turbomolecular Pump

3.7 Condition for the TMS unit

The values shown below are typical. They are not guaranteed.

Item	Condition
Ambient temperature range °C	0 to 40
Storage temperature range °C	-20 to 55
Input voltage	Same voltage as the STP control unit 200 to 240 Vac
Temperature control method	Control ON/OFF of the TMS heater and cooling water
Setting temperature °C	Standard type: 70
Cooling water temperature °C	5 to 25
Quantity of cooling water flow L/min	2 or 3 ^{*1}
Alarm output	Alarm outputs from the STP control unit

^{*1} It defers according to condition. Refer to Section 1.1.1, "STP pump specifications".

3.8 Accessories

Item	Q'ty	Condition
TMS heater	1	Attached to the STP pump
TMS connection cable	1	With connector at each end
TMS valve	1	Coupling for water cooling port, cable with connector on one side
TMS sensor cable	1	With connector at each end
TMS heater cover	1	Cover for the TMS heater



STP-XA2703/XA3203 Series Turbomolecular Pump

3

TEMPERATURE MANAGEMENT SYSTEM

This page intentionally blank

For more information, contact the nearest Service Office.

Manufacturer:

Edwards Japan Limited

1078-1, Yoshihashi, Yachiyo-shi, Chiba 276-8523 JAPAN

Telephone:	Domestic	047-458-8822
	International	+81-47-458-8822
Facsimile:	Domestic	047-458-8833
	International	+81-47-458-8833