

Instruction Manual (C)

SCU-750 Control Unit

<i>Description</i>	<i>Voltage</i>
<i>SCU-750 Control Unit</i>	<i>200 - 240 Va.c. 100 - 120 Va.c.</i>



STP pump consists of the three-volumed Instruction Manuals.

Instruction Manual (A):	STP pump generic Instruction Manual Supplied with STP pump
Instruction Manual (B):	STP pump specific information Supplied with STP pump
➔ Instruction Manual (C): (This Instruction Manual)	STP control unit Instruction Manual Supplied with STP control unit



The description of this product consists of the three-volumed Instruction Manuals. Read through each Instruction Manual before operation.

The separate volume contents of each description are as follows:

Instruction Manual (A)

STP pump generic Instruction Manual:

- Introduction
- Installation of the STP pump
- Installation of the STP control unit
- Operation
- Safety functions
- Maintenance and inspection
- Storage and disposal
- Service, Spares and accessories

Instruction Manual (B)

STP pump specific information:

- Technical data
- How to Secure the STP pump
- Temperature Management System (TMS)

Instruction Manual (C)

STP control unit Instruction Manual:

- Introduction
- Technical data
- Installation
- Operation
- Serial communication protocol
- STP-Link (except for SCU-750)
- Maintenance
- Storage, transportation and disposal
- Service, spares, and accessories

Keep the manuals in an easily accessible location.



EC DECLARATION OF CONFORMITY

Manufacture: Edwards Japan Limited
1078-1, Yoshihashi, Yachiyo-shi, Chiba 276-8523, Japan
EU Representative: Edwards Limited
York Road, Burgess Hill, West Sussex RH15 9TT, UK

declare under our sole responsibility that the product

Product Name: Control unit for turbomolecular pump
Model Number: SCU-750
Accessories Covered: TMS Unit, Lon Communication Unit

to which this declaration relates is in conformity with the following standards:

EN 61010-1: 2001
EN 61326: 1997 +A1: 1998 +A2: 1997 (Class A, Group 1)
EN 61000-6-2: 2001

and with the following provisions of EC directive

Low Voltage Directive (2006/95/EC)
EMC Directive (2004/108/EC)

LVD test report is certified by

Certificate number: 03010338
Certification Body: ITS Testing & Certification Ltd.

EMC test report is certified by

Certificate number: E8 03 10 49284 002
Certification Body: TÜV PRODUCT SERVICE GMBH
Zertifizierstelle Ridlerstrasse 65, D-80339 München, Germany

Manufacture:

Yachiyo 10th Aug '07
Place and date

Masaharu Miki
Mr. Masaharu Miki
Director, Technology
Edwards Japan Limited

EU representative:

Crawley, 17th August 2007
Place and date

Stephen E. Ormrod
Dr. Stephen E Ormrod
Technical Director
Edwards Limited

CONTENTS

Section	Title	Page
1	INTRODUCTION	1
1.1	Scope and definitions	1
1.2	Applied standards	2
1.3	Limited warranty	2
1.3.1	Warranty period	2
1.3.2	Item warranted	2
1.3.3	Disclaimer	2
1.3.4	Spare parts	3
1.4	Labels	3
1.5	Label affixing positions	6
1.6	General description	7
1.6.1	Cable sets	8
2	TECHNICAL DATA	9
2.1	SCU-750 specifications	9
3	INSTALLATION	13
3.1	Unpacking	13
3.2	Front panel	13
3.3	Rear panel	15
3.4	Precautions before installation	16
3.4.1	Operating environment	16
3.4.2	Insulation test	16
3.4.3	Installation area	17
3.5	Attaching the SCU-750 to a rack	18
3.6	Cable connection	19
3.6.1	STP connection cable	19
3.6.2	TMS connection cable	21
3.6.3	Power cable	22
3.7	Connecting to semiconductor equipment	24
3.7.1	Connecting to power	24
3.7.2	Emergency off circuit (EMO circuit)	24
3.8	Remote communication	25
3.8.1	Parallel communication	25
3.8.2	Serial communication	25
3.9	Adjustment methods	26
3.9.1	Tuning	26
3.9.2	Tuning method	26
3.9.3	Change of data after tuning	29
3.10	Confirmation mode	30
3.10.1	Confirmation method	30

CONTENTS (CONTINUED)

Section	Title	Page
3.11	Parameter set mode	32
3.11.1	Remote operation setting	32
3.11.2	Serial port setting	33
3.11.3	Factory setting	33
3.11.4	Parameter setting procedure	34
4	OPERATION	37
4.1	Before starting the STP pump	37
4.1.1	Confirmation before starting	37
4.1.2	Confirmation of vacuum system	37
4.2	Powering ON	38
4.2.1	Self test	38
4.2.2	"CAUTION" message in the self test state	38
4.3	How to Start/Stop the STP pump	39
4.4	Manual Start/Stop the STP pump	39
4.4.1	Starting the STP pump	39
4.4.2	Stopping the STP pump	39
4.4.3	Starting the STP pump after stopping	39
4.5	Remote operation	41
4.5.1	Input signal pins	41
4.5.2	Output signal pins	43
4.5.3	Remote setting	46
4.5.4	Starting/Stopping the STP pump	46
4.5.5	Rotation INHIBIT signal	47
4.5.6	Starting the STP pump after stopping	48
4.5.7	Starting the STP pump after a safety function operates	48
4.6	Powering OFF	48
4.7	Operating the TMS unit (for use with the TMS unit)	49
4.7.1	Before starting	49
4.7.2	Starting/Stopping	49
4.7.3	Setting the TMS unit function	49
4.7.4	Temperature control	49
5	SERIAL COMMUNICATION PROTOCOL	51
5.1	Introduction	51
5.2	Connection and setting up	51
5.2.1	Signal connection	51
5.2.2	Connecting the RS485	53
5.2.3	Communication parameter setting	54
5.3	Protocol specifications	54
5.3.1	General description	54
5.3.2	Standard transmission frame (in the RS232/RS485 single port connection)	55
5.3.3	Control command (in the RS232/RS485 single port connection)	56
5.3.4	Query command (in the RS232/RS485 single port connection)	57
5.3.5	Transmission data format	58
5.3.6	Frame control (Checksum)	59
5.3.7	Error control	59

CONTENTS (CONTINUED)

Section	Title	Page
5.3.8	Transmission frame in the RS485 multi-port connection	59
5.3.9	Control command in the RS485 multi-port connection	61
5.3.10	Query command in the RS485 multi-port connection	62
5.3.11	Broadcasting command in the RS485 multi-port connection	63
5.4	Command specifications	64
5.4.1	Command list	64
5.4.2	ReadMeas	65
5.4.3	Command	65
5.4.4	ReadFailMess	66
5.4.5	ReadModFonct	69
5.4.6	ReadVersion	71
5.4.7	ReadCounters	72
5.4.8	ReadSetPoint	73
5.4.9	ReadMotorTemp	73
5.4.10	ReadStatus	74
5.4.11	ReadEvents	75
5.4.12	SetSpeedSetPoint	76
5.4.13	ReadSpeedSetPoint	77
5.4.14	ReadMeasValue	78
6	MAINTENANCE	81
6.1	Safety functions	81
6.1.1	Power failure	81
6.1.2	Operation after a power recovery	82
6.1.3	Abnormal state of magnetic bearing	83
6.1.4	Excessive vibration	83
6.1.5	Motor driver overload	83
6.1.6	Overheating inside the STP pump	83
6.1.7	Overheating inside the SCU-750	83
6.1.8	Overspeed	84
6.1.9	Abnormality/Error in the TMS unit (for use with the TMS unit)	84
6.2	"WARNING" message function	85
6.2.1	"WARNING" message display function	85
6.3	"WARNING" message description	86
6.3.1	Damage point function	86
6.3.2	First damage limit	86
6.3.3	Second damage limit	86
6.3.4	CAUTION X_H, X_B, Z	87
6.4	Error at self test state	88
6.4.1	Error after self test	88
6.4.2	Error messages	89
6.4.3	Troubleshooting immediately after power failure occurs	89
6.4.4	Troubleshooting immediately after other abnormality/errors occur	89
6.5	When error message is not displayed on LCD	96
6.5.1	Abnormalities when powering ON	96
6.5.2	Abnormalities when performing rotational operation	96
6.5.3	Other abnormalities	97
6.6	"Error Record" message display function	97
6.7	Maintenance and inspection	98

CONTENTS (CONTINUED)

Section	Title	Page
6.7.1	Cleaning	98
6.7.2	Overhaul	98
7	STORAGE, TRANSPORTATION AND DISPOSAL	99
7.1	Storage of the SCU-750	99
7.1.1	Transporting for repair or overhaul	99
7.2	Disposal	100
8	SERVICE, SPARES, AND ACCESSORIES	101
8.1	Introduction	101
8.2	Service	101
8.3	Spares	101
8.4	Accessories	102

ILLUSTRATIONS

Figure	Title	Page
1	High voltage device caution label	3
2	Voltage caution label	4
3	Safety instruction label	4
4	Caution label	4
5	Connector caution label	4
6	Voltage rating label	5
7	Label affixing positions	6
8	SCU-750 control unit	7
9	Configuration of the STP pump with the TMS	8
10	SCU-750 dimensions (mm)	11
11	SCU-750 front panel	13
12	SCU-750 rear panel	15
13	Installing the SCU-750	17
14	Example of securing the SCU-750	18
15	STP pump connection cable	19
16	TMS connection cable (standard)	21
17	TMS connection cable (STP-A1603 series)	21
18	Power cable	22
19	Connecting method of the power cable without plug	23
20	REMOTE X7 connector	25
21	Connector X3A, X3B (D-sub 9)	25
22	Tuning procedures	28
23	Confirmation mode	31
24	Parameter setting method	35
25	Parameter setting method (continued)	36
26	Operational procedures	40
27	REMOTE X7 input signal pins	43
28	REMOTE X7 output signal pins	45
29	Serial communication	51
30	Serial port connector	52
31	RS485 connections	53
32	PC to SIM communication	55

TABLES

Table	Title	Page
1	Turbomolecular pumps	7
2	SCU-750 front panel functions	14
3	SCU-750 rear panel connection	15
4	STP connection cable specification	20
5	Power cable	23
6	User setting data list	29
7	Causes of "CAUTION" at the self test state	38
8	REMOTE X7 input signal pins	42
9	REMOTE X7 output signal pins	44
10	Rated contacts for relays CR1 to CR8	46
11	Starting/Stopping the STP pump during remote operation (REMOTE X7)	46
12	Rotation INHIBIT signal input	47
13	Reset operation during remote operation (REMOTE X7)	48
14	X3A/X3B pin position	51
15	Communication parameters	54
16	Transmission control characters	55
17	Pump operation commands	63
18	Command list	64
19	Pump operation commands	66
20	Error message values	68
21	Error message values (continued)	69
22	Pump operation mode	70
23	Remote mode	75
24	Backup rotational speed	81
25	States of LCD, LEDs and REMOTE output signals at a power failure	82
26	Accumulated damage point and warning message	86
27	Error messages at self test state	88
28	Error messages after self test	90
29	Error messages after self test (continued)	91
30	Error messages after self test (continued)	92
31	Error messages after self test (continued)	93
32	Error messages after self test (continued)	94
33	Error messages after self test (continued)	95
34	Troubleshooting when powering ON	96
35	Troubleshooting when performing the STP pump start operation	96
36	Troubleshooting while the STP pump is rotating	97

1 INTRODUCTION

1.1 Scope and definitions

This manual provides installation, operation and maintenance instructions for the Edwards SCU-750 control unit (abbreviated to "SCU-750" throughout this manual) for the Turbomolecular pump (STP). You must use the SCU-750 as specified in this manual.

The procedures in this manual must be followed before you install, operate and maintain the SCU-750. Important safety information is highlighted as WARNING and CAUTION instructions; these instructions are mandatory. The use of WARNINGS and CAUTIONS is defined below.

	WARNING Warnings are given where failure to observe the instruction could result in serious injury or death to people.
---	--

CAUTION Cautions are given where failure to observe the instruction could result minor personal injury in damage to the equipment, associated equipment and/or process.

Note: Items you must follow during operation and maintenance.

Throughout this manual, page, figure and table numbers are sequential.

The units used throughout this manual conform to the SI international system of units of measurement; US equivalent units of measurement are also given.

The following IEC warning labels/symbols appear on the SCU-750:



Warning - refer to accompanying documentation.



Warning - risk of electric shock.



Protective earth (ground).

Note: An alarm function is incorporated into this STP series. Alarm and cautionary messages are displayed on the LCD of the SCU-750. Note that the words "WARNING" and "CAUTION" displayed on the LCD indicate the need for overhaul of the pump or precautions during the operation. They do not have the same meaning as the much more serious symbols for "WARNING" and "CAUTION" used in the instruction manual.

SCU-750 Control Unit for Turbomolecular Pump

1.2 Applied standards

The SCU-750 conforms to the following directives and standards:

1. Applied Directives
 - EC Low Voltage Directive
 - EC Electromagnetic Compatibility Directive
2. Applied Standards
 - EN61010-1 / IEC61010-1
 - EN61326 (class A)
 - UL61010A-1 (Electrical Equipment for Measurement, Control, and Laboratory Use)

1.3 Limited warranty

This WARRANTY applies to the customer to whom Edwards has delivered this product.

1.3.1 Warranty period

Edwards warrants this product against defects for a period of two (2) years from the date of delivery or during the period specified in the agreement made by and between the customer and Edwards.

1.3.2 Item warranted

1. This warranty applies only to the product delivered from Edwards to the customer.
2. If any defect is found during this period, Edwards will, at its option, repair or recondition the product free of charge. The costs for repair or replacement of the product after the warranty period has passed will be at your own charge.

1.3.3 Disclaimer

Edwards makes no warranty with respect to any damage occurred due to any of the following during the warranty period:

1. Handling, operation or maintenance other than that specified herein.
2. Failure to follow any of the warnings or cautions enumerated in this manual.
3. Installation, operation or maintenance using parts which are not specified by Edwards.
4. Maintenance personnel other than those authorized by Edwards or Service office have disassembled, reconditioned, or tampered the product.

SCU-750 Control Unit for Turbomolecular Pump

5. Defect resulting from the not-specified use of the product.
6. When the product is used under special conditions without obtaining the written consent of Edwards (strong magnetic field and the radiation are added to the product).
7. Defect resulting from the installation of the product (exclude the installation by authorized personnel).
8. Deterioration in the external because of use (discoloration, scratches and so forth).
9. Product damage occurred during transport or other factors not attributable to Edwards.
10. Product breakage or damage due to natural disasters, fire or other external factors.
11. Deterioration in the basic performance due to the use of the product beyond limits of the use.
12. Any direct, incidental or consequential damage resulting from the use of the product.
13. When continuously operated without overhaul after the WARNING indication ("WARNING" message) on the LCD.
14. Overhaul and replacement of maintenance parts.

1.3.4 Spare parts

- Air-cooling fan for SCU-750. (When exchanging, contact Edwards)

1.4 Labels

The following labels are affixed or printed to the SCU-750. Read the contents of the labels before operation.

1. High voltage device caution label

The SCU-750 is equipped with a high voltage device. This label warns operators to pay attention to the high voltage device at the maintenance and inspection.

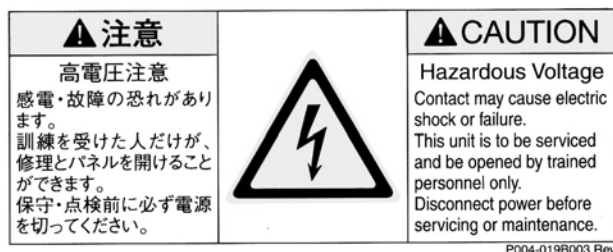

Figure 1 - High voltage device caution label

SCU-750 Control Unit for Turbomolecular Pump

2. Voltage caution label

This label describes precautions for operating the TMS unit.
Use the specified heater and valve when connecting the TMS unit to the STP pump.

▲注意		▲CAUTION	
◇TMSユニット使用時はヒータ・バルブの電圧表示を確認し、表示に合った入力電圧で使用してください。異なる電圧で使用した場合、ヒータ・バルブが故障する恐れがあります。		◇Before using the TMS unit, always check the voltage specified on its heater and valve. The specified input voltage should be used. If not, the heater and valve may be damaged.	
ヒータ・バルブ表示	入力電圧	Mark on heater and valve	Input Voltage
220V	AC200V-240V~	220V	AC200V-240V~
110V	AC100V-120V~	110V	AC100V-120V~

P004-019B004 Rev.A

Figure 2 - Voltage caution label

3. Safety instruction label

This label describes instructions before operating the SCU-750.

安全上の指示事項	SAFETY INSTRUCTIONS
使用前に取扱説明書をお読みください。	Read instruction manual before operation.

Figure 3 - Safety instruction label

4. Caution label

This label describes precautions for operating the SCU-750. Follow these precautions.

▲注意	▲CAUTION
◇必ず指定の型式のケーブルを使用してください。	◇Use only designated type of cables.

Figure 4 - Caution label

5. Connector caution label

This label describes lock of the connector.
The label instructs operators to prevent the connectors from being disconnected while the STP pump is in operation.

▲注意	Lock	▲CAUTION
感電や故障の原因になります。 ◇コネクタは確実にロックしてください。 ◇ブレーカONの時はコネクタを外さないでください。		Improper connection may cause electric shock or failure. ◇Lock connector securely. ◇Do not remove connector while breaker is ON.

P004-019B005 Rev.-

Figure 5 - Connector caution label

SCU-750 Control Unit for Turbomolecular Pump

6. Voltage rating label

This label describes the rated voltage of the SCU-750. Use voltage specified in this label. Some pumps can be operated in the input voltage between 100 - 120 V inclusive. Confirm the specific pumps in Section 2.1, "SCU-750 Specifications".

AC100-120V 8A~*/200-240V 6A~
*Applicable only for specific model

6-a

	AC200-240V~ 1 φ 50/60Hz	AC100-120V~ 1 φ 50/60Hz
without TMS	850VA MAX	800VA MAX
with TMS	1200VA MAX	800VA MAX

6-b

Figure 6 - Voltage rating label

SCU-750 Control Unit for Turbomolecular Pump

1.5 Label affixing positions

Refer to Section 1.4 for the details of the labels 1 to 6.

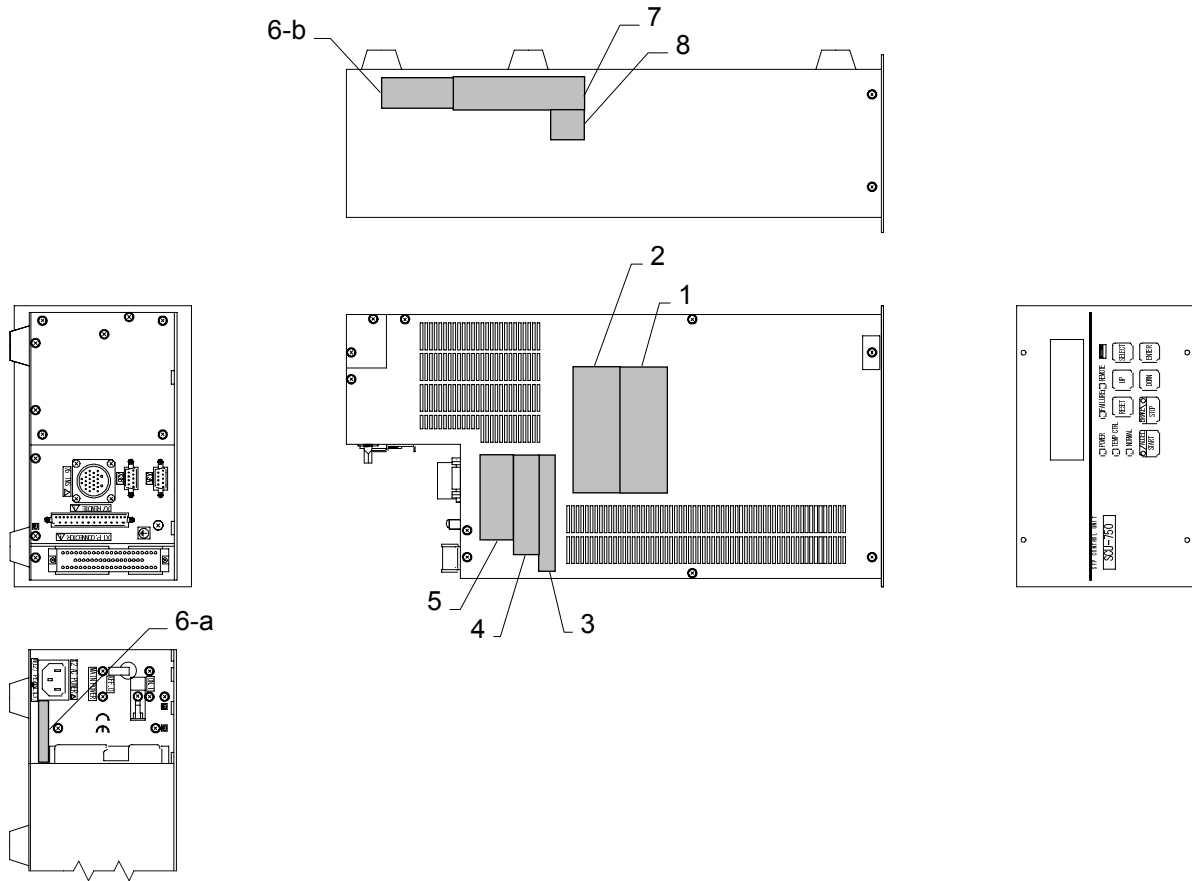

Figure 7 - Label affixing positions

- 1 High voltage device caution label
- 2 Voltage caution label
- 3 Safety instruction label
- 4 Caution label
- 5 Connector caution label
- 6-a Voltage rating label
- 6-b Voltage rating label
- 7 Name plate
- 8 Parts number

SCU-750 Control Unit for Turbomolecular Pump

1.6 General description

The SCU-750 is the control unit required to drive the STP series of turbomolecular pumps. The SCU-750 converts the single-phase line supply voltage into a 3-phase d.c. voltage to drive the pump motor. It also evaluates measured signals and performs the following functions:

- It provides logic to control the pump functions.
- It operates the magnetic bearing system.
- It operates the optional Temperature Management System (TMS).

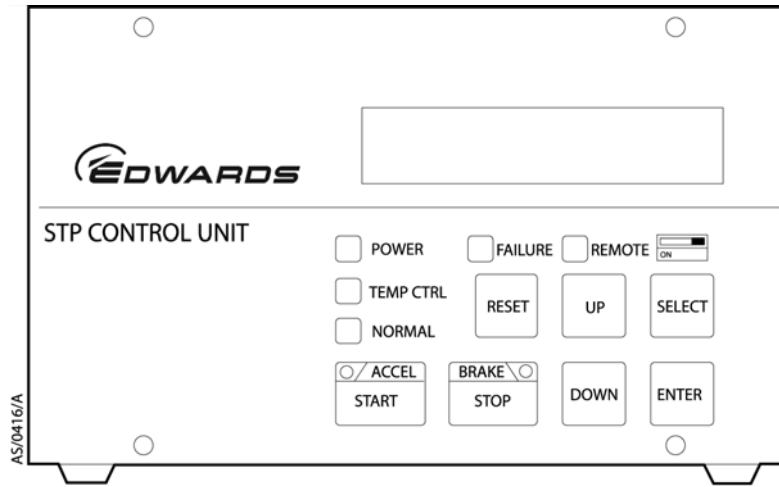

Figure 8 - SCU-750 control unit

The following series of turbomolecular pumps can be used in conjunction with the SCU-750.

Model Name	Specification
STP-603/1003 series	High-vacuum type
STP-H301/H451 series	High-throughput type
STP-H803/H1303 series	High-throughput type
STP-A803/A1303 series	Advanced high-throughput type
STP-A1603 series	Advanced high-throughput type

Table 1 - Turbomolecular pumps

SCU-750 Control Unit for Turbomolecular Pump

1.6.1 Cable sets

The following cable sets (optional accessories) are used with the SCU-750 and STP pump:

- STP connection cable - STP pump to SCU-750.
- TMS cable - STP pump to built-in TMS unit in the SCU-750.
- Power cable - SCU-750 to power supply.

Note: Figure 9 shows a typical TMS system installation. System connections and cables differ according to the type of pump connected to the SCU-750. Refer to the STP pump Instruction Manual (A) and (B) for full details of connection cables and system connections.

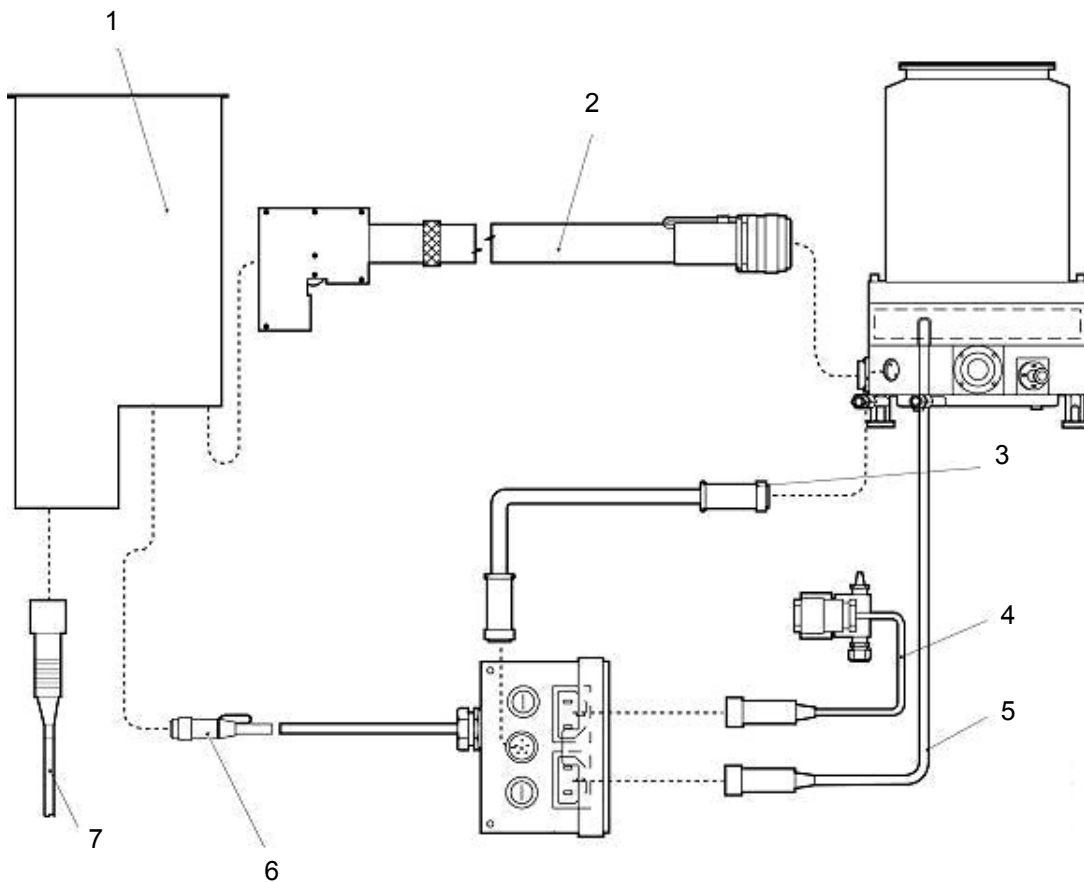

- | | |
|-------------------------|-------------------------|
| 1. SCU-750 control unit | 5. TMS heater cable |
| 2. STP connection cable | 6. TMS connection cable |
| 3. TMS sensor cable | 7. Power cable |
| 4. TMS valve cable | |

Figure 9 - Configuration of the STP pump with the TMS

2 TECHNICAL DATA

2.1 SCU-750 specifications

Applicable pump		STP-603/1003 series STP-H301/H451 series STP-H803/H1303 series STP-A803/A1303 series STP-A1603 series
Input voltage:	For STP-603/1003 series	100 to 120 Va.c. \pm 10%, 200 to 240 Va.c. \pm 10%
	For STP-H301/H451 series	100 to 120 Va.c. \pm 10%, 200 to 240 Va.c. \pm 10%
	For STP-H803/H1303 series	200 to 240 Va.c. \pm 10%
	For STP-A803/A1303 series	200 to 240 Va.c. \pm 10%
	For STP-A1603 series	200 to 240 Va.c. \pm 10%
Input power:	Without TMS unit	850 VA maximum
	With TMS unit	1200 VA maximum
Input frequency		50/60 \pm 2 Hz
Leakage current		3.5 mA maximum
Input phase		Single phase
Main breaker specification	Rated current	10 A
	Ampere Interrupting Capacity (AIC)	1000 A (240 Va.c. 50/60 Hz)
Motor driving system		3-phase d.c. brushless motor driver
Output voltage under normal operation		92 Va.c. maximum
Output frequency under normal operation		800 Hz maximum
Allowable ambient temperature		0 to 40 °C (32 to 104 °F)
Storage temperature		-25 to 55 °C (-13 to 131 °F)
Mass (except the optional accessory)		8.5 kg (18.74 lb)
Dimensions		Refer to Figure 10
TMS control unit		Built in
Serial communication function		RS232/RS485

SCU-750 Control Unit for Turbomolecular Pump

Operation switch	START	(Push-button switch•Green)
	STOP	(Push-button switch•Dark grey)
	RESET	(Push-button switch•Grey)
	SELECT	(Push-button switch•Grey)
	UP	(Push-button switch•Grey)
	DOWN	(Push-button switch•Grey)
	ENTER	(Push-button switch•Grey)
	MANUAL/REMOTE changeover	(Slide switch•White)
Panel indication LED	ACCEL.	(Green LED)
	NORMAL	(Green LED)
	BRAKE	(Green LED)
	TEMP CTRL	(Green LED)
	POWER	(Green LED)
	FAILURE	(Red LED)
	REMOTE	(Green LED)
Panel display	LCD	(2 lines of 20 characters)
Input/Output terminal	AC POWER X2	(3 pins)
	P.CONNECTOR X1	(60 pins)
	TMS X5	(26 pins)
	REMOTE X7	(37 pins)
	COM X3A/X3B	(9 pins x 2)
Safety function	Electromagnetic bearing failure detection STP pump overheat detection Motor driver overload detection Power failure detection STP pump overspeed detection STP control unit overheat detection TMS unit failure detection Other failure detection	

SCU-750 Control Unit for Turbomolecular Pump

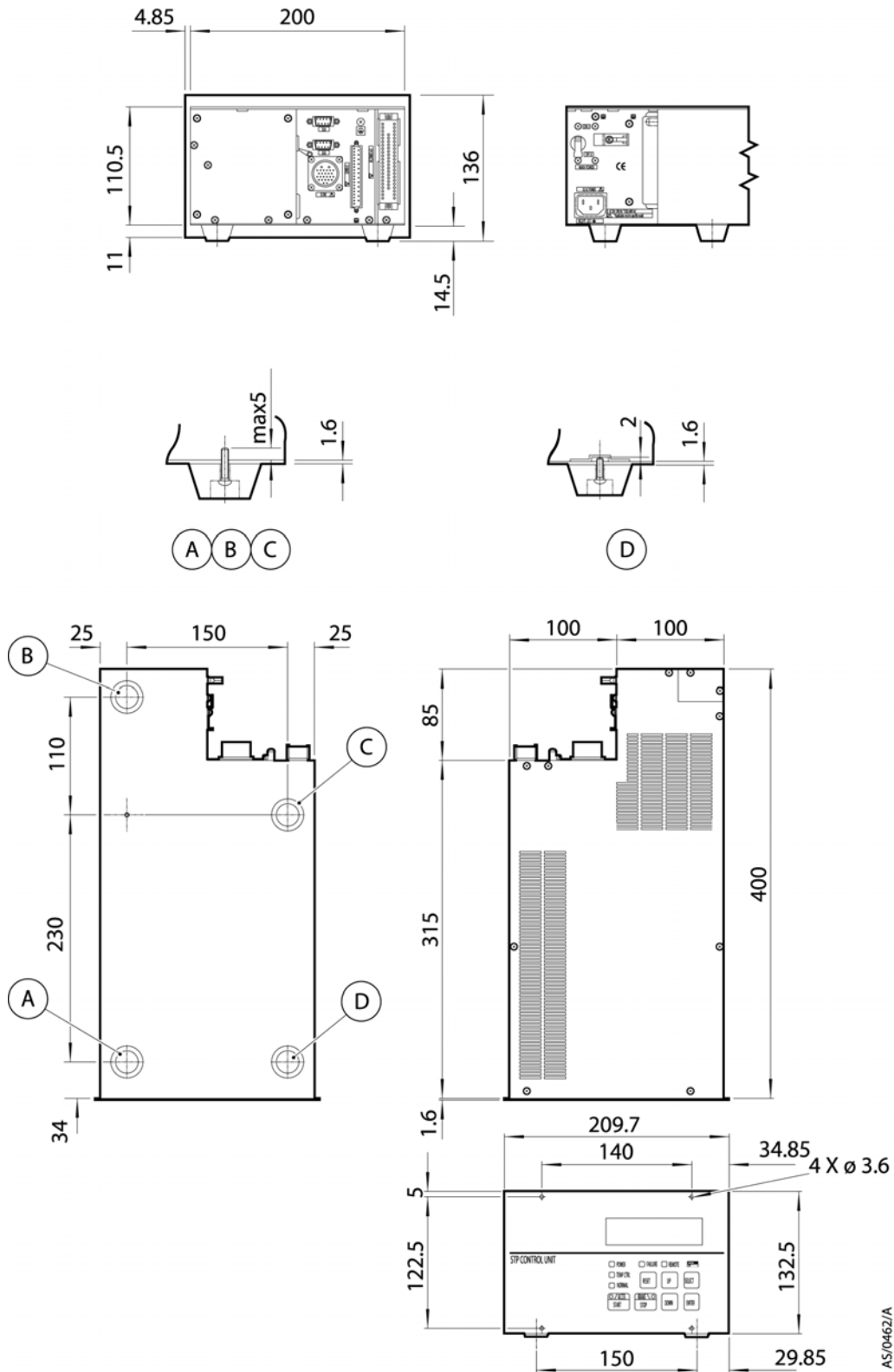

Figure 10 - SCU-750 dimensions (mm)

Note: The screw hole sizes for the rubber feet and rack fixation are 5-M4.



SCU-750 Control Unit for Turbomolecular Pump

This page intentionally blank.

3 INSTALLATION

3.1 Unpacking

Check outer package for damage and that the delivery note corresponds to the purchase order.

Note: It is recommended to keep the packaging materials, such as the corrugated fibreboard container and cushioning material for possible re-use. If the SCU-750 is damaged, return it in its original package and contact Edwards or their distributor.

3.2 Front panel

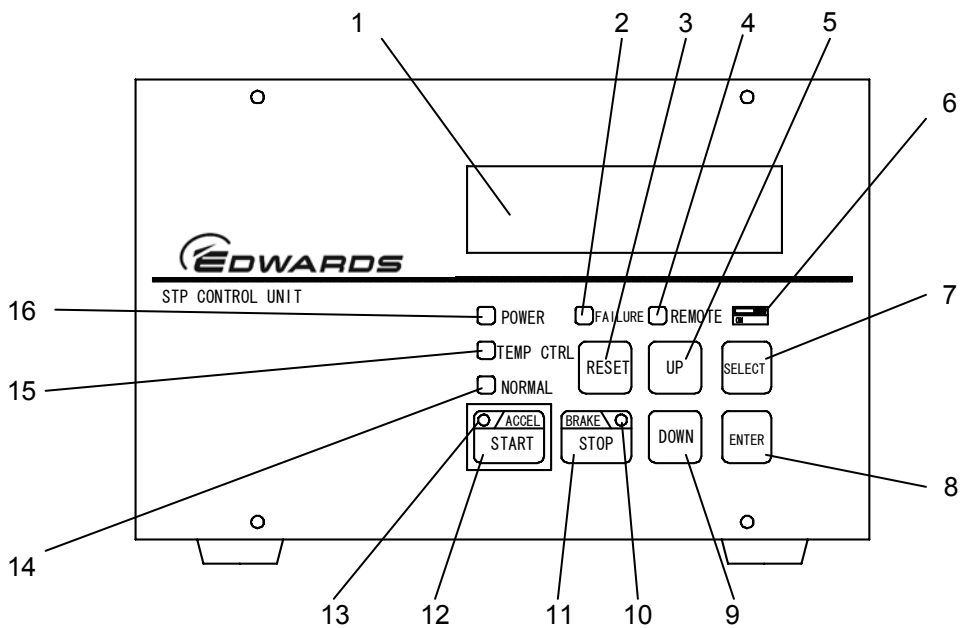

- | | |
|------------------------------------|-------------------|
| 1. LCD panel | 9. DOWN switch |
| 2. FAILURE LED | 10. BRAKE LED |
| 3. RESET switch | 11. STOP switch |
| 4. REMOTE LED | 12. START switch |
| 5. UP switch | 13. ACCEL. LED |
| 6. MANUAL/REMOTE changeover switch | 14. NORMAL LED |
| 7. SELECT switch | 15. TEMP CTRL LED |
| 8. ENTER switch | 16. POWER LED |

Figure 11 - SCU-750 front panel

Note: Refer to Table 2 for front panel functions.

SCU-750 Control Unit for Turbomolecular Pump

Item	Description	Function
1	LCD panel	Displays the STP pump's operational status, speed, error messages, and other.
2	FAILURE LED	(Red LED) Illuminates when an abnormality/error occurs on the STP pump or SCU-750. LCD panel simultaneously displays an error message.
3	RESET switch	(Flat panel switch, grey. Valid in MANUAL only.) Alarm reset function. Tuning function.
4	REMOTE LED	(Green LED) Illuminates when in the REMOTE mode.
5	UP switch	(Flat panel switch, grey. Valid in MANUAL and REMOTE.) Abnormality/error display change function. Setting content confirmation function. Setting content change function.
6	MANUAL/REMOTE changeover switch	(Slide switch, white) Manual/Remote mode changeover.
7	SELECT switch	(Flat panel switch, grey. Valid in MANUAL and REMOTE.) LCD display function (Confirmation mode change and parameter set mode change). Press UP and SELECT switches simultaneously to enter the setting mode.
8	ENTER switch	(Flat panel switch, grey. Valid in MANUAL and REMOTE.) Setting content determination function. Warning message display function.
9	DOWN switch	(Flat panel switch, grey. Valid in MANUAL and REMOTE.) Abnormality/error display change function. Setting content confirmation function. Setting content change function.
10	BRAKE LED	(Green LED) Illuminates during STP pump deceleration (BRAKE state).
11	STOP switch	(Flat panel switch, dark grey. Valid in MANUAL only.) Stops the STP pump.
12	START switch	(Flat panel switch, green. Valid in MANUAL only.) Starts the STP pump.
13	ACCEL. LED	(Green LED) Illuminates during STP pump acceleration (ACCELERATION state).
14	NORMAL LED	(Green LED) Illuminates during STP pump rated speed operational (NORMAL OPERATION state).
15	TEMP CTRL LED	(Green LED) Illuminates when the TMS unit (optional accessory) is operational.
16	POWER LED	(Green LED) Illuminates when power is on. Extinguishes when backup power is being supplied.

Table 2 - SCU-750 front panel functions

SCU-750 Control Unit for Turbomolecular Pump

3.3 Rear panel

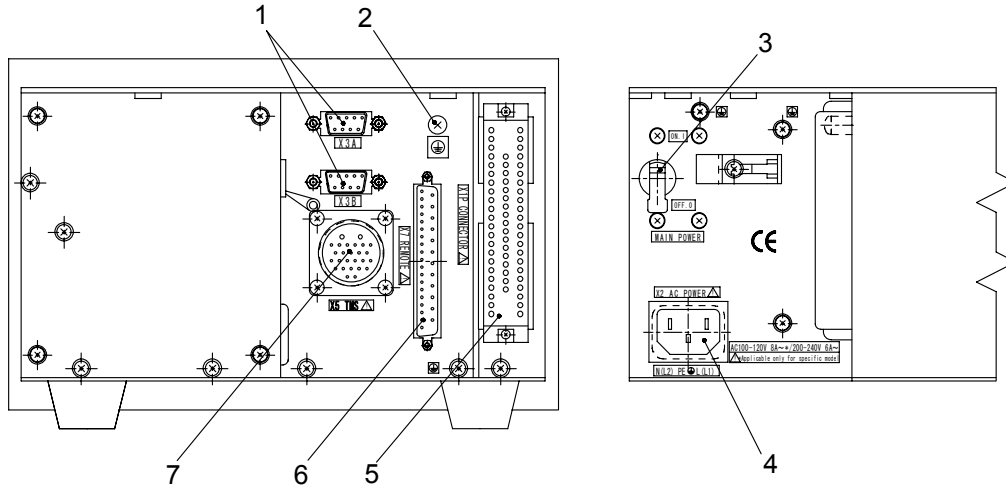

- | | |
|-----------------------------|--------------------|
| 1. Serial port COM X3A, X3B | 5. P.CONNNECTOR X1 |
| 2. Ground terminal | 6. REMOTE X7 |
| 3. MAIN POWER breaker | 7. TMS X5 |
| 4. AC POWER X2 | |

Figure 12 - SCU-750 rear panel

WARNING

A hazardous live voltage may exist at the connectors that are marked with the warning sign .

DO NOT touch the terminal. Doing so may result in electric shock.

When connecting/disconnecting the terminal connections, always power OFF the SCU-750 (turn the MAIN POWER "OFF").

Item	Description	Function
1	Serial port COM X3A/X3B	Serial communication connection RS232/RS485 (shard use)
2	Ground terminal	Ground (Earth) connection terminal
3	MAIN POWER breaker	Main power circuit breaker
4	AC POWER X2	Main power connection (240 Va.c. maximum)
5	P.CONNNECTOR X1	STP pump connection (92 Va.c. maximum)
6	REMOTE X7	Remote connection (125 Va.c. maximum)
7	TMS X5	TMS unit connection (240 Va.c. maximum)

Table 3 - SCU-750 rear panel connection

SCU-750 Control Unit for Turbomolecular Pump

3.4 Precautions before installation

CAUTION

When removing or installing the pump or at maintenance and inspection, follow the precautions below. Failure to do so might hurt your back or cause injuries due to occurrence of an accident CAUTION such as fall.

- Use a crane or the like when lifting the heavy product of 18 kg or more.
- When lifting STP control unit with handles, support bottom of STP control unit, do not have only handle.

CAUTION

DO NOT move the STP pump and the STP control unit while the STP pump is in operation. Doing so may result in product damage.

3.4.1 Operating environment

The SCU-750 should be installed in an area which meets the following requirements:

Ambient temperature	0 to 40 °C (32 to 104 °F)
Ambient relative humidity	30 to 95 % (non condensing)
Environment	An area free of exposure to direct sunlight, high humidity, dust, salty air, dripping water, explosive or flammable gas, corrosive gas, radiation, strong magnetic and electric fields, excessive vibration and sources of electric noise
Installation condition	Install the SCU-750 horizontally (within ±10 degrees)

3.4.2 Insulation test

CAUTION

The varistor for the power supply line protection is installed in the SCU-750. DO NOT perform the insulation test with the varistor installed. Doing so may result in product damage.

DO NOT perform an insulation test on the SCU-750. When performing the insulation test on your equipment, ensure that you disconnect the SCU-750 from the equipment that is to be insulation tested, so that the test voltage is not applied to the SCU-750.

3.4.3 Installation area

CAUTION

The minimum bending radius of the STP connection cable is 100 mm (4").
DO NOT bend the cables excessively and beware of any obstacles when installing the SCU-750.
 In addition, leave enough space to install other cables without bending them excessively.

When installing the SCU-750, leave enough space for the following (refer to Figure 13):

- Space for maintenance and inspection.
- Space for inlet and outlet cooling air:
 Top and side: 50 mm (1.97") or more.
 Bottom: 14.5 mm (0.57") or more (height of the rubber feet).
- Space for connecting the cables:
 Rear: 115 mm (4.53") or more.

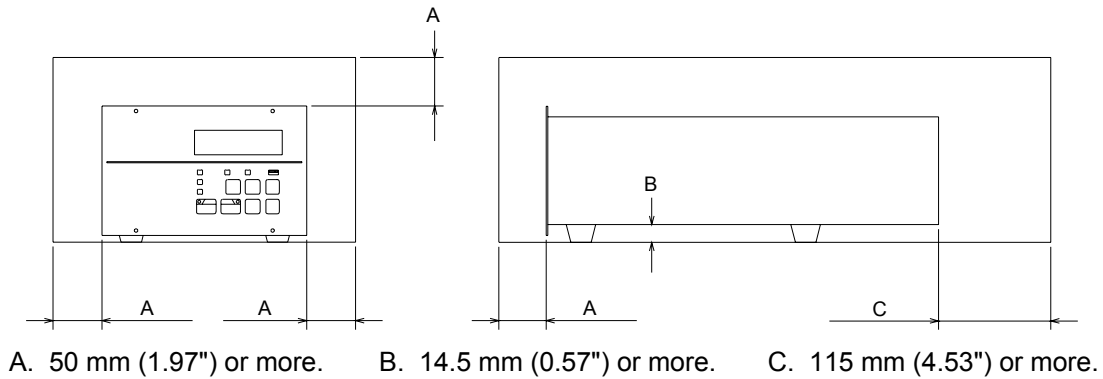

Figure 13 - Installing the SCU-750

3.5 Attaching the SCU-750 to a rack

3

INSTALLATION

CAUTION

The SCU-750 cannot be supported with only the 4 screws on the front panel. Always support it from the bottom using a support angle. When installing the SCU-750, DO NOT block the ventilation port of the SCU-750 by the support angle or other things. It will cause the SCU-750 to overheat.

The dimensions of the SCU-750 front panel conform to EIA standards. Therefore, this panel can be attached to any type of commercially available rack. Attach the SCU-750 as follows:

Note: For the dimensions of the front panel and positions of the screw holes for the rubber feet, refer to Figures 9 and Figure 14.

- Attach the front panel to the rack using the 4 screws Figure 14 (1).
- Support the SCU-750 from the bottom using a support angle Figure 14 (2) or a similar tool.
- When attaching the SCU-750 to a movable rack, to protect the SCU-750 during transport, remove the rubber feet from the bottom and attach the SCU-750 to the rack using the screw holes for the rubber feet.

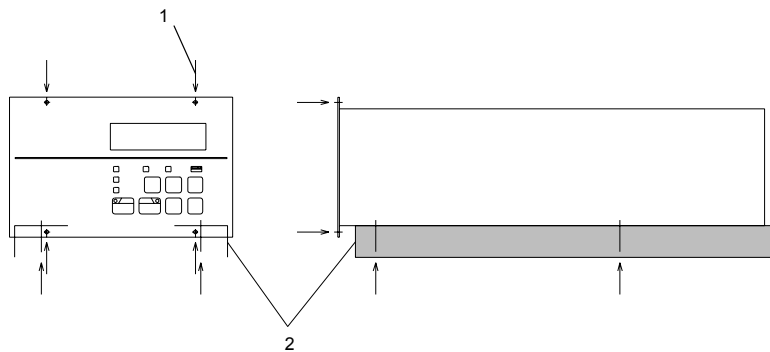

1. Front panel 4 securing screws 2. Mounting support

Figure 14 - Example of securing the SCU-750

3.6 Cable connection



WARNING

When connecting/disconnecting cables, always power off the STP pump (switch the SCU-750 MAIN POWER to "OFF") and isolate the electrical energy source (Lockout/Tagout) on the vacuum equipment. Failure to do so may result in an electric shock or damage to equipment. Failure to do so may cause the STP pump to rotate accidentally, which may injure operators seriously or result in electric shock. Moreover, DO NOT remove the connector while the pump is rotating. The voltage might be output to connector according to the rotational speed, and it causes the electric shock or the failure.

CAUTION

Use the STP connection cable and the power cable that Edwards has specified. The use of other cables may result in product damage. Align the position of the guide key of the connectors and insert vertically so as not to bend the pins. If a pin is bent, not only may the connector not function normally, but it may make the pins contact, resulting in a malfunction. Lock and securely tighten each connector and screw.

CAUTION

Connect each cable securely with caution, avoiding any obstacles. DO NOT place heavy objects on the cables or bend them excessively. Support each cable so as not to apply direct force to the connectors or terminals. If any problem occurs in cables, connectors or terminals, the STP pump may not function normally. DO NOT apply voltage to each connector pin and DO NOT cause any short-circuiting between pins. Install cables so that personnel are not exposed to risk of tripping or falling.

3.6.1 STP connection cable

Connect the receptacle (socket) side of the STP connection cable to the STP connector on the STP pump and connect the plug (pin) side to "P.CONNECTOR X1" on the SCU-750.

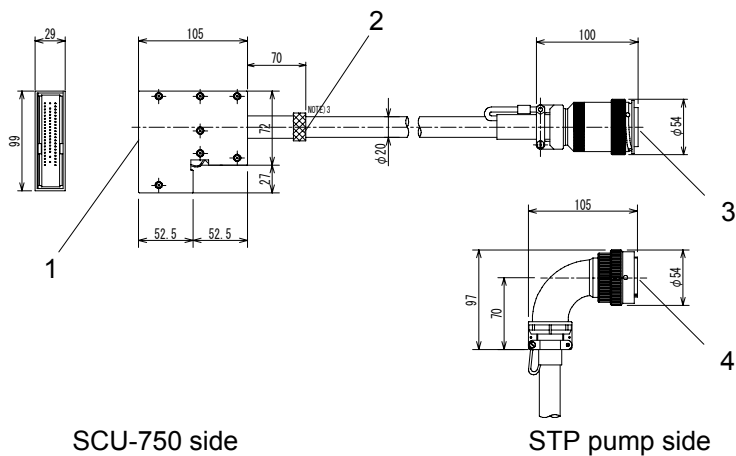

1. 60 pin (pin) 2. Blue label 3. 60 pin (socket) 4. 60 pin (socket, L-Type connector)

Figure 15 - STP pump connection cable



SCU-750 Control Unit for Turbomolecular Pump

CAUTION

The STP connection cable has the different specification according to the presence of a blue label. When operating the STP-A1603 series with the TMS unit using the STP connection cable without a blue label, the TMS unit does not operate (see Table 4).

STP connection cable	TMS unit	Available STP pump
With blue label	Not use	STP-603/1003 series
	Use	STP-H301/H451 series STP-H803/H1303 series STP-A803/A1303 series
Without blue label	Not use	STP-A1603 series
	Use	STP-603/1003 series STP-H301/H451 series STP-H803/H1303 series STP-A803/A1303 series

Table 4 - STP connection cable specification

SCU-750 Control Unit for Turbomolecular Pump

3.6.2 TMS connection cable

The SCU-750 TMS unit is used with specified STP pumps. Refer to the STP pump Instruction Manual (B) for the cable connection method.

Note: Figure 16 shows a typical TMS cable. For details of the TMS cable used with the connected pump module, refer to the STP Pump Instruction Manual (B).

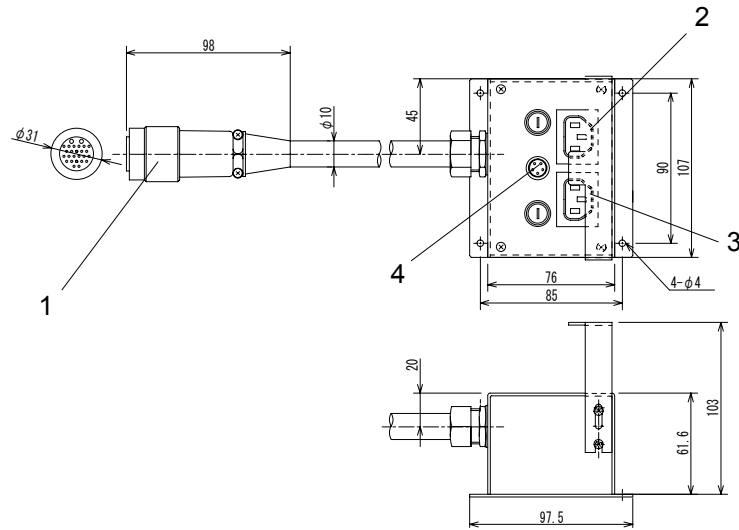

SCU-750 side

STP pump side

- | | |
|-------------------------------|--------------------------------|
| 1. SCU-750 connection | 3. TMS heater cable connection |
| 2. TMS valve cable connection | 4. TMS sensor cable connection |

Figure 16 - TMS connection cable (standard)

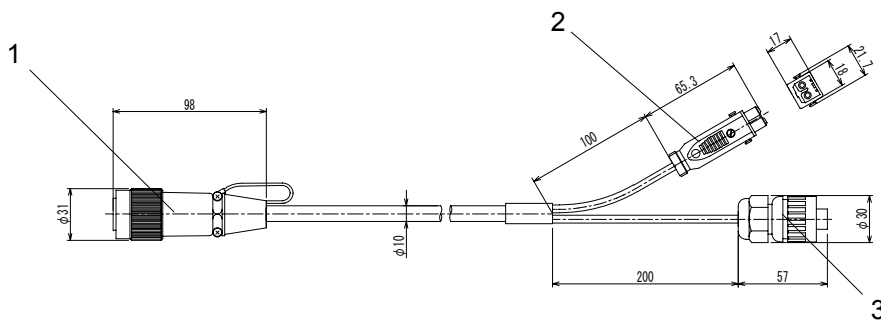

SCU-750 side

STP pump side

- | | |
|--------------------------------|-------------------------------|
| 1. SCU-750 connection | 3. TMS valve cable connection |
| 2. TMS heater cable connection | |

Figure 17 - TMS connection cable (STP-A1603 series)

3.6.3 Power cable

3

INSTALLATION

	<p>WARNING</p> <p>Ensure that the SCU-750 and the electrical supply cable are suitably protected against earth (ground) faults and that the earth (ground) of the SCU-750 and "AC POWER X2" are correctly connected.</p>
--	---

<p>CAUTION</p> <p>The power cable is designed specifically for the STP pump. DO NOT use the power cable with other products.</p> <p>Connect the power cable securely to prevent any poor or cross connections. DO NOT apply voltages exceeding 1 kV to the input line.</p> <p>Ensure that the supply voltage is as indicated on the SCU-750 information label. Connect the power cable to the "AC POWER X2" connector on the SCU-750.</p>
--

Connect the power cable for the SCU-750 side to the "AC POWER X2" on the SCU-750 rear panel as shown in Table 5.

Connect the suitable connector to the power supply as shown in Table 5.

When using the power cable without plug, connect them to the UL-recognized terminal block as shown in Figure 19. Secure the terminals with M4-bolts as the other side of the terminals, and cover the terminal block with an appropriate cover. (refer to Figure 19)

Note: The primary power cable is not included. Contact the distributor to purchase the primary power cable.

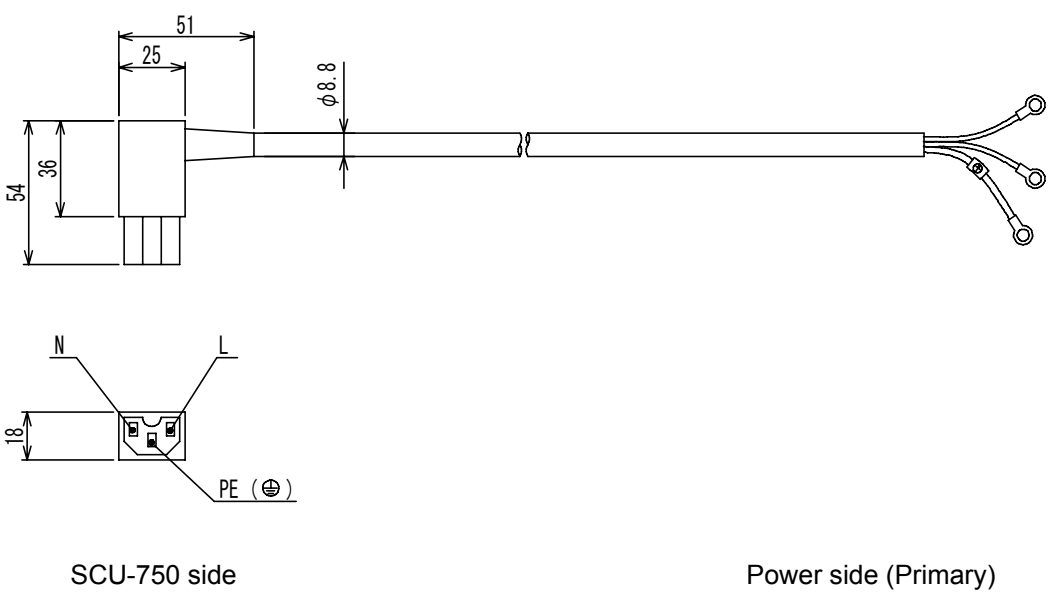
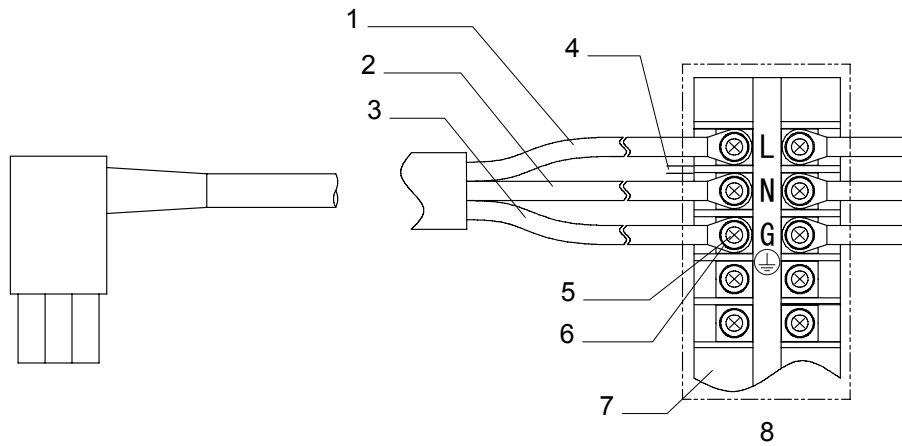

Figure 18 - Power cable

SCU-750 Control Unit for Turbomolecular Pump

CON1 pin	Cable colour	Remarks
L	Brown or Black 1	Single-phase 200 to 240 Va.c. (200V specification), 50/60 Hz, 6A maximum or Single-phase 100 to 120 Va.c. (100V specification), 50/60 Hz, 8A maximum
N	Blue or Black 2 or White	
PE (⊕)	Yellow/Green	Earth (ground)

Table 5 - Power cable



SCU-750 side

Power side (Primary)

- | | | | |
|---|-------------------------|---|------------------------------|
| 1 | Brown or Black1 | 5 | M4-bolt (fixing screw) |
| 2 | Blue or Black2 or White | 6 | Crimp-type terminal (M4) |
| 3 | Yellow/Green | 7 | Cover ^{*1} |
| 4 | Clearance min. 1.5 mm | 8 | Terminal block ^{*2} |

^{*1} Use material flammability: UL 94V-0

^{*2} Use the UL-recognized terminal block satisfying with the following conditions;

- Clearance (between each terminal): 1.5 mm or more
- Material flammability: UL 94V-0
- The installation category II.

Figure 19 - Connecting method of the power cable without plug

SCU-750 Control Unit for Turbomolecular Pump

3.7 Connecting to semiconductor equipment

The STP pump is a component system when installing to the semiconductor equipment. Consider the following when designing the semiconductor equipment.

3.7.1 Connecting to power

The SCU-750 receives its power from the semiconductor equipment electrical distribution system via a circuit breaker.

Electrical energy isolation (Lockout/Tagout) is achieved by opening the main disconnect device or circuit breaker of the semiconductor equipment, thereby removing power from the STP pump.

Provide the equipment with the main disconnect or circuit breaker devices rated for at least 10,000 A_{rms} symmetrical amperes interrupting capacity (AIC).

3.7.2 Emergency off circuit (EMO circuit)

Activation of EMO circuit of the equipment will interrupt electrical power from the SCU-750.

When the power is shut off, the STP pump performs the same as a power failure. (After backup operation of a power failure, the rotor lands on the touch down bearing)

Consider the following when establishing the EMO circuit.

CAUTION

Unite the exhaust gas system to prevent atmosphere from being introduced into the STP pump when the EMO circuit operates (example: shut the valve). When atmosphere is introduced into the STP pump, the touch down bearing may not operate normally.

CAUTION

The STP pump rotates for a while after the EMO circuit shuts off the power. Perform a recovery operation after the STP pump has stopped completely.

CAUTION

Before performing the operation check of the EMO circuit with regular maintenance, stop the STP pump to prevent damage to the touch down bearing.

*Note: Procure the main disconnect device and the EMO circuit at your company.
Use the main disconnect device which is lockable only in the de-energised position.
Locate the main disconnect device and the EMO button in the place where personnel are readily accessible and are not exposed to any hazards during operation.*

SCU-750 Control Unit for Turbomolecular Pump

3.8 Remote communication

3.8.1 Parallel communication

The SCU-750 is fitted with a remote communication port, "REMOTE X7" (refer to Figure 20) to allow remote input and output signal control via input and output remote signals. This connector is a D-Sub type (37-pins, socket type) that conforms to MIL-C-24308. The screw for connector is M2.6.

Note: This D-Sub type connector is not supplied. Procure the connector for remote connection at your company.

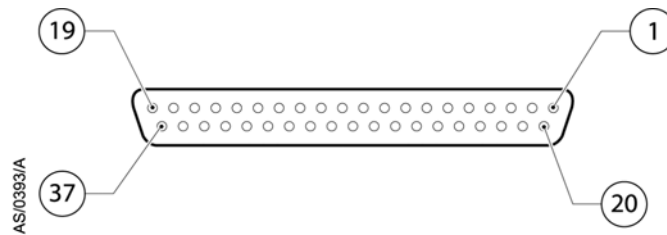

Figure 20 - REMOTE X7 connector

3.8.2 Serial communication

The SCU-750 is fitted with a remote communication port, "Connector X3A, X3B" (refer to Figure 21) to allow remote input and output signal control by serial protocol. This connector is a D-Sub type (9-pins, socket type) that conforms to MIL-C-24308. The screw for connector is M2.6.

Note: This D-Sub type connector is not supplied. Procure the connector for remote connection at your company.

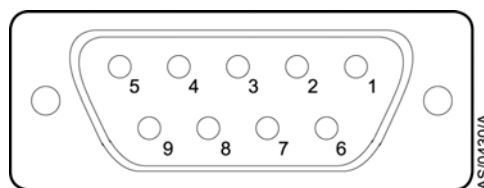

Figure 21 - Connector X3A, X3B (D-sub 9)

3.9 Adjustment methods

3.9.1 Tuning

Tuning is required to align the position of levitation in the STP pump axial direction with the centre of the rotor's movable range. Tuning can be performed simply by pressing the "RESET" switch on the front panel (refer to Figure 7).

Tuning is required in the following cases in which the position of levitation may deviate from the centre of the rotor's movable range:

- When purchasing only the SCU-750 and connecting to the STP pump for the first time.
- When changing the length of the STP connection cable (not when changing the length of the power cable).
- Connecting the same model but a different serial number of the STP pump to the SCU-750 after the tuning is performed. (The error message "CAUTION : New Serial Number" is displayed upon performing the self test)
- Connecting a different model of the STP pump to the SCU-750 after the tuning is performed. (The error message "CAUTION : New pump Model" is displayed upon performing the self test)

3.9.2 Tuning method

CAUTION

DO NOT turn off the primary power (DO NOT switch the MAIN POWER "OFF") during tuning. If the power is interrupted, perform tuning again. "CAUTION: Incorrect Pump & Ctrl Data" may be displayed after powering ON again. When tuning is performed with this message, the setting is initialized. Reconfigure the setting if it has been changed.

Refer to Figure 22.

1. Ensure all cables are connected.
2. Turn "ON" the MAIN POWER on the SCU-750 rear panel.
3. After the STP pump completes the self test and "Levitation" is displayed, set the MANUAL/REMOTE changeover switch to the MANUAL and press the "RESET" switch on the front panel for approximately 5 seconds. When the LCD displays "Tuning", release the "RESET" switch. The tuning is performed automatically.
4. When an error message such as "CAUTION : New Serial Number" or "CAUTION : New Pump Model" is displayed during the autotest (at this time, it is alternately displayed with the message of "Re-tuning Necessary! Press RESET 5sec"), press the "RESET" switch on the front panel for approximately 5 seconds. When the LCD displays "Updating Data", release the "RESET" switch. "Tuning" is displayed after a few seconds and the tuning is performed automatically. (refer to Section 4.2.2)
5. Approximately 1 minute later the LCD displays "Tuning Complete", and then displays "Levitation". This completes the tuning.



SCU-750 Control Unit for Turbomolecular Pump

Note: Tuning can be performed only while the STP pump is in the LEVITATION state. (It cannot be performed while the STP pump is in the ACCELERATION, NORMAL OPERATION, or BRAKE state)

When performing the tuning during remote operation, press the "RESET" switch on the front panel after switching the "REMOTE" switch to MANUAL. (The remote signal cannot be used for tuning)

Once tuning is completed, re-tuning is not required unless the configuration (the STP pump serial number, the SCU-750 serial number, and the STP connection cable length) is changed.

Although the STP pump produces an abnormal noise during tuning, this is not an indication of abnormality.

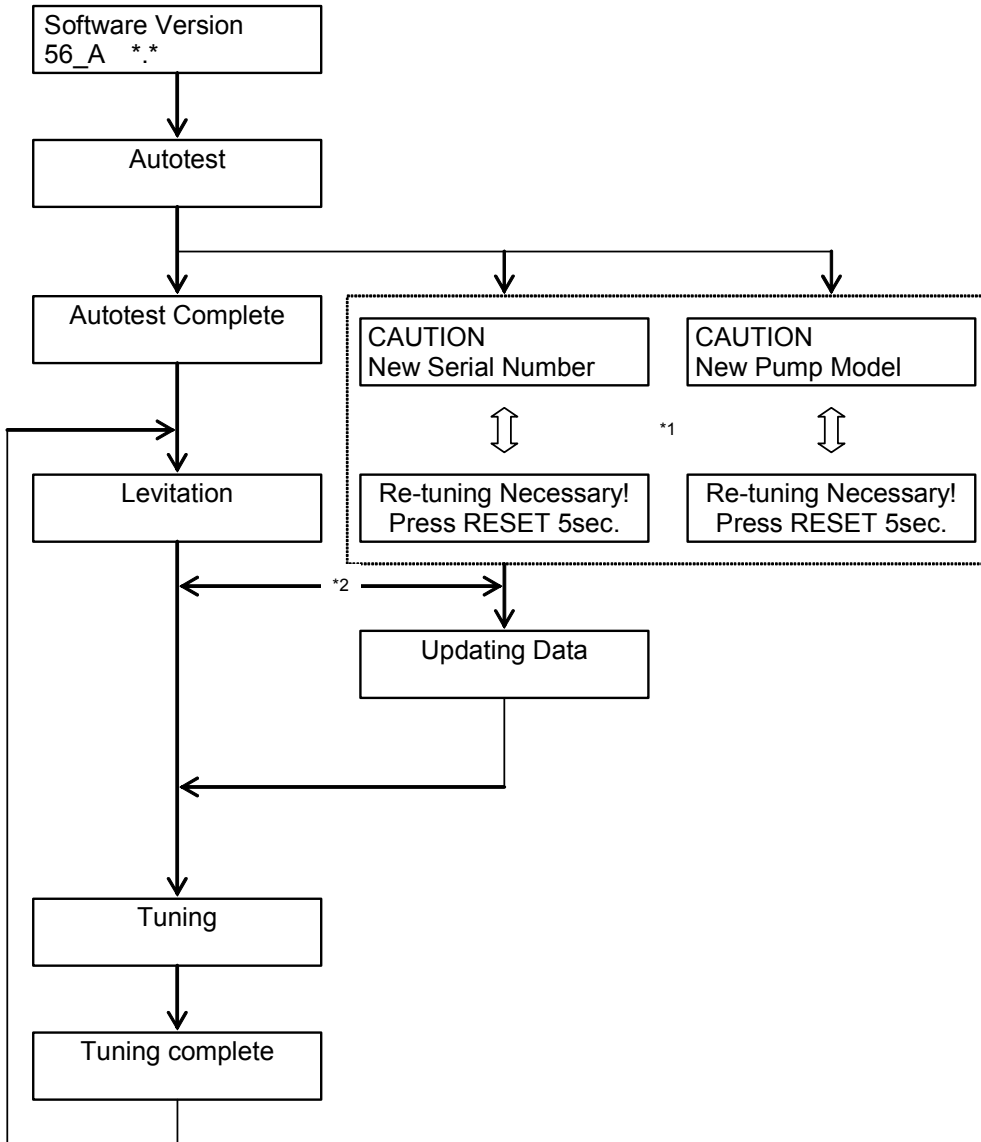

*1 Displays alternately.

*2 Press the RESET switch for approximately 5 seconds.

Figure 22 - Tuning procedures

SCU-750 Control Unit for Turbomolecular Pump

3.9.3 Change of data after tuning

The user setting may be changed because of the change of the configuration of the STP pump and STP control unit after "CAUTION" message is displayed.

Confirm the setting shown in Table 6 after tuning, and reconfigure the setting when the user setting has changed.

For the setting confirmation, refer to Sections 3.10 and 3.11.

Items		Factory setting (reference)	
Remote mode		I/O Remote	
Rotational Speed		Rated speed	Varies according to STP pump type.
TMS function		DISABLE	ENABLE (in the case of the TMS specification).
Inhibit function		DISABLE	
Emergency vent valve		DISABLE	
Second Damage Limit		ENABLE	
Serial port	Baud rate	9600 bps	
	Bit length	8	
	Stop bit	1	
	Parity	None	
	Driver type	RS232	
	Node address	1	

Table 6 - User setting data list

3.10 Confirmation mode

Confirmation mode is used to check the status of the STP pump and SCU-750. The following items can be checked in Confirmation mode:

1. Version information.
2. Individual information (serial number, total hours of running, number of starts and damage of the bearing).
3. Current settings (rotational speed, TMS temperature setting, actual pump temperature and actual motor current).
4. Current function settings (remote mode, TMS function, inhibit function, and emergency vent valve).
5. Error record (lists up to 10 errors. The most recent error is number 1. "1/n" denotes the most recent error.).

3.10.1 Confirmation method

Refer to Figure 23.

1. Press the "SELECT" switch to enter the Confirmation mode.
The available menu groups (Section 3.10 steps (1) through (5)) are displayed in order.
2. Press the "UP" switch to display the next menu item. Press the "DOWN" switch to display the previous menu item.
3. Press the "SELECT" switch to display the next menu group.
4. Press the "UP" and "DOWN" switch to confirm the status of the items of the currently selected menu group.
5. Press the "SELECT" switch to return to Operation mode when viewing the Error Record.
If no switch is pressed for approximately 1 minute, the display will automatically revert to Operation mode.

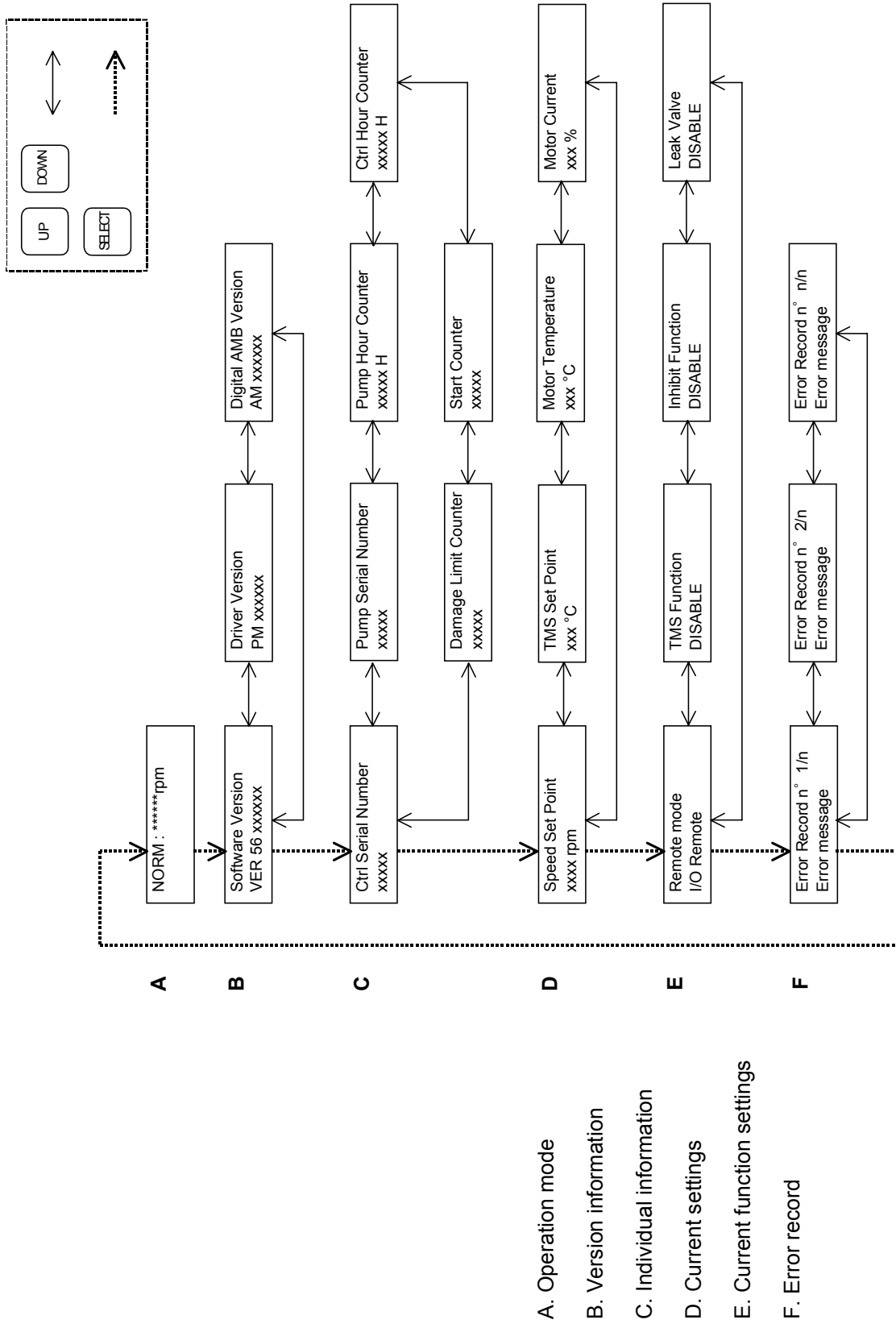

Figure 23 - Confirmation mode

3.11 Parameter set mode

Parameter set mode is used to set the different parameters of the STP pump and SCU-750.

3.11.1 Remote operation setting

The remote parallel port (I/O REMOTE) and serial ports (X3A/X3B) are fitted on the SCU-750 as standard connectors for the remote operation. The hardware is selected for the remote operation setting of the start, stop and reset. Refer to Section 4.5 and Section 5 for the remote operating methods. The remote output monitoring the operating state can be output with any hardware.

1. Rotational speed setting

The rotational speed can be changed in units of 500 rpm in the NORMAL state. The variable range is from half of the rated speed to the rated speed. The rated speed is different according to the connected pump.

2. TMS setting

Enable/Disable the TMS control function.

3. Rotational inhibit signal setting

Enable/Disable the rotation inhibit signal.

4. Emergency vent valve setting

Enable/Disable the emergency vent valve function. When a failure of the magnetic bearing is detected, in the state of effective, the emergency vent valve operates. Disable the function when the emergency vent valve is not fitted on the STP pump connected to the SCU-750.

5. Second Damage Limit

Enable/Disable the rotational operation after "Second Damage Limit" occurs. When setting to "ENABLE", "START NOT ALLOWED" is displayed and the rotational operation cannot be performed. When setting to "DISABLE", "Second Damage Limit" is displayed, though the rotational operation can be performed.

3.11.2 Serial port setting

Note: When the remote mode is set to "I/O Remote", the serial port settings are not displayed.

1. Baud rate
Set the communication speed. Maximum 19,200 bps can be set.
2. Bit length
Set the bit number of the communication data to 7 or 8.
3. Stop bit
Set the stop bits number to 1 or 2.
4. Parity
Presence or absence of parity check. In the case of presence, select even number or odd number.
5. Driver type
Set to either the RS232, RS485 Single or RS485 Multipoint.
6. Node address
Set the identification number in the RS485 Multipoint. (1 to 127).

3.11.3 Factory setting

The set value of the factory setting is shown in Table 6.

3.11.4 Parameter setting procedure

Refer to Figure 24 and Figure 25.

1. Press the "UP" and "SELECT" switches simultaneously to enter the Parameter Set Mode. The setting options detailed in Section 3.11.1 to steps 1 to 5 are each displayed in order.
2. Press the "UP" switch to go to the next parameter, and press the "DOWN" switch to display the previous parameter.
3. Press the "ENTER" switch to set the new parameter and to enter the next menu. However, note that the new parameter is not accepted until it is stored (refer to step 6 below).
4. When the parameter is not required to be set, press the "SELECT" switch and go to the next menu.
5. Use the same procedure 1 to 4 above to set the remaining parameters.
6. "STORAGE NO" is displayed on the preservation menu. Select "YES" with the "UP" or "DOWN" switches and press "ENTER" to store the parameter. The message on the LCD displays "STORAGE IN PROGRESS". When the storage is completed, "STORAGE OK" is displayed. However, if the storage fails, "STORAGE FAILURE" is displayed, press "SELECT" switch and repeat steps 1 to 6 above.
7. Press the "SELECT" switch when the LCD "STORAGE OK" is displayed to go to the operation mode.

Note: If no switch is pressed for approximately 1 minute, the display will automatically revert to Operation mode. In this case, unsaved settings are not changed.

SCU-750 Control Unit for Turbomolecular Pump

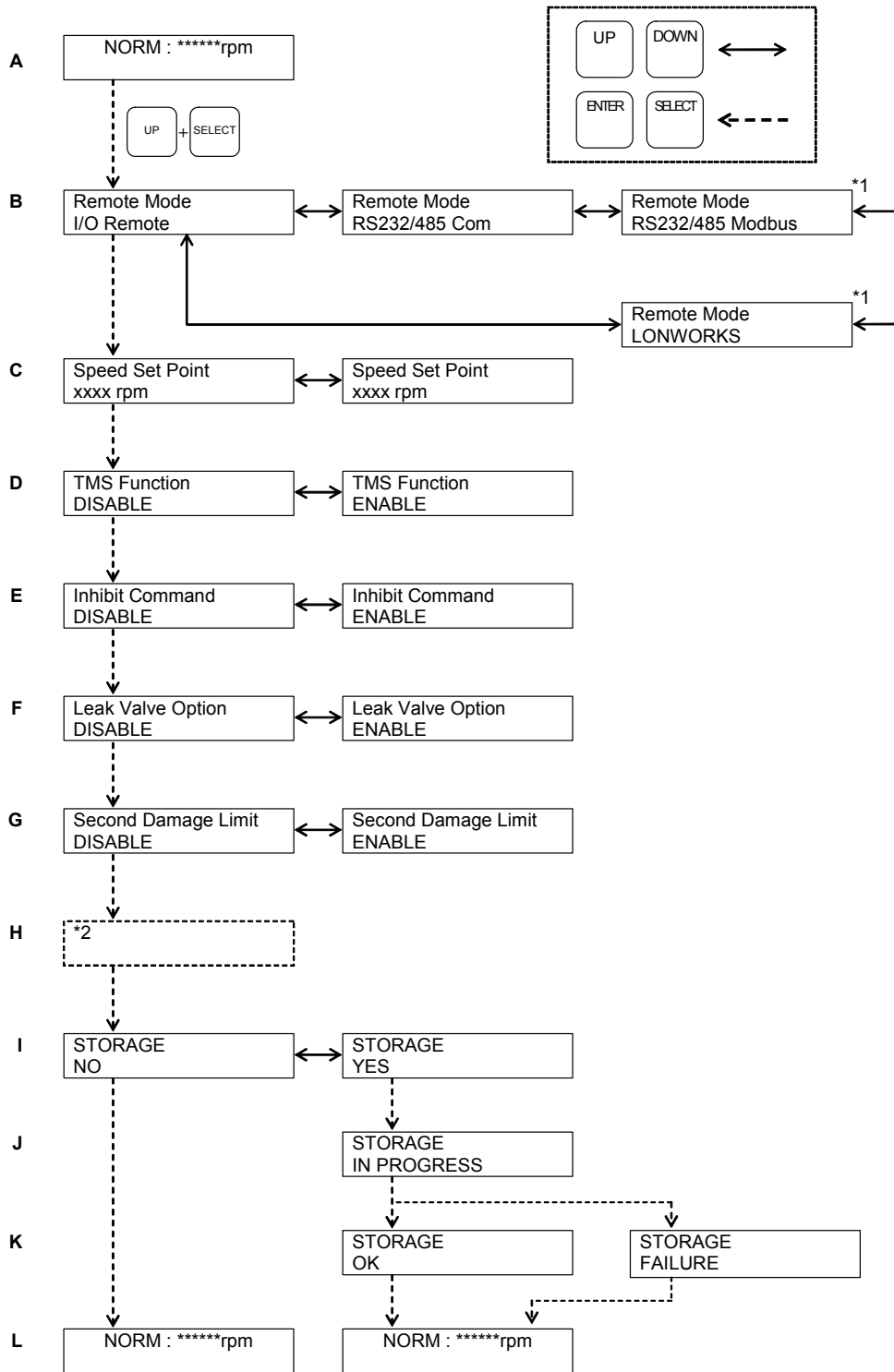

Figure 24 - Parameter setting method

SCU-750 Control Unit for Turbomolecular Pump

- A. Operation mode
- B. Remote mode setting
- C. Rated speed setting
- D. TMS function setting
- E. INHIBIT function setting
- F. Emergency vent valve setting
- G. Second damage limit setting
- H. Remote mode detail settings
- I. Save screen
- J. Saving
- K. Setting complete
- L. Operation mode

^{*1} DO NOT set the "RS232/485 Modbus" and "LONWORKS" settings of Remote mode because they cannot be set in the current configuration.

^{*2} Serial port detail settings. See Figure 23 for details. It is not displayed when "I/O Remote" setting.

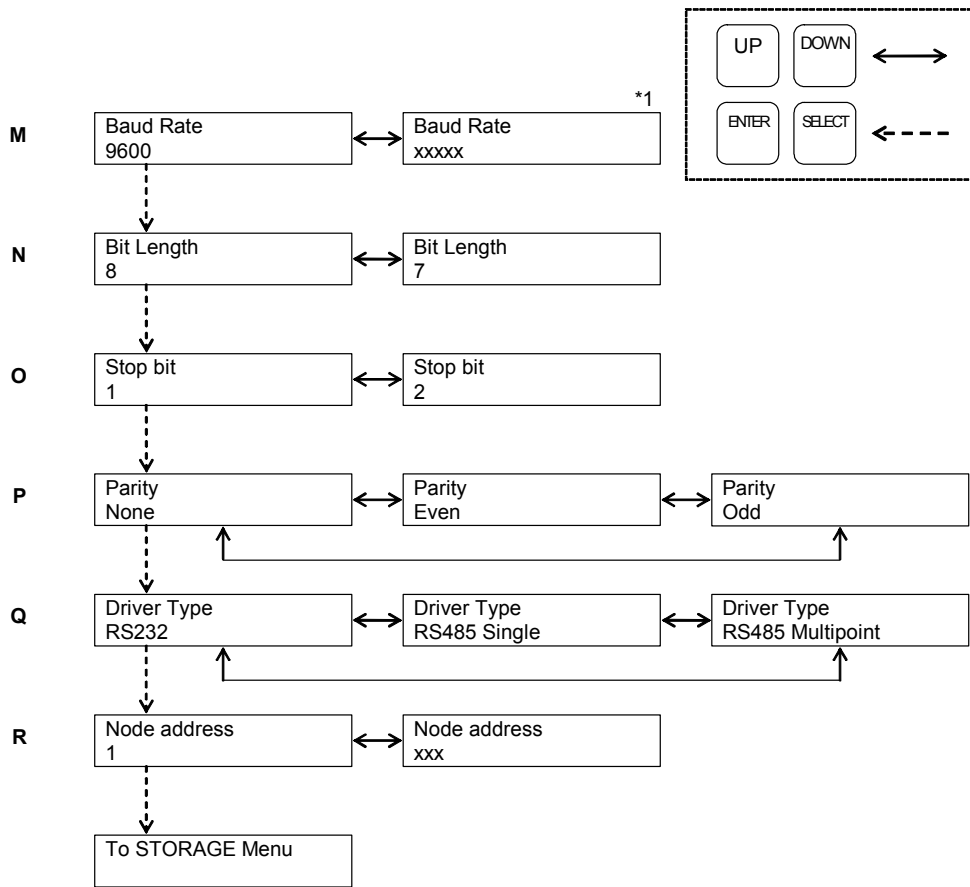

- M. Baud rate setting
- N. Bit length setting
- O. Stop bit setting
- P. Parity setting
- Q. Drive type setting
- R. Node address setting

^{*1} Available "Baud Rate" are 110, 300, 600, 1200, 2400, 4800, 9600 and 19200 bps. Available "Node address" is between 1 and 127.

Figure 25 - Parameter setting method (continued)

4 OPERATION

4.1 Before starting the STP pump

CAUTION

NEVER connect or disconnect any cables while the power is ON. NEVER turn the primary power OFF (turn the MAIN POWER "OFF") while the STP pump is in rotation. DO NOT release the inlet port flange or outlet port flange into the atmosphere while the STP pump is rotating

4.1.1 Confirmation before starting

After completing the installation of the STP pump and the SCU-750, carry out the following checks before starting:

1. Ensure the STP pump and the SCU-750 are installed correctly (refer to Section 3).
2. Ensure the correct supply voltage is applied.
3. Ensure all cables are securely connected and locked.
4. Ensure the length of the STP connection cable. If it is changed, perform the tuning according to Section 3.9.1, "Tuning".

4.1.2 Confirmation of vacuum system

1. Starting backing-pump

Start the backing-pump before or simultaneously with the start of the STP pump. Open the vacuum valve located at the outlet port flange side after starting the backing-pump.

Note: DO NOT open the vacuum valve without operating the backing-pump. Depending upon the type of the backing-pump, doing so may cause a reverse flow of oil, which could contaminate the inside of the STP pump.

2. Stop backing-pump

CAUTION

DO NOT stop the backing-pump without closing the vacuum valve. Depending upon the type of the backing-pump, doing so could cause a reverse flow of atmospheric air into the STP pump, which may result in a malfunction.

Close the vacuum valve located at the outlet port flange side just before or after stopping the STP pump. After closing the valve, stop the backing-pump.

Note: DO NOT stop the backing-pump without closing the vacuum valve. Depending upon the type of the backing-pump, doing so could cause a reverse flow of oil, which could contaminate the inside of the pump.

SCU-750 Control Unit for Turbomolecular Pump

4.2 Powering ON

4.2.1 Self test

Refer to Figure 26.

1. Switch the MAIN POWER to "ON", located on the SCU-750 rear panel, refer to Figure 11. (To prevent incorrect operation, a metal fitting is attached to the breaker. Loosen the screw, lift the metal fitting and secure it.) The SCU-750 performs a self test and "Autotest" is displayed on the LCD.
2. If no error is found, the LCD displays "Autotest complete" and the magnetic bearing is turned "ON". When the rotor levitates normally, the LCD displays "Levitation" and the STP pump can be operated.

4.2.2 "CAUTION" message in the self test state

When the configuration (the STP pump serial number or the SCU-750) is changed, a "CAUTION" message is displayed on the LCD during the self test. Refer to Table 27 when "CAUTION" is other than those in Table 7.

CAUTION message	Causes
New Serial Number	Connecting the same model but the different serial number of the STP pump to the SCU-750 after the tuning is performed.
New Pump Model	Connecting the different model of the STP pump to the SCU-750 after the tuning is performed.

Table 7 - Causes of "CAUTION" at the self test state

When "CAUTION : New Serial Number" or "CAUTION : New Pump Model" is displayed and "Re-tuning Necessary! Press RESET 5 sec." is alternately displayed, carry out the following:

1. Press the "RESET" switch for approximately 5 seconds.
2. When the LCD displays "Updating Data", release the "RESET" switch.
3. "Tuning" is displayed after a few seconds and tuning is performed automatically.
4. After completing the tuning, "Levitation" is displayed on the LCD and the rotating operation of the STP pump can be started.

4.3 How to Start/Stop the STP pump

There are two methods of operating the STP pump; MANUAL and REMOTE. Select one which suits your vacuum equipment.

4.4 Manual Start/Stop the STP pump

To manually Start/Stop the STP pump, slide the "MANUAL/REMOTE" changeover switch on the SCU-750 front panel from the "ON" position, refer to Figure 10. The "REMOTE" LED will extinguish.

4.4.1 Starting the STP pump

1. Press the "START" switch on the front panel to start, refer to Figure 10 and accelerate the STP pump. The "ACCEL." LED illuminates. The LCD displays the current rotational speed in "ACCEL: ***00rpm" in 500 rpm intervals. (ACCELERATION state)
2. When the STP pump attains the rated speed of rotation, the "ACCEL." LED extinguishes, and the "NORMAL" LED illuminates. The LCD displays "NORMAL: ***00rpm". (NORMAL OPERATION state)

4.4.2 Stopping the STP pump

1. Press the "STOP" switch on the front panel to stop the STP pump.
2. The "NORMAL" LED or "ACCEL." LED extinguishes, and the "BRAKE" LED illuminates. (BRAKE state)
3. When the rotational speed decreases to 500 rpm or less, the "BRAKE" LED extinguishes.

4.4.3 Starting the STP pump after stopping

1. Press the "START" switch on the front panel to accelerate the STP pump.
2. The STP pump can be accelerated even while it is stopping.

Note: Avoid frequent start/stop operations as this may cause the STP pump to overheat.

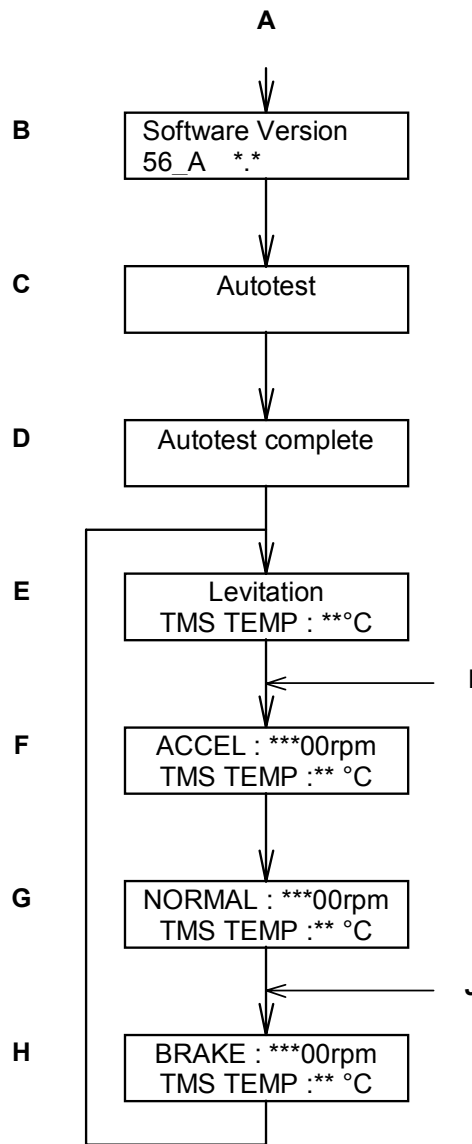

Figure 26 - Operational procedures

- | | | |
|-------------------------------------|--|--|
| A. MAIN POWER "ON" | E. Levitation State
Upper: Levitation state
Lower: TMS actual temp
(for only with TMS unit) | H. Break State
Upper: Brake state
Lower: TMS actual temp
(for only with TMS unit) |
| B. Version | F. Acceleration State
Upper: Acceleration state
Lower: TMS actual temp
(for only with TMS unit) | I. Start operation of the STP pump |
| C. Self test (upper only) | G. Normal Operation State
Upper: Normal operation state
Lower: TMS actual temp
(for only with TMS unit) | J. Stop operation of the STP pump |
| D. Self test completed (upper only) | | |

4.5 Remote operation

To select remote operation, slide the "MANUAL/REMOTE" changeover switch on the SCU-750 front panel to "ON", refer to Figure 10. The "REMOTE" LED illuminates.

4.5.1 Input signal pins

Use input signal pins according to Table 8 and Figure 27. Remote input signals are set to the parallel port in the remote setting and function during REMOTE operation only, expect pins for inputting the ROTATION INHIBIT.

Two abbreviations are used in Table 8 and Figure 27:

COM: Common Pin

IN: Input Pin





Pin	Description
	<p>Pins for inputting the START signal. The following two methods are available:</p> <ol style="list-style-type: none"> 1) Short the circuits between (1)-(21). Then, short the circuits between (3)-(21) for 0.3 seconds or more. However, when inputting this START signal simultaneously with switching "ON" the breaker on the rear panel, continue to short these pins for 10 seconds or more. 2) Short the circuits between (1)-(3). In this case, (21) is not used.
	<p>Pins for inputting the STOP signal.</p> <ol style="list-style-type: none"> 1) When 1) above is used to start the STP pump, open the circuits between (1)-(21) to stop the STP pump. 2) When 2) above is used to start the STP pump, open the circuits between (1)-(3) to stop the STP pump.
	<p>Pins for inputting the abnormality RESET signal.</p> <p>When a safety function operates, remove the cause of the abnormality/error after confirming the STP pump has stopped. When the cause of the abnormality/error is removed, short the circuits between (1)-(22) for 0.3 seconds or more to extinguish the "FAILURE" LED.</p>
	<p>Pins for inputting the rotation INHIBIT signal (valid in both MANUAL and REMOTE operations).</p> <p>When pins (1)-(5) are set to open, the STP pump does not rotate even by performing the start operation. (The pump does not rotate even by manually starting the pump) When these pins are set to open while the pump is in rotation, the pump will stop.</p> <p>When the INHIBIT signal is release, the pump restarts.</p> <p>When not using this function, set the rotation INHIBIT signal function to the "DISABLE" (see Section 3.11, "Parameter set mode").</p>
<p>(2), (4), (6), (18), (19), (20), (23), (24), (25), (31), (34) (36), (37)</p>	<p>These pins are not used.</p> <div style="text-align: center;"> <p>CAUTION</p> <p>DO NOT connect anything to these pins. Doing so may damage the SCU-750 or the vacuum equipment.</p> </div>

Table 8 - REMOTE X7 input signal pins

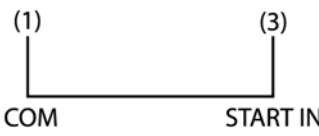

A. In case of Start 1) B. In case of Start 2) C. RESET signal D. Rotation INHIBIT signal E. Unused pins

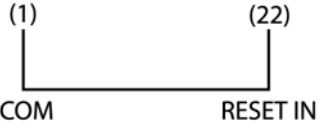
Figure 27 - REMOTE X7 input signal pins

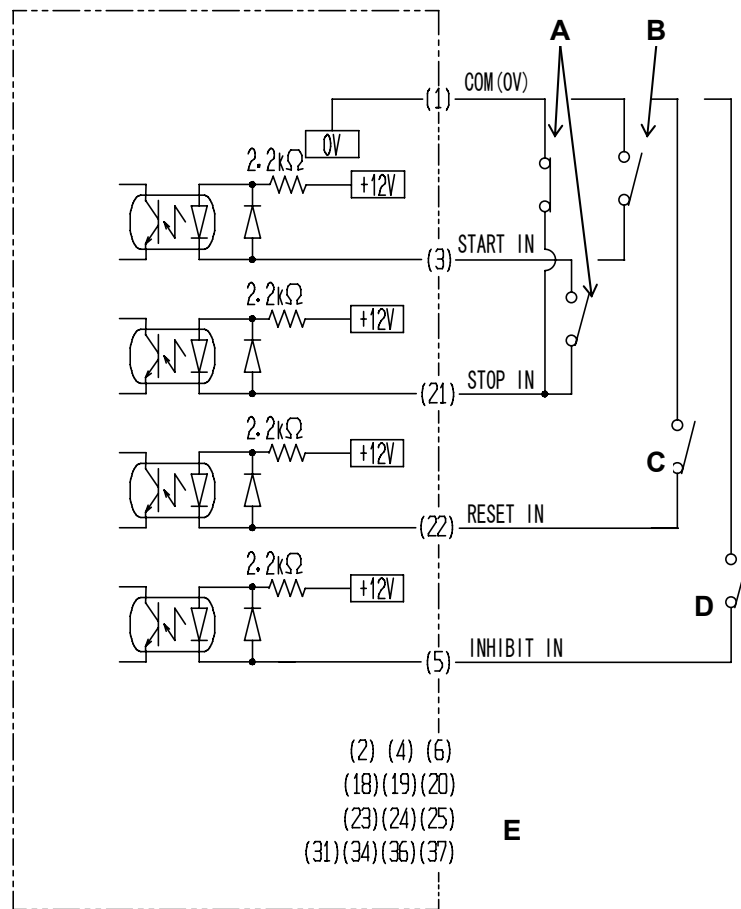
Note: 1 pin (0V) is insulated from the frame ground.

Note: The input current of remote input signal is approximately 5 mA. Make sure the minimum applicable load of the relay contact when the remote operation with the relay.

4.5.2 Output signal pins

Use output signal pins according to Table 9 and Figure 28. Remote output signals function during MANUAL and REMOTE operations. Three abbreviations are used in Table 9 and Figure 28.

- N.O OUT: Normal Open Output Pin
- N.C OUT: Normal Close Output Pin
- COM: Common Pin

Pin	Description
<p>(8) REMOTE N.O OUT (27)</p>	<p>Pins for outputting the STP pump REMOTE SELECTION state signal. When the MANUAL/REMOTE changeover switch on the front panel is set to ON (remote side), these pins are closed. ("REMOTE" operation)</p>
<p>(9) POWER N.O OUT (28)</p>	<p>Pins for outputting the POWER ON state signal. These pins are closed when magnetic bearing functions and the rotor levitates. This output is opened at a power failure.</p>
<p>(10) ACCELERATION N.O OUT (29)</p>	<p>Pins for outputting the ACCELERATION state signal. These pins are closed when the STP pump is in acceleration.</p>
<p>(11) N.O NORMAL OUT (30) (12) N.C COM</p>	<p>Pins for outputting the NORMAL OPERATION state signal. When the STP pump is in rated operation, the pins between (11)-(30) are closed, and the pins between (12)-(30) are opened.</p>
<p>(13) BRAKE N.O OUT (32)</p>	<p>Pins for outputting the BRAKE state signal. These pins are closed when the STP pump is in brake.</p>
<p>(14) N.O ALARM OUT (33) (15) N.C COM</p>	<p>Pins for outputting the ALARM signal. When an abnormality/error is detected under the POWER ON state, the pins between (14)-(33) are closed, and the pins between (15)-(33) are opened.</p>
<p>(16) N.O AT TEMP OUT (17) (35) N.C COM</p>	<p>Pins for the TMS unit rated state signal output. When the actual temperature of the TMS unit is within the setting temperature range $\pm 10^{\circ}\text{C}$, the pins between (16)-(17) are closed and the pins between (35)-(17) are opened.</p>
<p>(7) E.VALVE N.O OUT (26)</p>	<p>Pins for the emergency vent valve operation signal (Optional accessory). These pins are closed while this valve functions.</p>

Table 9 - REMOTE X7 output signal pins

SCU-750 Control Unit for Turbomolecular Pump

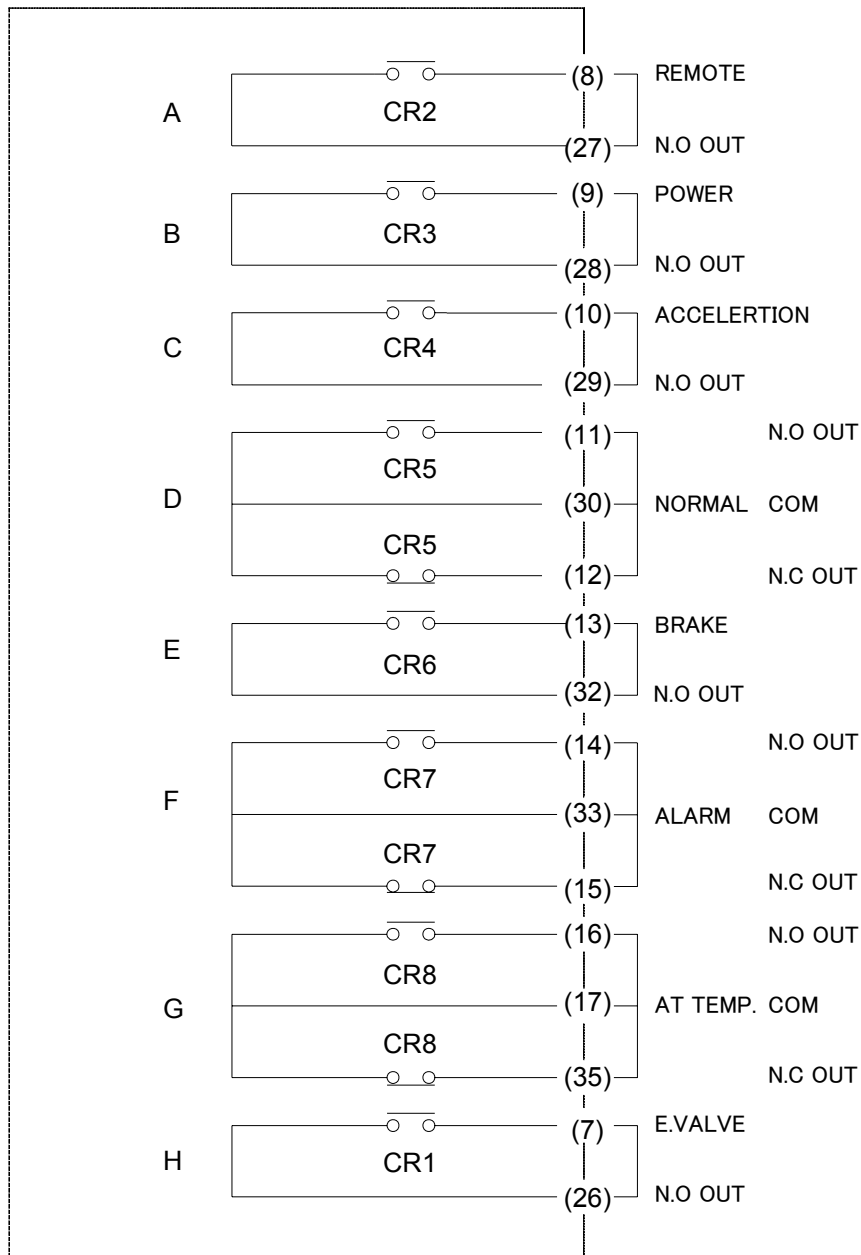

- | | |
|---|--|
| A. REMOTE selection state
signal output pins | E. BRAKE state
signal output pins |
| B. POWER ON state
signal output pins | F. ALARM state
signal output pins |
| C. ACCELERATION state
signal output pins | G. TMS unit rated state
signal output pins |
| D. NORMAL OPERATION
state signal output pins | H. Emergency vent valve
open signal output pins |

Figure 28 - REMOTE X7 output signal pins

SCU-750 Control Unit for Turbomolecular Pump

Table 10 shows the rated contacts for relays CR1 to CR8 in Figure 28.

	Resistance Load (COS Ø=1)
Rated Load	125 VAC, 0.5 A 24 VDC, 1 A
Rated Current	2A
Maximum Contact Point Current	1A
Maximum Open/Close Capacity	AC: 62.5 VA DC: 30 W
Minimum Applicable Load	5 VDC, 1 mA

Table 10 - Rated contacts for relays CR1 to CR8

4.5.3 Remote setting

The parallel port (REMOTE X7) and serial port (X3A/X3B) are fitted as standard. For the setting method of remote operation hardware, refer to Section 3.11.

This section details the operating method using the parallel port (REMOTE X7), refer to Figure 18, "X7 REMOTE connector" for details of pin location. For the operating method using the serial port, refer to Section 5.

4.5.4 Starting/Stopping the STP pump

There are two methods for the starting/stopping operation with the parallel port (REMOTE X7). Use one of them.

Method	Starting the pump	Stopping the pump
1	1) Short the circuit between (1)-(21). 2) Short the circuit between (3)-(21) for 0.3 seconds or more. However, when inputting this signal simultaneously with switching "ON" the breaker on the rear panel, short the circuit between (3)-(21) for 10 seconds or more.	Open the circuit between (1)-(21).
2	Short the circuit between (1)-(3). In this case, (21) is not used.	Open the circuit between (1)-(3).

Table 11 - Starting/Stopping the STP pump during remote operation (REMOTE X7)

4.5.5 Rotation INHIBIT signal

When using rotation INHIBIT signal, set the rotation INHIBIT function to the "ENALBE" according to Section 3.11, "Parameter set mode". Relations between rotation INHIBIT signal input and pump operation state are shown in Table 12.

Signal input	Pump operation
<p>After short-circuit of rotation INHIBIT input signal (A), the START operation is performed (B).</p>  <p>INHIBIT IN</p> <p>Open</p> <p>Close</p> <p>A B</p> <p>START operation</p>	<p><MANUAL/REMOTE operation mode></p> <ul style="list-style-type: none"> The pump accelerates when the START operation is performed (B).
<p>After the START operation (A), the rotation INHIBIT input signal is short-circuited (B).</p>  <p>INHIBIT IN</p> <p>Open</p> <p>Close</p> <p>A B</p> <p>START operation</p>	<p>< MANUAL operation mode ></p> <ul style="list-style-type: none"> The pump does not accelerate. <p>< REMOTE operation mode ></p> <ul style="list-style-type: none"> The pump does not accelerate when the START operation is performed (A). The pump accelerates when the rotation INHIBIT input signal is short-circuited (B).
<p>The rotation INHIBIT input signal is opened (A) during acceleration or normal operation.</p>  <p>INHIBIT IN</p> <p>Open</p> <p>Close</p> <p>A B</p> <p>START operation</p>	<p>< MANUAL/REMOTE operation mode ></p> <ul style="list-style-type: none"> The pump decelerates and stops when the rotation INHIBIT input signal is opened (A). After the operation (A), the pump continues deceleration and stops even by short-circuiting the rotation INHIBIT input signal (B). However, when the START signal is input, the pump will accelerate.

Table 12 - Rotation INHIBIT signal input

SCU-750 Control Unit for Turbomolecular Pump

4.5.6 Starting the STP pump after stopping

Perform the start operation to accelerate the STP pump. Refer to Section 4.5.4. The STP pump can be accelerated even while it is stopping.

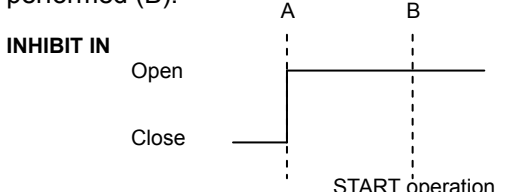
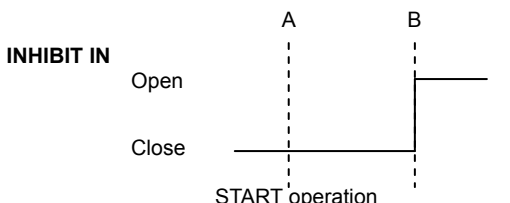
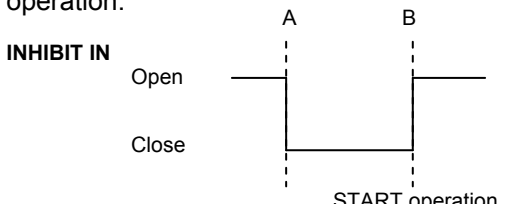
4.5.7 Starting the STP pump after a safety function operates

A safety function operates when an abnormality/error occurs in the STP pump or peripheral equipment. To restart the STP pump, remove the cause of the abnormality/error after the "BRAKE" LED extinguishes and perform the operation shown in Table 13. The "FAILURE" LED extinguishes and the safety function is released (RESET operation). Restart the STP pump. For the safety functions and troubleshooting, refer to Section 6.

Method	Reset Operation
1	Short the circuit between (1)-(22) for 0.3 seconds or more.

Table 13 - Reset operation during remote operation (REMOTE X7)

4.6 Powering OFF

Turn the MAIN POWER "OFF" on the SCU-750 rear panel when all three LEDs "ACCEL.", "NORMAL" and "BRAKE" extinguish. The magnetic bearing stops, the rotor stops, and the "POWER" LED extinguishes. (POWER OFF state)

SCU-750 Control Unit for Turbomolecular Pump

4.7 Operating the TMS unit (for use with the TMS unit)

4.7.1 Before starting

Check the following items before starting:

1. Check that the TMS connection cable is securely connected to the SCU-750.
2. Check that the TMS heater, the TMS valve, the cooling water pipe and the TMS sensor cable are securely connected.

Note: The STP-A1603 series of STP pump does not use the TMS sensor cable.

4.7.2 Starting/Stopping

Power on the STP pump to automatically start the TMS unit.

Power off the STP pump to automatically stop the TMS unit.

While the TMS unit is in operation, the "TEMP CTRL" LED illuminates on the SCU-750.

When STP pump is in the power ON state, the TMS unit operates regardless of the status of the SCU-750. When the STP pump is the cause of the malfunction, the TMS unit is stopped.

4.7.3 Setting the TMS unit function

When the "TEMP CTRL" LED does not illuminate on the SCU-750, after switching MAIN POWER "ON", the TMS function may be set to "DISABLE". Confirm and reset the TMS function according to Section 3.11.

4.7.4 Temperature control

When the temperature of the STP pump base is lower than the setting value, the TMS heater is turned "ON", and the TMS valve is turned "OFF" to heat the STP pump. When the temperature of the STP pump base is higher than the setting value, the TMS heater is turned "OFF", and the TMS valve is turned "ON" to cool the STP pump. The LCD displays the actual temperature of the STP pump base as "TMS TEMP: ** °C".



SCU-750 Control Unit for Turbomolecular Pump

4

OPERATION

This page intentionally blank.

5 SERIAL COMMUNICATION PROTOCOL

5.1 Introduction

The SCU-750 is provided with compliant serial interface. Prepare the user application software according to this instruction manual. Operation instructions and information, such as the running state and setting values of the STP pump (information which appears on the LCD of the SCU-750) can be obtained with the software.

The serial ports located on the SCU-750 rear panel are called Serial Interface Module (SIM). Refer to Figure 29.

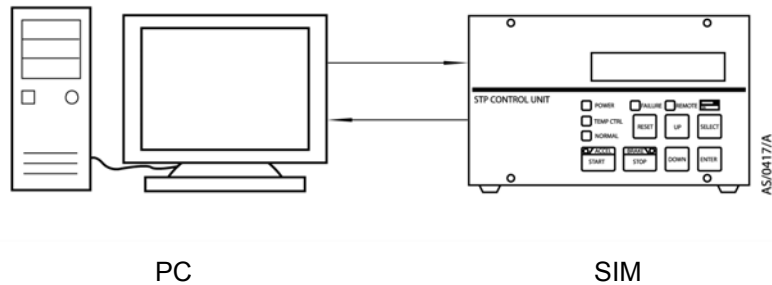

Figure 29 - Serial communication

5.2 Connection and setting up

5.2.1 Signal connection

Connect the PC serial port to connectors X3A or X3B (a D-Sub9-pin, socket) on the rear panel (refer to Figure 11). Connect only TxD/RxD/GND in the RS232 and D+/D- in the RS485 in accordance with Table 14 and Figure 30. DO NOT connect other pins which are reserved as optional use.

	X3A (D-Sub9 pin, socket)	X3B (D-Sub9 pin, socket)
RS232	2 (TxD)	-
	3 (RxD)	-
	5 (GND)	-
RS485	7 (D-)	7 (D-)
	8 (D+)	8 (D+)
Reserved	1, 4, 6, 9	1, 2, 3, 4, 5, 6, 9

Table 14 - X3A/X3B pin position

SCU-750 Control Unit for Turbomolecular Pump

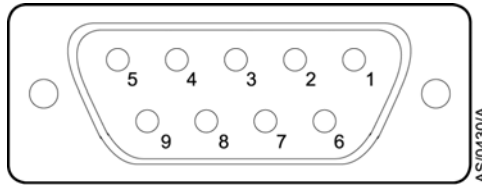

Figure 30 - Serial port connector

Note: The connectors X3A and X3B are fitted using M2.6 screws.

RS232 and RS485 cannot be used at the same time. The factory setting is RS232. When connecting RS485, the change of communication parameter setting is required, refer to Section 3.11.

When connecting RS232, the length of the communication cable should be 15 m or less. When connecting RS485, refer to Section 5.2.2.

5.2.2 Connecting the RS485

Make sure the followings when using the serial port COM1 (connector X3A or X3B) with RS485.

A connection condition is 1 on 1 (single point connection) or 1 on N (multi-point connection).
 A maximum number of 32 SIMs are connectable in the multi-point connection.

Use twisted-pair wire in communication cable. The extended communication cables should be 1.2 km or less.

Connect the terminator to the communication devices at both ends of the transmission line. The terminator (120 Ω, 0.25 W) is required for connection.
 (the SCU-750 dose not have terminator setting function)

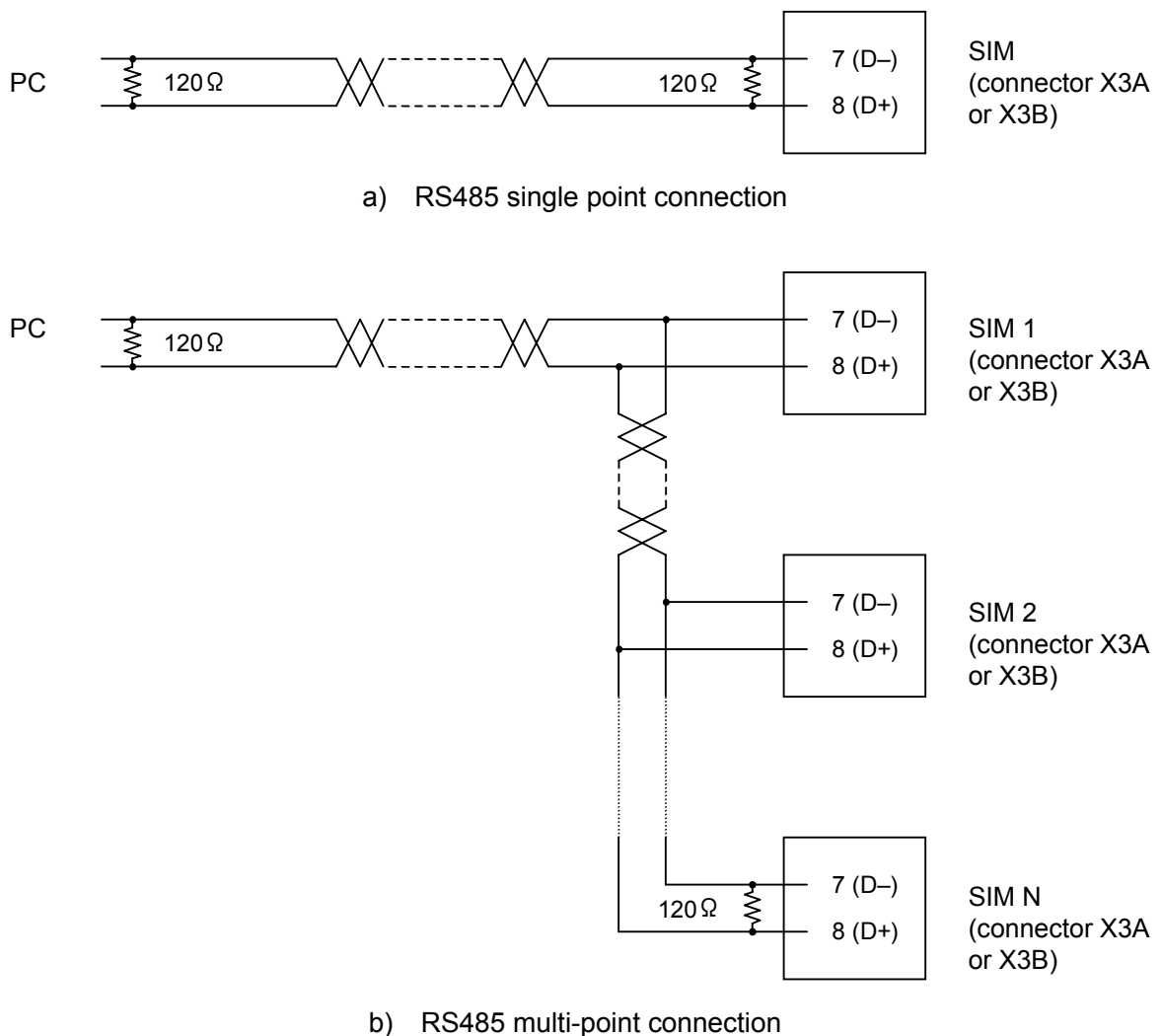

Figure 31 - RS485 connections

SCU-750 Control Unit for Turbomolecular Pump

5.2.3 Communication parameter setting

The factory setting of the communication parameter is shown in Table 15. When changing the communication parameter, refer to Section 3.11, "Parameter set mode".

To use the operational commands of the SCU-750 (START, STOP, RESET), set the MANUAL/REMOTE changeover switch on the SCU-750 to "ON", and set the Remote mode to "RS232/RS485 Com", refer to Figure 10.

Communication parameter	Factory Setting	Setting range
Remote mode	I/O Remote	I/O Remote, RS232/RS485 Com
Baud rate	9,600 bps	110 to 19,200 bps
Bit length	8 bit	7, 8 bit
Stop bit	1 bit	1, 2 bit
Parity	None	None, Even, Odd
Driver type	RS232	RS232, RS485 single, RS485 multipoint
Node Address ^{*1}	1	1 to 127

*1 This value is used with "RS485 multipoint".

Table 15 - Communication parameters

5.3 Protocol specifications

5.3.1 General description

The STP serial communication protocol enables the SIM to receive the communication command (Figure 32, item 1), transmitted from the PC and send a response (Figure 32, item 2), following the communication command. Each communication command from the PC transmits a text message (ASCII text) assigned to each function. Communication commands include control commands (STP pump operation commands, and so forth) and query commands (read-out of STP pump operation mode, and so forth).

SCU-750 Control Unit for Turbomolecular Pump

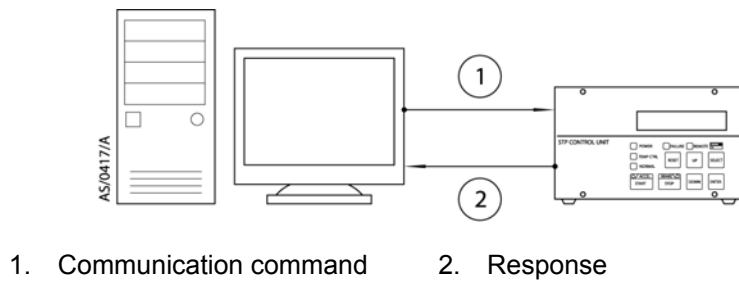

Figure 32 - PC to SIM communication

Table 16 shows ASCII characters being used in the transmission control, error control and handshake in the application layer. Note that the transmission frame form differs depending upon the RS232/RS485 single port connection and RS485 multi-port connection. (refer to Section 5.3.8)

	ASCII character	HEX code	Function
Transmission layer	Stx	02	Transmission block start character
	Etx	03	Transmission frame end character
	Etb	17	Transmission block end character
	Ack	06	Acknowledgment response
	Nak	15	Non-acknowledgment response
	@	40	Network frame ID character
Application layer	#	23	Acknowledgment response
	!	21	Non-acknowledgment response

Table 16 - Transmission control characters

5.3.2 Standard transmission frame (in the RS232/RS485 single port connection)

The transmission frame used in the RS232/RS485 single port connection has a single block or multiple transmission blocks. The transmission block consists of a start control character, data block number (3 digits), a message (up to 255 characters), an end control character and a checksum (Longitudinal Redundancy Check (LRC)). The following table shows the transmission frame where the message transmission character string is C_n .

Transmission frame when a message is below 255 characters ($n \leq 255$):

	1	2	3	4	5		5+n	5+n+1	5+n+2
ASCII	Stx	0	0	1	C_1		C_n	Etx	LRC

"Stx" and "Etx" are used as a start and an end character of the transmission frame, respectively.

SCU-750 Control Unit for Turbomolecular Pump

Transmission frame when a message exceeds 255 characters ($n = 255$, $m \leq 255$, $k =$ the number of transmission blocks):

First		1	2	3	4	5			5+n	5+n+1	5+n+2
Block	ASCII	Stx	0	0	1	C ₁			C ₁ _n	Etb	LRC
Second		1	2	3	4	5			5+n	5+n+1	5+n+2
Block	ASCII	Stx	0	0	2	C ₂			C ₂ _n	Etb	LRC
Final		1	2	3	4	5			5+m	5+m+1	5+m+2
Block	ASCII	Stx	k			C _k			C _k _m	Et _x	LRC

"Stx" is used as a start character of each transmission block; "Etb" is used as an end character of the transmission block with a message of 255 characters; "Et_x" is used as an end character of the final transmission block (the end character of the transmission frame).

5.3.3 Control command (in the RS232/RS485 single port connection)

A control command is used when transmitting a pump operation command and a setting change command to the SIM. The first character of the control command in the RS232/RS485 single port connection is "Bsp" (a space character, HEX code "20") and succeeding characters are ASCII characters corresponding to the respective function code and parameter.

Bsp	CHR	C ₁	C ₂					C _n
-----	-----	----------------	----------------	--	--	--	--	----------------

CHR: Function code character, C₁ to C_n: Parameter.

Parameter (from C₁ to C_n) serves as 16 bits signed hexadecimal value coded ASCII text. When a message (a space character, a function code, and parameter) exceeds 255 characters, input "Bsp" and CHR to the top transmission block only (the first transmission block of the transmission frame). It is not necessary to input them to the second and succeeding transmission blocks.

The SIM returns the acknowledgment response character "#" when the control command is processed normally. If not, the SIM returns the non-acknowledgment response character "!" and 3 characters of the non-acknowledgment code are added to "!".

Transmission frame when data is transmitted to one block (a message is less than 256 characters):

Designate the control command on the PC.

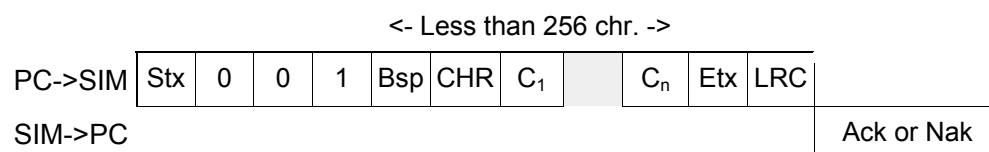

Always assign less than 254 characters ($n < 254$) to the parameter so that the message is less than 256 characters.

SCU-750 Control Unit for Turbomolecular Pump

Then the preceding SIM->PC character is "Ack", the instructed control command is executed and the SIM returns the following response.

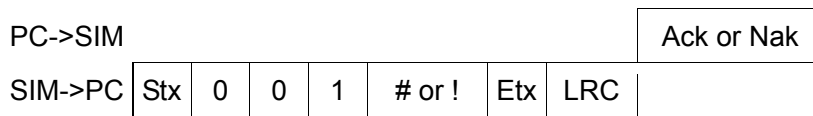

The PC transmits "Ack" or "Nak"; then transmits the next command if necessary.

Transmission frame when data is transmitted to two blocks (message is more than 256 characters and less than 512 characters):

Designate the control command (the 1st block) on the PC

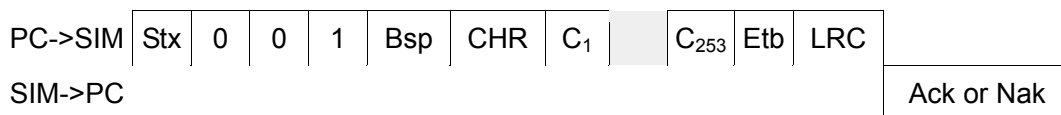

Next, the preceding SIM->PC character is "Ack", the PC continues instructing the control command (the 2nd block).

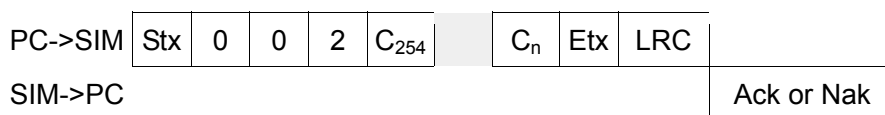

Always assign less than 510 characters ($n < 510$) to the parameter so that the message is less than 512 characters.

Then the preceding SIM->PC character is "Ack", the instructed control command is executed and the SIM returns the following response.

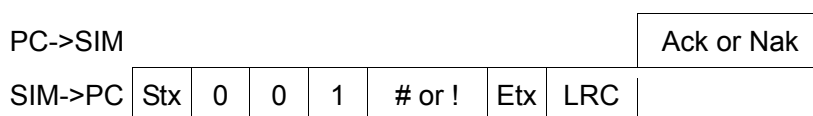

The PC transmits "Ack" or "Nak"; then transmits the next command if necessary.

5.3.4 Query command (in the RS232/RS485 single port connection)

A query command is used to read the pump operation state and setting values. The first character of the query command in the RS232/RS485 single port connection is "?" (HEX code "3F"), and succeeding characters are ASCII characters corresponding to the respective function code and parameter.

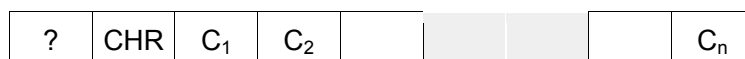

CHR: Function code character, C₁ to C_n: Parameter

SCU-750 Control Unit for Turbomolecular Pump

Parameter (from C₁ to C_n) serves as 16 bits signed hexadecimal value coded ASCII text. When a message (a space character, a function code, and parameter) exceeds 255 characters, input "?" and CHR to the top transmission block only (the first transmission block of the transmission frame). It is not necessary to input them to the 2nd and succeeding transmission blocks.

The SIM returns the answer characters when the query command is processed normally. If not, the SIM returns the non-acknowledgment response character "!" and 3 characters of the non-acknowledgment code are added to "!".

Transmission frame when data is transmitted at one block and returned at two blocks:

Designate a query command on the PC

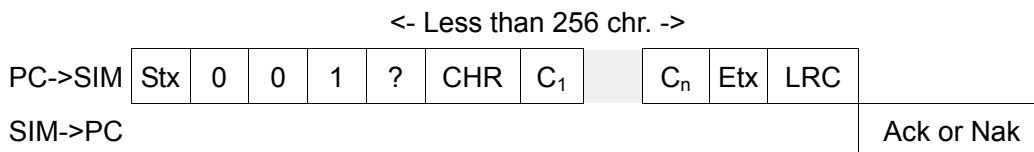

Always assign less than 254 characters (n < 254) to the parameter so that the message is less than 256 characters.

Next, the preceding SIM->PC character is "Ack", the instructed query command is executed and the SIM returns the following response (1st block).

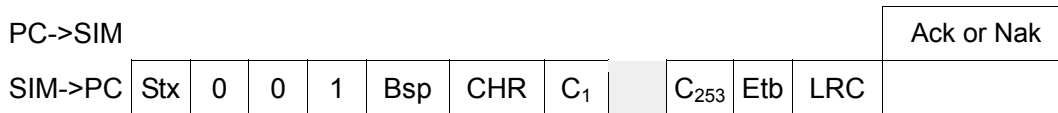

Then "Ack" is sent by the SIM->PC character in reaction to the response (1st block) from the SIM, the SIM returns the following response (2nd block).

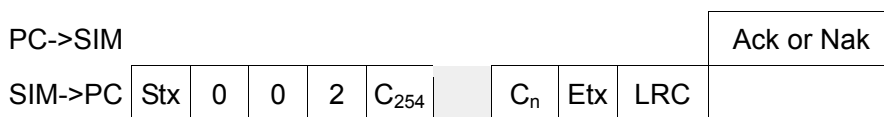

The PC transmits "Ack" or "Nak"; then transmits the next command if necessary.

5.3.5 Transmission data format

Data value is always 16 bits signed hexadecimal value coded ASCII text.

Example: 12090 on a decimal basis equals to 2F3A on a hexadecimal basis.

5.3.6 Frame control (Checksum)

The transmission frame is controlled by the odd number parity check. First initialize LRC as FF_{hex}. Next calculate LRC by EXCLUSIVE-OR (XOR) of all the frame bytes containing "Stx", "Etb", "Etx" and LRC and transmit the result as LRC.

Examples:

Character string for calculation before calculating LRC.

ASCII	Stx	0	0	1	#	Etx	LRC
HEX	02	30	30	31	23	03	FF

Calculation of LRC:

$$02_{\text{hex}} \text{ XOR } 30_{\text{hex}} \text{ XOR } 30_{\text{hex}} \text{ XOR } 31_{\text{hex}} \text{ XOR } 23_{\text{hex}} \text{ XOR } 03_{\text{hex}} \text{ XOR } FF_{\text{hex}} = EC_{\text{hex}}$$

Character string for transmission after calculating LRC.

ASCII	Stx	0	0	1	#	Etx	LRC
HEX	02	30	30	31	23	03	EC

5.3.7 Error control

- Transmit the transmission frame repeatedly from the PC when the SIM transmits "Nak" (parity check error). When the SIM receives "Nak" from the PC, the transmission frame is transmitted again. This operation is repeated up to 5 times.
- The SIM transmits "Ack" or "Nak" to the PC after the completion of communication command reception. When the PC cannot receive "Ack" or "Nak" after 2 second, retransmit the transmission frame from the PC.

When these communication statuses occur repeatedly, display to an error message or start the error routine on the PC.

5.3.8 Transmission frame in the RS485 multi-port connection

To identify a network frame and ensure the compatibility with a standard transmission frame, add a network frame ID character "@" and a title of 3 characters of network frame number to the transmission frame in the RS485 multi-port connection.

The network frame number is specified by any 16 bits signed hexadecimal value coded ASCII text of 1 to 127, to identify the SIM.

SCU-750 Control Unit for Turbomolecular Pump

Examples: Network frame ID character and number in the multi-port connection

ASCII	@	0	1	Network frame No "1"
HEX	40	30	31	

ASCII	@	6	4	Network frame No "100"
HEX	40	36	34	

ASCII	@	7	F	Network frame No "127"
HEX	40	37	46	

The transmission frame has a single block or multiple transmission blocks. Each transmission block consists of a network frame ID character, a network frame number, a start control character, data block number (3 digits), a message (up to 255 characters), an end control character and a checksum (LRC). The following shows the transmission frame when the message transmission character string is C_n .

Transmission frame when a message is below 255 characters ($n \leq 255$):

	1	2	3	4	5	6	7	8		8+n	8+n+1	8+n+2
ASCII	@	F ₁	F ₂	Stx	0	0	1	C ₁		C _n	Et _x	LRC

"@" is used as a network frame ID character.

"Stx" and "Et_x" are used as a start and an end character of the transmission frame, respectively.

Transmission frame when a message exceeds 255 characters ($n = 255$, $m \leq 255$, $k =$ the number of transmission blocks)

First		1	2	3	4	5	6	7	8		8+n	8+n+1	8+n+2
Block	ASCII	@	F ₁	F ₂	Stx	0	0	1	C _{1₁}		C _{1_n}	Et _b	LRC

Second		1	2	3	4	5	6	7	8		8+n	8+n+1	8+n+2
Block	ASCII	@	F ₁	F ₂	Stx	0	0	2	C _{2₁}		C _{2_n}	Et _b	LRC

Final		1	2	3	4	5	6	7	8		8+m	8+m+1	8+m+2
Block	ASCII	@	F ₁	F ₂	Stx	k			C _{k₁}		C _{k_m}	Et _x	LRC

"@" is used as a network frame ID character.

"Stx" is a start character of each transmission block, and "Et_b" is an end character of the transmission block of a message of 255 characters.

"Et_x" is used as an end character of the final transmission block (end character of the transmission frame).

5.3.9 Control command in the RS485 multi-port connection

The control command to be used when a pump operation instruction or a setting change instruction is transmitted to the SIM and is arranged in the order specified below. The top is "Bsp" (space character, HEX code "20") and ASCII characters corresponding to the respective function code and parameter follow.



CHR: Function code character, C₁ to C_n: Parameter

Parameter (from C₁ to C_n) serves as 16 bits signed hexadecimal value coded ASCII text. When a message (a space character, a function code, and parameter) exceeds 255 characters, input "Bsp" and CHR to the top transmission block only (the first transmission block of the transmission frame). It is not necessary to input them to the second and succeeding transmission blocks.

The SIM returns the acknowledgment response character "#" when the control command is processed normally. If not, the SIM returns the non-acknowledgment response character "!" and 3 characters of the non-acknowledgment code are added to "!".

Transmission frame when data is transmitted to one block (a message is less than 256 characters):

Designate the control command on the PC.

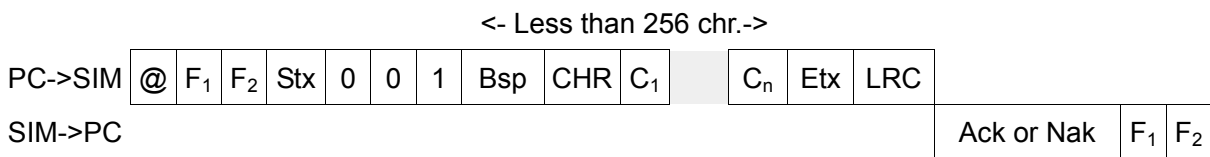

Always assign less than 254 characters (n < 254) to the parameter so that the message is less than 256 characters.

Next, the preceding SIM->PC character is "Ack," the instructed control command is executed and the SIM returns the following response.

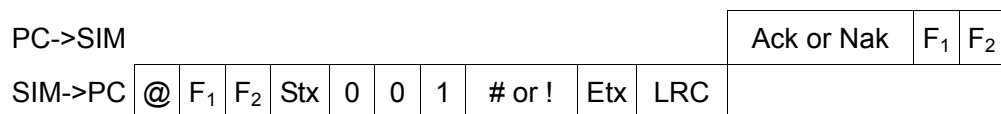

The PC transmits "Ack" or "Nak"; then transmits the next command if necessary.

Transmission frame when data is transmitted to two blocks (message is more than 256 characters and less than 512 characters):

Designate the control command (the 1st block) on the PC.

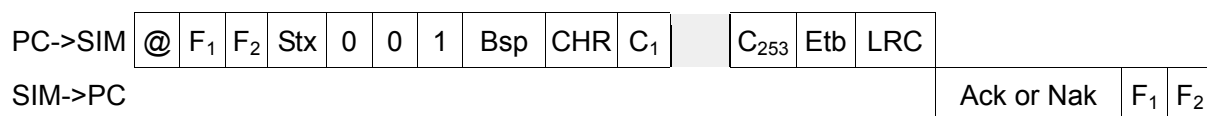

SCU-750 Control Unit for Turbomolecular Pump

Next, the preceding SIM->PC character is "Ack", the PC continues instructing the control command (the 2nd block).

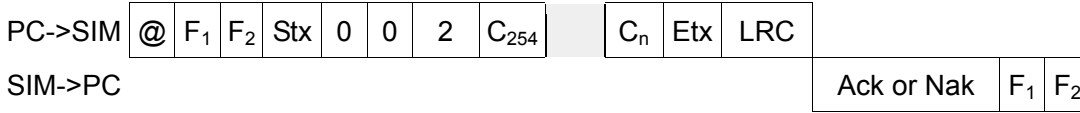

Always assign less than 510 characters (n< 510) to the parameter so that the message is less than 512 characters.

Then the preceding SIM->PC character is "Ack", the instructed control command is executed and the SIM returns the following response.

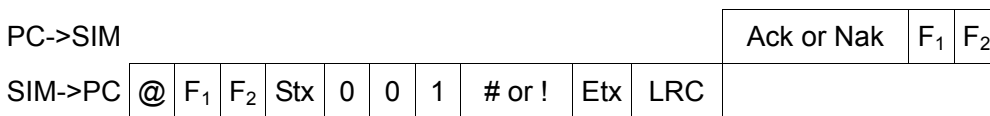

The PC transmits "Ack" or "Nak"; then transmits the next command if necessary.

5.3.10 Query command in the RS485 multi-port connection

The query command to be used when a pump operation instruction or a setting change instruction is transmitted from the SIM and is arranged in the order specified below. The top is "?" (HEX code "3F") and ASCII characters corresponding to the respective function code and parameter follow.

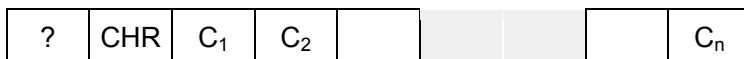

CHR: Function code character, C₁ to C_n: Parameter.

Parameter (from C₁ to C_n) serves as 16 bits signed hexadecimal value coded ASCII text. When a message (a space character, a function code, and parameter) exceeds 255 characters, input "?" and CHR to the top transmission block only (the first transmission block of the transmission frame). It is not necessary to input them to the second and succeeding transmission blocks.

The SIM returns the answer characters when the query command is processed normally. If not, the SIM returns the non-acknowledgment response character "!" and 3 characters of the non-acknowledgment code are added to "!".

Transmission frame when data is transmitted from one block and returned to two block.

Designate a query command on the PC.

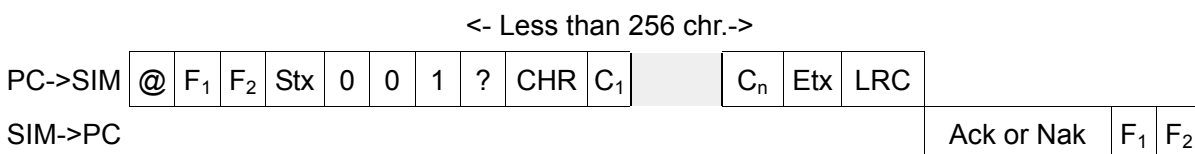

SCU-750 Control Unit for Turbomolecular Pump

Always assign less than 254 characters (n < 254) to the parameter so that the message is less than 256 characters.

Next, the preceding SIM->PC character is "Ack", the instructed query command is executed and the SIM returns the following response (1st block).

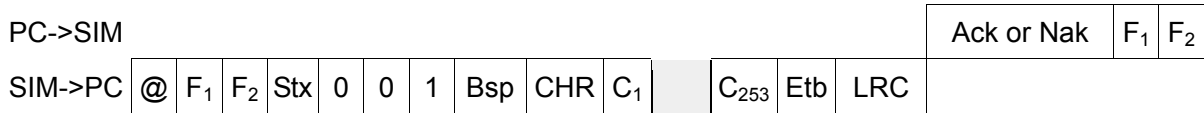

Then "Ack" is sent by the SIM->PC character in reaction to the response (1st block) from the SIM, the SIM returns the following response (2nd block).

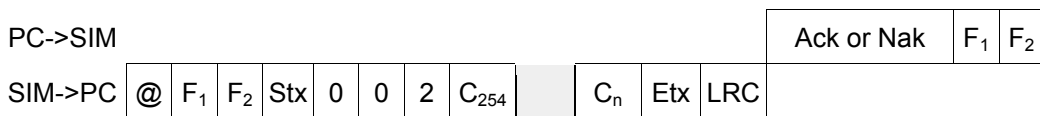

The PC transmits "Ack" or "Nak"; then transmits the next command if necessary.

5.3.11 Broadcasting command in the RS485 multi-port connection

The START or STOP of STP pump operation command can be concurrently instructed to all the multi-connected SIMs. Always assign 0 (HEX code "30", "30") to network frame number. Note that there is no response from the respective SIM.

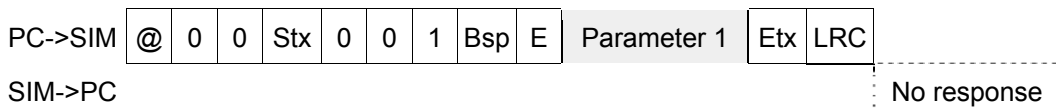

Parameter	Item	Data Format	Remark
1	Pump operation command	8-bits hexadecimal coded ASCII	Refer to Table 17

Pump operation command	Value
START	1
STOP	2

Table 17 - Pump operation commands

5.4 Command specifications

5.4.1 Command list

Function code		Command/Query Name	Function
?	D	ReadMeas	Reads the measured rotational speed.
Bsp	E	Command	Sends commands START, STOP, RESET (valid when MANUAL/REMOTE switch is selected ON.)
?	F	ReadFailMess	Reads the errors being detected.
?	M	ReadModFonct	Reads the pump operation mode and the errors being detected.
?	V	ReadVersion	Reads the software version of the SCU-750.
?	c	ReadCounters	Reads serial number, hour counter and start counter.
?	d	ReadSetPoint	Reads the setting values of the speed set point and the TMS temperature.
?	e	ReadMotorTemp	Reads the measured motor temperature.
?	f	ReadStatus	Reads the various settings. (Remote mode, TMS function, INHIBIT and emergency vent valve).
?	g	ReadEvents	Reads the error record.
Bsp	h	SetSpeedSetPoint	Changes the speed set point.
?	h	ReadSpeedSetPoint	Reads the speed set point.
?	[ReadMeasValue	Reads the TMS temperature, motor temperature and measured rotational speed.

Table 18 - Command list

5.4.2 ReadMeas

Function: Reads the measured rotational speed.

Transmission frame:

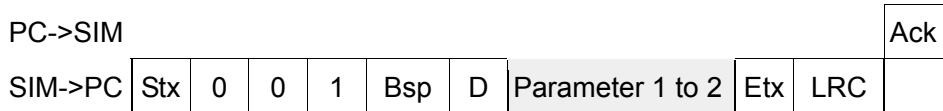
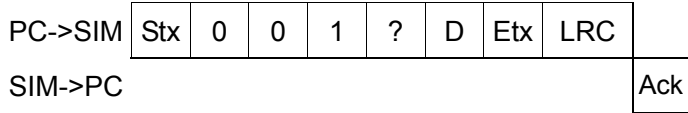

Parameter	Item	Data format	Remark
1	[System reservation]	56-bits hexadecimal coded ASCII	
2	Measured rotational speed (Unit: Hz)	16-bits hexadecimal coded ASCII	

Example:

Measured rotational speed: 02DC_{hex} = 732 Hz = 43,920 rpm

Parameter	1												2				
ASCII	*1	*1	*1	*1	*1	*1	*1	*1	*1	*1	*1	*1	*1	0	2	D	C
HEX														30	32	44	43

*1 System reservation

5.4.3 Command

Function: Sends the pump operation commands START, STOP and RESET. These commands function in the same way as when each switch of the SCU-750 is pressed. They are valid only when MANUAL/REMOTE changeover switch on the SCU-750 is "ON".

Transmission frame:

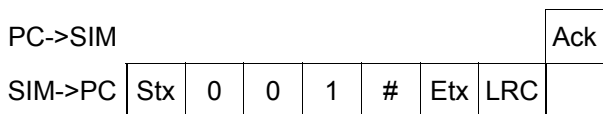
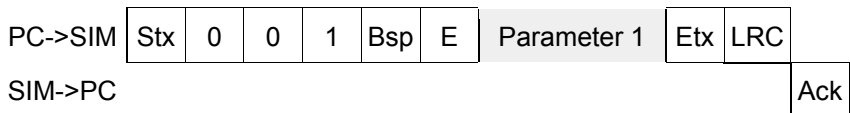

Parameter	Item	Data format	Remark
1	Pump operation command	8-bits hexadecimal coded ASCII	Refer to Table 19

Pump operation command	Value
START	1
STOP	2
RESET	4

Table 19 - Pump operation commands

Example:

Pump operation command: RESET operation = 4 = 04_{hex}

Parameter	1	
ASCII	0	4
HEX	30	34

5.4.4 ReadFailMess

Function: Reads the errors being detected. This data is the same data as that of "ReadModFonct" parameter 2 to 34.

Transmission frame:

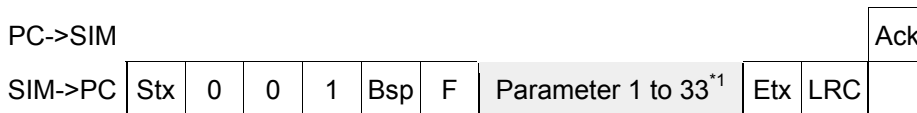
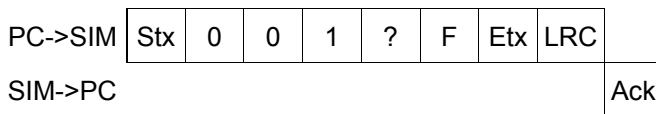

SCU-750 Control Unit for Turbomolecular Pump

Parameter	Item	Data format	Remark
1	The number of error	8-bits hexadecimal coded ASCII	Up to 32 errors ^{*1}
2 to 33 ^{*1}	Error 1	8-bits hexadecimal coded ASCII	^{*2}
	
	Error 32 ^{*1}	8-bits hexadecimal coded ASCII	

^{*1} The maximum number of errors may differ depending upon the software version of SCU-750. It is recommended that an application is designed as variable-length data.

^{*2} Value corresponding to the error message is transmitted, (refer to Table 20). The most recent error has the largest parameter number. When the number of errors being detected is under the maximum number, the value of parameter that is larger than the number of errors being detected is set to 0.

Example:

- The number of error : 02_{hex} = 2 errors
- Error 1 : 0D_{hex} = 13 = Disturbance Xh
- Error 2 : 0F_{hex} = 15 = Disturbance Xb
- Error 3 to 32 : 00_{hex} = No error detected

Parameter	1	2	3	4	5	6	7	8	9	10
ASCII	0 2	0 D	0 F	0 0	0 0	0 0	0 0	0 0	0 0	0 0
HEX	30 32	30 44	30 46	30 30	30 30	30 30	30 30	30 30	30 30	30 30

Parameter	11	12	13	[Omitted]					
ASCII	0 0	0 0	0 0	28	29	30	31	32	33
HEX	30 30	30 30	30 30	0 0	0 0	0 0	0 0	0 0	0 0
	30 30	30 30	30 30	30 30	30 30	30 30	30 30	30 30	30 30

SCU-750 Control Unit for Turbomolecular Pump

Error message	Value	Error message	Value
Ram error	0	DSP->PCB Com Fail	33
Eeprom Error	1	PCB->DSP Com Fail	34
TMS Higher Temp	2	TMS Sensor Lost	35
TMS Breaker Trip	3	Tuning Error 1	36
TMS Overheat	4	Tuning Error 2	37
Mains Failure	5	Tuning Error 3	38
Power Supply Failure	6	Tuning Error 4	39
Overspeed 1	7	Tuning Error 5	40
Driver Overvoltage	8	ATMP Failure	41
CAUTION: CNT heat 1	9*	RTMP Failure	42
CNT Overheat 1	10	CAUTION X_H	43*
Driver Overcurrent	11	CAUTION X_B	44*
Driver Overload	12	CAUTION Z	45*
Disturbance X_H	13	Tuning Error 6	46
Disturbance Y_H	14	Tuning Error 7	47
Disturbance X_B	15	Tuning Error 8	48
Disturbance Y_B	16	Tuning Error 9	49
Disturbance Z	17	Driver Failure	50
Motor Overheat	18	R-Unit Failure	51
CAUTION: CNT Heat 2	19*	Motor Resistor Lost	52
CNT Overheat 2	20	Driver PWM Trouble	53
T.Cable Disconnected	21	Driver FAN Failure	54
P.Cable Disconnected	22	Driver CPU Error	55
E.Valve Disconnect	23	R-Unit Com. Failure	56
Driver Com. Failure	24	Amp Overcurrent	57
First Damage Limit	25*	DSP Initialize Fail	58
Second Damage Limit	26	Accel Malfunction	59
START NOT ALLOWED	27	Pump Record Failure	60
Speed Pulse Lost	28	PCB Record Failure	61
Overspeed 2	29	Tuning Error 10	62
Overspeed 3	30	Tuning Error 11	63
M_Temp Sensor Lost	31	Tuning Error 12	64
TMS Lower temp	32	Tuning Error 13	65

Table 20 - Error message values

Error message	Value
Tuning Error 14	66
Tuning Error 15	67
Tuning Error 16	68
Tuning Error 17	69
Tuning Error 18	70
Tuning Error 19	71

Error message	Value
Aberrant Brake	72
Aberrant Accel	73
TMS Voltage Mismatch	74
Insufficient Supply	75
Inordinate Current	76

Table 21 - Error message values (continued)

* CAUTION or WARNING message. It is not a state of failure. Refer to Section 6 for details. The STP pump will continue to operate after one of these messages is displayed. It is recommended that an application be designed with this in consideration.

5.4.5 ReadModFonct

Function: Reads the pump operation mode and the errors being detected. The data of errors being detected reads the same data as that of "ReadFailMess".

Transmission frame:

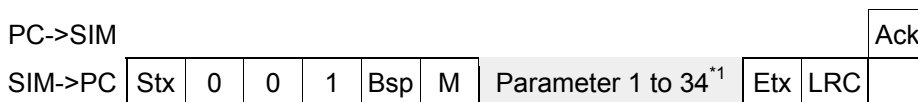
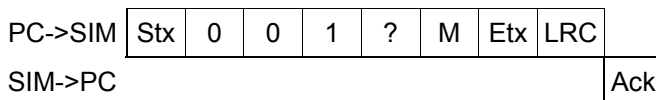

Parameter	Item	Data format	Remark
1	Pump operation mode	8-bits hexadecimal coded ASCII	Refer to Table 21
2	The number of error	8-bits hexadecimal coded ASCII	Up to 32 errors ^{*1}
3 to 34 ^{*1}	Error 1	8-bits hexadecimal coded ASCII	^{*2}
	
	Error 32 ^{*1}	8-bits hexadecimal coded ASCII	

^{*1} The maximum number of errors may differ depending upon the software version of SCU-750. It is recommended that an application is designed as variable-length data.

SCU-750 Control Unit for Turbomolecular Pump

² Value corresponding to the error message is transmitted (refer to Table 20 and Table 21). The most recent error has the largest parameter number. When the number of errors being detected is under the maximum number, the value of parameter that is larger than the number of errors being detected is set to 0.

Pump operation mode	Value
Levitation	1
No Levitation	2
Acceleration	3
Normal	4
Deceleration (Brake)	5
Autotest	6
Tuning	7
Tuning Complete	8
[System Reservation]	9, 10, 11

Table 22 - Pump operation mode

Example:

Pump operation mode : 01_{hex} = 1 = Levitation
 The number of error : 02_{hex} = 2 errors
 Error 1 : 0D^{hex} = 13 = Disturbance Xh
 Error 2 : 0F_{hex} = 15 = Disturbance Xb
 Error 3 to 32 : 00_{hex} = No error detected

Parameter	1		2		3		4		5		6		7		8		9		10		11	
ASCII	0	1	0	2	0	D	0	F	0	0	0	0	0	0	0	0	0	0	0	0	0	0
HEX	30	31	30	32	30	44	30	46	30	30	30	30	30	30	30	30	30	30	30	30	30	30

Parameter	12		13		[Omitted]	28		29		30		31		32		33		34	
ASCII	0	0	0	0		0	0	0	0	0	0	0	0	0	0	0	0	0	0
HEX	30	30	30	30		30	30	30	30	30	30	30	30	30	30	30	30	30	30

SCU-750 Control Unit for Turbomolecular Pump

5.4.6 ReadVersion

Function: Read the software version of the SCU-750.

Transmission frame:

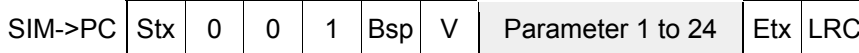
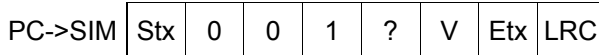

Parameter	Item	Data format	Remark
1 to 16	Control unit software version	8-bits hexadecimal coded ASCII	
17 to 20	Motor driver software version	4-bits ASCII character	Ver.1.2 = 0120
21 to 24	DSP software version (Digital control loop)	4-bits ASCII character	Ver.3.4 = 0340 * ¹
	(Analog control loop)	4-bits ASCII character	FFFF fixed * ¹

*¹ SCU-750 uses a digital control loop.

Example:

Control unit software version : 35365F4120312E3020202020202020_{hex} = 56_A 1.0

Motor driver software version : 0120_{hex} = 1.2

DSP software version : 0340_{hex} = 3.4

Parameter	1	2	3	4	5	6	7	8	9	10
	"5"	"6"	"_"	"A"	" "	"1"	."	"0"	" "	" "
ASCII	3 5	3 6	5 F	4 1	2 0	3 1	2 E	3 0	2 0	2 0
HEX	33 35	33 36	35 46	34 31	32 30	33 31	32 45	33 30	32 30	32 30

Parameter	11	12	13	14	15	16	17	18	19	20	21	22	23	24
	" "	" "	" "	" "	" "	" "	/	/	/	/	/	/	/	/
ASCII	2 0	2 0	2 0	2 0	2 0	2 0	0 1	2 0	0 3	4 0				
HEX	32 30	32 30	32 30	32 30	32 30	32 30	30 31	32 30	30 33	34 30				

SCU-750 Control Unit for Turbomolecular Pump

5.4.7 ReadCounters

Function: Reads serial number, hour counter and start counter.

Transmission frame:

PC->SIM Stx 0 0 1 ? c Etx LRC

SIM->PC Ack

PC->SIM Ack

SIM->PC Stx 0 0 1 Bsp c Parameter 1 to 23 Etx LRC

Parameter	Item	Data format	Remark
1 to 10	Control unit serial number	4-bits ASCII character	
11 to 20	Pump serial number	4-bits ASCII character	
21	Pump hour counter (Unit: minute)	32-bits hexadecimal coded ASCII	
22	Control unit hour counter (Unit: minute)	32-bits hexadecimal coded ASCII	
23	Start counter	32-bits hexadecimal coded ASCII	

Example:

Control unit serial number : 12345

Pump serial number : 6789A

Pump hour counter : 0000003C_{hex} = 60 minutes = 1 hour

Control unit hour counter : 0000028C_{hex} = 652 minutes = 10 hours and 52 minutes

Start counter : 00000064_{hex} = 100 times

Parameter	1	2	3	4	5	6	7	8	9	10	11	12	13	14	15	16	17	18	19	20
ASCII	1	2	3	4	5						6	7	8	9	A					
HEX	31	32	33	34	35	20	20	20	20	20	36	37	38	39	41	20	20	20	20	20

Parameter	21										22										23									
ASCII	0	0	0	0	0	0	0	3	C		0	0	0	0	0	2	8	C			0	0	0	0	0	0	0	6	4	
HEX	30	30	30	30	30	30	33	43			30	30	30	30	30	32	38	43			30	30	30	30	30	30	30	36	34	

SCU-750 Control Unit for Turbomolecular Pump

5.4.8 ReadSetPoint

Function: Reads the setting value of the "Speed Set Point" and TMS temperature. The "Speed Set Point" data is the same data as that of "ReadSpeedSetPoint".

Transmission frame:

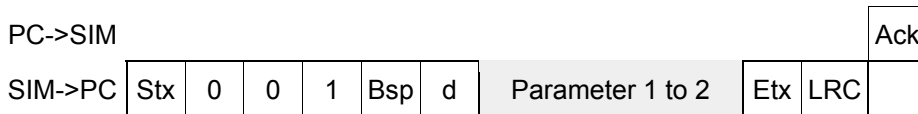
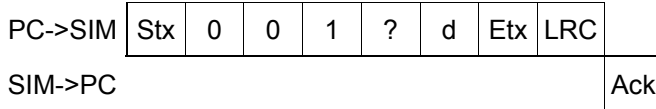

Parameter	Item	Data format	Remark
1	Speed Set Point (Unit: Hz)	16-bits hexadecimal coded ASCII	
2	TMS temperature setting (Unit: °C)	16-bits hexadecimal coded ASCII	

Example:

Speed Set Point : 01F4_{hex} = 500 Hz = 30,000 rpm
 TMS temperature setting : 003C_{hex} = 60 °C (140 °F)

Parameter	1				2			
ASCII	0	1	F	4	0	0	3	C
HEX	30	31	46	34	30	30	33	43

5.4.9 ReadMotorTemp

Function: Reads the measured motor temperature.

Transmission frame:

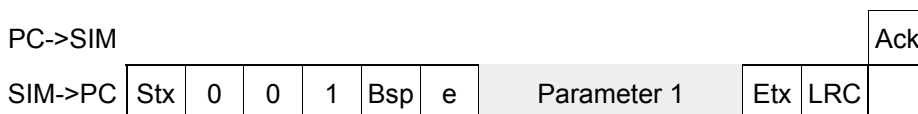
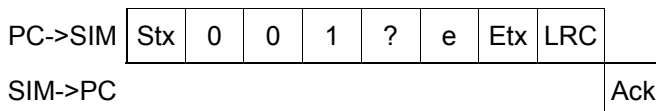

Parameter	Item	Data format	Remark
1	Motor temperature (Unit: °C)	16-bits hexadecimal coded ASCII	

Example:

Motor temperature : 0014_{hex} = 20 °C (68 °F)

Parameter	1			
ASCII	0	0	1	4
HEX	30	30	31	34

5.4.10 ReadStatus

Function: Reads various settings (Remote mode, TMS function, INHIBIT, Emergency vent valve).

Transmission frame:

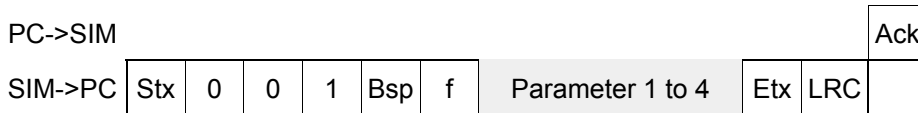
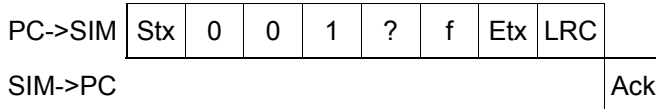

Parameter	Item	Data format	Remark
1	Remote mode setting	8-bits hexadecimal coded ASCII	Refer to Table 22
2	TMS function setting	8-bits hexadecimal coded ASCII	00 _{hex} : ENABLE Excluding 00 _{hex} : DISABLE
3	INHIBIT setting	8-bits hexadecimal coded ASCII	00 _{hex} : ENABLE Excluding 00 _{hex} : DISABLE
4	Emergency vent valve setting	8-bits hexadecimal coded ASCII	00 _{hex} : ENABLE Excluding 00 _{hex} : DISABLE

SCU-750 Control Unit for Turbomolecular Pump

Remote mode	Value
I/O Remote	1
RS232/485 Com	2
RS232/485 Modbus	3
LONWORKS	4
[System reservation]	5, 6, 7

Table 23 - Remote mode

Example:

- Remote mode setting : 01_{hex} = I/O Remote
- TMS function setting : 00_{hex} = ENABLE
- INHIBIT setting : FF_{hex} = DISABLE
- Emergency vent valve setting : FF_{hex} = DISABLE

Parameter	1		2		3		4	
ASCII	0	1	0	0	F	F	F	F
HEX	30	31	30	30	46	46	46	46

5.4.11 ReadEvents

Function: Reads the "Error Record". It has the most recent 10 errors that have been detected.

Transmission frame:

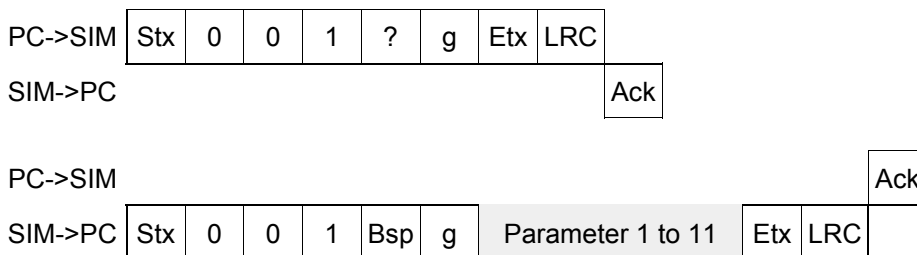

Parameter	Item	Data format	Remark
1	The number of "Error Record"	8-bits hexadecimal coded ASCII	Up to 10 errors
2 to 11	Error Record 1 to Error Record 10	8-bits hexadecimal coded ASCII	*1

*1 Value corresponding to the error message is transmitted (refer to Table 20). The most recent error has the smallest parameter number. When the number of errors being detected is under the maximum number, the value of parameter that is larger than the number of errors has been detected is set to 0.

Example:

When 3 errors have been detected in the past;

- The number of "Error Record" : 03_{hex} = 3 errors
- Error Record 1 : 0F_{hex} = 15 = Disturbance Xb
- Error Record 2 : 0D_{hex} = 13 = Disturbance Xh
- Error Record 3 : 15_{hex} = 21 = T.Cable Disconnected
- Error Record 4 to 10 : 00_{hex} = No error recorded

Parameter	1	2	3	4	5	6	7	8	9	10	11
ASCII	0 3	0 F 0 D	1 5	0 0	0 0	0 0	0 0	0 0	0 0	0 0	0 0
HEX	30 33	30 46 30 44	31 35	30 30	30 30	30 30	30 30	30 30	30 30	30 30	30 30

5.4.12 SetSpeedSetPoint

Function: Changes the "Speed Set Point" value. This value can be changed in the range from half of the rated rotational speed to the rated rotational speed.

Transmission frame:

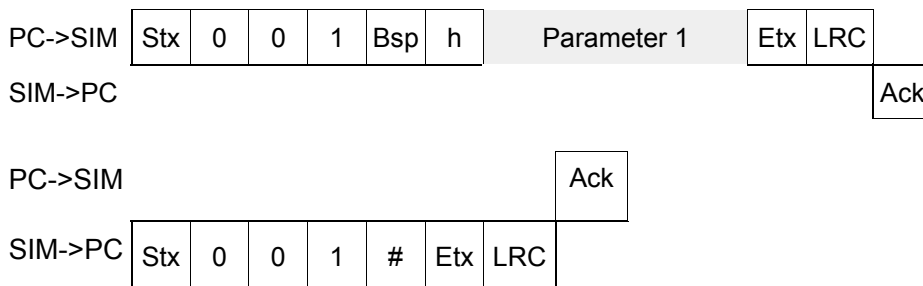

Parameter	Item	Data format	Remark
1	Speed Set Point (Unit: Hz)	16-bits hexadecimal coded ASCII	*1

*1 When the parameter value is larger than the rated rotational speed, it is automatically set to the rated rotational speed. When the parameter value is smaller than half of rated rotational speed, it is automatically set to half of rated rotational speed. The value of "Speed Set Point" displayed in LCD of SCU-750 is in increments of 500 rpm.

Example:

Speed Set Point : 01F4_{hex} = 500 Hz = 30,000 rpm

Parameter	1			
ASCII	0	1	F	4
HEX	30	31	46	34

5.4.13 ReadSpeedSetPoint

Function: Reads the "Speed Set Point" value. This value is the same as "ReadSetPoint" parameter 1 (Speed Set Point).

Transmission frame:

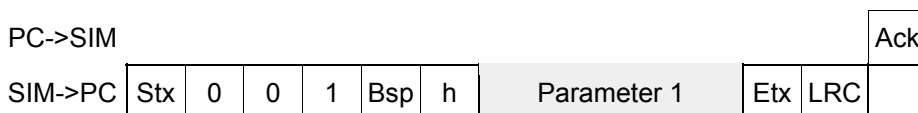
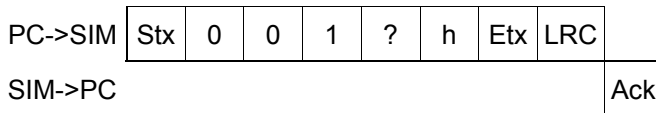

Parameter	Item	Data format	Remark
1	Speed Set Point (Unit: Hz)	16-bits hexadecimal coded ASCII	

Example:

Speed Set Point : 0320_{hex} = 800 Hz = 48,000 rpm

Parameter	1			
ASCII	0	3	2	0
HEX	30	33	32	30



SCU-750 Control Unit for Turbomolecular Pump

Example:

TMS temperature: $3C_{hex} = 60\text{ °C} (140\text{°F})$
 Motor temperature: $14C_{hex} = 20\text{ °C} (68\text{°F})$
 Measured rotational speed: $02DC_{hex} = 732\text{ Hz} = 43,920\text{ rpm}$

Parameter	1																
ASCII	*1	*1	*1	*1	*1	*1	*1	*1	*1	*1	*1	*1	*1	*1	*1	*1	*1
HEX																	

Parameter	1												2			
ASCII	*1	*1	*1	*1	*1	*1	*1	*1	*1	*1	*1	*1	0	0	3	C
HEX													30	30	33	43

Parameter	3				4										5					
ASCII	0	0	1	4	*1	*1	*1	*1	*1	*1	*1	*1	*1	*1	*1	*1	0	2	D	C
HEX	30	30	31	34													30	32	44	43

Parameter	6															
ASCII	*1	*1	*1	*1	*1	*1	*1	*1	*1	*1	*1	*1	*1	*1	*1	*1
HEX																

*1 System reservation



SCU-750 Control Unit for Turbomolecular Pump

This page intentionally blank.

6 MAINTENANCE

The SCU-750 is provided with safety functions for various abnormalities/errors. If an abnormality/error is found when using the STP pump, check it and take measures in accordance with the following procedures. If you cannot trace it or if the STP pump does not function normally after the troubleshooting, fill in the necessary information in the "Return Declaration" and fax it to Service office.

6.1 Safety functions

6.1.1 Power failure

When the power voltage drops below 80 V due to a power failure or another fault, the normal operation of the magnetic bearing is maintained at the high rotational speed using the regenerative energy of the rotating rotor (backup operation during a power failure).

The lowest rotational speed to which the magnetic bearing can operate at a power failure is called a backup rotational speed. The lowest backup rotational speeds vary according to the model of STP pump used, refer to Table 24.

1. When the rotational speed is at backup rotational speed or more at a power failure:
 The SCU-750 detects any power failure of 2 seconds or more and the STP pump decelerates. At this time, the "POWER" LED extinguishes and the "FAILURE" LED illuminates. The LCD displays "Mains Failure". An alarm signal is output from REMOTE X7 pins (14)-(33) and (15)-(33). When the rotational speed reaches the backup rotational speed, the rotor lands on the touch down bearing and stops. The "FAILURE" LED extinguishes and the LCD is turned off. The alarm signal output is reset.
 The SCU-750 does not detect a power failure of less than 2 seconds and the STP pump will continue to rotate.

2. When the rotational speed is less than backup rotational speed at a power failure:
 The SCU-750 does not detect the power failure. The rotor lands on the touch down bearing and stops.

Connected pump	Backup rotational speed
STP-603/1003 series	Approximately 8,000 rpm
STP-H301/H451 series	Approximately 15,000 rpm
STP-H803/H1303 series	Approximately 8,000 rpm
STP-A803/A1303 series	Approximately 8,000 rpm
STP-A1603 series	Approximately 8,500 rpm

Table 24 - Backup rotational speed

SCU-750 Control Unit for Turbomolecular Pump

Table 25 shows the status of LCD, LEDs, and REMOTE output signals at a power failure.

Rotational speed	Duration of power failure	LCD	LEDs		REMOTE output signal (REMOTE X7)		
		Error messages	POWER LED	FAILURE LED	POWER N.O.	ALARM	
						N.O.	N.C.
Backup rotational speed or more	Approx. 2 sec. or more	Mains Failure	Extinguish	Illuminate	Open	Close	Open
	Less than approx. 2 sec.	Continues as before					
Less than Backup rotational speed		OFF	Extinguish	Extinguish	Open	Open	Close

Table 25 - States of LCD, LEDs and REMOTE output signals at a power failure

6.1.2 Operation after a power recovery

1. The STP pump continues decelerating, and power failure detection is reset automatically.

At this time, the "POWER" LED illuminates and the "FAILURE" LED extinguishes. Also, POWER OUT pins (4)–(16) is closed, and a failure signal is reset between FAILURE OUT pins (8)–(21) and (9)–(21) of the "X2 REMOTE" connector.

2. When the START operation is performed after a power recovery, the STP pump reaccelerates even while it is in BRAKE state.

However, the SCU-750 may detect excessive vibration when power is recovered after the rotor lands on the touch down bearing (see Section 6.1.4). In this case, the STP pump once stops and cannot reaccelerate until the RESET operation completed (see Section 4.5.7).

Note: It is recommended to establish a procedure so that the power can be supplied to the SCU-750 immediately after a power recovery.

6.1.3 Abnormal state of magnetic bearing

CAUTION

When an abnormality/error occurs in the magnetic bearing, check the STP pump as well as the SCU-750.
If "FAILURE" cannot be released after reset operation, contact Service office.

When the magnetic bearing does not function normally due to a breakage of the STP connection cable, disconnection of connectors or any abnormality/error of the STP control circuit, the rotor lands on the touch down bearing and stops. The "FAILURE" LED illuminates and the LCD displays error message "Disturbance **".

6.1.4 Excessive vibration

When serious vibration or mechanical shock causes the rotor to come in contact with the touch down bearing (due to external vibration/impact, intrusion of atmosphere or foreign matter into the STP pump or rotor imbalance), the STP pump decelerates and stops.

The "FAILURE" LED illuminates and the LCD displays error message "Disturbance **".

6.1.5 Motor driver overload

When the STP pump does not attain the rated speed within approximately 30 minutes after starting or when the ACCELERATION state remains unchanged during operation for approximately 30 minutes, the STP pump decelerates and stops.

The "FAILURE" LED illuminates and the LCD displays error message "Driver Overload".

6.1.6 Overheating inside the STP pump

When the motor inside the STP pump overheats due to an abnormal high temperature or overload operation, the STP pump decelerates and stops.

The "FAILURE" LED illuminates and the LCD displays error message "Motor Overheat".

6.1.7 Overheating inside the SCU-750

The temperature in the SCU-750 increases when the ventilating duct is blocked or the ambient temperature is high. The LCD displays error message "CAUTION : CNT heat **" when the inside of the SCU-750 overheats. In this case, the pump does not stop.

When the SCU-750 overheats continuously, the STP pump decelerates and stops.

The "FAILURE" LED illuminates and the LCD displays error message "CNT Overheat **".

6.1.8 Overspeed

When the rotational speed of the STP pump exceeds the specified rotational value due to a failure in the motor driver, the MAIN POWER on the SCU-750 switches "OFF". The STP pump has no power supplied, decelerates and stops.

The "FAILURE" LED illuminates and the LCD displays error message "Overspeed *".

6.1.9 Abnormality/Error in the TMS unit (for use with the TMS unit)

If the temperature of the STP pump base unit is higher than the setting value by 10 °C (18 °F) or more due to the occurrence of an abnormality/error in the TMS heater or other fault, the "FAILURE" LED illuminates and the LCD displays error message "TMS Higher Temp". The heater is switched OFF and the cooling water unit is operated. The STP pump decelerates and stops. Continue to operate the cooling water unit while "TMS Higher Temp" is displayed after the pump stops.

If the temperature of the STP pump base unit is lower than the setting value by 10 °C (18 °F) or more due to the occurrence of an abnormality/error in the TMS heater or other fault, the "FAILURE" LED illuminates and the LCD displays the error message "TMS Lower Temp". The heater and the cooling water unit are switched OFF and the STP pump decelerates and stops.

Note: "TMS Lower Temp" is not detected for a certain time when the STP pump starts.

When an abnormality/error occurs in the TMS connection cable, the STP pump decelerates and stops. The heater and the cooling water unit are switched OFF.

The "FAILURE" LED illuminates and the LCD displays the error message "T.Cable Disconnect".

6.2 "WARNING" message function

6.2.1 "WARNING" message display function

The SCU-750 is provided with a "WARNING" message to display when an overhaul is needed following a self test. When a "w" appears in the upper left hand corner of the LCD, press the "ENTER" switch to display the warning message for a few seconds (The "ENTER" switch can also be used in REMOTE mode). The warning message indicates that an overhaul is necessary. Please contact Service office for an overhaul.

Example:

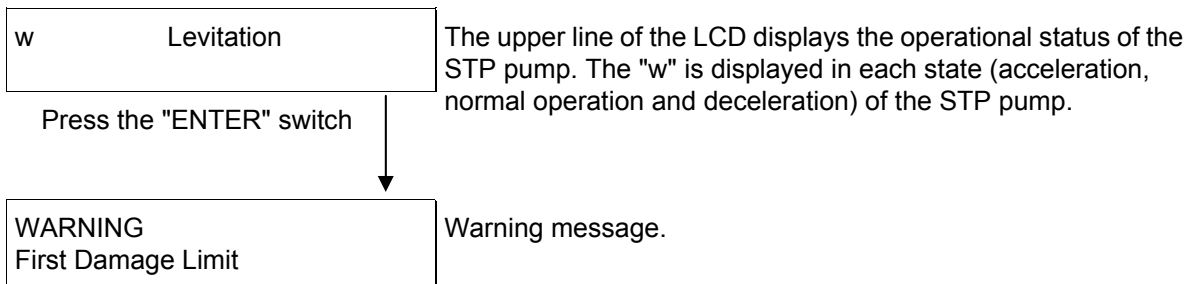

*Note: The "WARNING" message cannot be reset by the "RESET" switch.
The "WARNING" message should be reset by Service office.
The STP pump can operate even when the "WARNING" message is displayed except when the "Second Damage Limit" is displayed.*

6.3 "WARNING" message description

6.3.1 Damage point function

Impact of the STP pump rotor onto the touch-down bearing, such as by an unexpected in-rush of air from outside or in the event of power failure, can damage the touch-down bearings. The SCU-750 monitors these impacts and assigns damage points to the event of "Disturbance" or "Mains Failure". The damage point increases with the rotational speed up to 15 point for each "Disturbance", and 1 point for each touch-down at "Mains Failure".

Refer to Section 3.10, "Confirmation Mode" about confirmation method of damage point.

STP pump	Warning message	
	First Damage Limit	Second Damage Limit
STP-603/1003 series STP-H301/H451 series STP-H803/H1303 series STP-A803/A1303 series STP-A1603 series	120 or more	150 or more

Table 26 - Accumulated damage point and warning message

6.3.2 First damage limit

"First Damage Limit" is displayed when the accumulation point attains the setting value shown in Table 26. The rotating operation can be performed though "WARNING" message is displayed. It is recommended to have the STP pump overhauled as soon as possible.

6.3.3 Second damage limit

"Second Damage Limit" is displayed when continuing to operate the STP pump after "First Damage Limit" is displayed and the accumulation of the damage point attains the setting value by further "Disturbance" and "Mains Failure".

Overhaul the STP pump because the STP pump cannot perform the rotational operation when "Second Damage Limit" is displayed.

When operating the STP pump is needed after "Second Damage Limit" is displayed, disable the "Second Damage Limit". The rotating operation can be performed even though the "WARNING" message is displayed. Refer to Section 3.11 for the setting method.

6.3.4 CAUTION X_H, X_B, Z

Imbalance in the STP pump rotor is always monitored. Either "CAUTION X_H", "CAUTION X_B" or "CAUTION Z" is displayed when imbalance of the synchronized rotor with the rotational speed exceeds the setting value.

When deposited matter accumulates in the STP pump, with the increase of the STP pump operation hours, the rotor balance is lost and the imbalance increases gradually. An increase in the amount of deposited matter may lead to a malfunction of the STP pump by detecting the "Disturbance" error.

The rotating operation can be performed even though the "WARNING" message is displayed. However, it is recommended to have the STP pump overhauled as soon as possible.

SCU-750 Control Unit for Turbomolecular Pump

6.4 Error at self test state

When an abnormality/error occurs during the self test while operating the ON switch, the safety function operates, the "FAILURE" LED illuminates and an alarm signal is output from the REMOTE X7 connector (see Table 9). An error message showing "CAUTION" on the upper line and the contents of the error are displayed on the lower line of the LCD. If an abnormality/error is found, take measures in accordance with Table 27.

LCD messages	Probable causes	Countermeasures	Referred section
CAUTION New Serial Number	The different STP pump is used after the tuning is performed.	Perform tuning.	Section 4.2.2 Section 3.9.1
CAUTION New Pump Model	The STP pump of a different model is used after the tuning is performed.	Perform tuning.	Section 4.2.2 Section 3.9.1
CAUTION Incorrect Ctrl Data	Turning on the power after "Tuning Error" is detected.	Perform tuning.	Section 3.9.1
	Abnormal data in SCU-750.	Perform tuning.	Section 3.9.1
	Failure of the SCU-750.	Contact Service office.	
CAUTION Incorrect Pump Data	Abnormal data in STP pump.	Perform tuning.	Section 3.9.1
	Failure of the SCU-750 or STP pump.	Contact Service office.	
CAUTION Incorrect Pump & Ctrl Data	Abnormal data in STP pump and the SCU-750.	Perform tuning. Reconfigure the initialized setting.	Section 3.9.1
	Failure of the SCU-750 or STP pump.	Contact Service office.	
CAUTION Different Pump ID	Failure of the SCU-750 or STP pump.	Contact Service office.	
CAUTION Unavailable Pump	The inappropriate STP pump is used.	Confirm if the appropriate STP pump is connected.	Section 2.1
CAUTION Ctrl Record Failure	Update failure of the SCU-750 data.	Contact Service office.	
CAUTION Pump Record Failure	Update failure of the STP pump data	Contact Service office.	

Table 27 - Error messages at self test state

6.4.1 Error after self test

If an abnormality/error occurs after the self test, the safety function operates, the "FAILURE" LED and an alarm signal is output from the REMOTE X7 connector (see Table 9). An error message showing the number of the error in the form "Error n° **/**" and the contents of the error are displayed alternately on the lower line of the LCD.

6.4.2 Error messages

The first number of "***/**" is the order of detected errors (the earliest error is number 1) and the second number shows the number of errors that have occurred. Thus, a "1/3" would denote the earliest error of 3 errors. Press the "UP" or "DOWN" switch to scroll through the LCD display menu to view the contents of the next or previous error message. (The "UP" or "DOWN" switch can also be used in REMOTE mode)

Example:

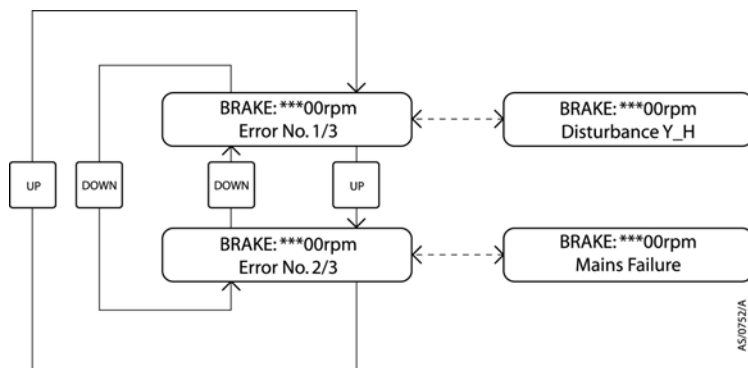

Note: The upper message on the LCD shows the current STP pump operation state. The lower message on the LCD is alternately displayed.

6.4.3 Troubleshooting immediately after power failure occurs

It is recommended to establish a procedure so that the power can be supplied to the SCU-750 immediately after a power recovery.

6.4.4 Troubleshooting immediately after other abnormality/errors occur

CAUTION

When disconnecting cables from the STP pump and/or the SCU-750 to perform troubleshooting and take the necessary action, confirm that the STP pump has stopped, turn OFF the primary power (turn the MAIN POWER "OFF") and isolate the electrical energy source (Lockout/Tagout) on the vacuum equipment, then disconnect the cables.

If the RESET operation does not extinguish the "FAILURE" LED, confirm that the STP pump has stopped, turn OFF the primary power (switch the MAIN POWER "OFF"), then turn ON the primary power again (turn the MAIN POWER "ON").

Refer to Section 4.4.4.

- After confirming the "BRAKE" LED has extinguished and the STP pump stops, remove the probable cause of the abnormality. When the LCD displays an error message, take the necessary action according to Table 28 to Table 33.
- Perform the RESET operation, to turn off the "FAILURE" LED.
- Perform the START operation. Check if the STP pump operates correctly.

SCU-750 Control Unit for Turbomolecular Pump

LCD Messages	Occurrence condition	Pump operation	Probable causes	Countermeasures	Referred section
CAUTION: CNT heat1	Overheat inside the SCU-750.	Continuance of rotation.	<ol style="list-style-type: none"> 1. High ambient temperature. 2. Insufficient cooling of the SCU-750. 3. Failure of the air-cooling fan in the SCU-750. 	<ol style="list-style-type: none"> 1. Set the ambient temperature to 40 °C (104 °F) or less. 2. Remove obstacle from the ventilation port. 3. Contact Service office. 	<p>Section 3.4.1</p> <p>Section 3.4.3</p>
CAUTION X_H, CAUTION X_B, CAUTION Z	Excessive displacement of the rotor during normal operation.	Continuance of rotation. "w" is displayed.	<ol style="list-style-type: none"> 1. Any deposit adhered to the rotor. 2. Excessive disturbance. 	<ol style="list-style-type: none"> 1. Overhaul is needed. Contact Service office. 2. Contact Service office. 	Section 6.3.3
CNT Overheat 1	Overheat inside the SCU-750.	Decelerate and stop.	<ol style="list-style-type: none"> 1. High ambient temperature. 2. Insufficient cooling of the SCU-750. 3. Failure of the air-cooling fan in the SCU-750. 	<ol style="list-style-type: none"> 1. Set the ambient temperature to 40 °C (104 °F) or less. 2. Remove obstacle from the ventilation port. 3. Contact Service office. 	<p>Section 3.4.1</p> <p>Section 3.4.3</p>
Disturbance X_B Disturbance X_H Disturbance Y_B Disturbance Y_H Disturbance Z	Excessive imbalance.	Contact noise and vibration of the rotor are generated from the STP pump. Decelerate and stop.	<p>Abnormal magnetic bearing:</p> <ol style="list-style-type: none"> 1. Change of the cable length. 2. Disconnection of the STP connection cable or control circuit error. <p>Excessive vibration applied externally to the STP pump:</p> <ol style="list-style-type: none"> 1. External vibration/impact. 2. Atmospheric air flows into the STP pump. 3. Foreign matter falls into the STP pump. 	<ol style="list-style-type: none"> 1. When changing the cable length, perform tuning. 2. Contact Service office. 	Section 3.9
				<ol style="list-style-type: none"> 1. Remove external vibration so as not to transmit it to the STP pump. 2. Check the vacuum piping. 3. Install the STP pump in a way that no foreign matter falls into the STP pump. 	Instruction Manual (B)

Table 28 - Error messages after self test

SCU-750 Control Unit for Turbomolecular Pump

LCD Messages	Occurrence condition	Pump operation	Probable causes	Countermeasures	Referred section
Driver Com Failure	Failure of serial communication.	Decelerate and stop.	Failure of the SCU-750.	Contact Service office.	
Driver Overcurrent	Driver overcurrent.	Free run. ^{*1}	1. Short of the STP connection cable. 2. STP pump failure.	1. Contact Service office. 2. Contact Service office.	
Driver Overload	ACCELERATION state continues for approximately 30 minutes.	Decelerate and stop.	1. High pressure at the inlet port. 2. High pressure at the outlet port. 3. Leakage of the piping system. 4. Failure of the backing-pump.	1. Use the maximum working pressure or less. 2. Use the allowable backing pressure or less. 3. Check the vacuum piping system for leakage. 4. Check the backing-pump for its capacity and START state. (use a backing-pump with the recommended capacity or more)	Instruction Manual (B)
Driver Overvoltage	Driver overvoltage.	Free run. ^{*1}	Failure of the SCU-750.	Contact Service office.	
DSP Initialize Fail	Abnormal CPU operation.	Touch down. The magnetic bearing output stops and the rotor is descended on the touch down bearing.	Failure of the SCU-750.	Contact Service office.	
DSP->PCB Com Fail	Serial communication failure.	Decelerate and stop.	Failure of the SCU-750.	Contact Service office.	

^{*1} The driver output stops and the rotor continues rotating by inertia. It may take several hours to stop. To stop the STP pump quickly, close the vacuum valve at the outlet port flange and introduce gas from the purge port into the STP pump.

Table 29 - Error messages after self test (continued)

LCD Messages	Occurrence condition	Pump operation	Probable causes	Countermeasures	Referred section
E_valve disconnect	Disconnection of the emergency vent valve cable.	Decelerate and stop.	<ol style="list-style-type: none"> 1. Disconnection of the emergency vent valve cable. 2. Incorrect setting of the emergency vent valve. 3. Failure of the emergency vent valve cable. 	<ol style="list-style-type: none"> 1. Connect the cable correctly. If the cable is not locked, lock it securely. 2. Set "LEAK Valve Option" to "DISABLE". 3. Contact Service office. 	Section 3.1.1
First Damage Limit	First damage phenomenon appeared on the touch down bearing.	Continuance of rotation. "w" is displayed.	Frequency of "Disturbance" or "Mains Failure" error.	Overhaul is needed. Contact Service office.	Section 6.3.1
Inordinate Current	Excessive magnetic bearing electric current continues for 30 sec.	Touch down. The magnetic bearing output stops and the rotor is descended on the touch down bearing.	<ol style="list-style-type: none"> 1. Failure of the STP pump. 2. Failure of the SCU-750. 	<ol style="list-style-type: none"> 1. Contact Service office. 2. Contact Service office. 	
M_Temp Sensor Lost	Disconnection of the temperature sensor of the STP pump.	Decelerate and stop.	Failure of the STP pump.	Contact Service office.	
Mains Failure	Insufficient power supply.	Decelerate and stop.	<ol style="list-style-type: none"> 1. Power failure. 2. Incorrect connection of the power cable. 3. Failure of the power cable. 4. Insufficient power supply voltage. 	<ol style="list-style-type: none"> 1. Check whether or not a power failure has occurred. 2. Connect the power cable correctly. 3. Replace the power cable. 4. Set the voltage to the rated voltage $\pm 10\%$. 	Section 6.1.1 Section 3.6 Section 3.6.3 Section 2.1

Table 30 - Error messages after self test (continued)

SCU-750 Control Unit for Turbomolecular Pump

LCD Messages	Occurrence condition	Pump operation	Probable causes	Countermeasures	Referred section
Motor Overheat	Overheating inside the STP pump.	Decelerate and stop.	<ol style="list-style-type: none"> Overheating during baking. Insufficient cooling. Leakage of the vacuum piping system. Repetition start/stop operations. 	<ol style="list-style-type: none"> Set the temperature of the baking heater to 120 °C (248 °F) or less. At the time of baking or gas pumping, always cool the STP pump. Check the piping system for leakage. Repetition start/stop operations may cause the STP pump to overheat. 	<p>Instruction Manual (B)</p> <p>Instruction Manual (B)</p> <p>Section 4.1.1</p> <p>Section 4.1.2</p>
Overspeed 1 Overspeed 2 Overspeed 3	Rotational speed exceeds rated speed.	Breaker OFF. Decelerate and stop.	Failure of the SCU-750.	Contact Service office.	
P.Cable Disconnected	Disconnection of the STP connection cable.	Touch down. The magnetic bearing output stops and the rotor is descended on the touch down bearing.	<ol style="list-style-type: none"> Incorrect connection of the STP connection cable. Failure of the STP connection cable. 	<ol style="list-style-type: none"> Connect the cable correctly. If the cable is not locked, lock it securely. Contact Service office. 	Section 3.6.1
PCB->DSP Com Fail	Failure of serial communication.	Decelerate and stop.	Failure of the SCU-750.	Contact Service office.	
Power Supply Failure	Abnormal power circuit.	Decelerate and stop.	Failure of the SCU-750.	Contact Service office.	
Ram Error	Abnormal memory.	Decelerate and stop.	Failure of the SCU-750.	Contact Service office.	
Second Damage Limit	When the extent of the damage on the touch down bearing exceeds the second damage limit.	Decelerate and stop. "w" is displayed.	Frequency of "Disturbance" or "Mains Failure" error.	Overhaul is needed. Contact Service office.	

Table 31 - Error messages after self test (continued)

SCU-750 Control Unit for Turbomolecular Pump

LCD Messages	Occurrence condition	Pump operation	Probable causes	Countermeasures	Referred section
Speed Pulse Lost	Abnormal rotational speed detection.	Free run. ^{*1}	1. STP pump failure. 2. Failure of the SCU-750.	1. Contact Service office. 2. Contact Service office.	
START NOT ALLOWED	"Second Damage Limit" occurs.	Touch down. The magnetic bearing output stops and the rotor lands on the touch down bearing. Rotation is inoperative.	Frequency of "Disturbance" or "Mains Failure" error.	Overhaul is needed. Contact Service office. Set "Warning Damage Point" to "DISABLE" to release the error and continue operation temporarily.	Section 6.3.3 and 3.11.1
T. Cable Disconnect	TMS connection cable is not connected when the state "TMS Function" is set to "ENABLE".	Decelerate and stop.	1. Disconnection of the TMS connection cable. 2. Failure of the TMS connection cable. 3. Incorrect setting of the TMS function.	1. Connect the cable correctly. If the cable connector is not locked, lock it securely. 2. Contact Service office. 3. When the TMS function is not in use, set the TMS function to "DISABLE".	Section 3.6.2 Section 3.11
TMS Higher Temp	TMS temperature control error (when the TMS unit detection temperature becomes higher than the setting value by 10°C (+18°F) or more.	Decelerate and stop.	1. Cooling failure of TMS unit. 2. Failure of TMS unit.	1. Connect the electromagnetic cooling water valve correctly. Check the volume of water and water temperature. 2. Contact Service office.	Instruction Manual (B)

*1 The driver output stops and the rotor continues rotating by inertia. It may take several hours to stop. To stop the STP pump quickly, close the vacuum valve at the outlet port flange and introduce gas from the purge port into the STP pump.

Table 32 - Error messages after self test (continued)

SCU-750 Control Unit for Turbomolecular Pump

LCD Messages	Occurrence condition	Pump operation	Probable causes	Countermeasures	Referred section
TMS Lower Temp	TMS temperature control error (when the TMS unit detection temperature becomes lower than the setting value by 10 °C (-18 °F) or more. Error is not detected for a certain time after the STP pump starts.	Decelerate and stop.	1. Failure of the TMS heater. 2. Failure of the TMS unit.	1. Contact Service office. 2. Contact Service office.	Instruction Manual (B)
TMS Sensor Lost	TMS sensor is not connected when the state "TMS Function" is "ENABLE".	Decelerate and stop.	1. Disconnection of the TMS sensor. 2. Incorrect setting of the TMS function. 3. Disconnection of the TMS connection cable. 4. Failure of the TMS connection cable.	1. Contact Service office. 2. When the TMS function is not in use, set the TMS function to "DISABLE." 3. Connect the cable correctly. If the cable connector is not locked, lock it securely. 4. Contact Service office.	Section 3.11 Section 3.6.2
Tuning Error 1 Tuning Error 2 Tuning Error 3 Tuning Error 4 Tuning Error 5	Tuning failure.	Touch down. The magnetic bearing output stops and the rotor is descended on the touch down bearing.	1. Failure of the STP pump. 2. Failure of the SCU-750.	Perform tuning after power ON/OFF operation. When the error is displayed after tuning, contact Service office.	Section 3.9

Table 33 - Error messages after self test (continued)

SCU-750 Control Unit for Turbomolecular Pump

6.5 When error message is not displayed on LCD

When the "FAILURE" LED illuminates and the LCD displays an error message, refer to Table 27 to Table 33.

6.5.1 Abnormalities when powering ON

No.	Symptom	Probable cause	Countermeasures	Referred section
1	The "POWER" LED does not illuminate.	Incorrect connection of power cable.	Connect the power cable correctly.	Section 3.6.3
		Abnormal power voltage.	Set the voltage to rated voltage $\pm 10\%$.	Section 2.1 Section 3.6.3
		Power failure.	Check if a power failure has occurred.	Section 6.1.1

Table 34 - Troubleshooting when powering ON

6.5.2 Abnormalities when performing rotational operation

No.	Symptom	Probable causes	Countermeasures	Referred section
1	The "ACCEL." LED does not illuminate.	The "MANUAL/ REMOTE" changeover switch is not in the correct position.	Slide the "MANUAL/ REMOTE" changeover switch to the correct position.	Section 3.2 Section 4.4 Section 4.5
		Rotation INHIBIT signal input pins (REMOTE X7 (1)-(5)) are open.	When not using this function, short the circuit between (1)-(5), or set "Inhibit Command" to "DISABLE". If these pins are open, the STP pump will not rotate after performing the start operation.	Section 4.5.1 Section 3.11

Table 35 - Troubleshooting when performing the STP pump start operation

6.5.3 Other abnormalities

No.	Symptom	Probable causes	Countermeasures	Referred section
1	The STP pump stops.	Rotation INHIBIT signal input pins (REMOTE X7 (1)-(5)) are open.	When not using this function, short the circuit between (1)-(5), or set "Inhibit Command" to "DISABLE". If these pins are open, the STP pump will not rotate after performing the start operation.	Section 4.5.1 Section 3.11
2	The TMS unit does not function.	Incorrect settings of TMS function.	When using the TMS unit, set "TMS Function" to "ENABLE".	Section 3.11
3	Rotation INHIBIT signal does not function correctly.	Incorrect settings of inhibit function.	When using the rotation INHIBIT signal, set "Inhibit Command" to "ENABLE".	Section 3.11

Table 36 - Troubleshooting while the STP pump is rotating

6.6 "Error Record" message display function

The SCU-750 can display the contents of up to the last 10 errors on the LCD. However, when "*" is displayed at the head of the message, it is not an error detected by the SCU-750.

To view the error record, press the "SELECT" switch several times (refer to Section 3.10).

The error number of up to the last 10 errors is displayed on the upper line of the LCD in the form "Error Record n° */**", and the error message is displayed on the lower line.

The first number of "**/*" shows the order of detected errors (the most recent error is number 1) and the second number shows the number of errors that have occurred up to 10. Thus, a "1/3" would denote the most recent error out of 3. Press the "UP" or "DOWN" switch to scroll through the list and display the contents of the next or previous error message in the error record. (The "UP" or "DOWN" switch can also be used in Remote Mode, refer to Section 3.10.)

6.7 Maintenance and inspection

CAUTION

The following notes must be understood and complied with before carrying out any maintenance or inspections on the SCU-750 or STP pump.

Stop the STP pump and turn OFF the primary power (turn the MAIN POWER "OFF") and isolate the electrical energy source (Lockout/Tagout) on the vacuum equipment, then ensure the LED and LCD are extinguished before performing maintenance and inspections on the STP pump and SCU-750.

Failure to do so may result in the inadvertent rotation of the STP pump, which may result in an accident.

Moreover, DO NOT remove the connector while the pump is rotating. The voltage might be output to connector according to the rotational speed, and it causes the electric shock or the failure.

DO NOT touch any place other than those specified when performing maintenance or inspecting the pump and NEVER open any panel because it could cause shock, malfunction, or short circuit.

Power OFF the peripheral equipments such as a baking heater before performing maintenance and inspections.

Only Edwards will replace the maintenance parts and will execute repair and overhaul. Contact Service office.

6.7.1 Cleaning

The method of cleaning the SCU-750 is shown below.

- Clean the outside of the SCU-750 with a dry wipe as required.
- When dust has accumulated in the ventilation port, wipe off or vacuum it with the cleaner. In this case, dust must not enter in the SCU-750.
- Clean off with a pure gas when dust has accumulated in the connector.
- When the label of the SCU-750 has been damaged, contact Service office.

6.7.2 Overhaul

The air-cooling fan used in the SCU-750 will deteriorate after long-term use. It is recommended to overhaul the SCU-750 once every two or three years as a target. This overhaul includes inspection and cleaning. Overhaul costs will be at your own charge. The costs of parts that need to be replaced because of deterioration or abrasion will be at your own charge. When overhaul of the SCU-750 is needed, contact Service office.

7 STORAGE, TRANSPORTATION AND DISPOSAL

7.1 Storage of the SCU-750

When planning not to use the SCU-750 over a long period (more than a few months), follow the precautions below:

1. Store the SCU-750 in a horizontal position.
2. DO NOT store the SCU-750 in the following areas:
 - Areas of high humidity, (if it must be stored in a place of high humidity, insulate it from the outside and use a dehumidifying agent.)
 - Areas prone to temperature extremes. High temperatures of no more than + 55 °C (131 °F), and low temperatures of less than –25 °C (13 °F).
 - Areas which will be subjected to direct sunlight.
 - Areas where corrosive gases may exist.
 - Areas subjected to water/dampness.
 - Areas subjected to excessive dust.
 - Areas with insufficient ventilation.
 - Areas subjected to strong magnetic and electric fields or radiation.
 - Areas subjected to electric noise and vibration.

7.1.1 Transporting for repair or overhaul

	WARNING Ensure you follow the "Return Procedure" to prevent an accident during the transportation, repair or overhaul.
---	--

CAUTION Edwards will not be responsible for any damage or problems that may occur when returning the SCU-750.

Always contact Service office before returning the SCU-750 for repairs, overhaul or other purposes.

When returning the SCU-750 to Service office, use the original packing to prevent external damage. If you do not have the original packing, use similar or superior packaging material.

"Return Procedure" and the "Malfunction Information" are in the end of the Instruction Manual. When additional sheet is needed, contact Service office.

Note: When returning the SCU-750 to Service office, fill in the necessary items in the "Return Declaration" and fax it to Service office.



SCU-750 Control Unit for Turbomolecular Pump

7.2 Disposal

Dispose of the SCU-750 as industrial waste in accordance with all local and national safety and environmental standards.

Note: Edwards will not be responsible for problems during or after disposal.

8 SERVICE, SPARES, AND ACCESSORIES

8.1 Introduction

Edwards products, spares and accessories are available from Edwards companies and from a network of distributors, which are listed on the last page of this document. A majority of these centres employ Service Engineers who have undergone comprehensive Edwards training courses. Order spare parts and accessories from your nearest Edwards company or distributor. When you order, state for each part required:

- Model and Item number of your equipment
- Serial number (if any)
- Item number and description of part

8.2 Service

Edwards products are supported by a world-wide network of Edwards Service office. Each Service office offers a wide range of options including: equipment decontamination; service exchange; repair; rebuild and testing to factory specifications. Equipment, which has been serviced, repaired or rebuilt, is returned with a full warranty.

Your local Service office can also provide Edwards engineers to support on-site maintenance, service or repair of your equipment.

For more information about service options, contact your nearest Service office or Edwards.

8.3 Spares

Air cooling fan: When exchanging, contact Service Office. Air-cooling fan should be replaced in Service office.

The possession periods of maintenance parts is for at least 7 years after the products is discontinued.

Contact Service office, when replacement is required.

SCU-750 Control Unit for Turbomolecular Pump

8.4 Accessories

The following is a list of accessories that can be purchased by contacting Edwards.

Items	Application purpose	Remarks
Instruction Manual (A) ^{*1}	Generic Instruction Manual	Supplied with STP pump
Instruction Manual (B) ^{*1}	Pump Specific Information	Supplied with STP pump
Instruction Manual (C) ^{*1}	Control unit Instruction Manual applicable to your STP pump	This manual Supplied with STP control unit
STP pump	STP pump	Refer to the STP pump Instruction Manual (B) for the applicable STP control unit.
Power cable	Primary input power	Standard cable length is 5 m. 10 m and 20 m versions are available. Contact Edwards for further information.
STP connection cable	Connection cable between the STP pump and the STP control unit	Standard cable length is 5m. 10 m and 20 m versions are available. Contact Edwards for further information.
TMS unit ^{*2}	Control the STP pump temperature	Except STP-603/1003 series
Air-cooling unit ^{*2}	For cooling the STP pump	
Baking heater ^{*2}	For baking the STP pump	

^{*1} STP pump consists of the three-volumed Instruction Manuals.

^{*2} Optional accessory

For more information, contact the nearest Service Office.

Manufacturer:

Edwards Japan Limited

1078-1, Yoshihashi, Yachiyo-shi, Chiba 276-8523 JAPAN

Telephone: Domestic 047-458-8822

International +81-47-458-8822

Facsimile: Domestic 047-458-8833

International +81-47-458-8833

■国内サービス拠点・ Domestic Service Office

エドワーズ株式会社

八千代サービスセンター

〒276-8523 千葉県八千代市吉橋 1078-1

TEL: 047-458-8854 FAX: 047-458-8835

<http://www.edwardsvacuum.co.jp>

EDWARDS JAPAN LIMITED

Yachiyo Service Center

1078-1, Yoshihashi, Yachiyo-shi, Chiba, 276-8523,
Japan

TEL: +81-47-458-8854 FAX: +81-47-458-8835

<http://www.edwardsvacuum.co.jp>

株式会社 旭精機

テクノセンター

〒836-0835 福岡県大牟田市西宮浦町 132-23

TEL: 0944-51-4448 FAX: 0944-52-9027

<http://www.asahiseiki.co.jp>

Asahi Seiki Co., Ltd.

Techno Center

132-23, Nishinomiya-cho, Ohmuta-shi,
Fukuoka, 836-0835, Japan

TEL: +81-944-51-4448 FAX: +81-944-52-9027

<http://www.asahiseiki.co.jp>

南九州事業所

〒899-0201 鹿児島県出水市緑町 230-105

TEL: 0996-62-8911 FAX: 0996-62-8999

Southern Kyushu Department

230-105, Midorimachi, Izumi-shi, Kagoshima,
899-0201, Japan

TEL: +81-996-62-8911 FAX: +81-996-62-8999

広島サービスセンター

〒739-0602 広島県東広島市西条町大字郷曾字下
原 363-7

TEL: 0824-25-1888 FAX: 0824-25-4034

Hiroshima Service Center

363-17, Azashimohara, Ooazagouso, Saijou-cho,
Higashihiroshima-shi, Hiroshima, 739-0602, Japan

TEL: +81-824-25-1888 FAX: +81-824-25-4034

長崎サービスセンター

〒854-0065 長崎県諫早市津久葉町 6-64

TEL: 0957-25-4421 FAX: 0957-25-4422

Nagasaki Service Center

6-64, Tsukuba-cho, Isahaya-shi, Nagasaki,
854-0065, Japan

TEL: +81-957-25-4421 FAX: +81-957-25-4422

■ **Overseas Service Office**

United Kingdom

EDWARDS

World Headquarters
Manor Royal, Crawley, West Sussex, RH10 9LW,
United Kingdom
TEL: +44-1293-528844 FAX: +44-1293 533453
<http://www.edwardsvacuum.com>

France

EDWARDS

125 Avenue Louis Roche, 92238 Gennevilliers,
Cedex, Paris, France
TEL: +33-1-4798-2401 FAX: +33-1-4798-4454

Germany

EDWARDS

Ammerthalstrasse 36, 85551 Kirchheim, Munich,
Germany
TEL: +49-89-9919180 FAX: +49-89-99191840

Italy

EDWARDS

Via Carpaccio 35, 20090 Trezzano Sul Naviglio,
Milan, Italy
TEL: +39-02-48-4471 FAX: +39-02-48-401638

Wilmington/USA

EDWARDS

North American Headquarters
301 Ballardvale Street, Wilmington, MA 01887, USA
TEL: +1-978-658-5410 FAX: +1-978-658-7969

Santa Clara/USA

EDWARDS

3901 Burton Drive, Santa Clara, CA 95054, USA
TEL: +1-408-496-1177 FAX: +1-408-496-1188

Austin/USA

EDWARDS

8201 East Riverside Drive, Building 4, Suite 125,
Austin,
TX 78744, USA
TEL: +1-512-694-7259 FAX: +1-512-389-3378

Tempe/USA

EDWARDS

1810 West Drake, Suite 101, Tempe, AZ 85283,
USA
TEL: +1-602-777-7007 FAX: +1-602-777-2244

Israel

EDWARDS ISRAEL VACUUM LTD

5 Habarzel Blvd Gat 2000 Industrial Zone Qiryat Gat
82000, Israel
TEL: +972-7-6810633 FAX: +972-7-6810640

Korea

Edwards Korea Limited

Chunan A/S Center
625-7 Upsung-Dong, Cheonan City,
ChungchongNam-do, Korea, 330-290
TEL: +82-41-621-7070 FAX: +82-41-621-7700

Korea

Edwards Korea Limited

Headquarters
5F, Daewoo Eng. Building 9-3, Sunae-dong
Bundang-ku, Sunnam City, Gyeonggi-do, Korea
TEL: +82-31-716-7070 FAX: +82-31-738-1001

Singapore

Edwards Technologies Singapore Pte Limited

42 Loyang Drive, Loyang Industrial Estate,
Singapore 508962
TEL: +65-6546-8408 FAX: +65-6546-8407

China

**Edwards Technologies Trading (Shanghai)
Co.,Ltd**

23 Fu Te Road(N), Wai Gao Qiao Free Trade Zone,
Pudong, Shanghai, 200131, PRC. China
Tel: +86-21-5866-9618 FAX: +86-21-5866-9993

Taiwan

HIGHLIGHT TECH CORP.

Tainan Service Center/Headquarters
No. 106, Gung-Min South Road II An-Nan Area,
Tainan City, Taiwan 709
TEL: +886-6-2460296 FAX: +886-6-2471701
<http://www.high-light.com.tw>

Taiwan

HIGHLIGHT TECH CORP.

Hsinchu Service Center
No. 8, Guangfu S. Rd., Fenghuang Tsuen, Hukou
Shiang, Hsinchu, Taiwan 303
TEL: +886-3-5973325 FAX: +886-3-5973083

Return of Edwards Equipment - Procedure

INTRODUCTION

Before returning your equipment, you must warn Edwards if substances you used (and produced) in the equipment can be hazardous. This information is fundamental to the safety of our Service Centre employees and will determine the procedures employed to service your equipment.

Complete the Declaration (HS2) and send it to Edwards before you dispatch the equipment. It is important to note that this declaration is for Edwards internal use only, and has no relationship to local, national or international transportation safety or environmental requirements. As the person offering the equipment for shipment, it is your responsibility to ensure compliance with applicable laws.

GUIDELINES

- Equipment is '**uncontaminated**' if it has not been used, or if it has only been used with substances that are not hazardous. Your equipment is '**contaminated**' if it has been used with any substances classified as hazardous under EU Directive 67/548/EEC (as amended) or OSHA Occupational Safety (29 CFR 1910).
- If your equipment has been used with radioactive substances, biological or infectious agents, mercury, polychlorinated biphenyls (PCB's), dioxins or sodium azide, you must decontaminate it before you return it to Edwards. You must send independent proof of decontamination (for example a certificate of analysis) to Edwards with the Declaration (HS2). Phone Edwards for advice.
- If your equipment is contaminated, you must either:
 - Remove all traces of contamination (to the satisfaction of laws governing the transportation of dangerous/hazardous substances).
 - Or, properly classify the hazard, mark, manifest and ship the equipment in accordance with applicable laws governing the shipment of hazardous materials.

Note: Some contaminated equipment may not be suitable for airfreight.

PROCEDURE

1. Contact Edwards and obtain a Return Authorisation Number for your equipment.
2. Complete the Return of Edwards Equipment - Declaration (HS2).
3. If the equipment is contaminated, you must contact your transporter to ensure that you properly classify the hazard, mark, manifest and ship the equipment, in accordance with applicable laws governing the shipment of contaminated/hazardous materials. As the person offering the equipment for shipment, it is your responsibility to ensure compliance with applicable law. **Note: Equipment contaminated with some hazardous materials, such as semiconductor by-products, may not be suitable for airfreight - contact your transporter for advice.**
4. Remove all traces of hazardous gases: pass an inert gas through the equipment and any accessories that will be returned to Edwards. Where possible, drain all fluids and lubricants from the equipment and its accessories.
5. Seal up all of the equipment's inlets and outlets (including those where accessories were attached) with blanking flanges or, for uncontaminated product, with heavy gauge tape.
6. Seal equipment in a thick polythene/polyethylene bag or sheet.
7. If the equipment is large, strap the equipment and its accessories to a wooden pallet. If the equipment is too small to be strapped to a pallet, pack it in a suitable strong box.
8. E-mail via scan, fax or post a copy of the original with signature of the Declaration (HS2) to Edwards. The Declaration must arrive before the equipment.
9. Give a copy of the Declaration (HS2) to the transporter. You must tell your transporter if the equipment is contaminated.
10. Seal the original Declaration in a suitable envelope: attach the envelope securely to the outside of the equipment package, in a clear weatherproof bag.
WRITE YOUR RETURN AUTHORISATION NUMBER CLEARLY ON THE OUTSIDE OF THE ENVELOPE OR ON THE OUTSIDE OF THE EQUIPMENT PACKAGE.

Return of Edwards Equipment - Declaration

Return Authorisation Number: _____

You must:

- Know about all of the substances which have been used and produced in the equipment before you complete this Declaration
- Read the Return of Edwards Equipment - Procedure (HS1) before you complete this Declaration
- Contact Edwards to obtain a Return Authorisation Number and to obtain advice if you have any questions
- Send this form to Edwards before you return your equipment as per the procedure in HS1

SECTION 1: EQUIPMENT

Manufacturer's Product Name _____

Manufacturer's Part Number _____

Manufacturer's Serial Number _____

Has the equipment been used, tested or operated?

YES Go to Section 2 NO Go to Section 4

IF APPLICABLE:

Tool Reference Number _____

Process _____

Failure Date _____

Serial Number of Replacement Equipment _____

SECTION 2: SUBSTANCES IN CONTACT WITH THE EQUIPMENT

Are any substances used or produced in the equipment:

- Radioactive, biological or infectious agents, mercury, poly chlorinated biphenyls (PCBs), dioxins or sodium azide? (if YES, see Note 1) YES NO
- Hazardous to human health and safety? YES NO

Note 1: Edwards will not accept delivery of any equipment that is contaminated with radioactive substances, biological/infectious agents, mercury, PCB's, dioxins or sodium azide, unless you:

- Decontaminate the equipment
- Provide proof of decontamination

YOU MUST CONTACT EDWARDS FOR ADVICE BEFORE YOU RETURN SUCH EQUIPMENT

SECTION 3: LIST OF SUBSTANCES IN CONTACT WITH THE EQUIPMENT

Substance name	Chemical Symbol	Precautions required (for example, use protective gloves, etc.)	Action required after a spill, leak or exposure

SECTION 4: RETURN INFORMATION

Reason for return and symptoms of malfunction: _____

If you have a warranty claim: • who did you buy the equipment from? _____

• give the supplier's invoice number _____

SECTION 5: DECLARATION

Print your name: _____ Print your job title: _____

Print your organisation: _____

Print your address: _____

Telephone number: _____ Date of equipment delivery: _____

I have made reasonable enquiry and I have supplied accurate information in this Declaration. I have not withheld any information, and I have followed the Return of Edwards Equipment - Procedure (HS1).

Signed: _____ Date: _____

Note: Please print out this form, sign it and return the signed form as hard copy.