



# Leybold SV-16D, SV-25D

## Technical Specifications

SOGEVAC Rotary vane pump		SV 16 D		SV 25 D	
		50 Hz	60 Hz	50 Hz	60 Hz
Nominal pumping speed <sup>1)</sup>	m <sup>3</sup> · h <sup>-1</sup> (cfm)	16.0 (9.4)	18.7 (11)	25.0 (14.7)	29.0 (17)
Pumping speed <sup>1)</sup>	m <sup>3</sup> · h <sup>-1</sup> (cfm)	14.5 (8.5)	17.0 (10)	22.5 (13.3)	25.5 (15)
Ultimate partial pressure					
without gas ballast <sup>1)</sup>	mbar	≤ 0.5	≤ 0.5	≤ 0.5	≤ 0.5
	Torr	≤ 0.4	≤ 0.4	≤ 0.4	≤ 0.4
with gas ballast <sup>1)</sup>	mbar	≤ 1.5	≤ 1.5	≤ 1.5	≤ 1.5
	Torr	≤ 1.1	≤ 1.1	≤ 1.1	≤ 1.1
Water vapour tolerance <sup>1)</sup>	mbar	15		15	
	Torr	11.3		11.3	
Oil filling	l	2		2	
	qt	2.1		2.1	
Noise level	dB (A)	59		59	
Motor power (1~ + 3~), max.	kW	0.75	0.90	0.75	0.90
	hp	1.01	1.21	1.01	1.21
Nominal speed	rpm	1440	1750	1440	1750
Weight (with oil filling)	kg	25		25	
	lb	55.1		55.1	
Connections, intake and exhaust side		G 1/2"		G 1/2"	
Dimensions (W x H x D)	mm	268 x 247 x 440		268 x 247 x 440	
	in	10.5 x 9.72 x 17.3		10.5 x 9.72 x 17.3	

<sup>1)</sup> in acc. with DIN 28 400 et. seq.

<sup>2)</sup> 230 V ±10% only

\* Excerpt from our line of products. Details on other motor voltages/frequencies as well as accessories and maintenance materials are available upon request.



# PROVAC

## SALES

PHONE: 831-462-8900

FAX: 831-462-3536

WWW.PROVAC.COM

# Leybold SV-16D, SV-25D Pumping Curves

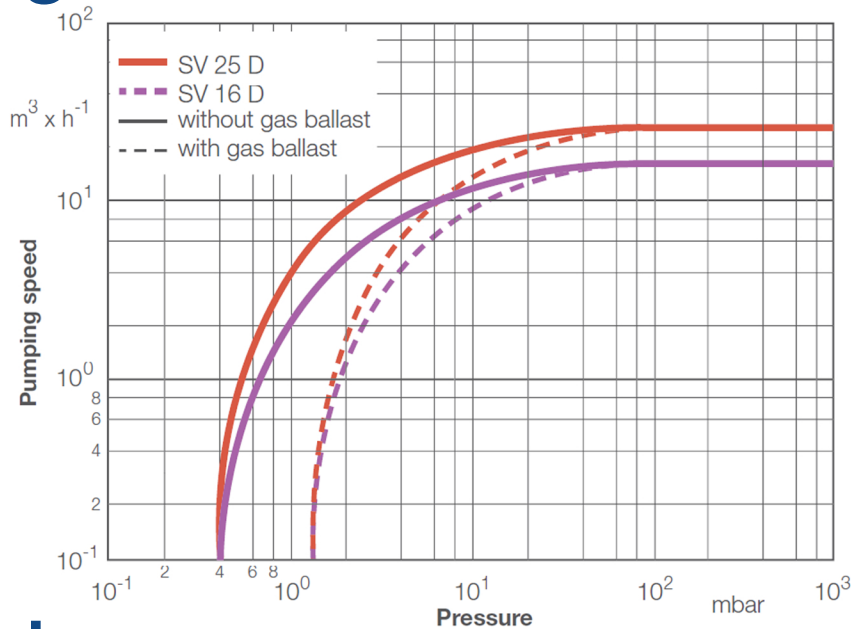

## Dimensions

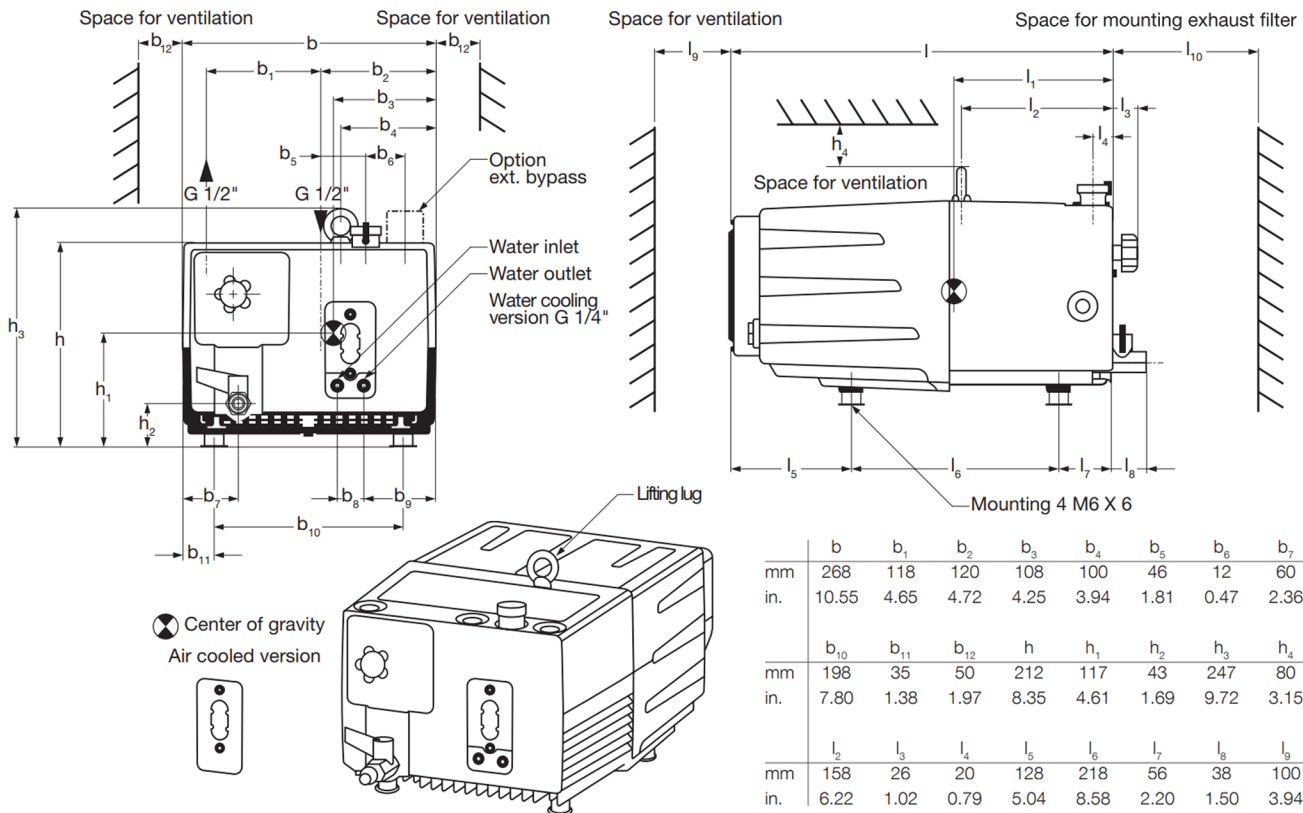



# PROVAC

## SALES

PHONE: 831-462-8900

FAX: 831-462-3536

WWW.PROVAC.COM

## Leybold SV-16D, SV-25D Features & Benefits

- compact & rugged design
- optimized pump temperature
- longer oil service life
- integrated lubrication with oil recovery system
- low noise level across entire operating pressure range
- integrated anti-suckback valve

## Applications

- oil processing • drying • degassing • rubber & plastic injection machines
- CO2 lasers • O2 applications • analytical instrumentation

