

Instruction Manual

STP Series Turbomolecular Pumps STP-iXA3306 Series



Read through the Safety Precautions and each section of this Manual carefully before using the STP pump.

Keep this Manual in a place where you can quickly access it at any time.





Declaration of Conformity

We,
Manufacture: Edwards Japan Limited
1078-1, Yoshihashi, Yachiyo-shi, Chiba, 276-8523, Japan
EU Representative: Edwards
Innovation Drive, Burgess Hill, West Sussex, RH15 9TW, UK

declare under our sole responsibility, as manufacturer and person within the EU authorised to assemble the technical file, that the product(s)

Product Name: Turbomolecular pump
Model Number: STP-iXA3306 series
Accessories Covered: Display Unit: iDT-001, TMS Unit,
Communication Interface (LonWorks, Profibus, Device Net, EtherCAT)

to which this declaration relates is in conformity with the following standard(s) or other normative document(s)

EN1012-2:1996, A1:2009 Compressors and Vacuum Pumps.
Safety Requirements. Vacuum Pumps
EN61010-1:2010 Safety Requirements for Electrical Equipment for Measurement,
Control and Laboratory Use. General Requirements
EN61326-1:2013 Electrical equipment for measurement, control and laboratory Use.
EMC requirements. General requirements
(Immunity: Industrial locations, Emission: Class A)
EN61000-6-2:2005 Electromagnetic compatibility (EMC). Generic standards.
Immunity for industrial environments
EN55011:2009, A1:2010 Industrial, scientific and medical equipment - Radio-frequency
disturbance characteristics (Group1, Class A)
EN50581:2012 Technical Documentation for the Assessment of Electrical and Electronic
Products with respect to the Restriction of Hazardous Substances

and fulfils all the relevant provisions of

2006/42/EC Machinery Directive
2014/35/EU Low Voltage Directive
2014/30/EU Electromagnetic Compatibility (EMC) Directive
2011/65/EU* Restriction of Certain Hazardous Substances (RoHS) Directive

* i.e. The product(s) contain less than - 0.1wt% for hexavalent chromium, lead, mercury, PBB and PBDE; 0.01wt% for cadmium - in homogeneous materials (subject to the exemptions allowed by the Directive). The RoHS Directive does not legally apply to industrial vacuum equipment until July 2019 (July 2017 for instruments).

Note: This declaration covers all product serial numbers from the date this Declaration was signed onwards.

Manufacture: 
Yuji Kato, TMP Technical Senior Manager, Edwards Japan Limited

5th June. 2016, Yachiyo
Date and Place

EU representative: 
Ian Stones, Vice President, Technology, Edwards

6th June. 2016, Burgess Hill
Date and Place

This product has been manufactured under a quality management system certified to ISO 9001:2008

CONTENTS

Section	Title	Page
1	INTRODUCTION	1
1.1	Scope and definitions	1
1.2	Applied standards	2
1.3	Limited warranty	2
1.3.1	Warranty period	2
1.3.2	Item warranted	3
1.3.3	Disclaimer	3
1.3.4	Spare parts	4
1.4	Precautions for safe operation of the STP pump	5
1.4.1	Usable gases	5
1.5	Maintenance and inspection precautions	6
1.6	Labels	6
1.7	Operation principle of the STP pump	8
1.8	STP pump specification	10
2	TECHNICAL DATA	13
2.1	STP pump specifications	13
2.2	Maximum gas flow-rate	14
2.2.1	STP-iXA3306C/CV	14
2.2.2	STP-iXA3306B/BV	15
2.3	Water cooling use condition	16
2.4	Control unit	17
2.5	External appearance of the STP pump	19
2.6	Label affixing positions	20
3	INSTALLATION OF THE STP PUMP	21
3.1	Precautions before installation	21
3.1.1	Operating environment	21
3.1.2	Installation area	23
3.1.3	Bench	24
3.1.4	Insulation test	24
3.2	Unpacking	25
3.2.1	Unpacking the STP pump	25
3.3	Name and function of each part	29
3.3.1	Name and function of the pump	29
3.3.2	Name and function of the control unit	30
3.4	How to install the STP pump	33
3.4.1	Cleaning the seal	34
3.4.2	STP pump installation positions	35
3.4.3	Secure the STP pump	36
3.4.4	Legs for securing the base	40
3.4.5	Power cable	41
3.4.6	How to connect the power cable	43
3.5	Precautions of vacuum piping	45
3.5.1	Vacuum piping method	45
3.6	Connecting the purge port	46

CONTENTS (CONTINUED)

Section	Title	Page
3.7	Connecting the water cooling pipe	47
3.8	Attaching a baking heater	48
3.9	Installation of the TMS unit	49
3.9.1	TMS unit specification	49
3.9.2	Configuration of the STP pump with the TMS	50
3.9.3	TMS heater	51
3.9.4	Connecting the TMS heater cable	51
3.9.5	TMS valve	51
3.9.6	Connecting the pump and TMS valve	52
3.10	Connecting to semiconductor equipment	53
3.10.1	Connecting to power	53
3.10.2	Emergency off circuit (EMO circuit)	53
4	OPERATION	55
4.1	Gas pumping, cooling and baking the STP pump	55
4.1.1	Gas pumping	55
4.1.2	How to introduce a purge gas	56
4.2	Cooling the STP pump	56
4.2.1	Water-cooling method	56
4.3	Baking the STP pump	57
4.4	Before starting the STP pump	58
4.4.1	Confirmation before starting	58
4.4.2	Confirmation of vacuum system	58
4.5	Powering ON	59
4.6	Pump operation	59
4.6.1	Input operation port setting	59
4.6.2	Starting/stopping the STP pump	60
4.7	How to start/stop the STP pump	62
4.7.1	Starting the STP pump after stopping	62
4.7.2	Starting the STP pump after a safety function operates	62
4.7.3	Powering OFF	62
4.8	LED	63
4.9	Parallel port input/output signal	64
4.9.1	Input signal pins	64
4.9.2	Input operation port setting	71
4.9.3	Rotation INHIBIT signal	72
4.9.4	Second speed option	73
4.9.5	Output signal pins	74
4.10	Operating the TMS unit (for use with the TMS unit)	78
4.10.1	Before starting	78
4.10.2	Starting/Stopping	78
4.10.3	Setting the TMS unit function	78

CONTENTS (CONTINUED)

Section	Title	Page
5	SERIAL COMMUNICATION PROTOCOL	79
5.1	Introduction	79
5.2	Connection and setting up	80
5.2.1	Signal connection	80
5.2.2	Connecting the RS485	82
5.2.3	Communication parameter setting	83
5.2.4	Input operation port setting	84
5.2.5	Serial communication timeout setting	85
5.2.6	Recommended items about communication cable installation	86
5.3	Protocol specifications	89
5.3.1	General description	89
5.3.2	Standard transmission frame	90
5.3.3	Control command (in the RS232/RS485 single point connection)	91
5.3.4	Query command (in the RS232/RS485 single point connection)	92
5.3.5	Transmission data format	93
5.3.6	Frame control (checksum)	94
5.3.7	Error control	94
5.3.8	Transmission frame in the RS485 multi-point connection	94
5.3.9	Control command in the RS485 multi-point connection	96
5.3.10	Query command in the RS485 multi-point connection	97
5.3.11	Broadcasting command in the RS485 multi-point connection	98
5.3.12	Application note	99
5.4	Command specifications	103
5.4.1	Command list	103
5.4.2	ReadMeas	104
5.4.3	Command	104
5.4.4	ReadFailMess	105
5.4.5	ReadModFonct	109
5.4.6	ReadVersion	111
5.4.7	ReadCounters	112
5.4.8	ReadSetPoint	113
5.4.9	ReadMotorTemp	113
5.4.10	ReadStatus	114
5.4.11	ReadEvents	115
5.4.12	SetSpeedSetPoint	116
5.4.13	ReadSpeedSetPoint	117
5.4.14	ReadModFonctWithWarning	118
5.4.15	ReadMeasValue	121
5.4.16	ReadOptionFunc	123
5.4.17	SetOptionFunc	126
5.4.18	ReadCondition	128
5.4.19	ReadEventsWithTime	130
5.4.20	SetOptions	134
5.4.20.1	Second speed option setting	134
5.4.20.2	Second speed selection	135

CONTENTS (CONTINUED)

Section	Title	Page
5.4.21	ReadOptions	136
5.4.21.1	Second speed function setting	136
5.4.21.2	Second speed select	137
6	STP-LINK AND DISPLAY UNIT	139
6.1	STP-Link	139
6.2	Display unit	140
7	SAFETY FUNCTIONS	141
7.1	Safety functions	141
7.1.1	Power Failure	141
7.1.2	Operation after a power recovery	142
7.1.3	Abnormal state of magnetic bearing (Disturbance)	143
7.1.4	Excessive vibration (Disturbance)	143
7.1.5	Motor driver overload (DRV Overload)	143
7.1.6	Overheating inside the STP pump (MOTOR Overheat)	143
7.1.7	Overheating inside the control unit (CNT Overheat)	143
7.1.8	Overspeed	144
7.1.9	Abnormality/Error in the TMS unit (for use with the TMS unit)	144
7.2	"WARNING" function	145
7.2.1	"WARNING" function	145
7.3	Contents of WARNING function	147
7.3.1	First Damage limit	147
7.3.2	Second Damage Limit	147
7.3.3	Pump run time over	147
7.3.4	Pump Overload	148
7.3.5	Imbalance	148
7.4	WARNING function setting	149
7.5	Troubleshooting immediately after failure occurs	150
7.5.1	After power failure	150
7.5.2	After other abnormality/error	150
7.6	Troubleshooting	151
7.6.1	Indication of "FAILURE" LED (red)	151
7.6.2	Indication of "FAILURE" LED (green)	158
7.6.3	No Indication of the "FAILURE" LED	158
8	MAINTENANCE AND INSPECTION	159
8.1	Maintenance and inspection	159
8.2	Cleaning	160
8.3	Inspecting the deposit	160
8.4	Maintenance	161
8.4.1	Recommended overhaul intervals	161
8.4.2	Standard replacement parts	161
8.4.3	Recommended maintenance intervals for main parts	162
8.5	Transporting for repair or overhaul	163



STP-iXA3306 Series Turbomolecular Pump

CONTENTS (CONTINUED)

Section	Title	Page
9	STORAGE AND DISPOSAL	165
9.1	Storage of the STP pump	165
9.2	Disposal	166
10	SERVICE, SPARES AND ACCESSORIES	167
10.1	Introduction	167
10.2	Service	167
10.3	Spares	167
10.4	Accessories	168

ILLUSTRATIONS

Figure	Title	Page
1	STP pump installation warning label	6
2	Hot surface warning label	6
3	Heavy product caution label	7
4	High voltage device caution label	7
5	Rotation instruction label	7
6	Cross sectional view of the STP pump	8
7	External appearance of STP-iXA3306C(V)/iXA3306B(V)	19
8	Label affixing positions	20
9	Space around the STP pump	23
10	Example of lifting the STP pump	25
11	Example of lifting the STP pump (horizontal positioning)	26
12	Jack-up the STP pump	27
13	Control unit bottom face	27
14	Prohibited matter	28
15	STP pump with eyebolts	28
16	Configuration of the STP pump	29
17	Control unit (Front panel)	30
18	Installation of the STP pump to the vacuum equipment	33
19	STP pump installation positions	35
20	Positions of the outlet port on the horizontally or slanted installed STP pump	35
21	Shape of reduced diameter shank bolts	39
22	Methods of securing the STP pump	39
23	Screw holes for securing the base	40
24	Power cable	41
25	Connecting method of the power cable	42
26	Connecting the purge port	46
27	Positions of the cooling water port	47
28	Baking heater installation position	48
29	Configuration of the TMS	50
30	TMS valve connection	52
31	Pump operation method 1 (contact input)	60
32	Pump operation method 2 (contact input)	60
33	Pump operation method 1 (voltage input)	61
34	Pump operation method 2 (voltage input)	61
35	"ROTATION" LED Indication	63
36	X2 REMOTE connector	64
37	X2 REMOTE input signal pins (contact input)	67
38	X2 REMOTE input signal pins (voltage input)	70
39	X2 REMOTE output signal pins	76
40	Serial port	79
41	X3/X4 connector (D-Sub9)	81
42	RS485 connections	82
43	Grounding example (Both ends grounding)	86
44	Grounding example (single point grounding)	86
45	Example of ring ferrite core installation	87
46	Example of cable installation in metallic duct	87
47	Example of differential signal waveform	88
48	PC to SIM communication	89
49	Block diagram of communication process example	99

ILLUSTRATIONS (CONTINUED)

Figure	Title	Page
50	Example of answer resending process	100
51	Example of response when the command is sent continuously	100
52	Example of command sending during answer data reply	100
53	Example of communication cycle process	101
54	Example of command sending process	102
55	Example of answer receiving process	102
56	Display unit iDT-001	140
57	WARNING output	146
58	Failure output	151

TABLES

Table	Title	Page
1	Maximum gas flow-rate (STP-iXA3306C)	14
2	Maximum gas flow-rate (STP-iXA3306CV)	14
3	Maximum gas flow-rate (STP-iXA3306B)	15
4	Maximum gas flow-rate (STP-iXA3306BV)	15
5	Environmental requirements for installation	22
6	Eyebolt size	25
7	Pump functions	29
8	Control unit front panel functions	31
9	Control unit front panel functions (continued)	32
10	Tightening torque of bolt	36
11	Maximum torque predicted and recommended securing bolt for inlet port flange	37
12	Power cable	41
13	TMS unit specification	49
14	Starting/stopping the STP pump using contact input (X2 REMOTE)	60
15	Starting/stopping the STP pump using voltage input (X2 REMOTE) (voltage input)	61
16	Reset Operation (X2 REMOTE)	62
17	LED Indications for each state	63
18	X2 REMOTE input signal pins	65
19	X2 REMOTE input signal pins (continued)	66
20	X2 REMOTE input signal pins (voltage input)	68
21	X2 REMOTE input signal pins (voltage input) (continued)	69
22	Input operation port setting	71
23	Rotation INHIBIT signal input	72
24	Second speed function	73
25	X2 REMOTE output signal pins	75
26	X2 REMOTE output signal pins (continued)	76
27	Rated contacts for relays CR1 to CR8	77
28	X3/X4 pin position	80
29	Communication parameters	83
30	Input operation port	84
31	Serial communication time out setting	85
32	Transmission control characters	90
33	Pump operation commands	98
34	Command list	103
35	Pump operation commands	105
36	Error message values	107
37	Error message values (continued)	108
38	Pump operation mode	110
39	Remote mode	115
40	Warning value bit assign	119
41	Parameter setting value	124
42	Option function number and parameter list	134
43	Option function number and parameter list	136
44	Functions of STP-Link	139
45	States of LEDs and X2 REMOTE output signals at power failure	142
46	WARNING function	145



STP-iXA3306 Series Turbomolecular Pump

TABLES (CONTINUED)

Table	Title	Page
47	Default setting of WARNING function	149
48	Factory Setting and Variable Range	149
49	Priority of failure signal	151
50	Error List	152
51	Error List (continued)	153
52	Error List (continued)	154
53	Error List (continued)	155
54	Error List (continued)	156
55	Error List (continued)	157
56	Troubleshooting with no indication of the "FAILURE" LED	158



STP-iXA3306 Series Turbomolecular Pump

PAGE
X

This page intentionally blank

1 INTRODUCTION

1.1 Scope and definitions

This manual provides installation, operation and maintenance instructions for the Edwards Turbomolecular Pump (abbreviated to "STP pump" throughout this manual). You must use the STP pump as specified in this manual otherwise the protection provided by the equipment may be impaired.

Important safety information is highlighted as WARNING and CAUTION instructions; these instructions are mandatory. The use of WARNINGS and CAUTIONS is defined below:

	WARNING Warnings are given where failure to observe the instruction could result in serious injury or death to people.
---	--

CAUTION Cautions are given where failure to observe the instruction could result minor personal injury in damage to the equipment, associated equipment and/or process.	
---	--

Note: Items you must follow during operation and maintenance.

Throughout this manual, page, figure and table numbers are sequential.

The units used throughout this manual conform to the SI international system of units of measurement; US equivalent units of measurement are also given.

The following IEC warning labels/symbols appear on the STP-iXA3306 Series Turbomolecular Pump and the STP Pump Instruction Manual:



Warning - This symbol denotes general warning
Refer to accompanying documentation and instruction manual.



Warning - Hazardous Voltage
This symbol denotes the risk of electrical shock.



Warning - Heavy object
This symbol denotes the risk of low back pain and fall.



Warning - Hot surface
This symbol denotes the risk of burns.

STP-iXA3306 Series Turbomolecular Pump

Note: An alarm function is incorporated into this STP series. Alarm and cautionary messages are displayed on the LCD of the display unit iDT-001 (optional accessory). Note that the words "WARNING" and "CAUTION" displayed on the LCD indicate the need for overhaul of the pump or precautions during the operation. They do not have the same meaning as the much more serious symbols for "WARNING" and "CAUTION" used in the instruction manual.

1.2 Applied standards

The STP pump conforms to the following directives and standards:

1. Applied Directives

- EC Machinery Directive
- EC Electromagnetic Compatibility Directive
- EC Low Voltage Directive

2. Applied Standards

- EN1012-2
- EN61010-1
- EN61326-1 (class A)
- EN61000-6-2
- EN55011
- UL61010-1, 2nd Edition (Electrical Equipment for Measurement, Control, Laboratory Use)
- SEMI S2-0310

3. Electromagnetic compatibility

- This product is a class A product according to EN61326, and a group 1, class A product according to EN 55011.
This means that this product does not generate and/or use intentionally radio-frequency energy, in the form of electromagnetic radiation, inductive and/or capacitive coupling, for the treatment of material or inspection / analysis purpose and that it is suitable for use in all establishments other than domestic and those directly connected to a low voltage power supply network which supplies buildings used for domestic purposes.
- This product may have potential difficulties in ensuring electromagnetic compatibility in other than industrial environments, due to conducted as well as radiated disturbances.
- This product must not be used in residential areas because it may cause interference if used in residential areas.



STP-iXA3306 Series Turbomolecular Pump

1.3 Limited warranty

This WARRANTY applies to the customer to whom Edwards has delivered this product.

1.3.1 Warranty period

Edwards warrants this product against defects for a period of two (2) years from the date of delivery or during the period specified in the agreement made by and between the customer and Edwards.

1.3.2 Item warranted

1. This warranty applies only to the product delivered from Edwards to the customer.
2. If any defect is found during this period, Edwards will, at its option, repair or recondition the product free of charge. The costs for repair or replacement of the product after the warranty period has passed will be at your own charge.

1.3.3 Disclaimer

Edwards makes no warranty with respect to any damage occurred due to any of the following during the warranty period:

1. Handling, operation or maintenance other than that specified herein.
2. Failure to follow any of the warnings or cautions enumerated in this manual.
3. Installation, operation or maintenance using parts which are not specified by Edwards.
4. Maintenance personnel other than those authorized by Edwards or Service office have disassembled, reconditioned, or tampered the product.
5. Defect resulting from the not-specified use of the product.
6. When the product is used under special conditions without obtaining the written consent of Edwards (particular gases, strong magnetic field and the radiation are added to the product).
7. Defect resulting from deposit.
8. Water cooling system defect resulting from water quality used.
9. Defect resulting from the installation of the product (exclude the installation by authorized personnel).
10. Deterioration in the external because of use (discoloration, scratches and so forth).
11. Product damage occurred during transport or other factors not attributable to Edwards.
12. Product breakage or damage due to natural disasters, fire or other external factors.
13. Deterioration in the basic performance due to the use of the product beyond limits of the use.



STP-iXA3306 Series Turbomolecular Pump

14. Any direct, incidental or consequential damage resulting from the use of the product.
15. When continuously operated without overhaul after the WARNING indication on the "Failure" LED of the control unit or the LCD ("WARNING" message) of the display unit iDT-001.
16. Overhaul and replacement of maintenance parts.

1.3.4 Spare parts

- Touch down bearing.
- Air-cooling fan

Touch down bearing and air-cooling fan should be replaced at Edwards, contact Edwards.

1.4 Precautions for safe operation of the STP pump

1.4.1 Usable gases

1. Chlorine or fluorine system gases can be used in corrosion resistant pumps. When you use the following gases, contact Edwards.
 - Gases including alkaline metals except Li gas.
 - Gases including Ga, Hg, In, or Sn.
 - HBr gas.
2. Non-corrosion resistant pump cannot use the above gases including chlorine and fluorine system gases.

	<p>WARNING</p> <p>To prevent an accident, confirm the characteristics of gases to be used, referring to the Material Safety Data Sheet (MSDS) you obtain from the gas supplier, and, keep MSDS and a safety advice of gas supplier.</p>
--	--

	<p>WARNING</p> <p>Warn of the danger of the gas with the warning label when the use gas is hazardous chemical material.</p>
--	--

	<p>WARNING</p> <p>Secure safety by wearing personal protective equipment when using the gas which might influence damage health. In addition, take appropriate measure for depending upon the properties of the gas to be used.</p>
--	--

<p>CAUTION</p> <p>NEVER use any gas that is not specified as usable in this Manual. The use of such gas may corrode the STP pump and damage it.</p>	
--	--

<p>CAUTION</p> <p>Introduce a dry N₂ gas (purge gas) to protect the inside of the STP pump when using reactive or corrosive gas, gas including hydrogen. The use of these gases may result in product damage.</p>	
---	--

<p>CAUTION</p> <p>Cool the STP pump to prevent the STP pump from overheating when pumping gases.</p>	
---	--

1.5 Maintenance and inspection precautions

Perform any maintenance or inspection of the STP pump under the condition that no power is applied to the STP pump (refer to SEMI S2 Section 13.2 - type 1), following Section 8, "MAINTENANCE AND INSPECTION".

1.6 Labels

The following labels are affixed to the STP pump. Read the contents of the labels before operation.

1. STP pump installation warning label

This label describes installation of the STP pump. Install the STP pump according to the precautions. Install the STP pump according to the precautions of Section 3, "INSTALLATION OF THE STP PUMP".



Figure 1 - STP pump installation warning label

2. Hot surface warning label

This label instructs operators so as not to touch the hot surface of the STP pump. The pump and control unit will become high temperature while the STP pump is in operation. This label warns operators so as not to burn hands.



Figure 2 - Hot surface warning label

STP-iXA3306 Series Turbomolecular Pump

3. Heavy product caution label

This label is affixed to the product with a weight of 18 kg or more. Follow the precautions of Section 3.2, "Unpacking" so as not to cause any accident during handling.



Figure 3 - Heavy product caution label

4. High voltage device caution label

The pump and control unit are equipped with a high voltage device. This label warns operators to pay attention to the high voltage device at the maintenance and inspection.



Figure 4 - High voltage device caution label

5. Rotational direction instruction label

This label describes the rotational direction of the STP pump. The STP pump rotates in this direction.



Figure 5 - Rotation instruction label

STP-iXA3306 Series Turbomolecular Pump

1.7 Operation principle of the STP pump

Turbomolecular pump (abbreviated to "STP pump" throughout this manual) is used for high vacuum pumping. It is principally used for manufacture and inspection equipment of semiconductor, flat panel, solar battery.

The STP pump (Figure 6) is configured so that rotor blade (1) and stator blade (2) are aligned alternately in the axial direction. Gas molecules are pumped from the inlet port to the outlet port by the high speed rotation of the rotor.

The STP-iXA3306 series pump is a series of a magnetically-levitated turbomolecular pumps, each with the following features:

1. Oil free
2. Low vibration
3. High reliability
4. Compact size (Integrated control unit)
5. Temperature management system
6. Dust and water protection (STP-iXA3306C/B)

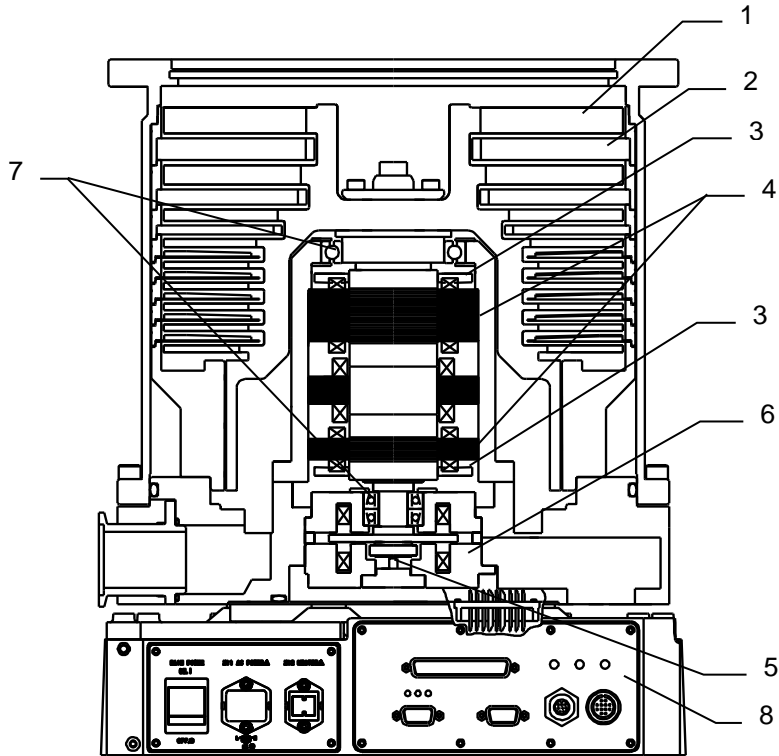

- | | | |
|------------------|-------------------------|-----------------------|
| 1. Rotor blade | 4. Radial electromagnet | 7. Touch down bearing |
| 2. Stator blade | 5. Axial sensor | 8. Control unit |
| 3. Radial sensor | 6. Axial electromagnet | |

Figure 6 - Cross sectional view of the STP pump

1. Oil free

Rotor blade (1) is supported by the magnetic bearing without mechanical contact. Therefore, the STP pump requires no lubrication oil unlike conventional turbomolecular pumps using ball bearings.

2. Low vibration

The magnetic bearing consists of 5 pairs of active magnetic bearings. The rotor is supported in the radial direction by 4 pairs of radial direction active magnetic bearings that consist of radial sensor (3) and radial electromagnet (4). A pair of axial direction active magnetic bearings consists of axial sensor (5) and axial electromagnet (6) to support the rotor in the axial direction. Because the rotor is supported without mechanical contact, it can rotate at low vibration.

3. High reliability

There is no periodic replacement of magnetic bearings unlike conventional turbomolecular pumps using ball bearings because there is no friction. Taking into consideration a breakage of magnetic bearings, touch down bearings (7) have been installed. They do not contact with the rotor during the rated operation. The status of the rotor and magnetic bearing is continuously monitored via circuits detecting rotor displacement, rotational speed and pump temperature. If an abnormality/error occurs, the rotor will stop.

4. Compact size (Integrated control unit)

To save space for installation, the STP pump mounts the control unit (8) that includes the power supply which converts the alternating input to direct current output. In addition, the following circuits are integrated; the magnetic bearing control circuit, the motor drive circuit which drives rotor blade, the supervisor circuit which monitors pump operation status and operates the pump in remote operation mode.

5. Temperature management system

The Temperature Management System (TMS) maintains the temperature of the turbomolecular pump by monitoring the temperature using a thermistor in the base of the turbomolecular pump, and performing the TMS valve and TMS heater ON/OFF control in order to maintain a constant temperature of the STP pump.

Model name: STP-iXA3306CV, STP-iXA3306BV

6. Dust and water protection

The STP pump sealed with the equivalent specification of IP54 standard is protected against dust and water to ensure reliable performance in rough conditions.

IP54 IP: International Protection Code (refer to IEC60529-2001)

- ├── Protection against dust:
 - └── 5: Dust penetration is not prevented altogether, but dust must not enter in sufficient quantities to prevent the equipment from operating satisfactorily, or to impair safety.
- └── Protection against water:
 - └── 4: Water splashes on to the enclosure from any direction must not have any harmful effects.

STP-iXA3306 Series Turbomolecular Pump

1.8 STP pump specification

External appearance, installation and unpacking method differ depending to the STP pump model. Refer to the followings:

**Standard
(corrosion resistant type)**

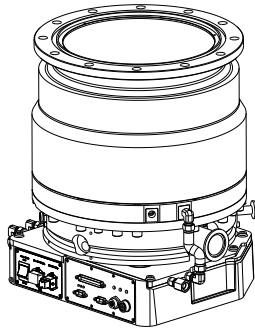

STP-iXA3306C
STP-iXA3306B

**TMS specification
(corrosion resistant type with TMS)**

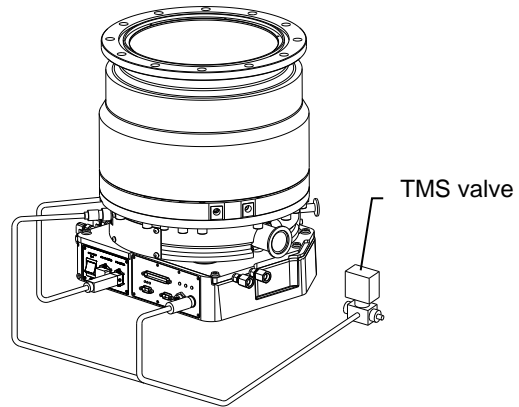

STP-iXA3306CV
STP-iXA3306BV

Naming convention:

- "C" following a pump model name indicates a corrosion resistant^{*1} type.
(e.g. STP-iXA3306C)
- "B" following a pump model name indicates corrosion resistant^{*1} and high-emissivity^{*2} coating type.
(e.g. STP-iXA3306B)
- "V" indicates a TMS^{*3} unit.
(e.g. STP-iXA3306CV)

^{*1} Corrosion resistant: STP pump with anti-corrosive treatment.

^{*2} High-emissivity coating: STP pump with rotor covered with high-emissivity coating.

^{*3} Temperature Management System: TMS maintains the temperature of the turbomolecular pump by monitoring the temperature with the thermistor in the base of the turbomolecular pump, and performing the TMS heater ON/OFF control in order to maintain a constant temperature of the STP pump.

STP-iXA3306 Series Turbomolecular Pump

The display unit iDT-001 is available as an optional accessory with the STP-iXA3306 series. The display unit operates the STP pump, confirms the pump status or sets various settings. (refer to Section 6.2 and the Instruction Manual of the "Display Unit iDT-001".)

Display unit iDT-001

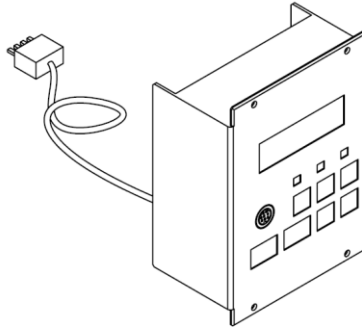



STP-iXA3306 Series Turbomolecular Pump

1

INTRODUCTION

This page intentionally blank

2 TECHNICAL DATA

2.1 STP pump specifications

The values shown below are typical. They are not guaranteed.

Item		STP-iXA3306C(V) / STP-iXA3306B(V)	
Flange size	Inlet port flange	VG250 / ISO250F ICF305 (DN250CF)	VG300 / VG350 ISO320F ICF356 (DN320CF)
	Outlet port flange	KF40	
Pumping speed	N ₂ L/s	2650	3200
	Ar L/s	2300	2800
	H ₂ L/s	2050	2300
Compression ratio	N ₂ , Ar	>10 ⁸	
	H ₂	>2.0×10 ³	
Ultimate pressure	Pa (Torr)	10 ⁻⁷ (10 ⁻⁹) [after baking]	
Allowable backing pressure	Pa (Torr)	266 (2): Water cooling/TMS unit used	
Flow rate of purge gas <N ₂ >	Pa·m ³ /s(SCCM)	8.4×10 ⁻² ±1.7×10 ⁻² (50±10)	
Rated speed	rpm	27,700	
Backup rotational speed *1	rpm	Approximately 5,000	
Starting time	min	≤ 10	
Stopping time	min	≤ 16	
Noise	dB	< 55 (at 27,700 rpm)	
Temperature Management System (TMS)		Available	
Baking temperature	°C	<120	
Lubricating oil		Not necessary	
Installation position		Free	
Cooling method		Water cooling	
Recommended backing-pump	L/min	>1,300	
Mass *2	kg	80	83
Ambient temperature range	°C	0 to 40	
Storage temperature range	°C	-25 to 55	

*1 A backup rotational speed is the lowest rotational speed to which the magnetic bearing can be backed up at a power failure.

*2 Mass is a value of state that the only standard accessory was installed (except the optional accessory).

STP-iXA3306 Series Turbomolecular Pump

2.2 Maximum gas flow-rate

2.2.1 STP-iXA3306C/CV

Cooling water	backing-pump	Gas	Maximum gas flow-rate	
			[Pa·m ³ /s]	[SCCM]
15 to 25 °C	> 1,300 L/min	Ar	2.87	1700
		N ₂	4.05	2400
	> 10,000 L/min	Ar	3.55	2100
		N ₂	6.76	4000
26 to 35 °C	> 1,300 L/min	Ar	2.53	1500
		N ₂	3.72	2200
	> 10,000 L/min	Ar	2.87	1700
		N ₂	6.59	3900

Table 1 - Maximum gas flow-rate (STP-iXA3306C)

Cooling water	backing-pump	Gas	Maximum gas flow-rate		TMS (setting value)
			[Pa·m ³ /s]	[SCCM]	
15 to 25°C	> 1,300 L/min	Ar	2.03	1200	70 °C
		N ₂	3.55	2100	
	> 10,000 L/min	Ar	2.03	1200	
		N ₂	5.07	3000	

Table 2 - Maximum gas flow-rate (STP-iXA3306CV)

*1The maximum gas flow-rate is applicable under conditions that N₂ or Ar gas is vacuumed continuously and the purge gas flow rate $\langle N_2 \rangle 8.4 \times 10^{-2} \pm 1.7 \times 10^{-2}$ Pa·m³/s (50±10 SCCM) is used. It is changed depending on condition. For example, when the gas is exhausted intermittently, the gas more than the maximum gas flow-rate can be exhausted. In this case, contact Edwards.

STP-iXA3306 Series Turbomolecular Pump

2.2.2 STP-iXA3306B/BV

Cooling water	backing-pump	Gas	Maximum gas flow-rate	
			[Pa·m ³ /s]	[SCCM]
15 to 25 °C	> 1,300 L/min	Ar	3.72	2200
		N ₂	4.05	2400
	> 10,000 L/min	Ar	5.24	3100
		N ₂	6.76	4000
26 to 35 °C	> 1,300 L/min	Ar	3.72	2200
		N ₂	4.05	2400
	> 10,000 L/min	Ar	4.90	2900
		N ₂	6.59	3900

Table 3 - Maximum gas flow-rate (STP-iXA3306B)

Cooling water	backing-pump	Gas	Maximum gas flow-rate		TMS (setting value)
			[Pa·m ³ /s]	[SCCM]	
15 to 25°C	> 1,300 L/min	Ar	3.55	2100	70 °C
		N ₂	3.89	2300	
	> 10,000 L/min	Ar	4.23	2500	
		N ₂	6.42	3800	

Table 4 - Maximum gas flow-rate (STP-iXA3306BV)

*1 The maximum gas flow-rate is applicable under conditions that N₂ or Ar gas is vacuumed continuously and the purge gas flow rate <N₂> 8.4×10⁻²±1.7×10⁻² Pa·m³/s (50±10 SCCM) is used. It is changed depending on condition. For example, when the gas is exhausted intermittently, the gas more than the maximum gas flow-rate can be exhausted. In this case, contact Edwards.

2.3 Water cooling use condition

Use cooling water which fulfills the following conditions.

Item		Specification
Port type		Rc 1/4 (Female)
Flow rate	L/min	3
Water temperature	°C	15 to 35 ^{*1}
Water pressure	MPa (kgf/cm ²)	0.3 (3)
Maximum grain size	mm ²	0.03
pH		6.5 to 8.0
Water hardness	mg/L	100
Resistivity	kΩ·cm	4 to 1000
Turbidity	FNU	< 30

^{*1} Maximum gas flow-rate differs according to the cooling water temperature.



STP-iXA3306 Series Turbomolecular Pump

2.4 Control unit

The values shown below are typical. They are not guaranteed.

Item		STP-iXA3306C/B	STP-iXA3306CV/BV
Input voltage	ACV	200 to 240	
Input power	VA	1500 maximum (without TMS unit)	1800 maximum (with TMS unit)
Input frequency	Hz	50/60 ± 2	
Leakage current	mA	2.0 maximum	
Input phase		Single phase	
Main fuse specification	A	10	
Current Ampere Interrupting Capacity (AIC)	A	100 (240V AC 50/60 Hz)	
Pollution degree		2	
Installation category		II	
Motor driving system		3-phase d.c. brushless motor driver	
Output frequency under normal operation	Hz	462 maximum	
Battery for clock function	Specification	Lithium battery (3 V, 130 mAhr)	
	Model	DS9034PCX	
	Maker	MAXIM	
Panel indication LED	POWER	(Green LED)	
	FAILURE	(Red/Orange LED)	
	ROTATION	(Green/Orange LED)	
	Data	(Green LED)	
	Off-Line	(Orange LED)	
	Error	(Red LED)	
Input/Output connector	AC POWER X11	(3 pins)	
	HEATER X12	(2 pins)	
	REMOTE X2	(37 pins)	
	COM1 X3	(9 pins)	
	COM2 X4	(9 pins)	
	STP-LINK X5	(8 pins)	
	OPTION X6	(12 pins)	



STP-iXA3306 Series Turbomolecular Pump

2

TECHNICAL DATA

Item	STP-iXA3306 series
Safety function	Electromagnetic bearing failure detection STP pump overheat detection Motor driver overload detection Power failure detection STP pump overspeed detection Control unit overheat detection Other failure detection

STP-iXA3306 Series Turbomolecular Pump

2.5 External appearance of the STP pump

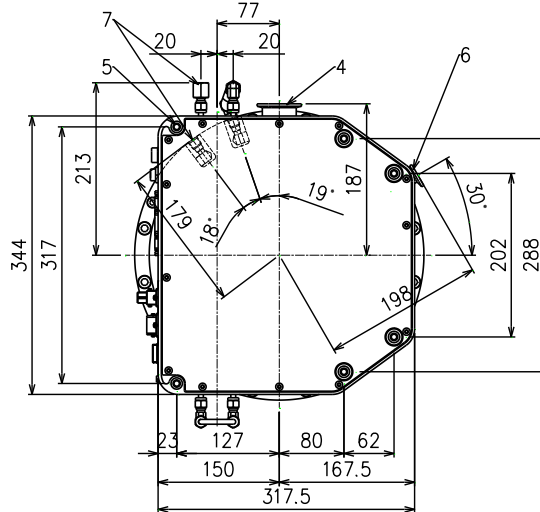
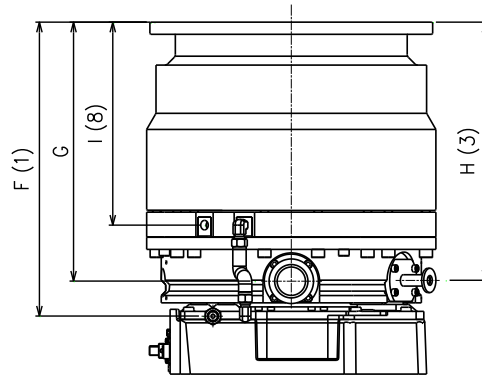
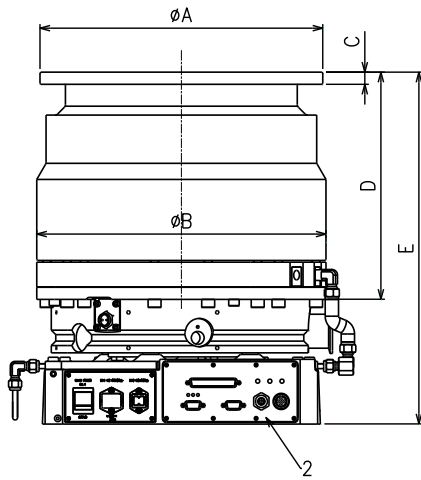

No.	Item	Description
1	Height of water cooling port (IN)	Rc1/4
2	Control unit	
3	Height of the purge port	
4	Outlet port flange	KF40
5	Screw hole for securing the base	6-M16 depth 30
6	Purge port	KF10
7	Cooling water port	2-Rc1/4
8	Height of water cooling port (OUT)	Rc1/4

Inlet port flange	VG250	ISO250F	VG300	VG350	ISO320F	ICF305	VG350	ICF356
ϕA	350	335	400	450	425	305	450	356
ϕB	358	358	358	358	358	358	358	358
C	15	15	18	18	20	28	18	28.5
D	281	281	242	308	242	286	308	281
E	435	435	396	396	396	440	396	435
F	363	363	325	325	325	368	325	364
G	320	320	282	281	282	325	281	321
H	319	319	281	281	281	324	281	320
I	251	251	212	212	212	256	212	251

Figure 7 - External appearance of STP-iXA3306C(V)/iXA3306B(V)

2.6 Label affixing positions

Refer to Section 1.6, "Labels" for the details of the labels 1 to 5.

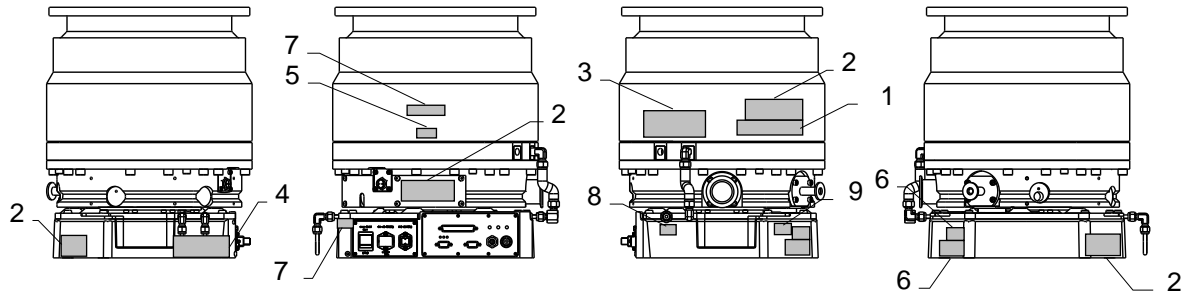

- 1 STP pump installation warning label
- 2 Hot surface warning label
- 3 Heavy product caution label
- 4 High voltage device caution label
- 5 Rotational direction instruction label
- 6 Name plate
- 7 Company logo
- 8 WATER IN label
- 9 WATER OUT label

Figure 8 - Label affixing positions

3 INSTALLATION OF THE STP PUMP

3.1 Precautions before installation

Installation, operation and maintenance must only be executed by personnel who read through this Manual carefully and have the specific skills to perform installation, operation and maintenance of the STP pump.

3.1.1 Operating environment

	<p style="text-align: center;">WARNING</p> <p>To prevent an accident, confirm the characteristics of gases to be used, referring to the Material Safety Data Sheet (MSDS) you obtain from the gas supplier, and, keep MSDS and a safety advice of gas supplier.</p>
---	--

	<p style="text-align: center;">WARNING</p> <p>Take measures according to MSDS to prevent an accident when using toxic, reactive or combustible gases. Dilute the gas to be used with the inert gas controlled if necessary. And, take measures according to MSDS to prevent an accident caused by exhaust gas.</p>
--	---

<p style="text-align: center;">CAUTION</p> <p>Chlorine or fluorine system gases can be used in corrosion resistant pumps. When you use the following gases, contact Edwards:</p> <ul style="list-style-type: none">• Gases including alkaline metals except Li gas.• Gases including Ga, Hg, In, or Sn.• HBr gas. <p>Non-corrosion resistant pump cannot use the above gases including chlorine and fluorine system gases.</p>

STP-iXA3306 Series Turbomolecular Pump

The STP pump should be installed in an area which meets the following requirements:

Ambient temperature	0 to 40 °C (32 to 104 °F)
Ambient relative humidity	30 to 95% (no dew condensing)
Environment	<ul style="list-style-type: none"> • An area free of externally applied mechanical shock. • A place free of a heat source (Keep clear of the heat source or attach a thermal shield plate). • A place free of a strong magnetic field (Range: up to 15 mT (150 G) in the axial direction, and up to 3 mT (30 G) in the radial direction with respect to the rotational axis of the STP pump). • A place free of a strong electric field. • A place free of exposure to radiation. • No discharge of high voltage (more than 500 V) (If more than 500 V is discharged, contact Edwards). • Others: An area free of exposure to direct sunlight, high humidity, dust, salty air, dripping water, explosive or flammable gas, corrosive gas, excessive vibration and sources of electric noise.
STP pump installation equipment conditions	Install the STP pump securely so that foreign materials cannot fall into the STP pump (Ex.: Si wafers or samples are positioned above the STP pump) (To prevent foreign materials from falling into the STP pump, design a shield plate with large conductance).
	<p>Install the STP pump so that the inlet flange of the STP pump not to be exposed to heat source. (Install the heat shield plate so as to prevent the effect by radiation heat)</p> <div style="display: flex; justify-content: space-around;"> <div data-bbox="710 1507 986 1861"> <p>Good example: Heat shield plate</p> </div> <div data-bbox="1086 1507 1362 1861"> <p>Bad example: None</p> </div> </div>

* STP-iXA3306 series is equivalent to the specification of Protection Classification IP54 sealed. This model has protection against dust and water splashed from any direction. Refer to IEC60529-2001 for details.

Table 5 - Environmental requirements for installation

3.1.2 Installation area

Leave enough space for the followings in addition to that for the STP pump: (see Figure 9)

- Space for maintenance and inspection.
- Space for connecting cables.

CAUTION

DO NOT bend the cables excessively and beware of any obstacles when installing the STP pump. In addition, leave enough space to install other cables without bending them excessively.

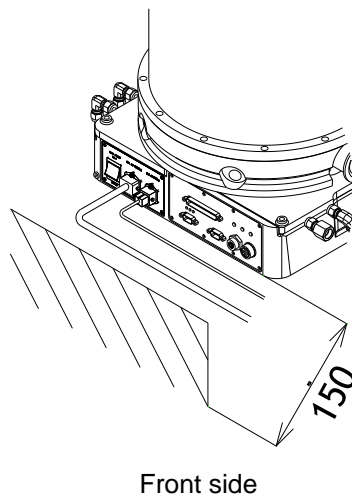

Figure 9 - Space around the STP pump

3.1.3 Bench

A bench must be prepared by the customer to secure the STP pump. The shape and size of the bench differ depending upon the type of STP pump.



WARNING

Obey the safety instructions given below and take note of appropriate precautions. If you do not, you can cause injury to people and damage to equipment.



WARNING

The STP pump is provided with a high-speed rotor. Any internal abnormality/error may result in a jump in rotational torque leading to personal injury or peripheral equipment damage.



WARNING

Design and secure the bench for the STP pump so that it can withstand the maximum torque generated due to the occurrence of an abnormality/error. Refer to Section 3.4.3, "Secure the STP pump" for abnormal torque.

CAUTION

Secure the customer-prepared bench and the vacuum equipment on the floor or peripheral equipment and other equipment in accordance with the customer application. NEVER move them while the STP pump is in operation.

Confirm the dimensions by the external appearance of the STP pump when designing the bench.

The bolt may not be able to be inserted from the lower side of the inlet port according to the shape of the inlet port flange.

Note: When the external appearance of the STP pump is not in the manual, contact Edwards.

3.1.4 Insulation test

CAUTION

The varistor for the power supply line protection is installed in the control unit. DO NOT perform the insulation test with the varistor installed. Doing so may result in product damage to the control unit.

DO NOT perform an insulation test on the control unit. When performing the insulation test on your equipment, ensure that you disconnect the control unit from the equipment that is to be insulation tested, so that the test voltage is not applied to the control unit.

3.2 Unpacking

3.2.1 Unpacking the STP pump

Check outer package for damage and that the delivery note corresponds to the purchase order. If the STP pump is damaged, contact Edwards or their distributor.

Note: It is recommended to keep the packaging materials, such as the corrugated fiberboard container and cushioning material for possible reuse.

	<p>WARNING</p> <p>The STP pumps are heavy products. Observe national laws/regulations, safety standards and manufacturers instructions when lifting the STP pump. Lifting devices must be used when lifting or moving the STP pump.</p>
---	--

The STP pumps are heavy products (Refer to Section 2, "TECHNICAL DATA" for the mass of the STP pump). Use a crane or other appropriate means sufficient enough to withstand the load when lifting the STP pump of 18 kg or more.

Lift the STP pump with an eyebolt or a similar tool that uses the fitting hole attached to the inlet port flange. When lifting the pump, use 2 or more ropes. (see Figure 10)

A crane and eyebolts due to lifting operations should withstand the load of five times or more the weight of the STP pump, and rope should be seven time or more. Use an eyebolt which confirms to ISO03266.

Always lift the STP pump in stable places free of excessive shock or vibration to prevent it from shaking or dropping.

Care should be taken not to scratch the flange of the STP pump. Before installing the STP pump, check that there are no scratches on the surface.

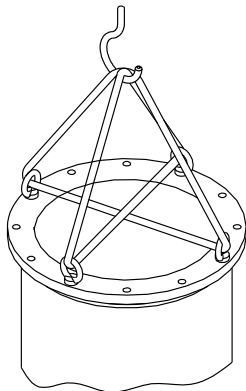

Eyebolt size	Flange type
M8	ICF305, ICF356
M10	ISO250F
M12	VG250, VG300, VG350, ISO320F

Figure 10 - Example of lifting the STP pump

Table 6 - Eyebolt size

STP-iXA3306 Series Turbomolecular Pump

When installing the STP pump horizontally using a crane or other appropriate, support pump casing, pump base, or control unit (see Figure 11). DO NOT apply force on convex parts, such as the outlet port or connectors by ropes. Doing so may cause the pump to fall, or deform and damage the parts.

A crane used for lifting operations should withstand the load of five times or more the weight of the STP pump, and rope should be seven times or more. When lifting the pump, use 2 or more ropes.

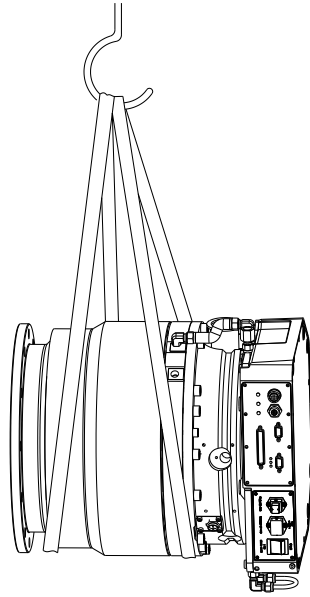

Figure 11 - Example of lifting the STP pump (horizontal positioning)

STP-iXA3306 Series Turbomolecular Pump

Use lifting devices when installing the STP pump under the equipment. A device due to jacking up the STP pump should withstand the load of five times or more the weight of the STP pump.

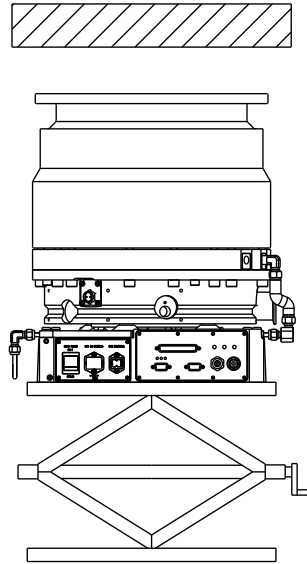

Figure 12 - Jack-up the STP pump

When jacking up the bottom of the control unit, place the STP pump on the table which is larger than base size (Figure 13 [A]) Jacking up the bottom plate (Figure 13 [B]) may deform the plate and cause the breakage of internal parts. A device due to jacking up the STP pump should withstand the load of five times or more the weight of the STP pump.

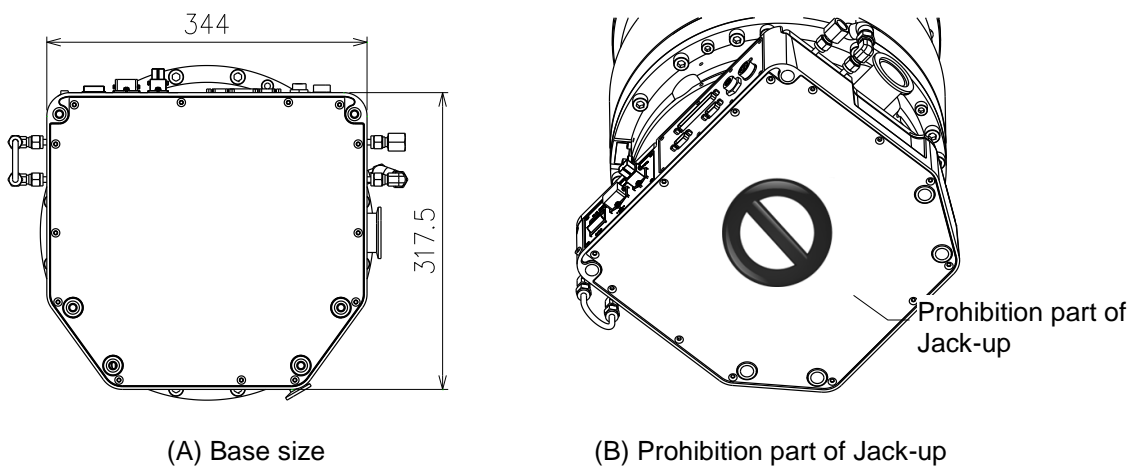

Figure 13 - Control unit bottom face

STP-iXA3306 Series Turbomolecular Pump

DO NOT the grip and pull the cooling water pipe (Figure 14) for cooling water when installing the STP pump.

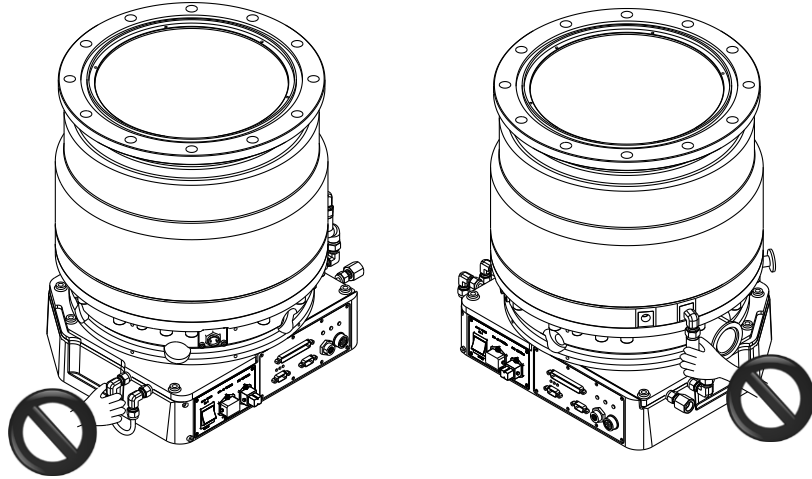

Figure 14 - Prohibited matter

When installing the STP pump to the vacuum equipment in upside-down position, the STP-iXA3306 series can be loft with the eyebolts attached to the screw holes for securing the base. (see Figure 15)

A crane and eyebolts due to lifting operations should withstand the load of five times or more the weight of the STP pump, and rope should be seven time or more. Use an eyebolt which confirms to ISO03266. When lifting the pump, use 2 or more ropes.

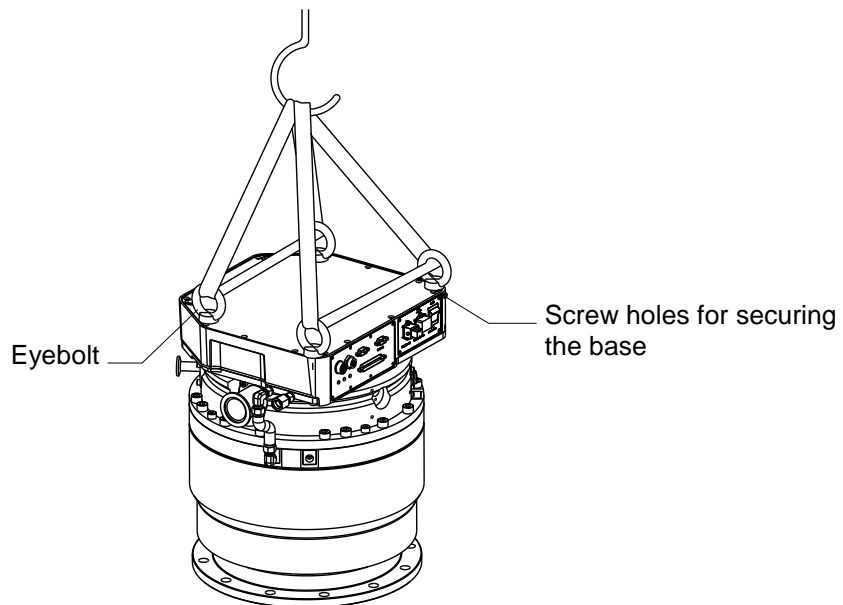

Figure 15 - STP pump with eyebolts

STP-iXA3306 Series Turbomolecular Pump

3.3 Name and function of each part

3.3.1 Name and function of the pump

The STP pump in Figure 16 is a typical pump model. Refer to Section 2, "TECHNICAL DATA".

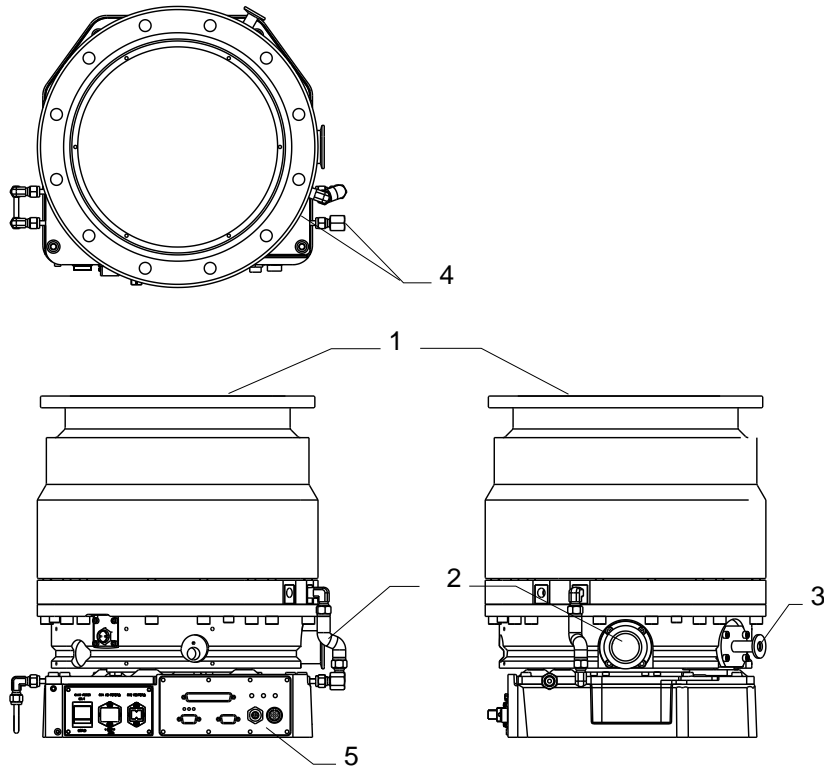

Figure 16 - Configuration of the STP pump

Item	Description	Function
1	Inlet port flange	Connected to the vacuum equipment (at the high vacuum side).
2	Outlet port flange	Connected to the inlet port side of the backing-pump.
3	Purge port	Introduces a purge gas. In order to protect the inside of the STP pump when pumping reactive or corrosive gas, gas including hydrogen.
4	Cooling water port (water cooling unit)	Connected to the STP pump cooling water pipe.
5	Control unit	Contains the electronics that control the pump. Refer to Section 3.3.2, "Name and function of the control unit, for details.

Table 7 - Pump functions

3.3.2 Name and function of the control unit

Figure 17 shows the front panel of the control unit.

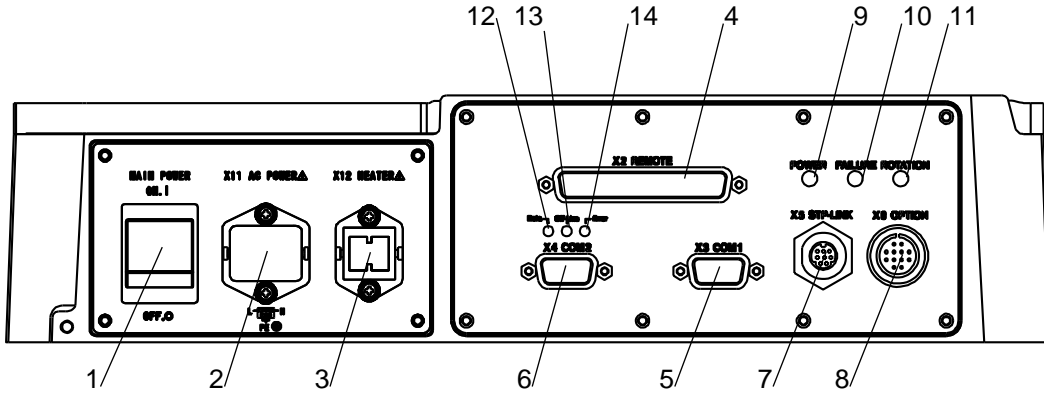



WARNING

A hazardous live voltage may exist at the connectors that are marked with the warning sign . DO NOT touch the connector. Doing so may result in electric shock. When connecting/disconnecting the connector, always power off the primary power (switch the MAIN POWER to "OFF") and isolate (Lockout/Tagout) the electrical energy source, water and gas, and other energy sources on the vacuum equipment.

- | | |
|--|--|
| <p>1 "MAIN POWER" switch</p> <p>2 "AC POWER" connector (X11)</p> <p>3 "HEATER" connector (X12)</p> <p>4 "REMOTE" connector (X2)</p> <p>5 "COM1" connector (X3)</p> <p>6 "COM2" connector (X4)</p> <p>7 "STP-LINK" connector (X5)</p> | <p>8 "OPTION" connector (X6)</p> <p>9 "POWER" LED</p> <p>10 "FAILURE" LED</p> <p>11 "ROTATION" LED</p> <p>12 "Data" LED</p> <p>13 "Off-Line" LED</p> <p>14 "Error" LED</p> |
|--|--|

Figure 17 - Control unit (Front panel)

Note: Refer to Table 9 for front panel functions.



STP-iXA3306 Series Turbomolecular Pump

Item	Description	Function
1	"MAIN POWER" switch	Main power circuit breaker NEVER stop the power supply to the STP pump while the STP pump is in rotation.
2	"AC POWER" connector (X11)	AC input inlet (240 Va.c. maximum) For the AC power cable Input voltage range is between 200 to 240V AC (50/60Hz)
3	"HEATER" connector (X12)	Connect the TMS heater cable before operating the TMS unit (240 Va.c. maximum). Except for TMS unit specification, this connector is not equipped. A blank plate is attached.
4	"REMOTE" connector (X2)	For remote input/output signal in the parallel mode setting. (X2: D-Sub37 pin) See Section 4.9, "Parallel port input/output signal".
5	"COM1" connector (X3)	For RS232 and RS485 (common use) serial communication.(X3: D-Sub9 pin) For the user application. See Section 5, "SERIAL COMMUNICATION PROTOCOL".
6	"COM2" connector (X4)	For RS485 serial communication. (X4: Dsub9 pin) For the Profibus unit (optional accessory). Refer tot the Instruction Manual of the Profibus.
7	"STP-LINK" connector (X5)	For the communication cable of the STP-Link (optional accessory) or the display unit iDT-001 (optional accessory). (X5: STP-LINK) These optional accessories can operate the STP pump, confirm the operation state, or change various settings.
8	"OPTION" connector (X6)	For an optional unit (optional accessory). (X6: 12 pin) TMS valve can be connected.
9	"POWER" LED	(Green LED) Illuminates when 200 to 240 VAC is input to the connector X11 (Power ON state). Refer to Section 4.8, "LED".
10	"FAILURE" LED	(Red/Orange LED) A failure of the STP pump is indicated by the flashing pattern of the red LED. The flashing pattern indicates the failure type. Refer to Section 7, "Safety Functions". A warning of the STP pump is indicated by flashing of the orange LED. The flashing pattern indicates the warning type. Refer to Section 7.2, "WARNING Function".
11	"ROTATION" LED	(Green/Orange LED) The rotational speed is indicated by the flashing pattern of the LED (acceleration state: green, deceleration state: orange). Refer to Section 4.8, "LED".
12	"Data" LED	(Green LED) Functions only when the Profibus (optional accessory) is equipped. Slave (STP pump) is in data exchange as defined by the Profibus standard.

Table 8 - Control unit front panel functions



STP-iXA3306 Series Turbomolecular Pump

Item	Description	Function
13	"Off-Line" LED	(Orange LED) Functions only when the Profibus (optional accessory) is equipped. Slave (STP pump) is not in data exchange as defined by the Profibus standard.
14	"Error" LED	(Red LED) Functions only when the Profibus (optional accessory) is equipped. ON at the same time as Offline LED = Configuration or parameterization error. Flashing at 1 Hz = Invalid address selected.

Table 9 - Control unit front panel functions (continued)

3.4 How to install the STP pump

Install the STP pump to the inside of the vacuum equipment as shown in Figure 18.

	WARNING
<p>An appropriate enclosure or a barrier which cannot be removed without using a tool should be provided to prevent an operator from accessing the connection cables between the STP pump and its connectors provided.</p>	

	WARNING
<p>When installing the STP pump and connecting/disconnecting cables, always power off the primary power (switch the MAIN POWER to "OFF") and isolate (Lockout/Tagout) the electrical energy source, water and gas, and other energy sources on the vacuum equipment. Failure to do so may result in the inadvertent rotation of the STP pump which may result in an accident, an electric shock or damage to equipment.</p> <p>Moreover, an accident caused by water leaks or gas leak may occur.</p>	

CAUTION
<p>Use a lifter or the like when installing the STP pump to the vacuum equipment. Failure to do so might hurt your back or cause injuries due to occurrence of an accident such as fall.</p>

A supportive device such as lifter to installing the STP pump should withstand the load of five times or more the weight of the STP pump.

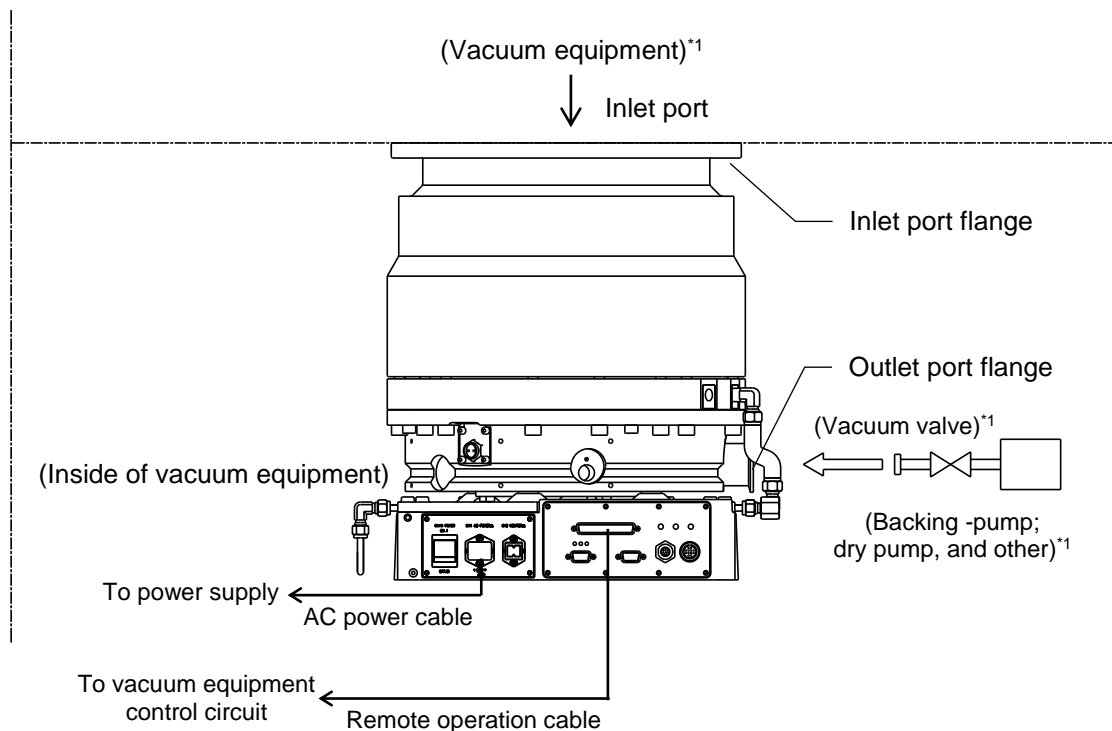

*1 The equipment and part within the parentheses must be prepared by the customer.

Figure 18 - Installation of the STP pump to the vacuum equipment

3.4.1 Cleaning the seal

	<p>WARNING</p> <p>The wipes used to clean the flange of the pump might become hazardous waste depending upon the solvent (alcohol). Dispose of the contaminated wipes appropriately according to the regulations of each national and/or local government.</p>
--	---

	<p>WARNING</p> <p>Obey the safety instructions given below and take note of appropriate precautions when disposing of hazardous waste. If you do not, you can cause injury to people and damage to equipment.</p>
--	--

<p>CAUTION</p> <p>A splinter shield is attached to the inlet port flange to prevent foreign materials from falling into the STP pump. Always leave the splinter shield attached during operation.</p>
--

<p>CAUTION</p> <p>ALWAYS install the STP pump in such a manner that foreign materials cannot easily fall into it. Foreign materials falling into the STP pump through the splinter shield may result in product damage.</p>
--

Inspect the seals of inlet and outlet port flanges for dirt or oil spots before installing the STP pump to the vacuum equipment.

Take the following measures for cleaning the seals:

- Clean off with a pure gas.
- Wipe with proper solvent (such as alcohol).

The splinter shield cannot perfectly prevent foreign materials from falling into the STP pump. ALWAYS install the STP pump in such a manner that foreign materials cannot easily fall into it (for example, Si wafers or samples are positioned above the STP pump). If this is not possible, always attach a shield plate with sufficient conductance above the STP pump to prevent foreign materials from falling into it. Foreign materials falling into the STP pump through the splinter shield may result in product damage.

Take care not to scratch the flange of the STP pump.

Check whether or not there are scratches on the surface, before installing the STP pump. If unsatisfactory, contact Edwards.

STP-iXA3306 Series Turbomolecular Pump

3.4.2 STP pump installation positions

The STP pump can be installed vertically, horizontally, upside-down and/or slanted.

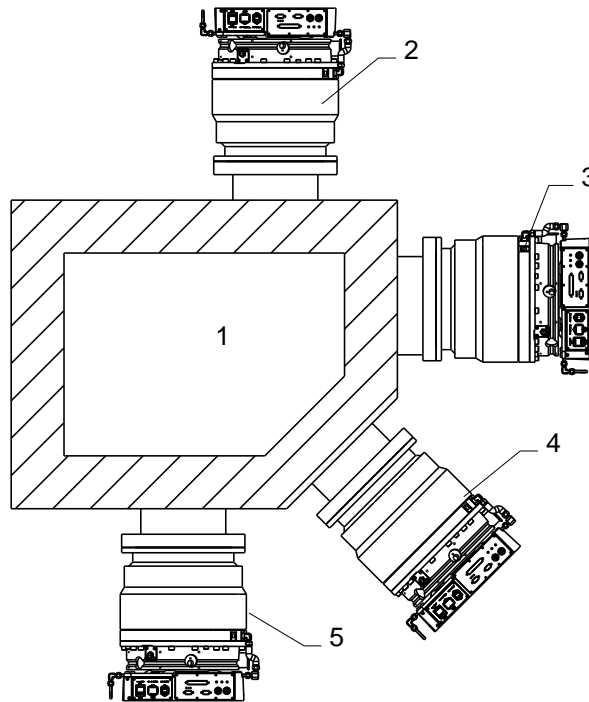

- | | |
|---------------------|-------------|
| 1. Vacuum equipment | 4. Slanted |
| 2. Upside-down | 5. Vertical |
| 3. Horizontal | |

Figure 19 - STP pump installation positions

When installing the STP pump in a horizontal or slanted position, it is recommended to install it so that the direction of the outlet port is on a vertical or horizontal plane in the direction of the gravity. This makes it possible to reduce the load on the magnetic bearing and the heat generated by the STP pump.

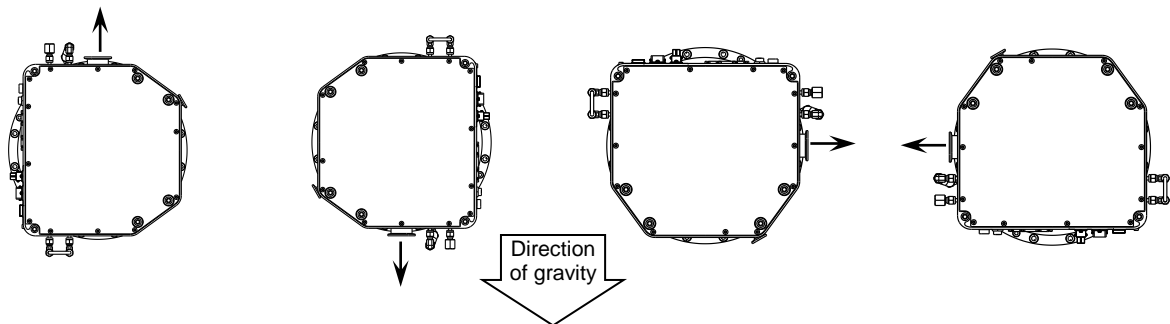

Figure 20 - Positions of the outlet port on the horizontally or slanted installed STP pump

3.4.3 Secure the STP pump



WARNING

The STP pump is provided with a high-speed rotor. Any internal abnormality/error may result in a jump in rotational torque leading to personal injury or peripheral equipment damage.

The STP pump is provided with a high-speed rotor. The worst-case failure may result in a jump in rotational torque leading to personal injury or peripheral equipment damage.

The method of securing the STP pump will depend on the STP pump model and its installation requirements. Secure the STP pump to the vacuum equipment according to the method specified in this manual.

The STP pump is a component system when installing to the semiconductor equipment. Consider the following when installing to the semiconductor equipment.

- Confirm that electric resistance value between the STP pump and vacuum equipment is set to 0.1 Ω or less after securing the STP pump to the vacuum equipment.

The generated torque during a pump failure is called "Destructive torque". Design and secure the mounting for the STP pump so that it can withstand the maximum rotational torque. Refer to Table 11 for torque in pump abnormality.

Bolt size	Tightening torque (Nm)
M8	12
M10	24
M12	42

Table 10 - Tightening torque of bolt

When securing the base, use stainless steel securing bolts with a tensile strength class of 70 or more.

Note: When using any securing method other than that specified in this manual, contact Edwards.

STP-iXA3306 Series Turbomolecular Pump

Pump model		STP-iXA3306C (V) / STP-iXA3306B (V)															
Flange type		ISO250F				VG250				ICF305		ICF356					
Torque reduction mechanism		Equipped (standard)		Not Equipped		Equipped (optional)		Not Equipped (standard)		Not Equipped (standard)		Not Equipped (standard)					
Destructive Torque [kNm]		48.1				48.1				71.2		71.2		71.2			
Base (6 positions) securing		No	Yes	This model is not available				No	Yes	No	Yes	No	Yes	No	Yes		
Recommended bolt	Shape	Standard						Standard		Standard		Standard		Standard		Standard	
	Size	M10	M10					M12	M12	M12	M12	M8	M8	M10	M10		
	Q'ty	12	12					12	12	12	12	32	32	30	30		
	Material ^{*1}	Carbon steel Alloyed steel						Carbon steel Alloyed steel		Carbon steel Alloyed steel	Stainless steel	Carbon steel Alloyed steel	Stainless steel	Stainless steel			
	Strength ^{*1}	12.9 or more						12.9 or more		12.9 or more	12.9 or more	70 or more	70 or more	70 or more			
Special washer	Figure 21		Figure 21		Figure 21		Not necessary		Not necessary		Not necessary						

Pump model		STP-iXA3306C (V) / STP-iXA3306B (V)															
Flange type		ISO320F				VG300				VG350							
Torque reduction mechanism		Equipped (optional)		Not Equipped (standard)		Equipped (optional)		Not Equipped (standard)		Equipped (optional)		Not Equipped (standard)					
Destructive Torque [kNm]		48.1				71.2				48.1				71.2			
Base (6 positions) securing		No	Yes	No	Yes	No	Yes	No	Yes	No	Yes	No	Yes	No	Yes		
Recommended bolt	Shape	Standard		Standard		Standard		Standard		Standard		Standard					
	Size	M12	M12	M12	M12	M12	M12	M12	M12	M12	M12	M12	M12				
	Q'ty	12	12	12	12	12	12	12	12	12	12	12	12				
	Material ^{*1}	Carbon steel Alloyed steel		Carbon steel Alloyed steel	Stainless steel	Carbon steel Alloyed steel		Carbon steel Alloyed steel	Stainless steel	Carbon steel Alloyed steel		Carbon steel Alloyed steel	Stainless steel				
	Strength ^{*1}	12.9 or more		12.9 or more	70 or more	12.9 or more		12.9 or more	70 or more	12.9 or more		12.9 or more	70 or more				
Special washer	Figure 21		Not necessary		Figure 21		Not necessary		Figure 21		Not necessary						

^{*1} Reduced Diameter Shank Bolts

^{*2} Refer to ISO898-1 (JISB 1051), ISO3506 (JISB 1054).

Table 11 - Maximum torque predicted and recommended securing bolt for inlet port flange



STP-iXA3306 Series Turbomolecular Pump

The generated destructive torque depends on the presence of a torque reduction mechanism that can be built into the flange, according to the pump model and flange type. This mechanism, shown in Figure 21, is designed to absorb energy and also buffer the destructive torque.

There are two installation methods for the pump, as shown in Figure 22. Make sure to secure the inlet port flange of the pump with the recommended bolts, as described in Figure 22, according to the installation method used.

Note that special washers will be required if the pump includes the inlet torque reduction mechanism. The washer shape is shown in Figure 21.

CAUTION

Install the flange securing bolts in the proper position with the special square washer shown in Figure 21. Failure to do so may cause abnormal operation of the torque reduction mechanism and damage the pump.

CAUTION

When any internal abnormality/error results in high rotational torque, causing the torque reduction mechanism to operate, the pump may rotate a maximum of 5 degrees around the rotor rotation at axis.

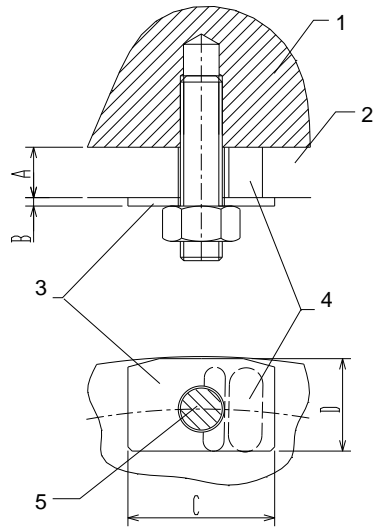

1. Vacuum equipment
2. Inlet port flange
3. Washer
4. Torque reduction mechanism
5. Bolt insert position

	ISO250F	ISO320F	VG250	VG300/VG350
A	15 mm	20 mm	15 mm	18 mm
B	2 mm	2.5 mm	2.5 mm	2.5 mm
C	35 mm	50 mm	50 mm	50 mm
D	22 mm	24 mm	24 mm	24 mm

Figure 21 - Bolt position for securing the flange

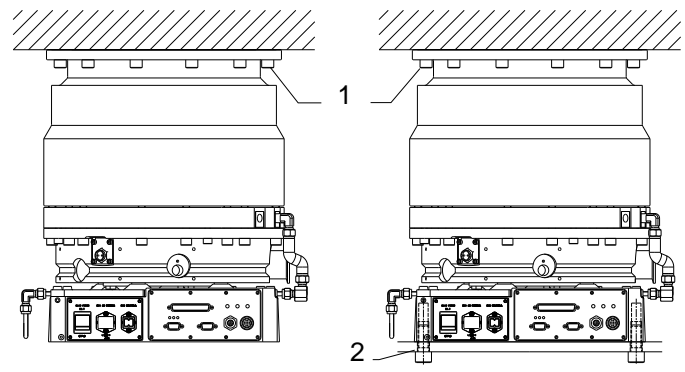

- (i) When the base is not secured
 - (ii) When the base is secured
1. Recommended fitting bolt for flange
 2. Secure the base (legs)

Figure 22 - Methods of securing the STP pump

3.4.4 Legs for securing the base

CAUTION

When securing the base, use stainless steel securing bolts with a tensile strength class is 70 or more.

Figure 23 shows the position of the six screw holes for securing the base of the STP pump.

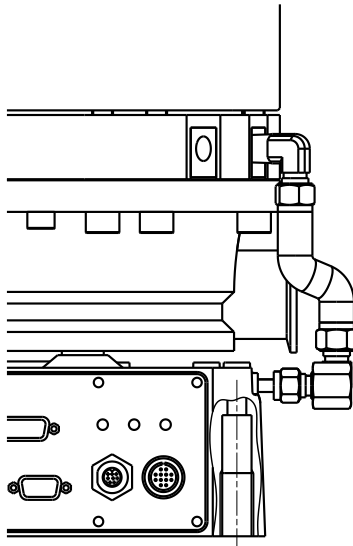

(A) Screw holes for securing the base

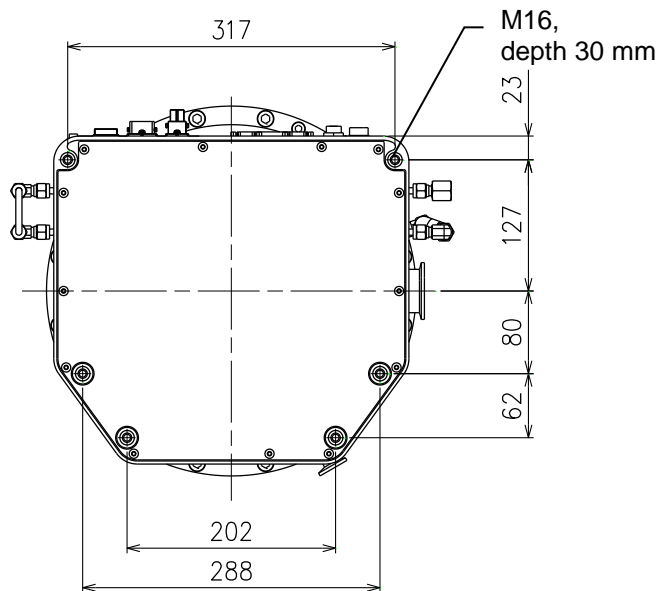

(B) Position of the screw holes for securing the base

Figure 23 - Screw holes for securing the base

3.4.5 Power cable

WARNING

Ensure that the electrical supply cable is suitably protected against earth (ground) faults and that the earth (ground) and "X11 AC POWER" is correctly connected.

CAUTION

The power cable is designed specifically for the STP pump. DO NOT use the power cable with other products.

Connect the power cable securely to prevent any poor or cross connections. DO NOT apply voltages exceeding 1 kV to the input line.

Ensure that the supply voltage is as indicated on the power supply information label.

Connect the power cable to the "X11 AC POWER" on the control unit front panel as shown in Table 12.

Connect the power cable to the main power of the vacuum equipment via a circuit breaker (Rated current 10 A).

Connect the primary power to the UL-recognized terminal block of the vacuum equipment. Secure the terminals with M4-bolts as the other side of the terminals, and cover the terminal block with an appropriate cover. (refer to Figure 25)

Note: The primary power cable is not included. Contact the distributor to purchase.

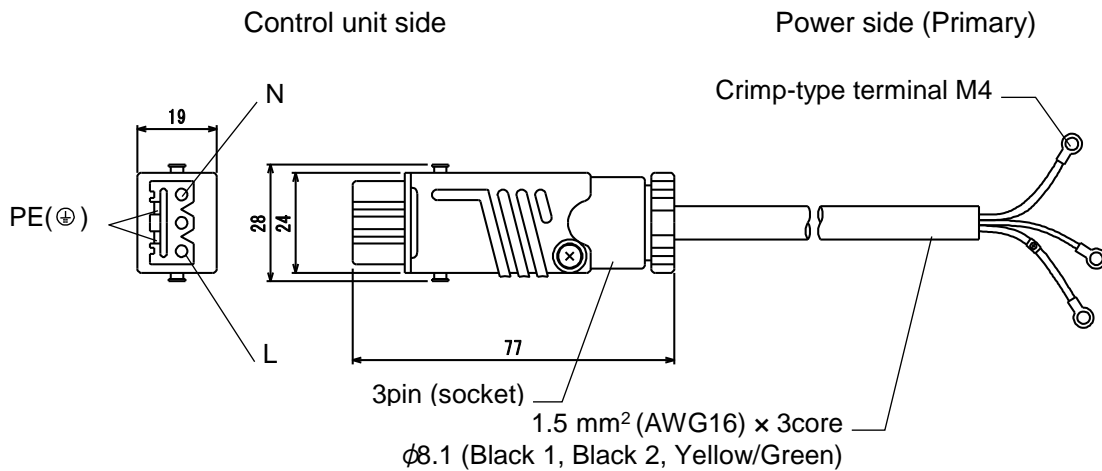
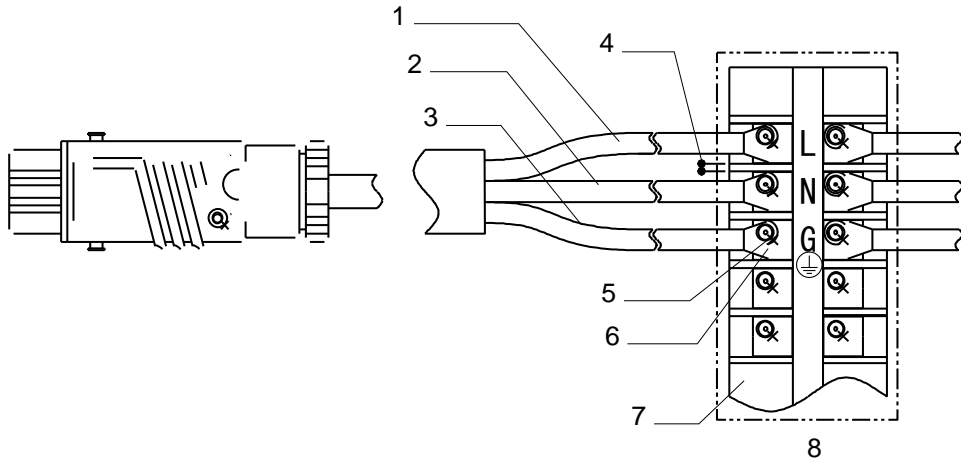

Figure 24 - Power cable

CON1 pin	Cable Colour	Remarks
L	Black 1	Single-phase 200 to 240 V.a.c. 50/60 Hz
N	Black 2	
PE (⊕)	Yellow/Green	Earth (ground)

Table 12 - Power cable



Control unit side

Power side (Primary)

- | | | | |
|---|-----------------------|---|-------------------------------|
| 1 | Black 1 | 5 | M4-bolt (fixing screw) |
| 2 | Black 2 | 6 | Crimp-type terminal (M4) |
| 3 | Yellow/Green | 7 | Cover * ¹ |
| 4 | Clearance min. 1.5 mm | 8 | Terminal block * ² |

*¹ Use material flammability: UL 94V-0

*² Use the UL-recognized terminal block satisfying with the following conditions;

- a) Clearance (between each terminal): 1.5 mm or more
- b) Material flammability: UL 94V-0
- c) The installation category II

Figure 25 - Connecting method of the power cable

3.4.6 How to connect the power cable

	<p style="text-align: center;">WARNING</p> <p>When connecting/disconnecting cables, always power off the primary power (switch the MAIN POWER to "OFF") and isolate (Lockout/Tagout) the electrical energy source, water and gas, and other energy sources on the vacuum equipment. Failure to do so may result in the inadvertent rotation of the STP pump which may result in an accident, an electric shock or damage to equipment. Moreover, an accident caused by water leaks or gas leak may occur.</p>
---	--

CAUTION

Use the power cable that Edwards has specified. The use of other cables may result in product damage.

CAUTION

Confirm the power voltage on the label. Connect the power cable securely to prevent incorrect wiring.

CAUTION

Connect each cable securely with caution, avoiding any obstacles.
DO NOT place heavy objects on the cables or bend them excessively. If any problem occurs in cables, connectors or terminals, the STP pump may not function normally.
DO NOT apply voltage to each connector pin and DO NOT cause any short-circuiting between pins.
Install cables so that personnel are not exposed to risk of tripping or falling.

CAUTION

With each connector align the position of the guide key of the connectors and insert vertically so as not to bend the pins. If a pin is bent, not only may the connector not function normally, but it may make the pins contact, resulting in a malfunction. Lock and securely tighten each connector and screw.

CAUTION

DO NOT apply surge voltage exceeding 1 kV to the input power line. Always ground the power cable to prevent electric shock.



STP-iXA3306 Series Turbomolecular Pump

CAUTION

DO NOT place heavy objects on the cables or bend them excessively. Support each cable so as not to apply direct force to the connectors or terminals. If any problem occurs in cables, connectors or terminals, the STP pump may not function normally. DO NOT apply voltage to each connector pin and DO NOT cause any short-circuiting between pins. Install cables so that personnel are not exposed to risk of tripping or falling.

Connect the power cable to the "X11 AC POWER" on the control unit front panel.

3.5 Precautions of vacuum piping

CAUTION

DO NOT open the STP pump through the flange to atmospheric air while the STP pump is running. If atmospheric air flows into the STP pump, it may not function normally.

Install the valve to isolate purge gas N₂ or cooling water (Lockout/Tagout) at your company.

Depending upon the type of the backing-pump used, atmospheric air may reverse flow into the STP pump when the backing-pump stops.

Attach a vacuum valve to the middle of the piping between the STP pump outlet port flange and the backing-pump, and close the vacuum valve when the backing-pump stops.

Note: Abnormal noise or excessive vibration failure (Disturbance) caused by rotor incline toward outlet port may be generated when performing roughing vacuum depending upon pumping speed of the backing-pump, chamber capacity, or piping length. When the failure is detected, perform the RESET operation.

In order to let the STP pump bring its performance into full play, follow the precautions below:

1. Be careful not to scratch the flange of the STP pump and vacuum equipments. Before installing the STP pump, check whether or not there are scratches on the surface.
2. Use steel or aluminum tubes with a low gas loss to connect the vacuum equipment to the STP pump.
3. Take measures for minimizing leakage. It is also necessary to degrease the tubes as regularly as possible to keep the gas loss as low as possible.
4. There is a recommended backing-pump of pumping speed. (Refer to Section 2.1, "STP pump specifications". However, the pressure at the inlet and outlet ports varies with the flow rate of gas, capacity of the vacuum equipment, length and material of the piping.
Select a backing-pump in accordance with the capacity and starting method (simultaneous starting, starting after generating roughing vacuum) suitable for the vacuum equipment you use.
5. Depending upon the type of the backing-pump used, oil vapour may contaminate the inside of the STP pump. Some oil viscosity could cause a malfunction when there is a strong reverse flow of oil. Take the following measures to ensure the correct flow of oil:
 - Attach a vacuum valve to the middle of the piping between the STP pump outlet port flange and the backing-pump.
 - Attach an absorption trap adjacent to the vacuum valve.

3.5.1 Vacuum piping method

1. Attach the inlet port to the high vacuum side.
(Refer to Section 2.1, "STP pump specification" for maximum working pressure).
2. Attach the outlet port to the inlet port flange of the backing-pump (primary side pump).
(Refer to Section 2.1, "STP pump specification" for allowable backing pressure).

STP-iXA3306 Series Turbomolecular Pump

Note: Maximum flow for water cooled and TMS unit are applicable under the condition listed in Section 2.3, "Water cooling use condition".

3.6 Connecting the purge port

When pumping reactive or corrosive gas, gas including hydrogen, introduce a dry N₂ gas or other gas into the STP pump in order to protect the inside of the STP pump. To isolate (Lockout/Tagout) the purge gas N₂, introduce a dry N₂ gas through the electromagnetic vent. valve, needle valve or similar valve (must be prepared by the customer) from the purge port.

For instructions on how to introduce the purge gas, see Section 4.1.2.

Note: When not introducing the purge gas, close the purge port with the blank flange.

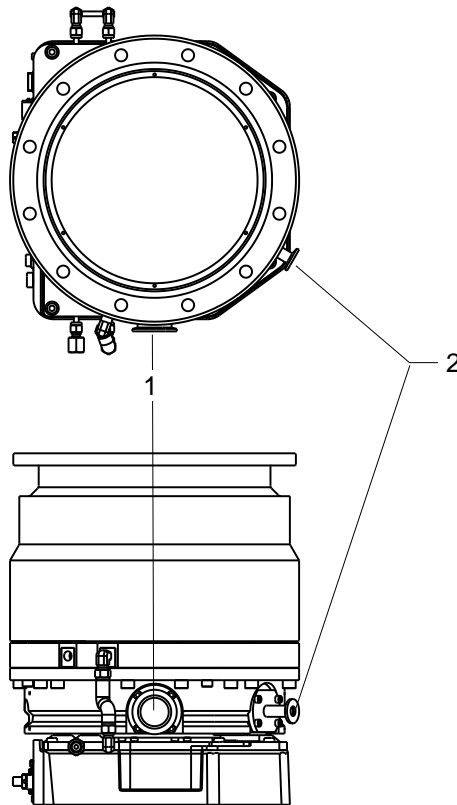

- 1 Outlet port flange 2 Purge port (Dry N₂ gas or other)

Figure 26 - Connecting the purge port

STP-iXA3306 Series Turbomolecular Pump

3.7 Connecting the water cooling pipe

Secure the connection pipe to prevent water leakage and use cooling water under the conditions provided in Section 2.3, "Water cooling use condition". It is recommended to connect the water cooling pipes according to the direction (IN side / OUT side) in Figure 27. Install a secondary containment for liquids or a water leak detector in the place (ex. cooling water ports) where cooling water may leak. Figure 27 shows the position of the cooling water ports.

Install the valve to isolate (Lockout/Tagout) cooling water (Lockout/Tagout) at your company.

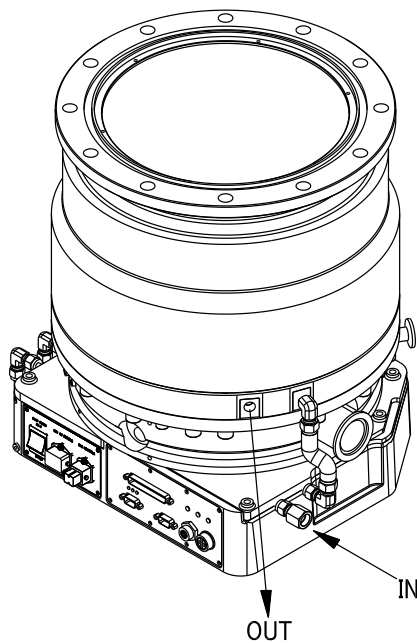

Figure 27 - Positions of the cooling water port

3.8 Attaching a baking heater

	<p style="text-align: center;">WARNING</p> <p>The surfaces of the STP pump and its peripheral equipment will become extremely hot when performing baking. NEVER touch them with bare hands.</p>
--	--

<p style="text-align: center;">CAUTION</p> <p>DO NOT apply excessive force to the cable for the baking heater.</p>

<p style="text-align: center;">CAUTION</p> <p>Wind the baking heater around the surface of the STP pump tightly. If the baking heater is not wound tightly, the loose parts will overheat.</p>

The baking heater is not included in the scope of supply.

When preparing the baking heater at your company, refer to the external appearance on each Instruction Manual of the STP pump before purchasing it.

Install the baking heater near the inlet port flange in the perimeter of the envelope. (see Figure 28)

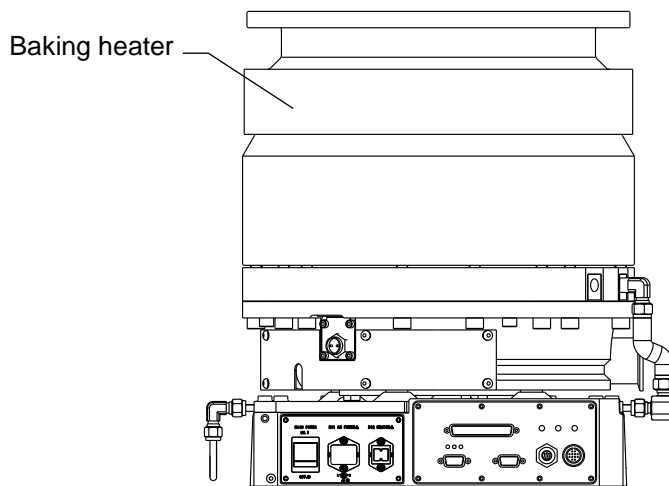

Figure 28 - Baking heater installation position

3.9 Installation of the TMS unit



WARNING

The STP pump operates at high temperatures while the Temperature Management System (TMS) unit is in operation. NEVER touch or remove the heater cover. It causes electric shock or burns. NEVER touch the STP pump and its peripheral equipment while TMS unit are in operation. Operators can burn hands.

The Temperature Management System (TMS) maintains the temperature of the turbomolecular pump by monitoring the temperature with temperature sensor in the base of the turbomolecular pump, and performing the TMS valve and TMS heater ON/OFF control in order to maintain a constant temperature of the STP pump.

The control unit is always water-cooled. Connect the pump and TMS valve according to Figure 30.

CAUTION

DO NOT install the TMS unit in places with high temperature, humidity, noise, vibration, or other unstable environment.

CAUTION

DO NOT apply force to the cables during installation and DO NOT place heavy objects on the cables or bend them excessively.

3.9.1 TMS unit specification

Item	Condition
Temperature control method	Control ON/OFF of the TMS heater and cooling water
Setting temperature °C	Standard type: 70
Failure output	Failure outputs from the STP control unit
TMS heater voltage ACV (Hz)	220 (50/60)
TMS heater capacity W	300
TMS valve voltage DCV	24

Table 13 - TMS unit specification

3.9.2 Configuration of the STP pump with the TMS

Figure 29 shows wiring and piping of two-way valve type. Refer to Figure 30 for wiring and piping of three-way valve type.

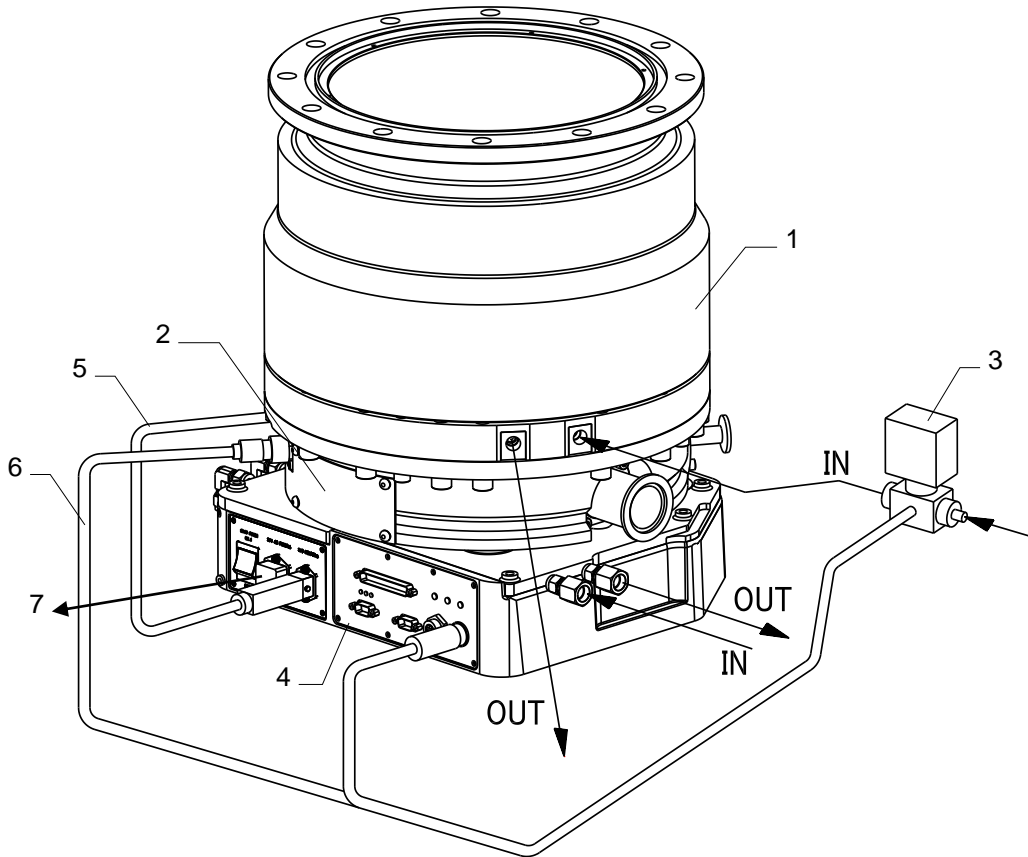

- | | |
|--------------------------|---------------------|
| 1. STP pump | 5. TMS heater cable |
| 2. TMS heater (Built-in) | 6. TMS valve cable |
| 3. TMS valve | 7. Power cable |
| 4. Control unit | |

Figure 29 - Configuration of the TMS

3.9.3 TMS heater

The TMS heater heats the base of the STP pump. It's fitted with the STP pump at the factory. A fuse is set in the TMS heater cable of the STP-iXA3306 series.

3.9.4 Connecting the TMS heater cable

Insert the TMS heater cable into the connector "X12 HEATER" connector of the control unit. (see Figure 17, "Control unit (Front panel)" for the position of the connector X12.)

3.9.5 TMS valve

The TMS valve controls the cooling water in order to maintain a constant temperature inside the STP pump. The shape of the TMS valve varies according to specifications.

3.9.6 Connecting the pump and TMS valve

The control unit is always water-cooled. For (A) Two-way valve type and (B) Three-way valve type in Figure 30, two water supply lines are required for ON/OFF valve control.

Connect the pump and TMS valve according to Figure 30.

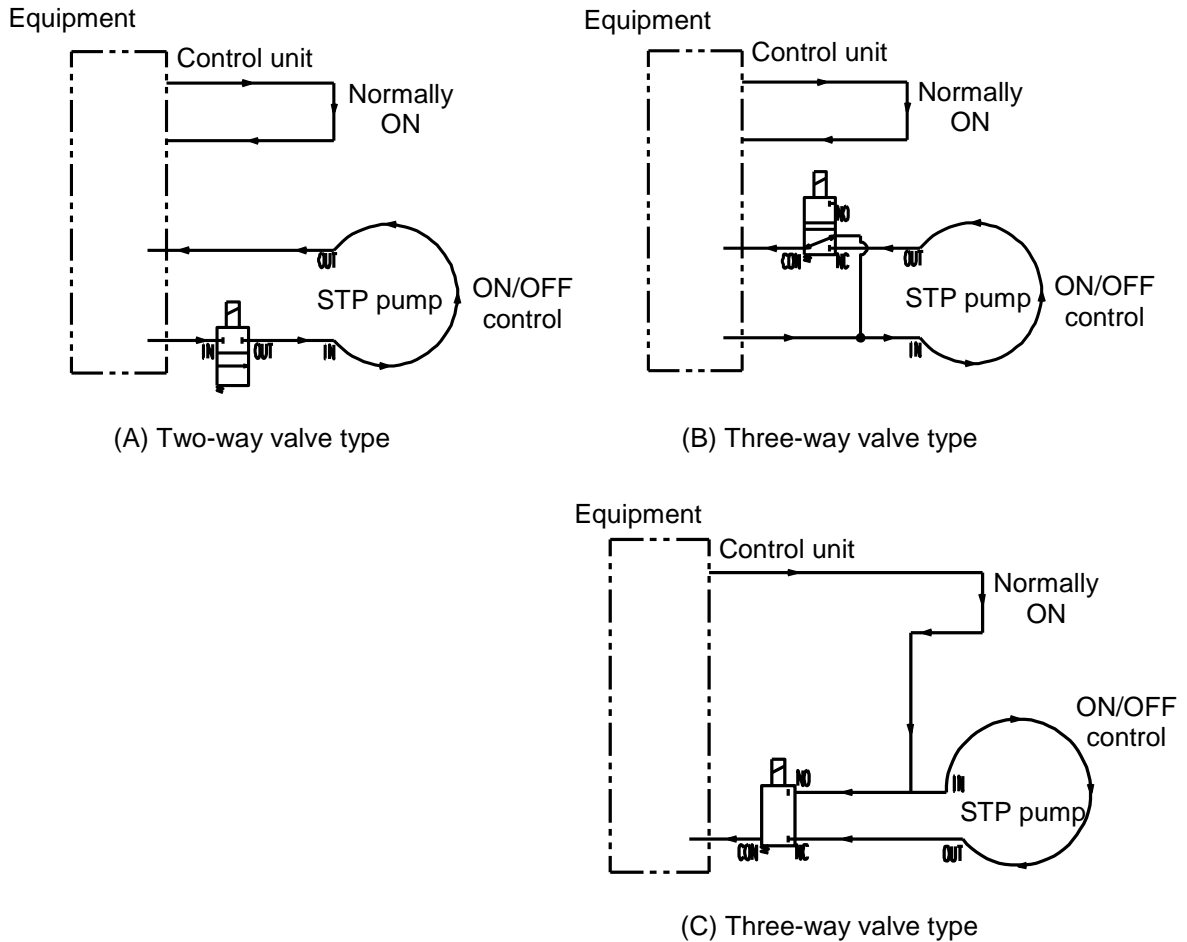

Figure 30 - TMS valve connection

Use cooling water which fulfils the conditions in Section 2.3, "Water cooling use condition".

Note: When the two-way valve is closed, cooling water circulating whole device will stop.

Note: Procure and connect the cooling water pipe and affix the electromagnetic cooling water valve at your site. The diameter of the valve is Rc1/4.

3.10 Connecting to semiconductor equipment

The STP pump is a component system when installing to the semiconductor equipment. Consider the following when designing the semiconductor equipment.

3.10.1 Connecting to power

The STP pump receives its power from the semiconductor equipment electrical distribution system via a circuit breaker (Rated current 10 A).

Electrical energy isolation (Lockout/Tagout) is achieved by opening the main disconnect device or circuit breaker of the semiconductor equipment, thereby removing power from the STP pump.

Provide the equipment with the main disconnect or circuit breaker devices for at least 10,000 A_{rms} symmetrical amperes interrupting capacity (AIC).

3.10.2 Emergency off circuit (EMO circuit)

Activation of EMO circuit of the equipment will interrupt electrical power from the STP pump.

When the power is shut off, the STP pump performs the same as a power failure. (After backup operation of a power failure, the rotor lands on the touch down bearing)

Consider the following when establishing the EMO circuit.

CAUTION

Unite the exhaust gas system to prevent atmosphere from being introduced into the STP pump when the EMO circuit operates (example: shut the valve). When atmosphere is introduced into the STP pump, the touch down bearing may not operate normally.

CAUTION

The STP pump rotates for a while after the EMO circuit shuts off the power. Perform a recovery operation after the STP pump has stopped completely.

CAUTION

Before performing the operation check of the EMO circuit with regular maintenance, stop the STP pump to prevent damage to the touch down bearing.

Note: Procure the main disconnect device and the EMO circuit at your company. Use the main disconnect device which is lockable only in the de-energised position. Locate the main disconnect device and the EMO button in the place where personnel are readily accessible and are not exposed to any hazards during operation.



STP-iXA3306 Series Turbomolecular Pump

3

INSTALLATION

This page intentionally blank

4 OPERATION

4.1 Gas pumping, cooling and baking the STP pump

Installation, operation and maintenance must only be executed by personnel who read through this Manual carefully and have the specific skills to perform installation, operation and maintenance of the STP pump.

4.1.1 Gas pumping

	<p>WARNING</p> <p>To prevent an accident, confirm the characteristics of gases to be used, referring to the Material Safety Data Sheet (MSDS) you obtain from the gas supplier, and, keep MSDS and a safety advice of gas supplier.</p>
--	--

	<p>WARNING</p> <p>When using pyrophoric gas, keep MSDS and a safety advice of gas supplier.</p>
--	--

	<p>WARNING</p> <p>When pumping gases, they may remain in the STP pump. Introduce a purge gas and then exhaust all gases. Residual gases can cause an accident if/when the pump is removed. Take measures according to MSDS to prevent an accident when using toxic, reactive or combustible gases.</p>
--	---

<p>CAUTION</p> <p>Chlorine or fluorine system gases can be used in corrosion resistant pumps. When you use the following gases, contact Edwards:</p> <ul style="list-style-type: none">• Gases including alkaline metals except Li gas.• Gases including Ga, Hg, In, or Sn.• HBr gas. <p>Non-corrosion resistant pump cannot use the above gases including chlorine and fluorine system gases.</p>	
---	--

<p>CAUTION</p> <p>Cool the STP pump to prevent the STP pump from overheating when pumping gases. Install cables so that personnel are not exposed to risk of tripping or falling.</p>	
--	--

4.1.2 How to introduce a purge gas

CAUTION

When pumping reactive or corrosive gas, gas including hydrogen, introduce a purge gas to protect the inside of the STP pump. Not to do so may result in product damage.

Connect a needle valve or a similar part to the purge port and introduce a dry N₂ gas or other gas to perform a gas purge (see Section 3.10, "Connecting the purge port").

CAUTION

Refer to Section 2.1, "STP pump specification" for the specification of each pump for the proper amount of the gas purge to introduce.

High-pressure at the inlet port may result in a noise. This is no abnormality/error.

4.2 Cooling the STP pump

When pumping gases or performing baking, always cool the STP pump.

Also, when performing baking, always cool the STP pump.

If the TMS unit is used, cool the STP pump with the method specified for the TMS unit.

4.2.1 Water-cooling method

The following precautionary procedures will need to be addressed:

- Connect the connecting hoses correctly to prevent from water leak. Refer to Section 2, "TECHNICAL DATA" for the TMS unit condition.
- Use clean water as much as possible. Cooling water containing foreign materials may corrode or clog the cooling water pipe. When the cooling system is clogged with foreign materials, clogs may possibly be removed by feeding cooling water reversibly.
- When the STP pump is not to be used for a long period of time or it is to be moved after use, introduce compressed air from one side of the cooling water port so that no water will remain inside.
- When the STP pump is overheated due to shortage or suspension of water, the protective function detects the overheated condition in the STP pump and stops the STP pump. As a further safety procedure, attach a flow switch to the cooling water exit so that the STP pump stops if abnormal cooling water flow occurs (A flow switch is available on the market).
- The joint for water-cooling unit is made of stainless steel. To prevent corrosion, connect the stainless steel joint.

Note: Refer to Section 2.3, "Condition for the water-cooling unit" for the water-cooling unit.

4.3 Baking the STP pump



WARNING

The surfaces of the STP pump and its peripheral equipment will become extremely hot. Never touch them with bare hands.

CAUTION

The TMS unit and the baking heater cannot be used together at the same time.

To attain a less pressure in a shorter time and reduce the exhaust time, bake the vacuum equipment and STP pump.

When baking the STP pump, always cool it to prevent overheating.

Start baking after cooling is started.

Set the temperature of the baking heater to 120 °C or less.

DO NOT introduce gases during baking, or this will prevent overheating.

To exhaust the gas discharged from the vacuum equipment and the inner wall of the STP pump, run the STP pump during baking.

4.4 Before starting the STP pump

CAUTION

NEVER connect or disconnect any cables while the power is ON. NEVER turn the primary power OFF (turn the MAIN POWER "OFF") while the STP pump is in rotation. DO NOT release the inlet port flange or outlet port flange into the atmosphere while the STP pump is rotating.

4.4.1 Confirmation before starting

After completing installation, piping, leakage test of the STP pump, and wiring of the power cables, the STP pump is ready for start.

1. Ensure the STP pump is installed correctly (refer to Section 3).
2. Ensure the correct supply voltage is applied.
3. Ensure all cables are securely connected and locked.

4.4.2 Confirmation of vacuum system

1. Starting backing-pump

Start the backing-pump before or simultaneously with the start of the STP pump. Open the vacuum valve located at the outlet port flange side after starting the backing-pump.

Note: DO NOT open the vacuum valve without operating the backing-pump. Depending upon the type of the backing-pump, doing so may cause a reverse flow of oil, which could contaminate the inside of the STP pump.

Note: Avoid frequent start/stop operations as this may cause the STP pump to overheat.

2. Stop backing-pump

CAUTION

DO NOT stop the backing-pump without closing the vacuum valve. Depending upon the type of the backing-pump, doing so could cause a reverse flow of atmospheric air into the STP pump, which may result in a malfunction.

Close the vacuum valve located at the outlet port flange side just before or after stopping the STP pump. After closing the valve, stop the backing-pump.

Note: DO NOT stop the backing-pump without closing the vacuum valve. Depending upon the type of the backing-pump, doing so could cause a reverse flow of oil, which could contaminate the inside of the pump.



STP-iXA3306 Series Turbomolecular Pump

4.5 Powering ON

Turn "ON" the "MAIN POWER" switch on the control unit. If no error is found, the magnetic bearing functions and the rotor levitates (POWER ON state). The "POWER" LED illuminates in green (Levitation state).

4.6 Pump operation

4.6.1 Input operation port setting

Set the hardware which operates the STP pump before the operation. The STP pump is equipped with the parallel port (X2 REMOTE connector), serial port COM1 (X3 COM1 connector) as standard hardware for the operation. The STP-Link (optional accessory) or the display unit iDT-001 (optional accessory) can operate the STP pump via the serial port COM3 (X5 STP-Link connector).

When setting the input operation port to the parallel port, refer to Section 4.9, "Parallel port input/output signal". When setting to a serial port, refer to Section 5, "Serial Communication Protocol" for information and methods.

The method of operation with the parallel port (X2 REMOTE connector) is shown below. Following it after reading through Section 4.9, "Parallel port input/output signal". When operating the STP pump via serial communication, refer to Section 5, "Serial Communication protocol".

When operating the STP pump via the STP-Link (optional accessory) or the display unit iDT-001 (optional accessory), refer to each Instruction Manual.

4.6.2 Starting/stopping the STP pump

There are two methods for the starting/stopping operation with the parallel port. Use one of them.

1. Contact input

Open the circuit between (19)-(37).

Method	Starting the pump	Stopping the pump
1	1) Short the circuit between (1)-(21). 2) Short the circuit between (3)-(21) for 0.3 seconds or more. However, when inputting this signal simultaneously with switching "ON" the STP pump, short the circuit between (3)-(21) for 10 seconds or more.	Open the circuit between (1)-(21).
2	Short the circuit between (1)-(3). In this case, (21) is not used.	Open the circuit between (1)-(3).

Table 14 - Starting/stopping the STP pump using contact input (X2 REMOTE)

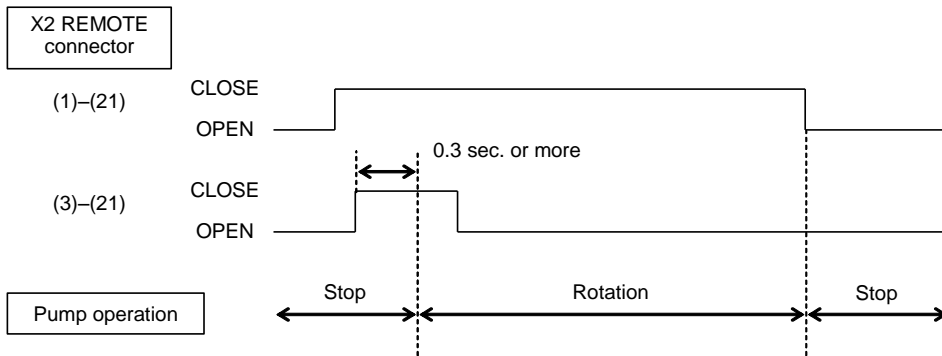

Figure 31 - Pump operation method 1 (contact input)

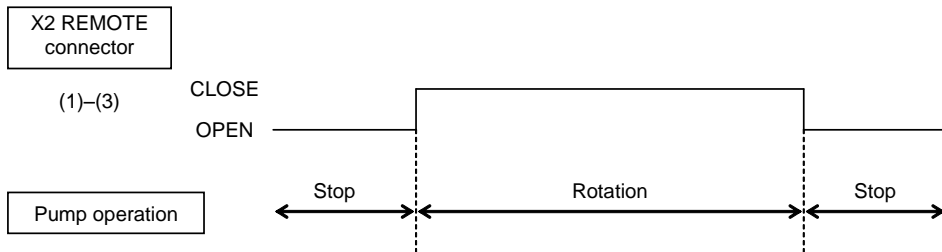

Figure 32 - Pump operation method 2 (contact input)

2. Voltage input

Short the circuit between (19)-(37).

Method	Starting the pump	Stopping the pump
1	1) Supply 12 to 24 VDC to the circuit between (21)-(1). 2) Supply 12 to 24 VDC to the circuit between (3)-(1) for 0.3 seconds or more. However, when inputting this signal simultaneously with switching "ON" the STP pump, supply 12 to 24 VDC to the circuit between (3)-(1) for 10 seconds or more. Connect the (1) pin to 0 V of 12 to 24 VDC.	Shutoff the circuit between (21)-(1).
2	Supply 12 to 24 VDC to the circuit between (3)-(1). In this case, (21) is not used.	Shutoff the circuit between (3)-(1).

Table 15 - Starting/stopping the STP pump using voltage input (X2 REMOTE) (voltage input)

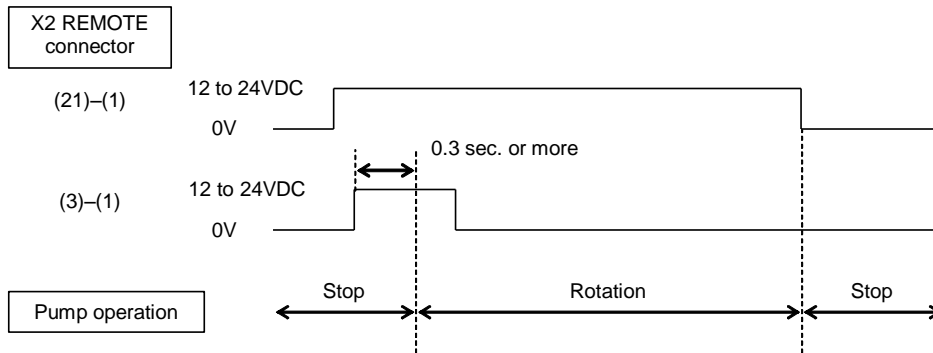

Figure 33 - Pump operation method 1 (voltage input)

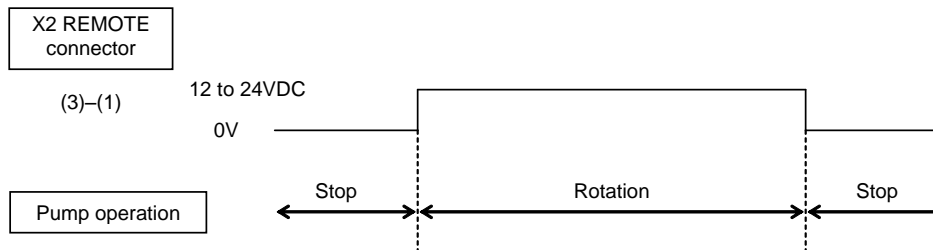

Figure 34 - Pump operation method 2 (voltage input)

4.7 How to start/stop the STP pump

4.7.1 Starting the STP pump after stopping

Perform the start operation shown in Section 4.6.2, "Starting/stopping the STP pump". The STP pump can be reaccelerated even while it is stopping.

4.7.2 Starting the STP pump after a safety function operates

A safety function operates when an abnormality/error occurs in the STP pump or peripheral equipment. To restart the STP pump, remove the cause of the abnormality/error after the "ROTATION" LED extinguishes, and perform the operation shown in Table 16. The "FAILURE" LED extinguishes and the safety function is released (RESET operation). Then, restart the STP pump. For the safety functions and troubleshooting, see Section 7, "Safety Functions".

Method	Reset operation
1	Short the circuit between (1)-(22) for 0.3 seconds or more. When using voltage input, supply 12 to 24 VDC to the circuit between (22)-(1) for 0.3 seconds or more. Connect the (1) pin to 0V of 12 to 24VDC.

Table 16 - Reset Operation (X2 REMOTE)

4.7.3 Powering OFF

Turn "OFF" the STP pump when the "ROTATION" LED is OFF. The magnetic bearing stops, the rotor lands, and the "POWER" LED extinguishes (POWER OFF state).

4.8 LED

Three LEDs indicate the pump's operational state.

LED	Power on state (Levitation state)	Acceleration state	Deceleration state	Warning/ Failure state
POWER (green)	Steady green	Steady green	Steady green	Steady green (OFF only at power failure)
ROTATION (green/orange)	Extinguishes	Green 2,000 rpm or less: 1 flash 2,000 to 10,000 rpm: 2 flashes 10,000 to 20,000 rpm: 3 flashes 20,000 to 24,500 rpm: Continuous flash 24,500 to 27,700 rpm or under normal operation: Steady (see Figure 35)	Orange	See left
FAILURE (orange/red)	<ul style="list-style-type: none"> Warning state: Flashing orange (The flashing pattern of the LED indicates the type of warning. See Section 7, "WARNING Function") Failure state: Flashing or steady red (The flashing pattern of the LED indicates the type of failure. See Section 7, "WARNING Function") 			

Table 17 - LED Indications for each state

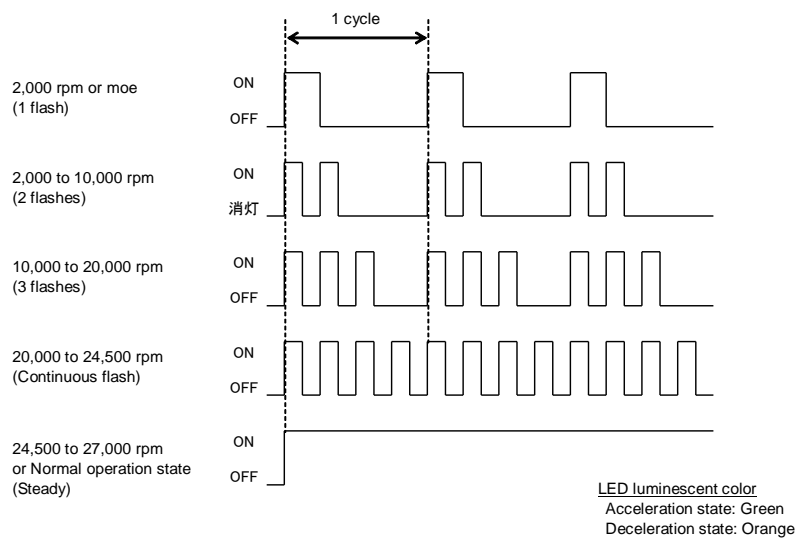

Figure 35 - "ROTATION" LED Indication

4.9 Parallel port input/output signal

The remote input/output signal connector "X2 REMOTE" is used for input/output remote signals (see Figure 36). This connector is of D-Sub (37 pins, socket type) type. The screw for connector is M2.6.

Note: The connector (pin type) is not included. Procure control equipment at your company.

Note: It is recommended to use a remote cable with shield type, and connect both terminals to the ground.

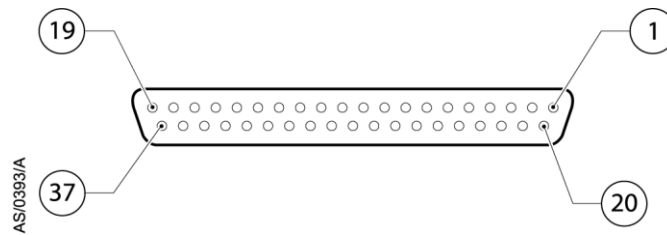

Figure 36 - X2 REMOTE connector

4.9.1 Input signal pins

Choose contact input signal or voltage input signal. When using contact input, refer to Table 18, Table 19, and Figure 37. When using voltage input, refer to Table 20, Table 21, and Figure 38. The input signal pins function only when the input operation port is set to the parallel port.

Two abbreviations are used in Table 18, Table 19 and Figure 37:

- COM: Common Pin
- IN: Input Pin

Pin	Description
	<p>Pins for choosing the input signal. When using the contact input, open the circuits between (19)-(37).</p>
	<p>Pins for inputting the START signal. The following two methods are available: 1) Short the circuits between (1)-(21). Then, short the circuits between (3)-(21) for 0.3 seconds or more. However, when inputting this START signal simultaneously with switching "ON" the STP pump, continue to short these pins for 10 seconds or more.</p>
	<p>2) Short the circuits between (1)-(3). In this case, (21) is not used.</p>
	<p>Pins for inputting the STOP signal. 1) When 1) above is used to start the STP pump, open the circuits between (1)-(21) to stop the STP pump.</p>
	<p>2) When 2) above is used to start the STP pump, open the circuits between (1)-(3) to stop the STP pump.</p>
	<p>Pins for inputting the RESET signal. When a safety function operates, remove the cause of the abnormality/error after confirming the STP pump has stopped. When the cause of the abnormality/error is removed, short the circuits between (1)-(22) for 0.3 seconds or more to reset the failure signal (The "FAILURE" LED extinguishes).</p>
	<p>Pins for inputting the rotation INHIBIT signal. The input pins are valid even when input operation port is set to serial port. When the pins (1)-(5) are opened, the STP pump does not rotate despite the presence of a start signal. When these pins are opened while the pump is operating, the pump will stop (see Section 4.9.3). When using this function, short the circuits between (1)-(2) of the rotation INHIBIT enable signal.</p>

Table 18 - X2 REMOTE input signal pins



Pin	Description
<p>(1) (4)</p> 	<p>Pins for inputting the input operation port select signal. When the pins between (1)-(4) are short-circuited, the input operation port will be set to the parallel port automatically, and the input operation via the serial port is disabled. When the pins between (1)-(4) are opened, a parallel port or any of three serial ports from COM1 to COM3 can be selected in the input operation port (see Section 5).</p>
<p>(1) (2)</p> 	<p>Pins for inputting the rotation INHIBIT enable signal. The input pins are valid even when input operation port is set to serial port. When the pins between (1)-(2) are short-circuited, the rotation INHIBIT signal input is enabled.</p>
<p>(1) (23)</p> 	<p>Pins for option signal input. When pins (1)-(23) are set from open state to close, rotational speed will be second speed in the normal state. When pins (1)-(23) are set from close state to open, rotational speed will be normal speed in the normal state. When using this function, set the second speed option to the "ENABLE" from serial communication port or STP-Link. (see Section 5.4)</p>

Table 19 - X2 REMOTE input signal pins (continued)

STP-iXA3306 Series Turbomolecular Pump

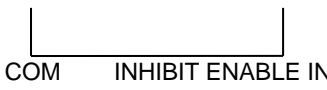

A. In case of Start 1) B. In case of Start 2)

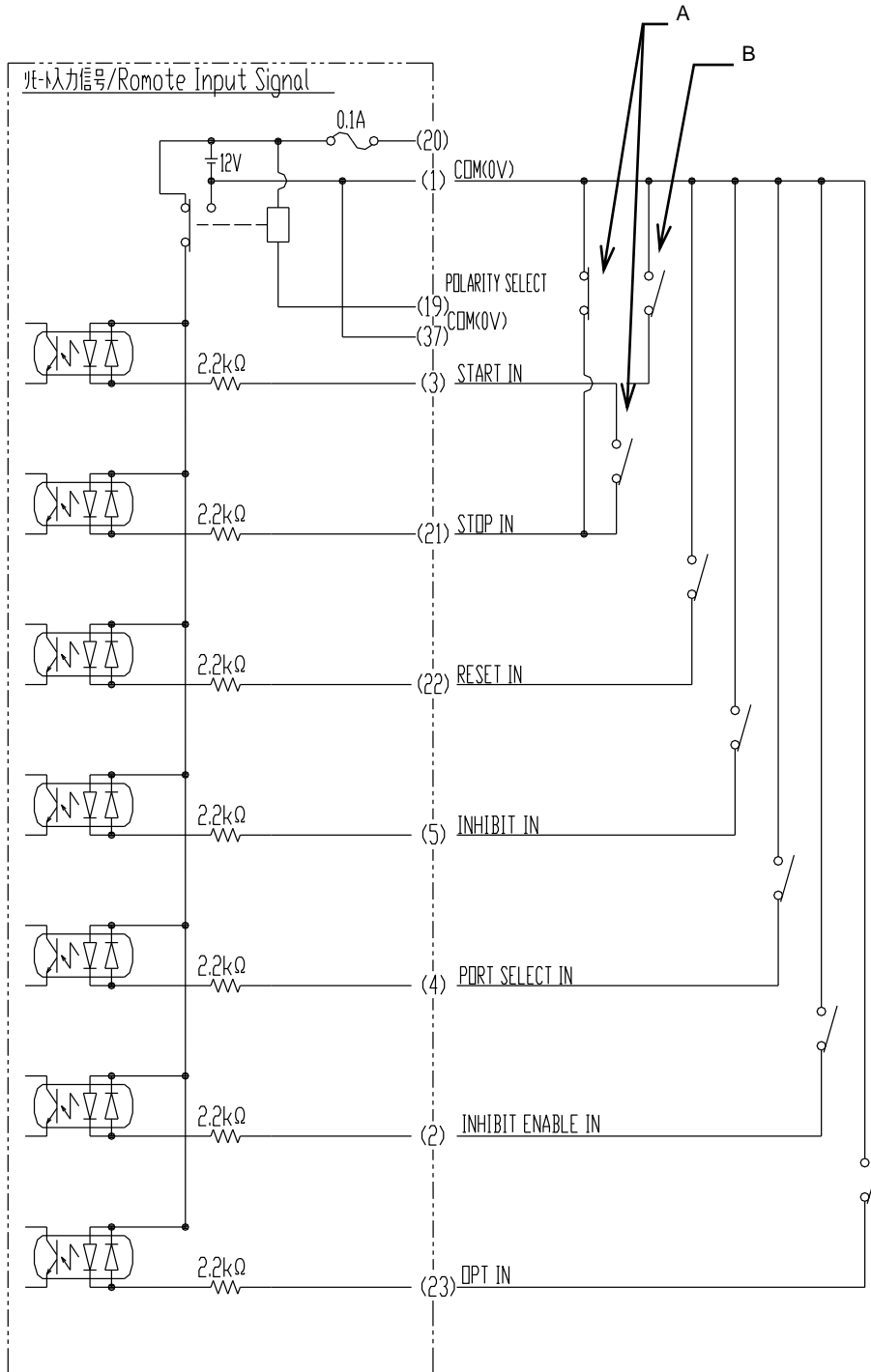
Figure 37 - X2 REMOTE input signal pins (contact input)

Note: COM pins (1, 37 pin) are isolated from the frame ground.

Note: The input current of remote input signal is approx. 5 mA. Make sure the minimum applicable load of the relay contact when the remote operation with the relay.

Pin	Description
	<p>Pins for choosing the input signal. When using voltage input, short the circuits between (19)-(37).</p> <p>Pins for inputting the START signal. The following two methods are available:</p> <ol style="list-style-type: none"> 1) Supply 12 to 24 VDC to the circuits between (21)-(1). Then, supply 12 to 24 VDC to the circuits between (3)-(1) for 0.3 seconds or more. However, when inputting this START signal simultaneously with switching "ON" the STP pump, continue to supply voltage to these pins for 10 seconds or more.
	<ol style="list-style-type: none"> 2) Supply 12 to 24 VDC to the circuits between (3)-(1). In this case, (21) is not used.
	<p>Pins for inputting the STOP signal.</p> <ol style="list-style-type: none"> 1) When 1) above is used to start the STP pump, shutoff voltage to the circuits between (21)-(1) to stop the STP pump.
	<ol style="list-style-type: none"> 2) When 2) above is used to start the STP pump, shutoff voltage the circuits between (3)-(1) to stop the STP pump.
	<p>Pins for inputting the RESET signal. When a safety function operates, remove the cause of the abnormality/error after confirming the STP pump has stopped. When the cause of the abnormality/error is removed, supply 12 to 24 VDC to the circuits between (22)-(1) for 0.3 seconds or more to reset the failure signal (The "FAILURE" LED extinguishes).</p>

Table 20 - X2 REMOTE input signal pins (voltage input)

Pin	Description
<p>(1) (5)</p> <p>COM - + INHIBIT IN 12 to 24V DC</p>	<p>Pins for inputting the rotation INHIBIT signal. The input pins are valid even when input operation port is set to serial port. When the pins (5)-(1) are shutoff, the STP pump does not rotate despite the presence of a start signal. When these pins are shutoff while the pump is operating, the pump will stop (see Section 4.9.3) When using this function, supply 12 to 24 VDC to the circuits between (2)-(1) of the rotation INHIBIT enable signal.</p>
<p>(1) (4)</p> <p>COM - + PORT SELECT IN 12 to 24V DC</p>	<p>Pins for inputting the input operation port select signal. When 12 to 24 VDC is supplied to the pins between (4)-(1), the input operation port will be set to the parallel port automatically, and the input operation via the serial port is disabled. When voltage is not supplied to the pins between (4)-(1), a parallel port or any of three serial ports from COM1 to COM4 can be selected in the input operation port (see Section 5)</p>
<p>(1) (2)</p> <p>COM - + INHIBIT ENABLE IN 12 to 24V DC</p>	<p>Pins for inputting the rotation INHIBIT enable signal. The input pins are valid even when input operation port is set to serial port. When 12 to 24 VDC is supplied to the pins between (2)-(1), the rotation INHIBIT signal input is enabled.</p>
<p>(1) (23)</p> <p>COM - + OPT IN DC12~24V</p>	<p>Pins for option signal input. When 12 to 24 VDC is supplied to the pins between (23)-(1), from shutoff state, rotational speed in the normal state will be second speed. When the voltage between (23)-(1) are shutoff from 12 to 24 VDC supply state, the rotational speed in the normal state will be normal speed. When using this function, set the second speed option to the "ENABLE" from serial communication port or STP-Link. (see Section 5.4)</p>

Table 21 - X2 REMOTE input signal pins (voltage input) (continued)

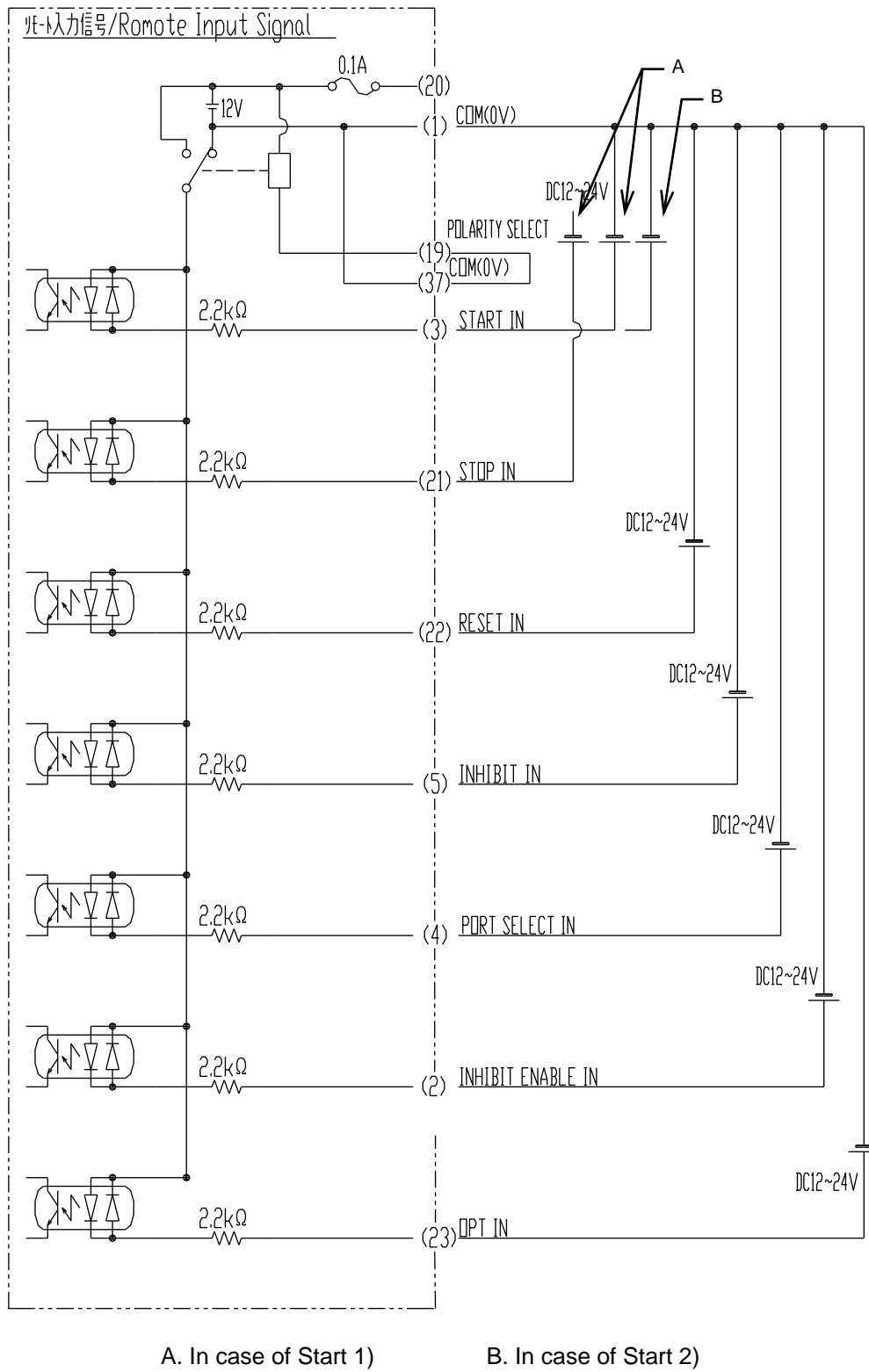

Figure 38 - X2 REMOTE input signal pins (voltage input)

4.9.2 Input operation port setting

Set the input operation port to the parallel port when operating the STP pump via the connector X2. The input operation port can be changed by "PORT SELECT IN" signal of the connector X2 and "Remote Operation Mode" setting. When "PORT SELECT IN" signal is closed, the input operation port will set to the parallel port automatically regardless of the Remote Operation Mode setting. When the "PORT SELECT IN" signal is opened, any input operation ports are selectable in the Remote Operation Mode (see Table 22).

The default setting of the Remote Operation Mode is "I/O Remote" (parallel port). It can be set via serial communication, the STP-Link (optional accessory).

"X2 REMOTE" PORT SELECT IN (4)-(1)	Input operation port	
	Remote Operation Mode setting is "I/O Remote"	Remote Operation Mode setting is COM1 to COM3
Close or Supply 12 to 24 VDC *1	Parallel port	Parallel port
Open or Shutoff 12 to 24 VDC *1	Parallel port	Serial port (COM1 to COM3)

*1 Apply 0 V to (1) pin.

Table 22 - Input operation port setting

4.9.3 Rotation INHIBIT signal

When using rotation INHIBIT signal, short-circuit the "INHIBIT ENABLE IN" signal. Relations between rotation INHIBIT signal input and pump operation state are shown in Table 23.

4

OPERATION

Signal input	Pump operation
<p>After short-circuit of rotation INHIBIT input signal (A), the START operation is performed (B).</p> 	<ul style="list-style-type: none"> The pump accelerates when the START operation is performed (B).
<p>After the START operation (A), the rotation INHIBIT input signal is short-circuited (B).</p> 	<ul style="list-style-type: none"> The pump does not accelerate when the START operation is performed (A). The pump accelerates when the rotation INHIBIT input signal is short-circuited (B).
<p>The rotation INHIBIT input signal is opened (A) during acceleration or normal operation.</p> 	<ul style="list-style-type: none"> The pump decelerates and stops when the rotation INHIBIT input signal is opened (A). After the operation (A), the pump continues deceleration and stops even by short-circuiting the rotation INHIBIT input signal (B). However, when the START signal is input, the pump will accelerate.

Table 23 - Rotation INHIBIT signal input

4.9.4 Second speed option

When the second speed option is enabled, second rating speed can be set independently of the normal rating speed setting. The selection of the second rating speed and normal rating speed are operated from I/O remote input or serial communication port.

The second speed setting is changed from serial communication port, or STP-Link. (see Section 5.4, "Command specifications")

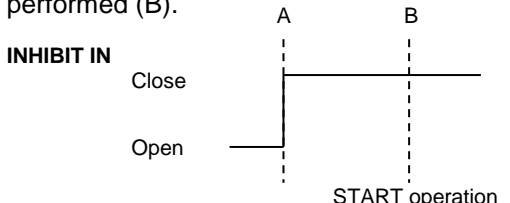
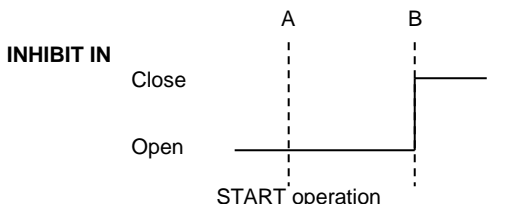
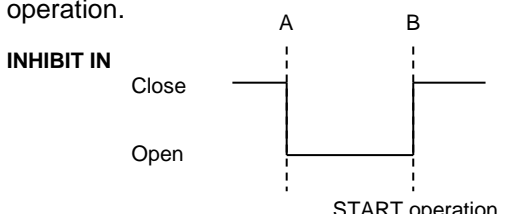
Table 24 shows pump status in the state of speed selection.

Pump status	
<p>Difference between Normal Speed and Second Speed Setting is more than approximately 10%</p>	<p>When the rotational speed becomes low, the STP pump enters BRAKE mode, and then decelerates. When the rotational speed becomes high, the STP pump enters ACCEL mode, and then accelerates. The STP pump will enter the normal mode when the rotational speed attains within +10% of speed setting.</p> <p>Rotational speed</p> <p>Speed Set Point</p> <p>Second Speed Set Point</p> <p>Speed Set Point +10%</p> <p>Speed Set Point -10%</p> <p>Second Speed Set Point +10%</p> <p>Second Speed Set Point -10%</p> <p>Pump status: NORMAL BRAKE NORMAL ACCEL NORMAL</p> <p>Second speed select: OFF ON OFF</p>
<p>Difference between Normal Speed and Second Speed Setting is approximately 10% or less</p>	<p>The rotational speed changes in the normal mode.</p> <p>Rotational speed</p> <p>Speed Set Point</p> <p>Second Speed Set Point</p> <p>Speed Set Point +10%</p> <p>Speed Set Point -10%</p> <p>Second Speed Set Point +10%</p> <p>Second Speed Set Point -10%</p> <p>Pump status: NORMAL</p> <p>Second speed select: OFF ON OFF</p>

Table 24 - Second speed function



STP-iXA3306 Series Turbomolecular Pump

4.9.5 Output signal pins

Table 25 and Figure 39. The pins function when the input operation port is either in parallel port setting or serial port setting.

Three abbreviations are used in Table 25.

N.O OUT:	Normal Open Output Pin
N.C OUT:	Normal Close Output Pin
COM:	Common Pin

Pin	Description
<p>(9) POWER N.O OUT (28)</p>	<p>Pins for outputting the POWER ON state signal. These pins are closed when magnetic bearing functions and the rotor levitates. This output is opened at a power failure</p>
<p>(10) ACCELERATION N.O OUT (29)</p> <p>NORMAL</p> <p>(11) N.O OUT (12) N.C OUT COM (30)</p>	<p>Pins for outputting the ACCELERATION state signal. These pins are closed when the STP pump is in acceleration.</p> <p>Pins for outputting the NORMAL OPERATION state signal. When the STP pump is in rated operation, the pins between (11)-(30) are closed, and the pins between (12)-(30) are opened.</p>
<p>(13) BRAKE N.O OUT (32)</p> <p>FAILURE</p> <p>(14) N.O OUT (15) N.C OUT COM (33)</p> <p>WARNING</p> <p>(24) N.O OUT (25) N.C OUT COM (6)</p>	<p>Pins for outputting the BRAKE state signal. These pins are closed when the STP pump is in brake.</p> <p>Pins for outputting the FAILURE signal. When an abnormality/error is detected, the pins between (14)-(33) are closed, and the pins between (15)-(33) are opened.</p> <p>Pins for outputting the WARNING signal. These pins are closed when the STP pump is WARNING state. Refer to Section 7.2, "Safety Functions" for the warning.</p>
<p>(34) I/O ENABLE N.O OUT (31)</p> <p>AT TEMP</p> <p>(16) N.O OUT (35) N.C OUT COM (17)</p>	<p>Pins for outputting the parallel port select state signal. When the input operation port is set to the parallel port (I/O REMOTE), the pins are closed.</p> <p>Pins for the TMS unit rated state signal output. When the actual temperature of the TMS unit is within the setting temperature range $\pm 10^{\circ}\text{C}$, the pins between (16)-(17) are closed and the pins between (35)-(17) are opened.</p>

Table 25 - X2 REMOTE output signal pins

Pin	Description
(7) OPT N.O OUT (26)	Pins for optional signal output. In state of the second speed option is "ENABLE", and second speed is selected, the pins between (7)-(26) are closed and the pins between (7)-(26) are opened.

Table 26 - X2 REMOTE output signal pins (continued)

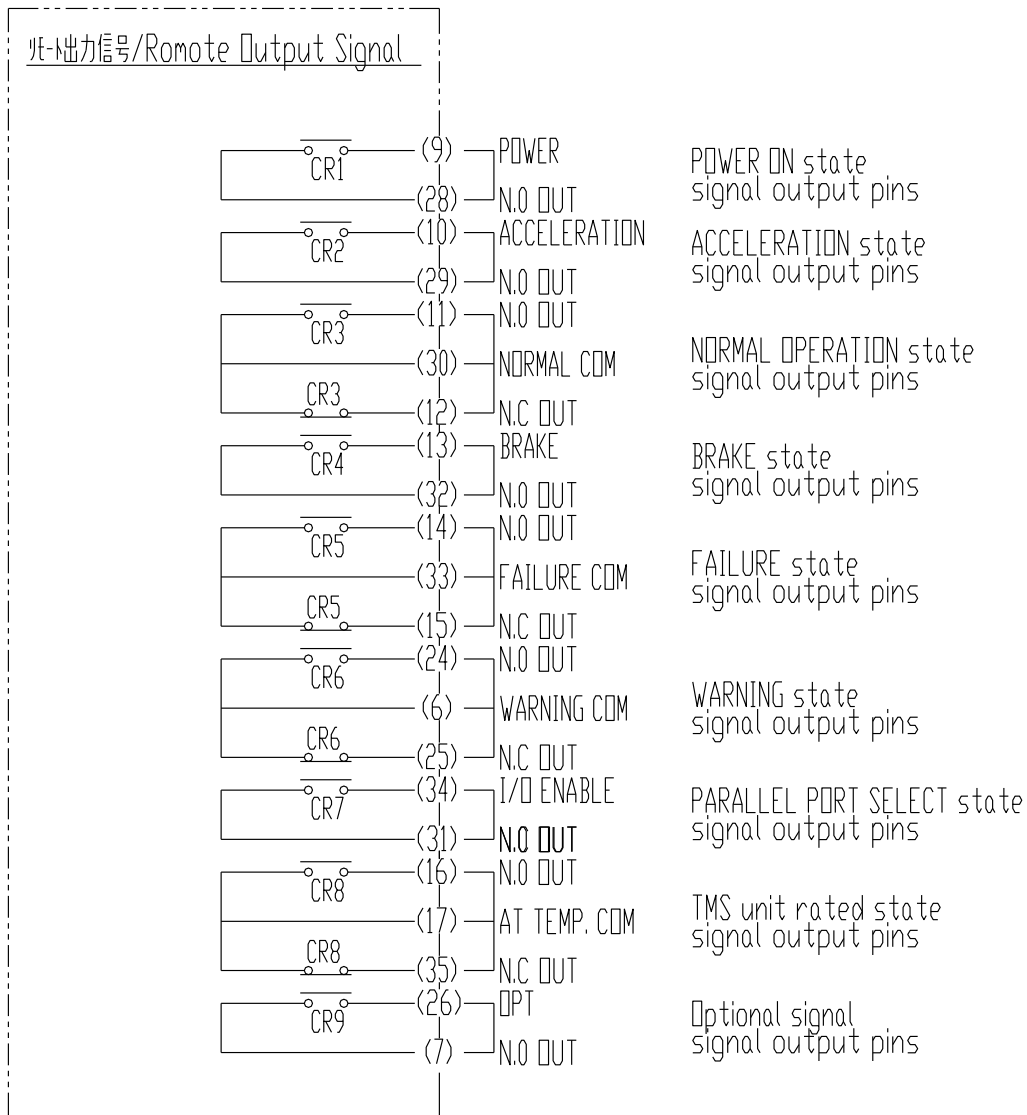

Figure 39 - X2 REMOTE output signal pins



STP-iXA3306 Series Turbomolecular Pump

Table 27 shows the rated contacts for relays CR1 to CR8 in Figure 39.

	Resistance Load (COS Ø=1)
Rated Load	30 V DC, 0.5 A
Rated Current	0.5 A
Maximum Contact Point Current	0.5 A
Maximum Open/Close Capacity	DC: 15 W
Minimum Applicable Load	10 mV DC, 10 µA

Table 27 - Rated contacts for relays CR1 to CR8

4.10 Operating the TMS unit (for use with the TMS unit)

4.10.1 Before starting

Check the following items before starting:

1. Check that the TMS heater cable is securely connected to the "X12 HEATER" connector on the control unit.
2. Check that the TMS valve and the cooling water pipe are securely connected.

4.10.2 Starting/Stopping

Power on the STP pump to automatically start the TMS unit.

Power off the STP pump to automatically stop the TMS unit.

When STP pump is in the power ON state, the TMS unit operates regardless of the status of the STP pump. When the STP pump is the cause of the malfunction, the TMS unit is stopped.

4.10.3 Setting the TMS unit function

When the temperature of the STP pump base is lower than the setting value, the TMS heater is turned "ON", and the TMS valve is turned "OFF" to heat the STP pump. When the temperature of the STP pump base is higher than the setting value, the TMS heater is turned "OFF", and the TMS valve is turned "ON" to cool the STP pump.

5 SERIAL COMMUNICATION PROTOCOL

5.1 Introduction

STPiXA3306 series is provided with compliant serial RS232/RS485 interface. Prepare the user application according to this protocol procedure. Operation instructions and information, such as the running state and setting values of the STP pump can be set by the software.

The STP pump equips the serial ports for connecting the user application, STP-Link (optional accessory), or the display unit iDT-001 (optional accessory). (see Figure 40)

The STP pump is equipped with 3 serial ports COM1, COM2 and STP-Link as a standard.

A serial port located the STP pump is called a serial interface module (hereafter referred to as SIM). The equipment, which can communicate with the STP pump via RS232/RS485, is called a PC.

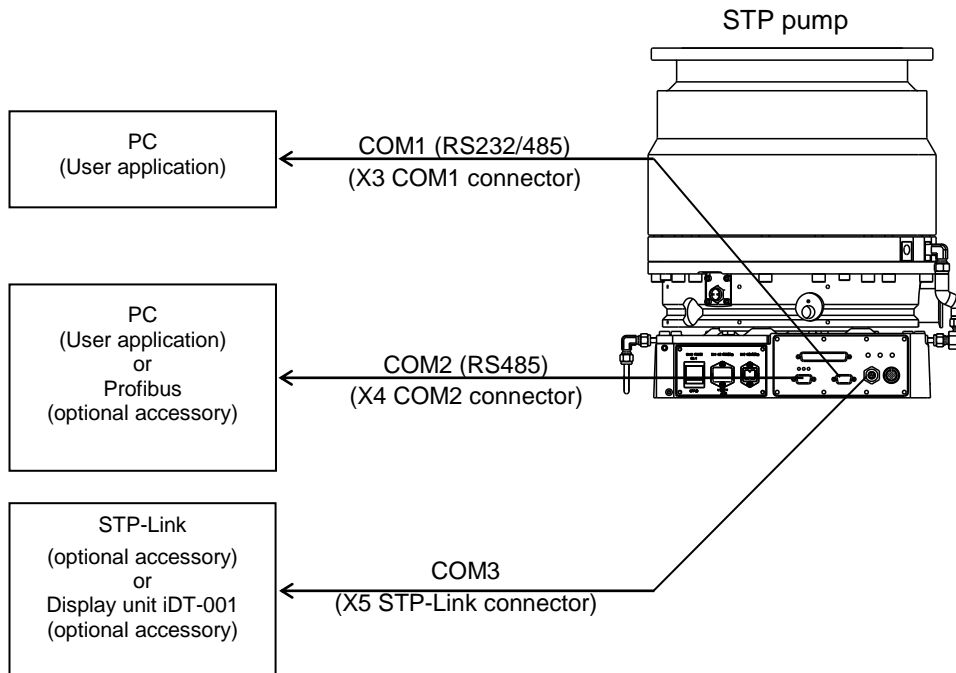

Figure 40 - Serial port

5.2 Connection and setting up

5.2.1 Signal connection

1. Serial Port COM1 (X3 COM1 connector)

The serial port COM1 is available for the serial communication via RS232 or RS485. When using a user application, connect it to this port.

Connect the connector X3 (D-Sub9 pin, socket type) to the PC according to Table 28. Connect only TxD/RxD/GND in the RS232 and D+/D- in the RS485. DO NOT connect other pins which are reserved as optional use. DO NOT use a commercially available straight cable which all lines are connected.

2. Serial Port COM2 (X4 COM2 connector)

The serial port COM2 is available for the serial communication via RS485. When using a user application, connect it to this port.

Connect the connector X4 (D-Sub9 pin, socket type) to the PC according to Table 28. DO NOT connect other pins which are reserved as optional use.

However, when using the Profibus (optional accessory), serial communication function is not available because of the different connector pin position. (see the Instruction Manual of the Profibus)

	X3 (D-Sub9 pin, socket)	X4 (D-Sub9 pin, socket)
RS232	2 (TxD)	-
	3 (RxD)	-
	5 (GND)	-
RS485	7 (D-)	7 (D-)
	8 (D+)	8 (D+)
Reserved	1, 4, 6*, 9	1, 2, 3, 4, 5, 6, 9

* The pin 6 of the connector X3A outputs 7 VDC for option units. DO NOT connect the pin 6. Doing so may result in damage to peripheral equipments damage, such as PC.

Table 28 - X3/X4 pin position

STP-iXA3306 Series Turbomolecular Pump

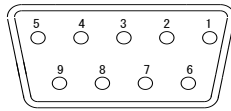

Figure 41 - X3/X4 connector (D-Sub9)

Note: The connectors X3 and X4 are fitted using M2.6 screws.

The RS232 and RS485 share the X3 COM1 port.

When connecting RS232, the length of the communication cable should be 15 m or less. When connecting RS485, refer to Section 5.2.2.

3. Serial Port COM3 (X5 STP-Link connector)

The STP-Link (optional accessory) or the display unit iDT-001 (optional accessory) can be connected to the serial port COM3.

5.2.2 Connecting the RS485

Make sure the followings when using the serial port COM1 with RS485 or COM2.

- A connection condition is 1 on 1 (single point connection) or 1 on N (multi-point connection). A maximum number of 32 SIMs are connectable in the multi-point connection.
- After receiving commands, SIM will return a response approximately 5 msec later at the shortest. Connect the PC of which transmit/receive switch time is 5 msec or less.
- Use twisted-pair wire in communication cable. The extended communication cables should be 1.2 km or less.
- Connect the terminator to the communication devices at both ends of the transmission line. The terminator (120 Ω, 0.25 W) is required for connection. (STP-iXA3306 series does not have terminator setting function)

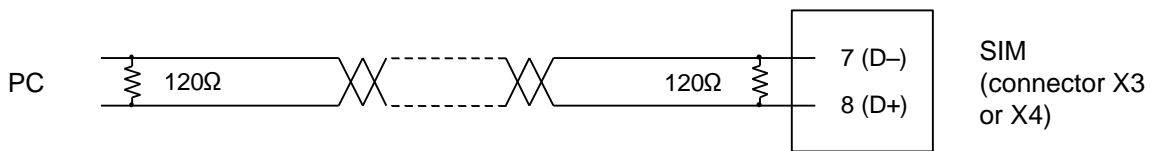

a) RS485 single point connection

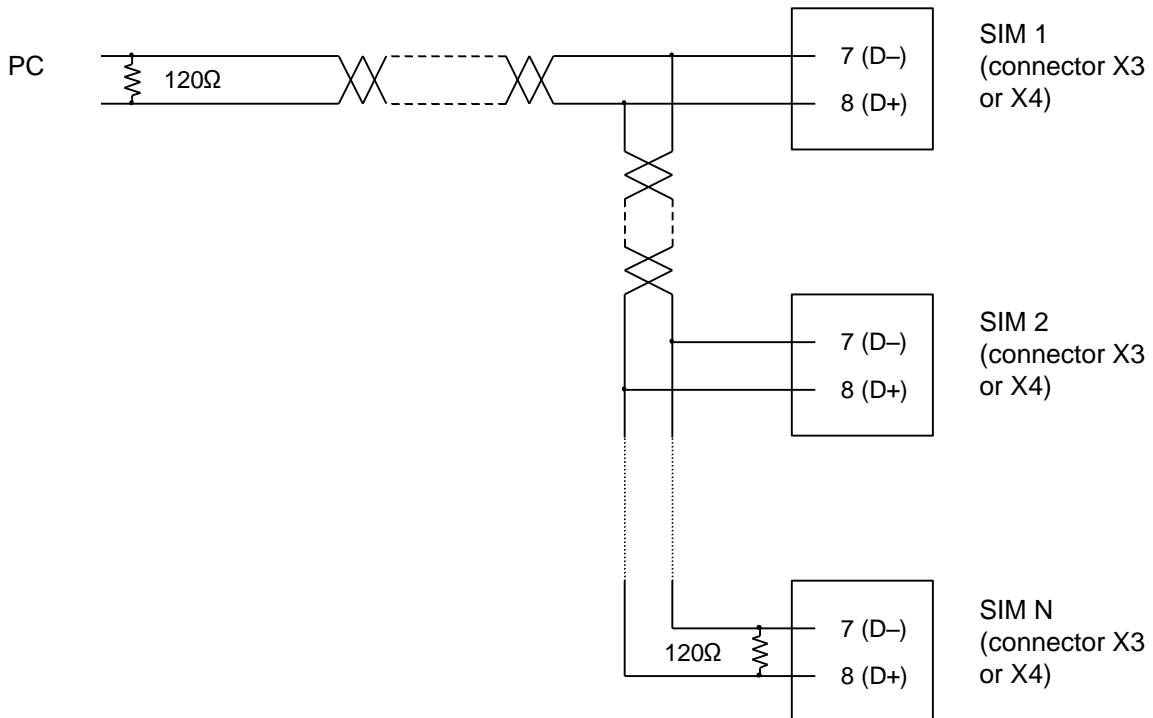

b) RS485 multi-point connection

Figure 42 - RS485 connections



STP-iXA3306 Series Turbomolecular Pump

5.2.3 Communication parameter setting

The factory setting of COM1 and COM2 is shown in Table 29. To set communication parameters, use the STP-Link (optional accessory) or the display unit iDT-001 (optional accessory).

Communication parameter		Factory setting	PC setting example
Baud rate		9,600 bps	1,200 to 56,000 bps
Bit length		8 bit	7, 8bit
Stop bit		1 bit	1, 2bit
Parity		None	None, Even, Odd
Driver type	COM1	RS232/RS485 single	RS232/RS485 single, RS485 multi
	COM2	RS485 single	RS485 single, RS485 multi
RS485ID *1		1	1 to 127

*1 It is used in RS485 Multi.

Table 29 - Communication parameters

5.2.4 Input operation port setting

Set the input operation port to the serial port when operating the STP pump via the serial port in accordance with the following procedures.

1. Open the "PORT SELECT IN" signal between (1)-(4) of the "X2 REMOTE" connector.
If the pins are closed, the input operation port will be set to the parallel port automatically, and the input operation via the serial port is disabled (refer to Section 4.9, "Parallel port input/output signal" for the details of the "X2 REMOTE" connector).
2. Set the parameter of the "Input operation port" to the serial port which operates STP pump, following Section 5.4.16. The parameter value of the factory setting is "I/O REMOTE" (parallel port). The "Input Operation Port" can also be changed via the STP-Link (optional accessory).

	Input operation port	Remark
Parallel port	I/O Remote	X2 REMOTE connector
Serial port	COM1	X3 COM1 connector
	COM2	X4 COM2 connector, Profibus (optional accessory)
	COM3	X5 STP-Link connector

Table 30 - Input operation port

Note: Any commands other than STP pump operation are effective in every port regardless of the input operation port setting.

5.2.5 Serial communication timeout setting

If the signal to the input operation port of the STP pump is interrupted for a certain period during acceleration or normal operation, the STP pump detects a failure and stops. The time setting of the failure detection is user definable. When setting the value to 0, the function is disabled. This value will be common to all serial ports, and the factory setting is 1 minute.

The setting value can be changed via serial communication, the STP-Link (optional accessory). (see 5.4.17)

Design the user application so that the PC can communicate with the STP pump at fixed regular intervals within the setting time, except when the function is disabled (the value is 0).

	Default	Setting Range	Remark
Serial communication time out setting	1 minute	0 to 500 minutes (1 minute step)	The function is disabled when the value is set to 0.

Table 31 - Serial communication time out setting

Note: When the communication time out is disabled, the STP pump may not stop when the serial communication does not function normally due to a breakage of the communication cable. In this case, interrupt the power supply for 2 seconds or more to stop the STP pump by power failure detection. Supply the power to the STP pump immediately after power failure detection.

5.2.6 Recommended items about communication cable installation

Noise generated by many factors such as the type or length of cable, communication speed, and different communication devices may cause the communication failure with a serial port. It is very difficult to prevent a communication failure completely. The followings are valid methods to countermeasure against a noise for the communication cable.

- Use a shield type product for communication cable, and an EMI countermeasure product for the communication connector hood. Choose the suitable grounding method according to the operating environment.

[Both ends grounding (Electromagnetic shielding)]

The grounding method for reducing the inducted voltage produced in the communication line by the magnetic field emitted from a power supply line. Shield both ends are grounded by all the cables of connected communication device. Clamp the STP pump side shield on a connector hood. A ground loop will be made up through both ends grounding. Connect between GND of a STP pump and PC with low impedance to prevent ground potential difference.

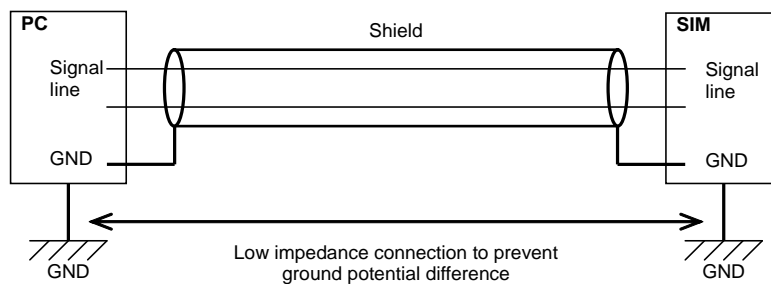

Figure 43 - Grounding example (Both ends grounding)

[Single point grounding (Electrostatic shield)]

This is the grounding method for reducing the electrostatic induction produced in the communication line by the exogenous noise caused by electrostatic induction or unnecessary radiation. Ground the communication cable shield by single point to the PC side. DO NOT ground on STP pump side. When ground potential difference is high, the single point grounding may be more effective than both ends grounding against a noise.

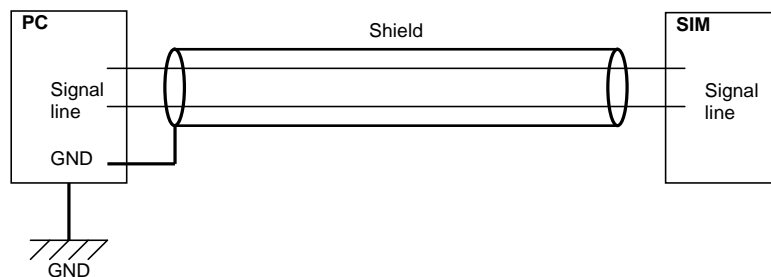

Figure 44 - Grounding example (single point grounding)

STP-iXA3306 Series Turbomolecular Pump

- DO NOT bundle a communication line with a protective earth conductor or a power line. Moreover, keep away a communication line from the apparatus used as a noise source as much as possible.
- As radio frequency noise measure, place a ferrite core on both ends of the communication cable. When electromagnetic interference caused by radio frequency noise in frequency band (150 kHz to 1 GHz) affects communication, attaching ring ferrite cores to the cable is effective to reduce communication failure.

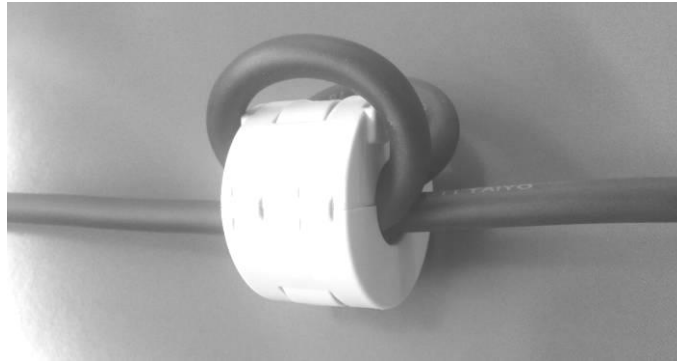

Figure 45 - Example of ring ferrite core installation

- Locate and secure the cables.
It may be difficult to measure the reproducibility of the communication failure without securing the cables.
- Avoid installing a power line and a communication line in the same metallic duct.
When unavoidable, separate a line with a metal separator certainly, and connect the duct containing a metal separator certainly to GND, or installing a communication line put into conductive pipes, such as metal.

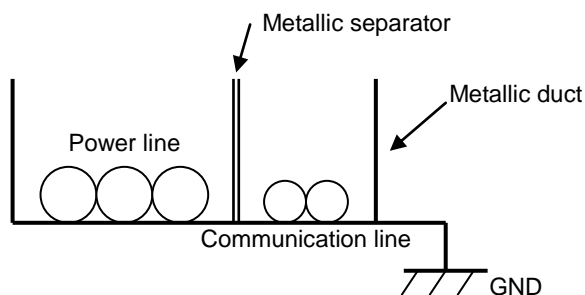

Figure 46 - Example of cable installation in metallic duct

STP-iXA3306 Series Turbomolecular Pump

- DO NOT insert or remove a communication cable while a communication device and a STP pump are turned ON the power.
Communication interface circuit may break down if surge voltage caused by such as potential difference of communication interfaces or static electricity is applied to communication line.

Communication failure occurs frequently by broken communication interface circuit. RS485 is available with communication interface circuit according to the environment, but it gets failure easily. Check the waveform of the differential signal is normal with measuring instruments, such as an oscilloscope.

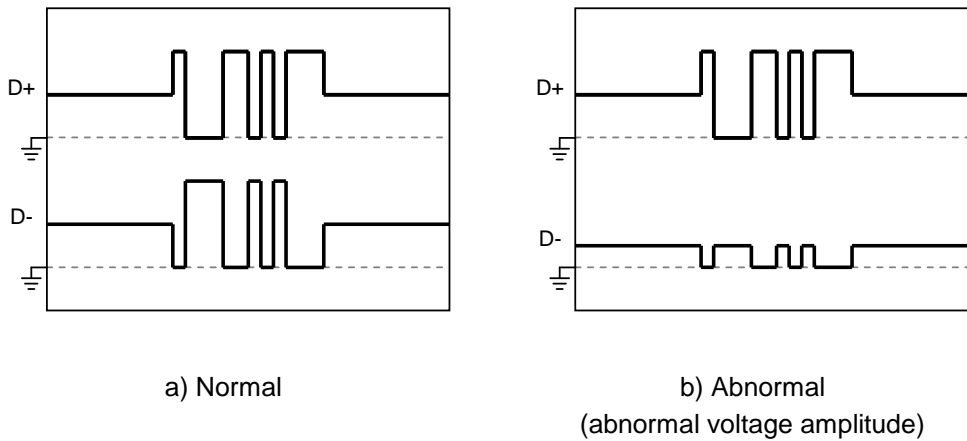

Figure 47 - Example of differential signal waveform

5.3 Protocol specifications

5.3.1 General description

The STP serial communication protocol enables the SIM to receive the communication command transmitted from the PC and sends a response following the communication command (Figure 48-1). Each communication command from the PC transmits a text message (ASCII text) assigned to each function (Figure 48-2). Communication commands include control commands (STP pump operation commands, etc.) and query commands (read-out of STP pump operation mode, etc.).

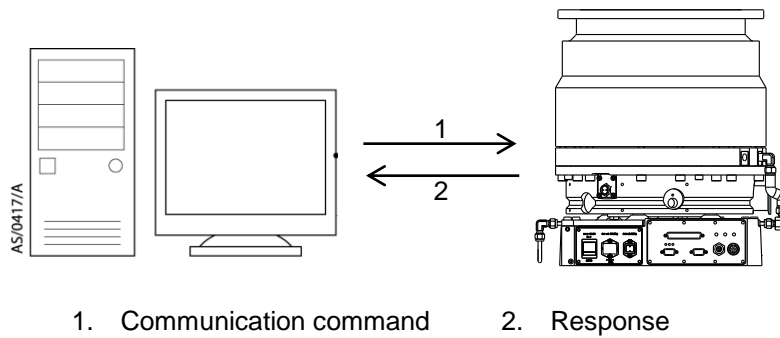

Figure 48 - PC to SIM communication

Table 32 shows ASCII characters being used in the transmission control, error control and handshake in the application layer.

	ASCII character	HEX code	Function
Transmission layer	Stx	02	Transmission block start character
	Etx	03	Transmission frame end character
	Etb	17	Transmission block end character
	Ack	06	Acknowledgment response
	Nak	15	Non-acknowledgment response
	@	40	Network frame ID character
Application layer	#	23	Acknowledgment response
	!	21	Non-acknowledgment response

Table 32 - Transmission control characters

5.3.2 Standard transmission frame

The transmission frame has a single block or multiple transmission blocks. The transmission block consists of a start control character, data block No. (3 digits), a message (up to 255 characters), an end control character, and a checksum (LRC). The following table shows the transmission frame where the message transmission character string is C_n .

Transmission frame when a message is below 255 characters ($n \leq 255$):

	1	2	3	4	5		5+n	5+n+1	5+n+2
ASCII	Stx	0	0	1	C_1		C_n	Etx	LRC

"Stx" and "Etx" are used as a start and an end character of the transmission frame, respectively.

STP-iXA3306 Series Turbomolecular Pump

Transmission frame when a message exceeds 255 characters (n = 255, m <= 255, k = the number of transmission blocks):

First		1	2	3	4	5		5+n	5+n+1	5+n+2
Block	ASCII	Stx	0	0	1	C1 ₁		C1 _n	Et _b	LRC
Second		1	2	3	4	5		5+n	5+n+1	5+n+2
Block	ASCII	Stx	0	0	2	C2 ₁		C2 _n	Et _b	LRC
Final		1	2	3	4	5		5+m	5+m+1	5+m+2
Block	ASCII	Stx	k			Ck ₁		Ck _m	Et _x	LRC

"Stx" is used as a start character of each transmission block; "Et_b" is used as an end character of the transmission block with a message of 255 characters; "Et_x" is used as an end character of the final transmission block (the end character of the transmission frame).

5.3.3 Control command (in the RS232/RS485 single point connection)

A control command is used when transmitting a pump operation commands and a setting change commands to the SIM. The first character of the control command is "Sp" (a space character, HEX code "20"), and succeeding characters are ASCII characters corresponding to the respective function code and parameter.

Sp	CHR	C ₁	C ₂				C _n
----	-----	----------------	----------------	--	--	--	----------------

CHR: Function code character, C₁ to C_n: Parameter.

Parameter (from C₁ to C_n) serves as 16 bits signed hexadecimal value coded ASCII text. When a message (a space character, a function code, and parameter) exceeds 255 characters, input "Sp" and CHR to the top transmission block only (the first transmission block of the transmission frame). It is not necessary to input them to the second and succeeding transmission blocks.

The SIM returns the acknowledgment response character "#" when the control command is processed normally. If not, the SIM returns the non-acknowledgment response character "!" and 3 characters of the non-acknowledgment code are added to "!".

Transmission frame when data is transmitted to one block (a message is less than 256 characters):

Designate the control command on the PC.

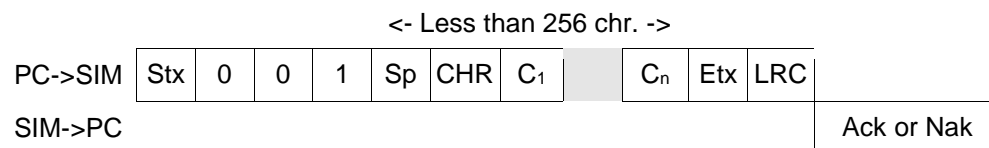

Always assign less than 254 characters (n < 254) to the parameter so that the message is less than 256 characters.

STP-iXA3306 Series Turbomolecular Pump

Then the preceding SIM->PC character is "Ack", the instructed control command is executed and the SIM returns the following response.

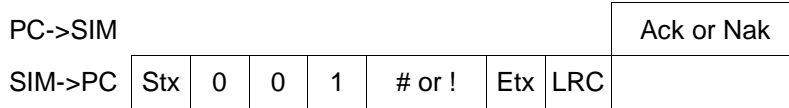

The PC transmits "Ack" or "Nak"; then transmits the next command if necessary.

Transmission frame when data is transmitted to two blocks (message is more than 256 characters and less than 512 characters):

Designate the control command (the 1st block) on the PC

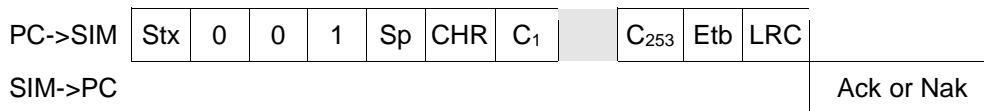

Next, the preceding SIM->PC character is "Ack", the PC continues instructing the control command (the 2nd block).

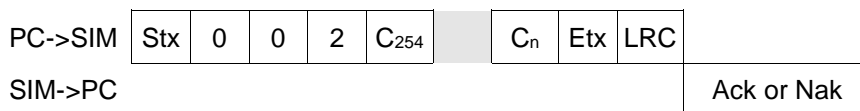

Always assign less than 510 characters (n < 510) to the parameter so that the message is less than 512 characters.

Then the preceding SIM->PC character is "Ack", the instructed control command is executed and the SIM returns the following response.

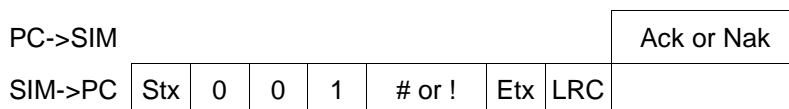

The PC transmits "Ack" or "Nak"; then transmits the next command if necessary.

5.3.4 Query command (in the RS232/RS485 single point connection)

A query command is used to read the pump operation state and setting values. The first character of the query command in the RS232/RS485 single point connection is "?" (HEX code "3F"), and succeeding characters are ASCII characters corresponding to the respective function code and parameter.

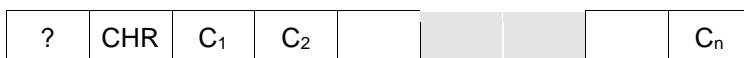

CHR: Function code character, C₁ to C_n: Parameter

STP-iXA3306 Series Turbomolecular Pump

Parameter (from C₁ to C_n) serves as 16 bits signed hexadecimal value coded ASCII text. When a message (a space character, a function code, and parameter) exceeds 255 characters, input "?" and CHR to the top transmission block only (the first transmission block of the transmission frame). It is not necessary to input them to the 2nd and succeeding transmission blocks.

The SIM returns the acknowledgment response character "#" when the query command is processed normally. If not, the SIM returns the non-acknowledgment response character "!" and 3 characters of the non-acknowledgment code are added to "!".

Transmission frame when data is transmitted at one block and returned at two blocks:

Designate a query command on the PC

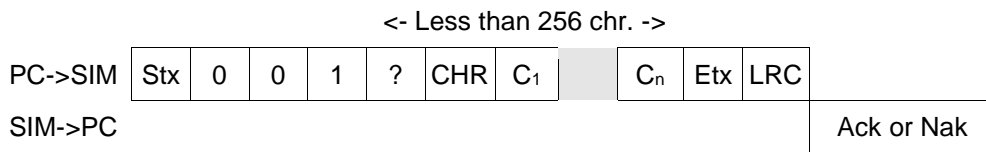

Always assign less than 254 characters (n < 254) to the parameter so that the message is less than 256 characters.

Next, the preceding SIM->PC character is "Ack", the instructed query command is executed and the SIM returns the following response (1st block).

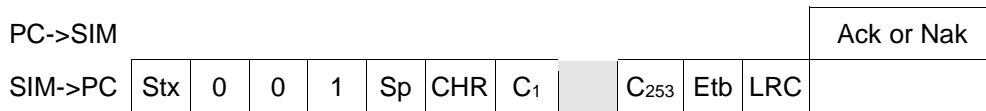

Then "Ack" is sent by the PC->SIM character in reaction to the response (1st block) from the SIM, the SIM returns the following response (2nd block).

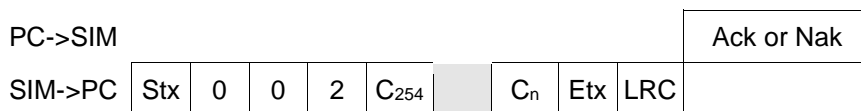

The PC transmits "Ack" or "Nak"; then transmits the next command if necessary.

5.3.5 Transmission data format

Data value is always 16 bits signed hexadecimal value coded ASCII text.

Example: 12090 on a decimal basis equals to 2F3A on a hexadecimal basis.

5.3.6 Frame control (checksum)

The transmission frame is controlled by the odd number parity check. First initialize LRC as FF_{hex}. Next calculate LRC by EXCLUSIVE-OR (XOR) of all the frame bytes containing "Stx", "Etb", "Etx" and LRC and transmit the result as LRC.

Examples:

Character string for calculation before calculating LRC.

ASCII	Stx	0	0	1	#	Etx	LRC
HEX	02	30	30	31	23	03	FF

Calculation of LRC:

$$02_{\text{hex}} \text{ XOR } 30_{\text{hex}} \text{ XOR } 30_{\text{hex}} \text{ XOR } 31_{\text{hex}} \text{ XOR } 23_{\text{hex}} \text{ XOR } 03_{\text{hex}} \text{ XOR } FF_{\text{hex}} = EC_{\text{hex}}$$

Character string for transmission after calculating LRC.

ASCII	Stx	0	0	1	#	Etx	LRC
HEX	02	30	30	31	23	03	EC

However, when the MSB (most significant bit) is always 0 when data length is 7 bits, LRC is set to 6C_{hex}.

5.3.7 Error control

- Transmit the transmission frame repeatedly from the PC when the SIM transmits "Nak" (parity check error). When the SIM receives "Nak" from the PC, the transmission frame is transmitted again. This operation is repeated up to 5 times.
- The SIM transmits "Ack" or "Nak" to the PC after the completion of communication command reception. When the PC cannot receive "Ack" or "Nak" after 2 second, retransmit the transmission frame from the PC.

When these communication status occur repeatedly, display to an error message or start the error routine on the PC.

5.3.8 Transmission frame in the RS485 multi-point connection

To identify a network frame and ensure the compatibility with a standard transmission frame, add a network frame ID character "@" and a title of 3 characters of network frame number to the transmission frame in the RS485 multi-point connection.

The network frame number is specified by any 16 bits signed hexadecimal value coded ASCII text of 1 to 127, to identify the SIM.

STP-iXA3306 Series Turbomolecular Pump

Examples: Network frame ID character and number in the multi-point connection

ASCII	@	0	1	Network frame No "1"
HEX	40	30	31	
ASCII	@	6	4	Network frame No "100"
HEX	40	36	34	
ASCII	@	7	F	Network frame No "127"
HEX	40	37	46	

The transmission frame has a single block or multiple transmission blocks. Each transmission block consists of a network frame ID character, a network frame number, a start control character, data block number (3 digits), a message (up to 255 characters), an end control character and a checksum (LRC). The following shows the transmission frame when the message transmission character string is C_n .

Transmission frame when a message is below 255 characters ($n \leq 255$):

	1	2	3	4	5	6	7	8		8+n	8+n+1	8+n+2
ASCII	@	F ₁	F ₂	Stx	0	0	1	C ₁		C _n	Etx	LRC

"@" is used as a network frame ID character.

"Stx" and "Etx" are used as a start and an end character of the transmission frame, respectively.

Transmission frame when a message exceeds 255 characters ($n = 255$, $m \leq 255$, $k =$ the number of transmission blocks)

First Block		1	2	3	4	5	6	7	8		8+n	8+n+1	8+n+2
	ASCII	@	F ₁	F ₂	Stx	0	0	1	C _{1₁}		C _{1_n}	Etb	LRC
Second Block		1	2	3	4	5	6	7	8		8+n	8+n+1	8+n+2
	ASCII	@	F ₁	F ₂	Stx	0	0	2	C _{2₁}		C _{2_n}	Etb	LRC
Final Block		1	2	3	4	5	6	7	8		8+m	8+m+1	8+m+2
	ASCII	@	F ₁	F ₂	Stx	k			C _{k₁}		C _{k_m}	Etx	LRC

"@" is used as a network frame ID character.

"Stx" is a start character of each transmission block, and "Etb" is an end character of the transmission block of a message of 255 characters.

"Etx" is used as an end character of the final transmission block (end character of the transmission frame).

5.3.9 Control command in the RS485 multi-point connection

The control command to be used when a pump operation instruction or a setting change instruction is transmitted to the SIM and is arranged in the order specified below. The top is "Sp" (space character, HEX code "20") and ASCII characters corresponding to the respective function code and parameter follow.



CHR: Function code character, C₁ to C_n: Parameter

Parameter (from C₁ to C_n) serves as 16 bits signed hexadecimal value coded ASCII text. When a message (a space character, a function code, and parameter) exceeds 255 characters, input "Sp" and CHR to the top transmission block only (the first transmission block of the transmission frame). It is not necessary to input them to the second and succeeding transmission blocks.

The SIM returns the acknowledgment response character "#" when the control command is processed normally. If not, the SIM returns the non-acknowledgment response character "!" and 3 characters of the non-acknowledgment code are added to "!".

Transmission frame when data is transmitted to one block (a message is less than 256 characters):

Designate the control command on the PC.

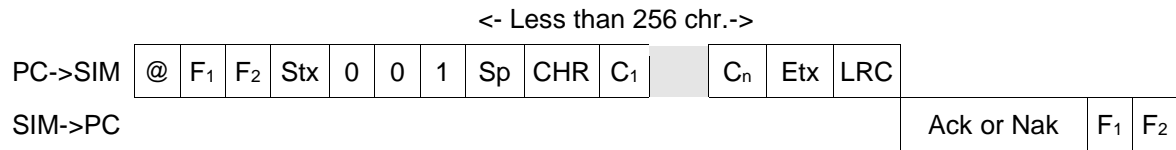

Always assign less than 254 characters (n < 254) to the parameter so that the message is less than 256 characters.

Next, the preceding SIM->PC character is "Ack", the instructed control command is executed and the SIM returns the following response.

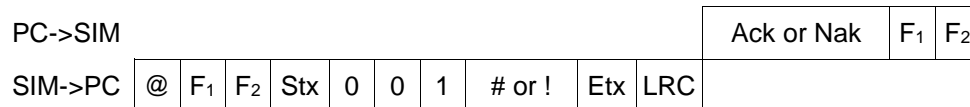

The PC transmits "Ack" or "Nak"; then transmits the next command if necessary.

Transmission frame when data is transmitted to two blocks (message is more than 256 characters and less than 512 characters):

Designate the control command (the 1st block) on the PC.

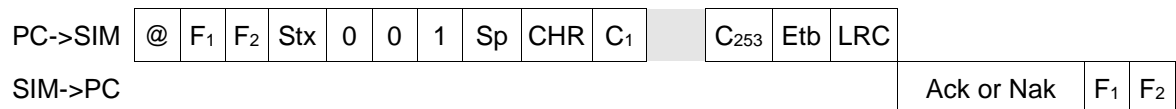

STP-iXA3306 Series Turbomolecular Pump

Next, the preceding SIM->PC character is "Ack", the PC continues instructing the control command (the 2nd block).

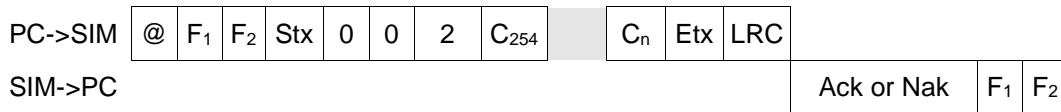

Always assign less than 510 characters (n < 510) to the parameter so that the message is less than 512 characters.

Then the preceding SIM->PC character is "Ack", the instructed control command is executed and the SIM returns the following response.

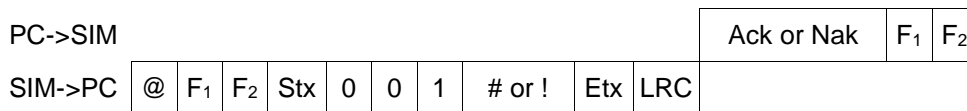

The PC transmits "Ack" or "Nak"; then transmits the next command if necessary.

5.3.10 Query command in the RS485 multi-point connection

The query command to be used when a pump operation instruction or a setting change instruction is transmitted from the SIM and is arranged in the order specified below. The top is "?" (HEX code "3F") and ASCII characters corresponding to the respective function code and parameter follow.



CHR: Function code character, C₁ to C_n: Parameter.

Parameter (from C₁ to C_n) serves as 16 bits signed hexadecimal value coded ASCII text. When a message (a space character, a function code, and parameter) exceeds 255 characters, input "?" and CHR to the top transmission block only (the first transmission block of the transmission frame). It is not necessary to input them to the second and succeeding transmission blocks.

The SIM returns the acknowledgment response character "#" when the query command is processed normally. If not, the SIM returns the non-acknowledgment response character "!" and 3 characters of the non-acknowledgment code are added to "!".

Transmission frame when data is transmitted from one block and returned to two blocks.

Designate a query command on the PC.

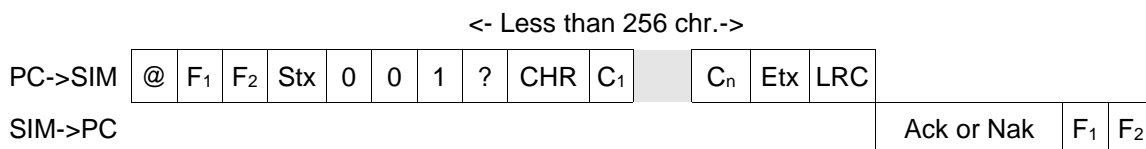

STP-iXA3306 Series Turbomolecular Pump

Always assign less than 254 characters ($n < 254$) to the parameter so that the message is less than 256 characters.

Next, the preceding SIM->PC character is "Ack", the instructed query command is executed and the SIM returns the following response (1st block).

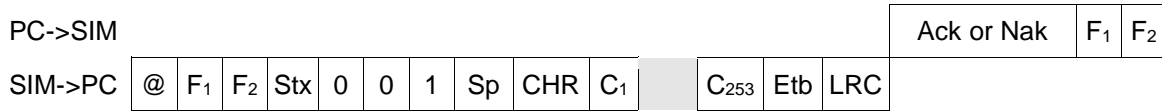

Then "Ack" is sent by the PC->SIM character in reaction to the response (1st block) from the SIM, the SIM returns the following response (2nd block).

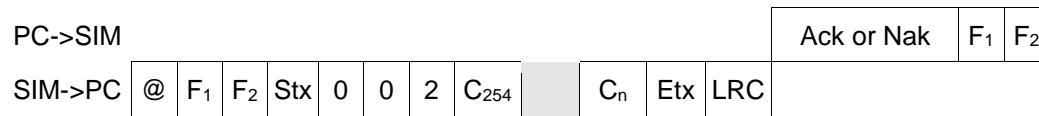

The PC transmits "Ack" or "Nak"; then transmits the next command if necessary.

5.3.11 Broadcasting command in the RS485 multi-point connection

The START or STOP of STP pump operation command can be concurrently instructed to all the multi-connected SIMs. Always assign 0 (HEX code "30", "30") to network frame number. Note that there is no response from the respective SIM.

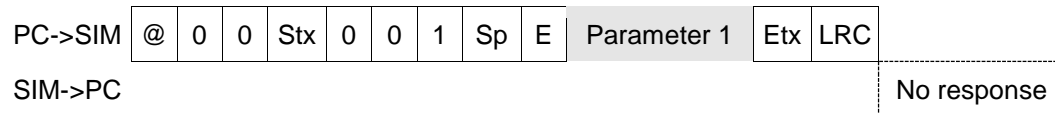

Parameter	Item	Data Format	Remark
1	Pump operation command	8-bits hexadecimal coded ASCII	Refer to Table 33

Pump operation command	Value
START	1
STOP	2

Table 33 - Pump operation commands

5.3.12 Application note

Noise generated by many factors such as the type or length of cable, communication speed, and different communication devices may cause the communication failure with a serial port. It is very difficult to prevent a communication failure completely. The followings are the methods to create the tool application with redundancy to a noise etc.

- Be sure to communicate according to the protocol. If it communicates by a different method from the procedure described by this manual, communication failure might cause.

Figure 49 shows the block diagram of the valid communication process from command sending to answer data receiving.

Moreover, the example of a communication procedure is shown in Figure 53, Figure 54, and Figure 55.

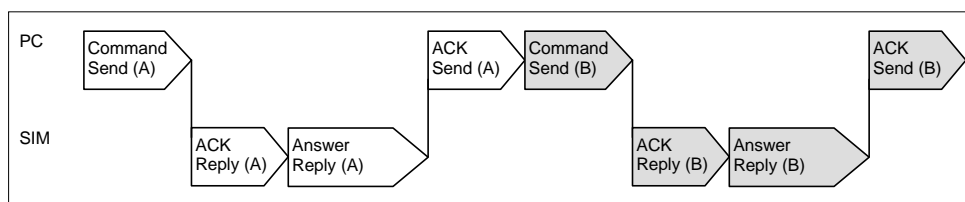

Figure 49 - Block diagram of communication process example

- The SIM will reply "ACK" or "NAK" within approximately 2 seconds after receiving command. When there is no reply, the SIM may not have received the command. In this case, resend the command from the tool application before recognizing the process of the communication failure. If the problem cannot solve after resending several times, make the process of the communication failure on tool application.
- A finishing of data received process should monitor with received character "Etx". Receiving process is completed by receiving the "LRC" (checksum) data after getting "Etx". This process can reduce the task of modifying the tool application when commands with different answer data size according to the pump model are received.

However, when the completion of the answer receiving process is determined by the number of received characters, check that "Etx" has been received and LRC checksum is correct.

- After sending the command, release the elapsed time process due to communication timeout each time when receiving answer data. When a large number of answer data is received, the answer receiving process of the tool application is timed out, and all data may not be able to obtain.

STP-iXA3306 Series Turbomolecular Pump

- Always check the LRC checksum of answer data. When LRC checksum is incorrect, do not use the data. When the incorrect data caused by noise is accepted, parameters might be set unexpected values. In this case, the processing of the tool application may determine to be a communication failure. When LRC checksum is incorrect, receive the answer data again according to the following methods.

- Send "NAK" within 1500 msec after receiving the answer data, and then receive the answer data again from SIM. However, when using RS485, send "NAK" at least 1 msec has passed after receiving the answer data.
- Stop once the communication process, and try the communication process again.

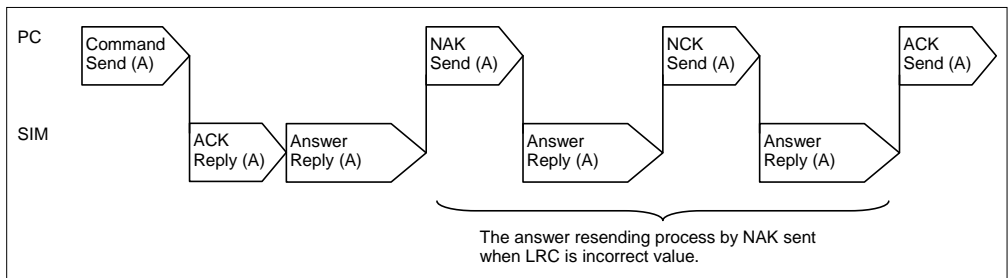

Figure 50 - Example of answer resending process

- When sending the following command before receiving the answer data from the SIM, the contents of the answer data and sent command from the SIM will not match. In this case, stop the communication about approximately 5 seconds to clear all the receiving buffer of the tool application, and then start the communication again.

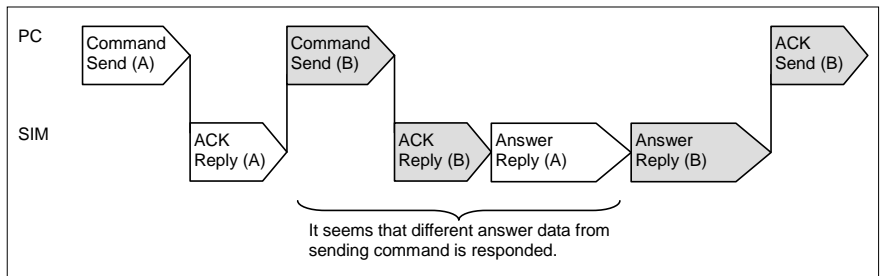

Figure 51 - Example of response when the command is sent continuously

In addition, when using RS485, do not send commands while the answer data is sent from the SIM. The crosstalk of sending data and receiving data will occur, and it causes communication failure such as a flaming error.

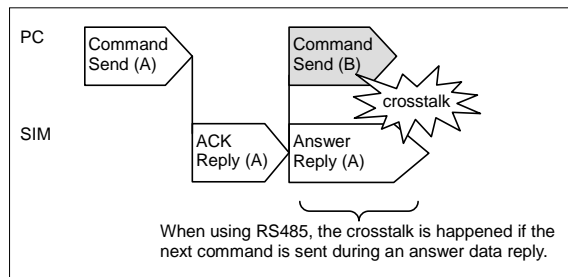

Figure 52 - Example of command sending during answer data reply

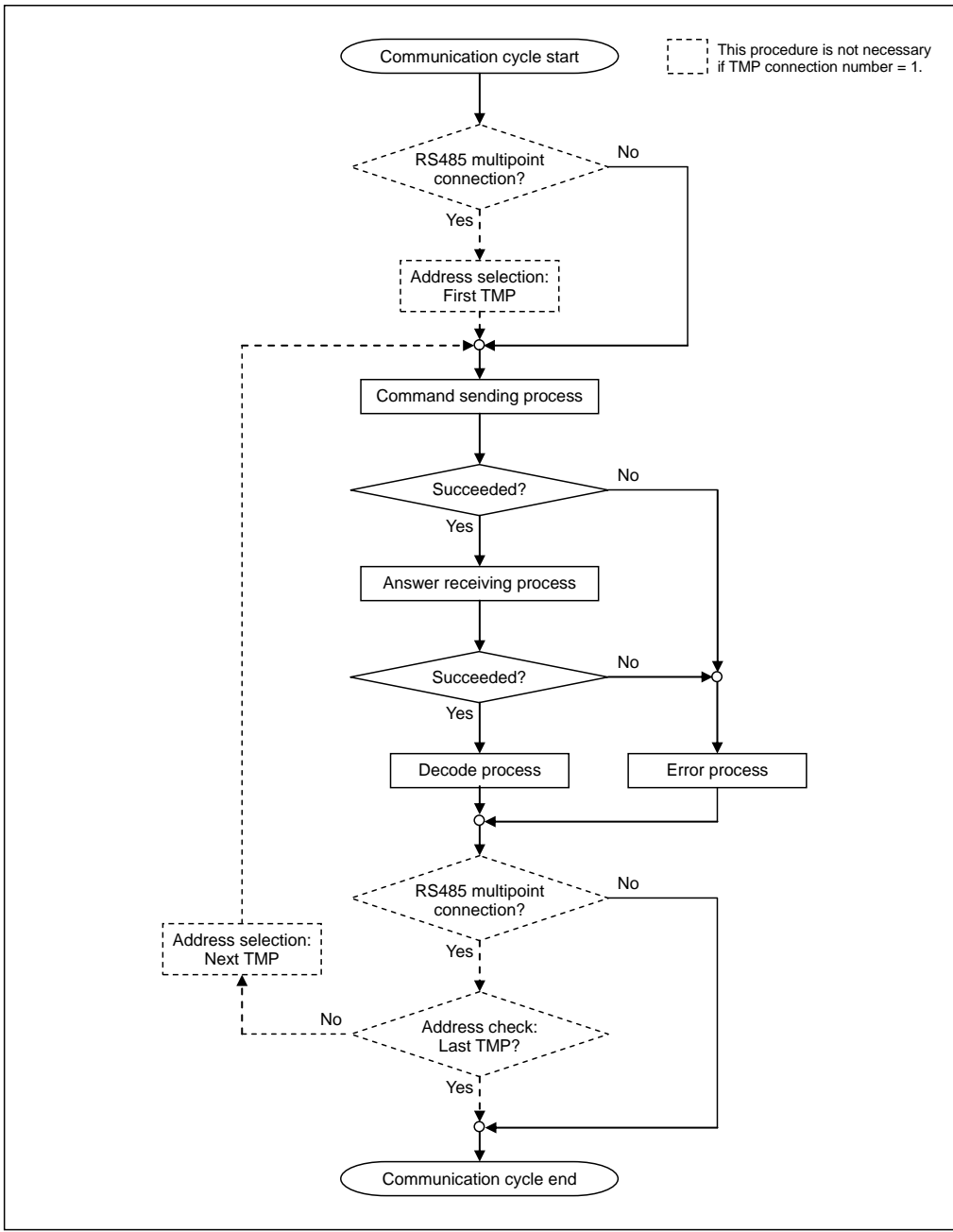

Figure 53 - Example of communication cycle process

STP-IXA3306 Series Turbomolecular Pump

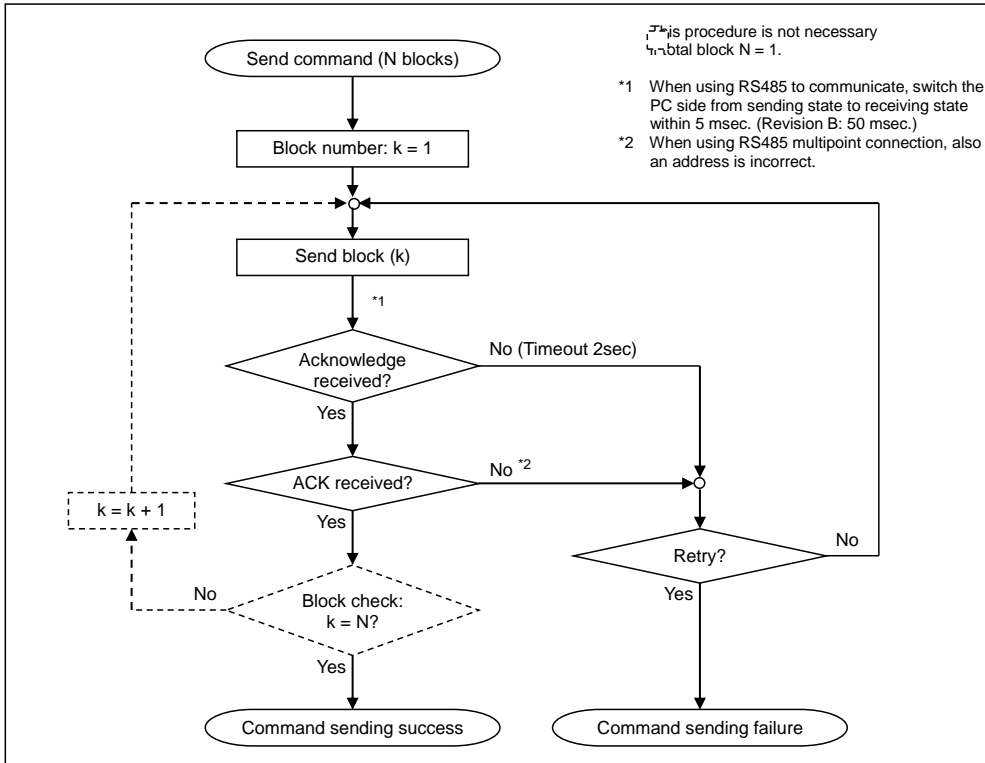

Figure 54 - Example of command sending process

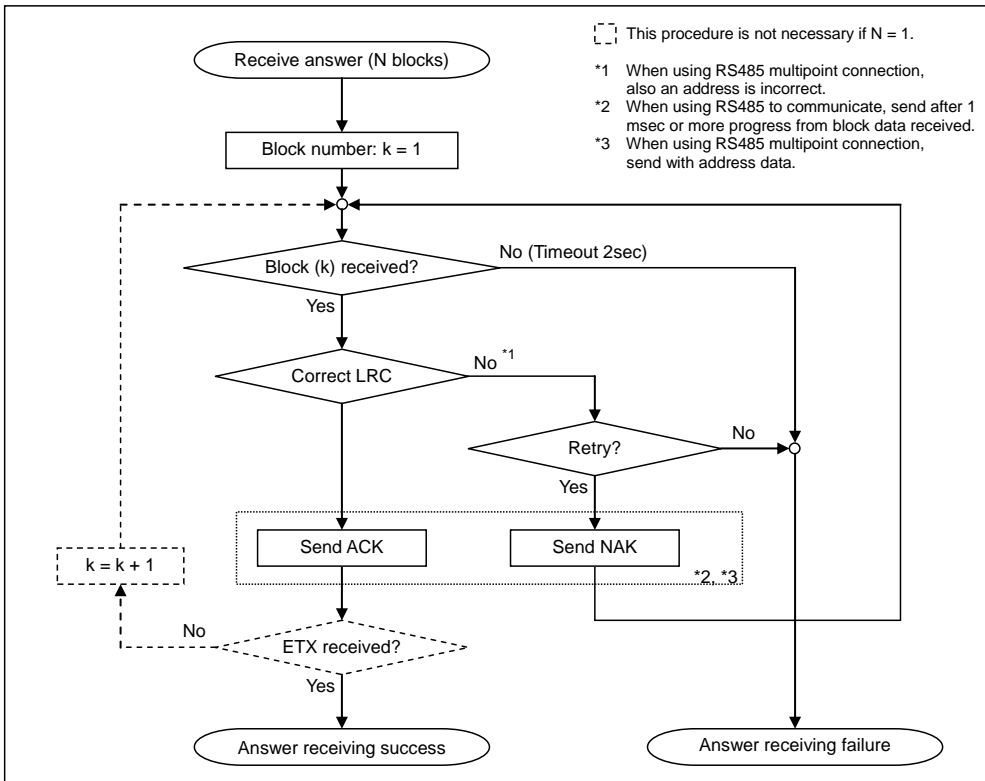

Figure 55 - Example of answer receiving process

5.4 Command specifications

5.4.1 Command list

Function code		Command/Query Name	Function
?	D	ReadMeas	Reads the measured rotational speed.
Sp	E	Command	Sends commands START, STOP, RESET (These commands are valid only when being sent to the serial port which is set as the input operation port.)
?	F	ReadFailMess	Reads the errors being detected.
?	M	ReadModFonct	Reads the pump operation mode and the errors being detected.
?	V	ReadVersion	Reads the software version.
?	c	ReadCounters	Reads serial number, running time and start counter.
?	d	ReadSetPoint	Reads the setting values of the speed set point and the TMS temperature.
?	e	ReadMotorTemp	Reads the measured motor temperature.
?	f	ReadStatus	Reads the various settings. (Remote mode, TMS function, and emergency vent valve).
?	g	ReadEvents	Reads the error record.
Sp	h	SetSpeedSetPoint	Changes the speed set point. *1
?	h	ReadSpeedSetPoint	Reads the speed set point.
?	m	ReadModFonctWithWarning	Reads the pump operation mode, the errors and the warnings being detected
?	[ReadMeasValue	Reads the TMS temperature, motor temperature, motor current, measured rotational speed, and control unit temperature.
?	=	ReadOptionFunc	Reads each setting value of items.
Sp	=	SetOptionFunc	Changes each setting value of items. *1
?	{	ReadCondition	Reads pump model and damage point.
?	}	ReadEventsWithTime	Reads the error record with detection time.
Sp	0	SetOptions	Changes optional function (Second speed option) *1
?	0	ReadOptions	Reads optional function (Second speed option)

Table 34 - Command list

*1 There is an endurance limit of setting changes (no more than 24 times per day for about ten years). If this limit is exceeded, it not only may become impossible to change the setting but can also cause pump failure. Do not make setting changes in excess of this endurance limit.

5.4.2 ReadMeas

Function: Reads the measured rotational speed.

Transmission frame:

PC->SIM

Stx	0	0	1	?	D	Etx	LRC
-----	---	---	---	---	---	-----	-----

SIM->PC

Ack

PC->SIM

Ack

SIM->PC

Stx	0	0	1	Sp	D	Parameter 1 to 2	Etx	LRC
-----	---	---	---	----	---	------------------	-----	-----

Parameter	Item	Data format	Remarks
1	[System reservation]	56-bits hexadecimal coded ASCII	
2	Measured rotational speed (Unit: Hz)	16-bits hexadecimal coded ASCII	

Example:

Measured rotational speed: 01C2_{hex} = 450 Hz = 27,000 rpm

Parameter	1													2				
ASCII	*1	*1	*1	*1	*1	*1	*1	*1	*1	*1	*1	*1	*1	*1	0	1	C	2
HEX															30	31	43	32

*1 System reservation

5.4.3 Command

Function: Sends the pump operation commands START, STOP and RESET. These commands are valid only when being sent to the serial port which is set as the input operation port. Refer to Section 5.4.17, "SetOptionFunc" for the setting method of the input operation port.

Transmission frame:

PC->SIM

Stx	0	0	1	Sp	E	Parameter 1	Etx	LRC
-----	---	---	---	----	---	-------------	-----	-----

SIM->PC

Ack

PC->SIM

Ack

SIM->PC

Stx	0	0	1	#	Etx	LRC
-----	---	---	---	---	-----	-----

Parameter	Item	Data format	Remark
1	Pump operation command	8-bits hexadecimal coded ASCII	Refer to Table 35

Pump operation command	Value
START	1
STOP	2
RESET	4

Table 35 - Pump operation commands

Example:

Pump operation command : RESET operation = 4 = 04_{hex}

Parameter	1	
ASCII	0	4
HEX	30	34

5.4.4 ReadFailMess

Function: Reads the errors being detected. This data is the same data as that of "ReadModFonct" parameter 2 to 82.

Transmission frame:

PC->SIM Stx 0 0 1 ? F Etx LRC

SIM->PC Ack

PC->SIM Ack

SIM->PC Stx 0 0 1 Sp F Parameter 1 to 81*1 Etx LRC

Parameter	Item	Data format	Remarks
1	The number of error	8-bits hexadecimal coded ASCII	Up to 80 errors *1
2 to 81 *1	Error 1	8-bits hexadecimal coded ASCII	*2
	
	Error 80 *1	8-bits hexadecimal coded ASCII	

*1 The maximum number of errors may differ depending upon the software version of the STP pump. It is recommended that an application be designed as variable-length data. In Revision C, the case of the error detection is less than or equal 32 and Parameter length is 33.

*2 Value corresponding to the error message is transmitted, (refer to Table 36 and Table 37). The most recent error has the largest parameter number. When the number of errors being detected is under the maximum number, the value of parameter that is larger than the number of errors being detected is set to 0.

Example:

The number of error : 02_{hex} = 2 errors
 Error 1 : 0D_{hex} = 13 = Disturbance Xh
 Error 2 : 0F_{hex} = 15 = Disturbance Xb
 Error 3 to 80 : 00_{hex} = No error detected

Parameter	1	2	3	4	5	6	7	8	9	10
ASCII	0 2	0 D	0 F	0 0	0 0	0 0	0 0	0 0	0 0	0 0
HEX	30 32	30 44	30 46	30 30	30 30	30 30	30 30	30 30	30 30	30 30

Parameter	11	12	13	[Omitted]					
ASCII	0 0	0 0	0 0	68	69	70	71	72	73
HEX	30 30	30 30	30 30	0 0	0 0	0 0	0 0	0 0	0 0
				30 30	30 30	30 30	30 30	30 30	30 30

Parameter	74	75	76	77	78	79	80	81
ASCII	0 0	0 0	0 0	0 0	0 0	0 0	0 0	0 0
HEX	30 30	30 30	30 30	30 30	30 30	30 30	30 30	30 30



STP-iXA3306 Series Turbomolecular Pump

Error message	Value
Ram Error	0
[System reservation]	1
TMS Higher Temp	2
[System reservation]	3
[System reservation]	4
Power Failure	5
Power Supply Fail	6
Overspeed 1	7
DRV Overvoltage	8
[System reservation]	9
CNT Overheat 1	10
DRV Overcurrent	11
DRV Overload	12
Disturbance X_H	13
Disturbance Y_H	14
Disturbance X_B	15
Disturbance Y_B	16
Disturbance Z	17
MOTOR Overheat	18
[System reservation]	19
CNT Overheat 2	20
[System reservation]	21
[System reservation]	22
[System reservation]	23
DRV Com. Failure	24
WARNING: 1 st Damage Limit	25 *1
2 nd Damage Limit	26
[System reservation]	27
Speed Pulse Lost	28
Overspeed 2	29
Overspeed 3	30
M_Temp Lost	31
TMS Lower Temp	32

Error message	Value
AMB Com. Failure	33
[System reservation]	34
TMS Sensor Lost	35
[System reservation]	36
[System reservation]	37
[System reservation]	38
[System reservation]	39
[System reservation]	40
[System reservation]	41
[System reservation]	42
WARNING: Imbalance X_H	43 *1
WARNING: Imbalance X_B	44 *1
WARNING: Imbalance Z	45 *1
[System reservation]	46
[System reservation]	47
[System reservation]	48
[System reservation]	49
Driver Failure	50
[System reservation]	51
[System reservation]	52
[System reservation]	53
[System reservation]	54
[System reservation]	55
[System reservation]	56
[System reservation]	57
[System reservation]	58
Acc Malfunction	59
[System reservation]	60
[System reservation]	61
[System reservation]	62
[System reservation]	63
[System reservation]	64
[System reservation]	65

Table 36 - Error message values

STP-iXA3306 Series Turbomolecular Pump

Error message	Value
[System reservation]	66
[System reservation]	67
[System reservation]	68
[System reservation]	69
[System reservation]	70
[System reservation]	71
Aberrant Brake	72
Aberrant Accel	73
[System reservation]	74
[System reservation]	75
Inordint Current	76
FAN Trouble	77
Serial Com. Fail	78 * ²
[System reservation]	79
[System reservation]	80

Error message	Value
[System reservation]	81
[System reservation]	82
[System reservation]	83
[System reservation]	84
[System reservation]	85
[System reservation]	86
[System reservation]	87
Overspeed 4	88
[System reservation]	89
CNT Overheat 3	90
[System reservation]	91
[System reservation]	92
[System reservation]	93
WARNING: C/U Restart	94

Table 37 - Error message values (continued)

*1 CAUTION or WARNING message. It is not a state of failure. Refer to Section 7 for details. The STP pump will continue to operate after one of these messages is displayed. It is recommended that an application be designed with this in consideration.

*2 When the setting value of serial communication timeout is 0, the error 78 is disabled (not detected).

5.4.5 ReadModFonct

Function: Reads the pump operation mode and the errors being detected. The data of errors being detected reads the same data as that of "ReadFailMess".

Transmission frame:

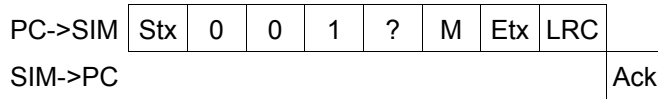

Parameter	Item	Data format	Remarks
1	Pump operation mode	8-bits hexadecimal coded ASCII	Refer to Table 38
2	The number of error	8-bits hexadecimal coded ASCII	Up to 80 errors ^{*1}
3 to 82 ^{*1}	Error 1	8-bits hexadecimal coded ASCII	^{*2}
	
	Error 80 ^{*1}	8-bits hexadecimal coded ASCII	

^{*1} The maximum number of errors may differ depending upon the software version of the STP pump. It is recommended that an application be designed as variable-length data. In Revision C, the case of the error detection is less than or equal 32 and Parameter length is 34.

^{*2} Value corresponding to the error message is transmitted (refer to Table 36 and Table 37). The most recent error has the largest parameter number. When the number of errors being detected is under the maximum number, the value of parameter that is larger than the number of errors being detected is set to 0.



STP-iXA3306 Series Turbomolecular Pump

Pump operation mode	Value
Levitation	1
No Levitation	2
Acceleration	3
Normal	4
Deceleration (Brake)	5
Autotest	6
Tuning	7
Tuning Complete	8
[System Reservation]	9, 10, 11

Table 38 - Pump operation mode

Example:

- Pump operation mode : 01_{hex} = 1 = Levitation
- The number of error : 02_{hex} = 2 errors
- Error 1 : 0D_{hex} = 13 = Disturbance Xh
- Error 2 : 0F_{hex} = 15 = Disturbance Xb
- Error 3 to 80 : 00_{hex} = No error detected

Parameter	1		2		3		4		5		6		7		8		9		10		11	
ASCII	0	1	0	2	0	D	0	F	0	0	0	0	0	0	0	0	0	0	0	0	0	0
HEX	30	31	30	32	30	44	30	46	30	30	30	30	30	30	30	30	30	30	30	30	30	30

Parameter	12		13		[Omitted]	68		69		70		71		72		73		74		75	
ASCII	0	0	0	0		0	0	0	0	0	0	0	0	0	0	0	0	0	0	0	0
HEX	30	30	30	30		30	30	30	30	30	30	30	30	30	30	30	30	30	30	30	30

Parameter	76		77		78		79		80		81		82	
ASCII	0	0	0	0	0	0	0	0	0	0	0	0	0	0
HEX	30	30	30	30	30	30	30	30	30	30	30	30	30	30

5.4.6 ReadVersion

Function: Read the software version.

Transmission frame:

PC->SIM Stx 0 0 1 ? V Etx LRC

SIM->PC Ack

PC->SIM Ack

SIM->PC Stx 0 0 1 Sp V Parameter 1 to 24 Etx LRC

Parameter	Item	Data format	Remarks
1 to 16	Control unit software version	8-bits hexadecimal coded ASCII	
17 to 20	Motor driver software version	4-bits ASCII character	Ver.1.2 = 0120
21 to 24	AMB software version	4-bits ASCII character	Ver.3.4 = 0340

Example:

Control unit software version : 36335F4120312E3020202020202020_{hex} = 63_A 1.0

Motor driver software version : 0120_{hex} = 1.2

DSP software version : 0340_{hex} = 3.4

Parameter	1	2	3	4	5	6	7	8	9	10
	"6"	"3"	"_"	"A"	" "	"1"	"."	"0"	" "	" "
ASCII	3 6	3 3	5 F	4 1	2 0	3 1	2 E	3 0	2 0	2 0
HEX	33 36	33 33	35 46	34 31	32 30	33 31	32 45	33 30	32 30	32 30

Parameter	11	12	13	14	15	16	17	18	19	20	21	22	23	24
	" "	" "	" "	" "	" "	" "	/	/	/	/	/	/	/	/
ASCII	2 0	2 0	2 0	2 0	2 0	2 0	0 1	2 0	0 3	4 0				
HEX	32 30	32 30	32 30	32 30	32 30	32 30	30 31	32 30	30 33	34 30				

5.4.7 ReadCounters

Function: Reads serial number, running time and start counter.

Transmission frame:

PC->SIM

Stx	0	0	1	?	c	Etx	LRC
-----	---	---	---	---	---	-----	-----

SIM->PC

Ack

PC->SIM

Ack

SIM->PC

Stx	0	0	1	Sp	c	Parameter 1 to 23	Etx	LRC
-----	---	---	---	----	---	-------------------	-----	-----

Parameter	Item	Data format	Remarks
1 to 10	Control unit serial number	4-bits ASCII character	
11 to 20	Pump serial number	4-bits ASCII character	
21	Pump running time (Unit: minute)	32-bits hexadecimal coded ASCII	
22	Control unit running time (Unit: minute)	32-bits hexadecimal coded ASCII	
23	Start counter	32-bits hexadecimal coded ASCII	

Example:

Control unit serial number : 12345

Pump serial number : 6789A

Pump running time : 0000003C_{hex} = 60 minutes = 1 hour

Control unit running time : 0000028C_{hex} = 652 minutes = 10 hours and 52 minutes

Start counter : 00000064_{hex} = 100 times

Parameter	1	2	3	4	5	6	7	8	9	10	11	12	13	14	15	16	17	18	19	20	
ASCII	1	2	3	4	5						6	7	8	9	A						
HEX	31	32	33	34	35	20	20	20	20	20	36	37	38	39	41	20	20	20	20	20	20

Parameter	21								22								23									
ASCII	0	0	0	0	0	0	3	C	0	0	0	0	0	2	8	C	0	0	0	0	0	0	0	0	6	4
HEX	30	30	30	30	30	30	33	43	30	30	30	30	30	32	38	43	30	30	30	30	30	30	30	30	36	34

5.4.8 ReadSetPoint

Function: Reads the setting value of the "Speed Set Point" and TMS temperature. The "Speed Set Point" data is the same data as that of "ReadSpeedSetPoint".

Transmission frame:

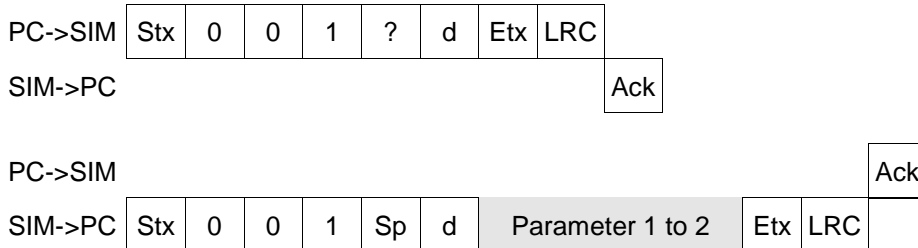

Parameter	Item	Data format	Remarks
1	Speed Set Point (Unit: Hz)	16-bits hexadecimal coded ASCII	
2	TMS temperature setting (Unit: °C)	16-bits hexadecimal coded ASCII	

Example:

Speed Set Point : 01F4_{hex} = 500 Hz = 30,000 rpm

TMS temperature setting : 0046_{hex} = 70 °C

Parameter	1				2			
ASCII	0	1	F	4	0	0	4	6
HEX	30	31	46	34	30	30	34	36

5.4.9 ReadMotorTemp

Function: Reads the measured motor temperature.

Transmission frame:

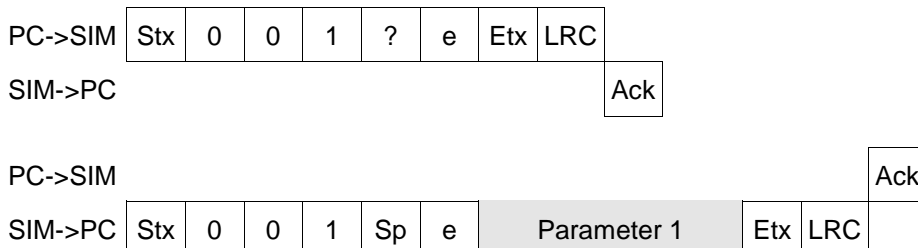

Parameter	Item	Data format	Remark
1	Motor temperature (Unit: °C)	16-bits hexadecimal coded ASCII	

Example:

Motor temperature : 0014_{hex} = 20 °C (68 °F)

Parameter	1			
ASCII	0	0	1	4
HEX	30	30	31	34

5.4.10 ReadStatus

Function: Reads various settings (Remote mode, TMS function, Emergency vent valve).

Transmission frame:

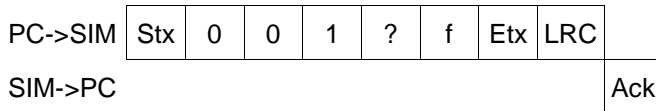

Parameter	Item	Data format	Remarks
1	Remote mode setting	8-bits hexadecimal coded ASCII	Refer to Table 39
2	TMS function setting	8-bits hexadecimal coded ASCII	00 _{hex} : ENABLE Excluding 00 _{hex} : DISABLE
3	[System reservation]	8-bits hexadecimal coded ASCII	
4	Emergency vent valve setting	8-bits hexadecimal coded ASCII	00 _{hex} : ENABLE Excluding 00 _{hex} : DISABLE

Remote mode	Value
I/O Remote (X2)	1
COM1 (X3)	2
COM2 (X4)	5
COM3 (X5 STP-Link)	6
[System reservation]	3, 4

Table 39 - Remote mode

Example:

Remote mode setting : 01_{hex} = I/O Remote
 TMS function setting : 00_{hex} = ENABLE
 Emergency vent valve setting : FF_{hex} = DISABLE

Parameter	1		2		3		4	
ASCII	0	1	0	0	*1	*1	F	F
HEX	30	31	30	30			46	46

*1 System reservation

5.4.11 ReadEvents

Function: Reads the "Error Record". It has the most recent 10 errors that have been detected.

Transmission frame:

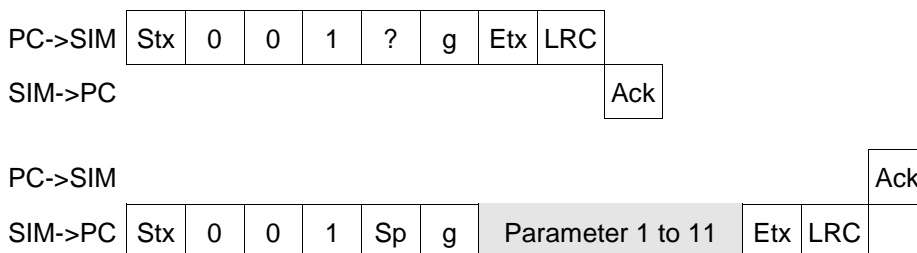

Parameter	Item	Data format	Remarks
1	The number of "Error Record"	8-bits hexadecimal coded ASCII	Up to 10 errors
2 to 11	Error Record 1 to Error Record 10	8-bits hexadecimal coded ASCII	*1

*1 Value corresponding to the error message is transmitted (refer to Table 36 and Table 37). The most recent error has the smallest parameter number. When the number of errors being detected is under the maximum number, the value of parameter that is larger than the number of errors has been detected is set to 0.

Example:

When 3 errors have been detected in the past;

- The number of "Error Record" : 03_{hex} = 3 errors
- Error Record 1 : 0F_{hex} = 15 = Disturbance Xb
- Error Record 2 : 0D_{hex} = 13 = Disturbance Xh
- Error Record 3 : 12_{hex} = 18 = T.Cable Disconnected
- Error Record 4 to 10 : 00_{hex} = No error recorded

Parameter	1	2	3	4	5	6	7	8	9	10	11										
ASCII	0	3	0	F	0	D	1	2	0	0	0	0	0	0	0	0	0	0	0	0	0
HEX	30	33	30	46	30	44	31	32	30	30	30	30	30	30	30	30	30	30	30	30	30

5.4.12 SetSpeedSetPoint

Function: Changes the "Speed Set Point" value. This value can be changed the range from 13,500 to 27,000 rpm. The threshold value of the illumination pattern of the "ROTATION" LED is fixed. It is not changed even if the setting value of the rotational speed is changed.

CAUTION

There is an endurance limit of setting changes (no more than 24 times per day for about ten years). If this limit is exceeded, it not only may become impossible to change the setting but can also cause pump failure. Do not make setting changes in excess of this endurance limit.

Transmission frame:

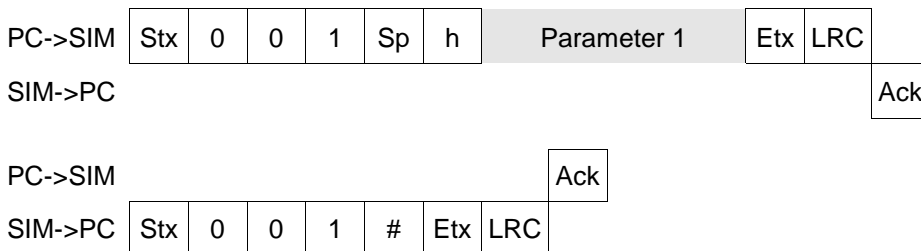

Parameter	Items	Data format	Remark
1	Speed Set Point (Unit: Hz)	16-bits hexadecimal coded ASCII	*1

*1 When the value set to the parameter is larger than the upper limit, it is automatically set to the upper limit. When the value set to the parameter is smaller than the lower limit, it is automatically set to the lower limit.

Example:

Speed Set Point : 0190_{hex} = 400 Hz = 24,000 rpm

Parameter	1			
ASCII	0	1	9	0
HEX	30	31	39	30

5.4.13 ReadSpeedSetPoint

Function: Reads the "Speed Set Point" value. This value is the same as "ReadSetPoint" parameter 1 (Speed Set Point).

Transmission frame:

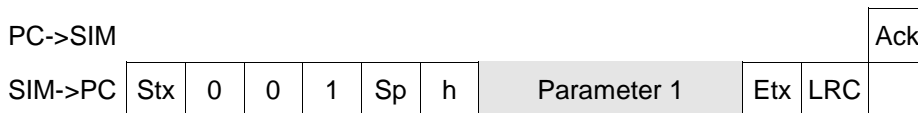
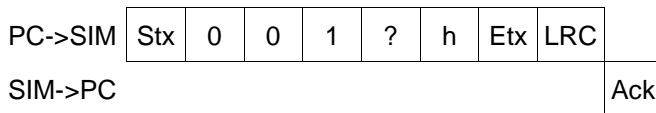

Parameter	Item	Data format	Remark
1	Speed Set Point (Unit: Hz)	16-bits hexadecimal coded ASCII	

Example:

Speed Set Point : 012C_{hex} = 300 Hz = 18,000 rpm

Parameter	1			
ASCII	0	1	2	C
HEX	30	31	32	43

5.4.14 ReadModFonctWithWarning

Function: Reads the pump operation mode, errors and warnings being detected.

Transmission Frame:

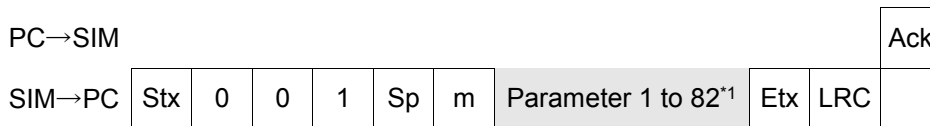
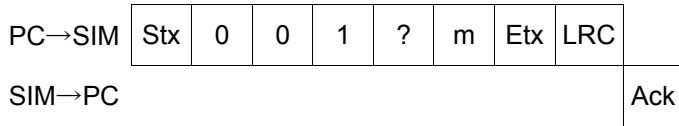

Parameter	Item	Data format	Remark
1	Pump operation mode	8-bits hexadecimal coded ASCII	See Table 37
2	WARNING being detected	16-bits hexadecimal coded ASCII	See Table 40
3	The number of errors detected	8-bits hexadecimal coded ASCII	Up to 79 errors ^{*1}
4 to 82 ^{*1}	Error 1	8-bits hexadecimal coded ASCII	*2
	...		
	Error 79 ^{*1}	8-bits hexadecimal coded ASCII	

*1 The maximum number of errors may differ depending upon the software version of the STP pump. It is recommended that an application be designed as variable-length data. In Revision C, the case of the error detection is less than or equal 32 and Parameter length is 35.

*2 Value corresponding to the error message is transmitted. (see Table 36 and Table 37)

The recent error has the largest parameter number. When the number of errors being detected is under the maximum number, the value of parameter that is larger than the number of errors being detected is set to 0.

STP-iXA3306 Series Turbomolecular Pump

Bit	Warning message	16-bits hex value
0	[System reservation]	0001
1	WARNING: Second Damage Limit	0002
2	WARNING: First Damage Limit	0004
3	WARNING: Imbalance X_H	0008
4	WARNING: Imbalance X_B	0010
5	WARNING: Imbalance Z	0020
6	WARNING: Pump Run Time Over	0040
7	WARNING: Pump Overload	0080
8	[System reservation]	0100
9	[System reservation]	0200
10	[System reservation]	0400
11	[System reservation]	0800
12	[System reservation]	1000
13	[System reservation]	2000
14	[System reservation]	4000
15	[System reservation]	8000

Table 40 - Warning value bit assign



STP-iXA3306 Series Turbomolecular Pump

Example:

- Pump operation mode : 01_{hex} = 1 = Levitation
- WARNING being detected : 000C_{hex} = 0004_{hex} OR 0080_{hex} =
"WARNING: First Damage Limit" and
"WARNING: Imbalance X_H"
- The number of error : 02_{hex} = 2 errors
- Error 1 : 0D_{hex} = 13 = Disturbance Xh
- Error 2 : 0F_{hex} = 15 = Disturbance Xb
- Error 3 to 79 : 00_{hex} = No error detected

Parameter	1		2			3		4		5		6		7		8		9		10		
ASCII	0	1	0	0	0	C	0	2	0	D	0	F	0	0	0	0	0	0	0	0	0	0
HEX	30	31	30	30	30	43	30	32	30	44	30	46	30	30	30	30	30	30	30	30	30	30

Parameter	11		12		13		14		15		[Omitted]	70		71		72		73		74			
ASCII	0	0	0	0	0	0	0	0	0	0		0	0	0	0	0	0	0	0	0	0	0	0
HEX	30	30	30	30	30	30	30	30	30	30		30	30	30	30	30	30	30	30	30	30	30	30

Parameter	75		76		77		78		79		80		81		82	
ASCII	0	0	0	0	0	0	0	0	0	0	0	0	0	0	0	0
HEX	30	30	30	30	30	30	30	30	30	30	30	30	30	30	30	30

5.4.15 ReadMeasValue

Function: Reads the TMS temperature, motor temperature, motor current, measured rotational speed, and control unit temperature. The motor temperature value is the same temperature as "ReadMotorTemp". The measured rotational speed value is the same as "ReadMeas" parameter 2 (Measured rotational speed).

Transmission frame:

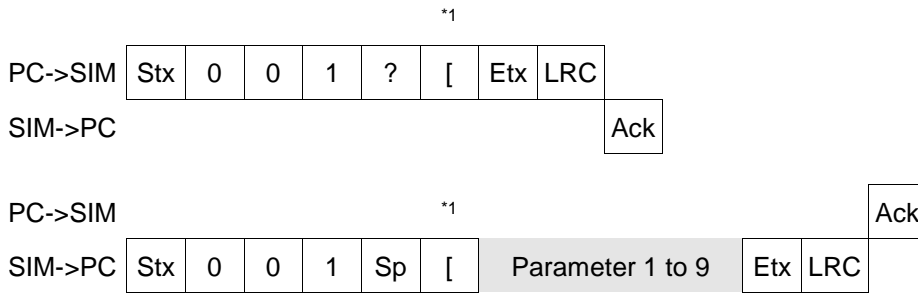

*1 The HEX code of ASCII character '[' is "5B".

Parameter	Item	Data format	Remark
1	[System reservation]	120-bits hexadecimal coded ASCII	
2	TMS temperature (Unit °C)	16-bits hexadecimal coded ASCII	
3	Motor temperature (Unit °C)	16-bits hexadecimal coded ASCII	
4	[System reservation]	8-bits hexadecimal coded ASCII	
5	Motor current (Unit: 0.1 A)	8-bits hexadecimal coded ASCII	
6	[System reservation]	24-bits hexadecimal coded ASCII	
7	Measured rotational speed (Unit: Hz)	16-bits hexadecimal coded ASCII	
8	[System reservation]	48-bits hexadecimal coded ASCII	
9	Control unit temperature (Unit: °C)	16-bits hexadecimal coded ASCII	



STP-iXA3306 Series Turbomolecular Pump

Example:

TMS temperature: 0046_{hex} = 70 °C (158°F)
 Motor temperature: 0014C_{hex} = 20 °C (68°F)
 Motor current: 19_{hex} = 2.5A
 Measured rotational speed: 01C2_{hex} = 450 Hz = 27,000 rpm
 Control unit temperature: 0032_{hex} = 50 °C

Parameter	1																
ASCII	*1	*1	*1	*1	*1	*1	*1	*1	*1	*1	*1	*1	*1	*1	*1	*1	*1
HEX																	

Parameter	1											2			
ASCII	*1	*1	*1	*1	*1	*1	*1	*1	*1	*1	*1	0	0	4	6
HEX												30	30	34	36

Parameter	3				4		5		6						7			
ASCII	0	0	1	4	*1	*1	1	9	*1	*1	*1	*1	*1	*1	0	1	C	2
HEX	30	30	31	34			31	39							30	31	43	32

Parameter	8											9			
ASCII	*1	*1	*1	*1	*1	*1	*1	*1	*1	*1	*1	0	0	3	2
HEX												30	30	33	32

*1 System reservation

5.4.16 ReadOptionFunc

Function: Reads the setting value of the input operation port, warning function, and serial communication time out.

Transmission frame:

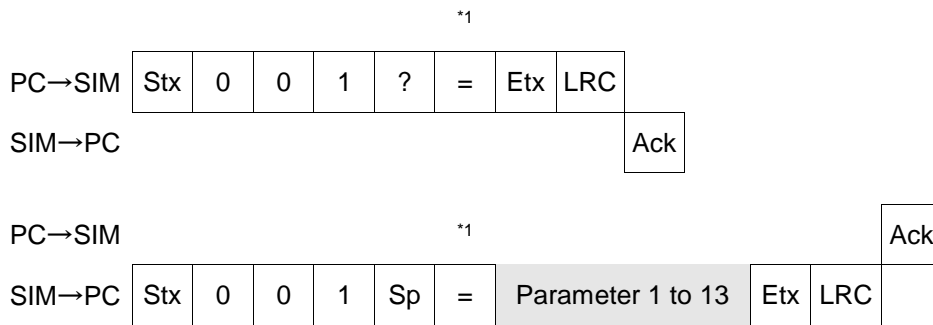

*1 The HEX code of ASCII character '=' is "3D".

Parameter	Item	Data format	Remarks
1	Input operation port setting	8-bits hexadecimal coded ASCII	
2	TMS Option Enable/Disable setting	8-bits hexadecimal coded ASCII	
3	[System reservation]	48-bits hexadecimal coded ASCII	
4	Second Damage Limit Option Enable/Disable setting	8-bits hexadecimal coded ASCII	
5	First Damage Limit Warning Enable/Disable setting	8-bits hexadecimal coded ASCII	
6	Pump Runtime Over Warning Enable/Disable setting	8-bits hexadecimal coded ASCII	
7	Pump Runtime Over Warning Hours setting (×100 hours)	32-bits hexadecimal coded ASCII	
8	Imbalance Warning Enable/Disable setting	8-bits hexadecimal coded ASCII	
9	Pump Overload Warning Enable/Disable setting	8-bits hexadecimal coded ASCII	
10	Pump Overload Warning Motor current setting	16-bits hexadecimal coded ASCII	0.1 % step
11	Pump Overload Warning Rotational speed setting	16-bits hexadecimal coded ASCII	0.1 % step



STP-iXA3306 Series Turbomolecular Pump

Parameter	Item	Data format	Remarks
12	Serial communication time out setting (Unit: sec.)	16-bits hexadecimal coded ASCII	60 sec. step
13	[System reservation]	88-bits hexadecimal coded ASCII	

Parameter	Item	Setting range
1	Input operation port setting	I/O REMOTE (X2): 01 _{hex} COM1 (X3): 02 _{hex} COM2 (X4): 05 _{hex} COM3 (X5 STP-Link): 06 _{hex}
2	TMS Option Enable/Disable setting	00 _{hex} : ENABLE FF _{hex} : DISABLE
4	Second Damage Limit Option Enable/Disable setting	00 _{hex} : ENABLE FF _{hex} : DISABLE
5	First Damage Limit Warning Enable/Disable setting	00 _{hex} : ENABLE FF _{hex} : DISABLE
6	Pump Runtime Over Warning Enable/Disable setting	00 _{hex} : ENABLE FF _{hex} : DISABLE
7	Pump Runtime Over Warning Hours setting	0 to 1,000×100 hours (00000000 _{hex} to 000003E8 _{hex})
8	Imbalance Warning Enable/Disable setting	00 _{hex} : ENABLE FF _{hex} : DISABLE
9	Pump Overload Warning Enable/Disable setting	00 _{hex} : ENABLE FF _{hex} : DISABLE
10	Pump Overload Warning Motor current setting	0 to 1,000×0.1 % (0000 _{hex} to 03E8 _{hex})
11	Pump Overload Warning Rotational speed setting	0 to 1,000×0.1 % (0000 _{hex} to 03E8 _{hex})
12	Serial communication time out setting	0 to 30,000sec. (0000 _{hex} to 7530 _{hex}) Round down to the 60 seconds Set to 0 to disable function

Table 41 - Parameter setting value



STP-iXA3306 Series Turbomolecular Pump

Example:

- 1. Input operation port: 01_{hex} = I/O REMOTE
- 2. TMS Option: FF_{hex} = DISABLE
- 4. Second Damage Limit Option: 00_{hex} = ENABLE
- 5. First Damage Limit Warning: 00_{hex} = ENABLE
- 6. Pump Runtime Over Warning: FF_{hex} = DISABLE
- 7. Pump Runtime Over Warning hours: 000003E8_{hex} = 1,000 (x100 hours)
- 8. Imbalance Warning: 00_{hex} = ENABLE
- 9. Pump Overload Warning: FF_{hex} = DISABLE
- 10. Pump Overload Warning Motor current: 03E8_{hex} = 1,000 (x0.1%)
- 11. Pump Overload Warning Rotational speed: 0000_{hex} = 0 (x0.1%)
- 12. Serial communication time out: 003C_{hex} = 60 sec.

Parameter	1		2		3										4		5			
ASCII	0	1	F	F	*1	*1	*1	*1	*1	*1	*1	*1	*1	*1	*1	*1	0	0	0	0
HEX	30	31	46	46													30	30	30	30

Parameter	6		7										8	
ASCII	F	F	0	0	0	0	0	3	E	8	0	0		
HEX	46	46	30	30	30	30	30	33	45	38	30	30		

Parameter	9		10				11				12				13					
ASCII	F	F	0	3	E	8	0	0	0	0	0	0	3	C	*1	*1	*1	*1	*1	*1
HEX	46	46	30	33	45	38	30	30	30	30	30	30	33	43						

Parameter	13												
ASCII	*1	*1	*1	*1	*1	*1	*1	*1	*1	*1	*1	*1	*1
HEX													

*1 System reservation.

5.4.17 SetOptionFunc

Function: Changes the setting value of the input operation port, warning function, and serial communication time out.

CAUTION

There is an endurance limit of setting changes (no more than 24 times per day for about ten years). If this limit is exceeded, it not only may become impossible to change the setting but can also cause pump failure. Do not make setting changes in excess of this endurance limit.

Transmission frame:

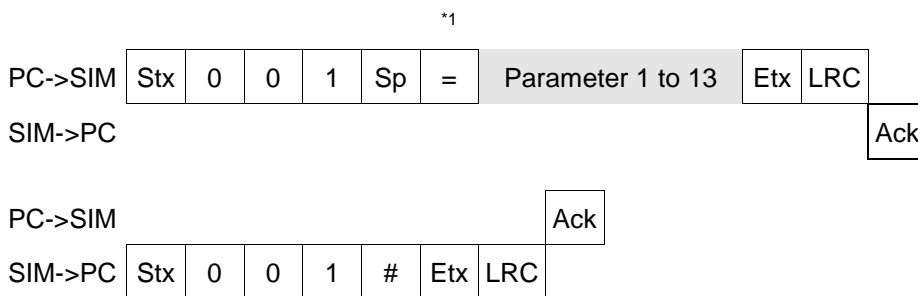

*1 The HEX code of ASCII character '=' is "3D".

Parameter	Item	Data format	Remarks
1	Input operation port setting	8-bits hexadecimal coded ASCII	Default 01 _{hex} (I/O REMOTE)
2	TMS Option Enable/Disable setting	8-bits hexadecimal coded ASCII	Default FF _{hex} (DISABLE)
3	[System reservation]	48-bits hexadecimal coded ASCII	*1
4	Second Damage Limit Option Enable/Disable setting	8-bits hexadecimal coded ASCII	Default 00 _{hex} (ENABLE)
5	First Damage Limit Warning Enable/Disable setting	8-bits hexadecimal coded ASCII	Default 00 _{hex} (ENABLE)
6	Pump Runtime Over Warning Enable/Disable setting	8-bits hexadecimal coded ASCII	Default FF _{hex} (DISABLE)
7	Pump Runtime Over Warning Hours setting (×100 hours)	32-bits hexadecimal coded ASCII	Default 00000000 _{hex}
8	Imbalance Warning Enable/Disable setting	8-bits hexadecimal coded ASCII	Default 00 _{hex} (ENABLE)
9	Pump Overload Warning Enable/Disable setting	8-bits hexadecimal coded ASCII	Default FF _{hex} (DISABLE)
10	Pump Overload Warning Motor current setting	16-bits hexadecimal coded ASCII	Default 03E8 _{hex} (100.0%)



STP-iXA3306 Series Turbomolecular Pump

Parameter	Item	Data format	Remarks
11	Pump Overload Warning Rotational speed setting	16-bits hexadecimal coded ASCII	Default 0000 _{hex} (0.0%)
12	Serial communication time out setting (Unit: sec.)	16-bits hexadecimal coded ASCII	Default 003C _{hex} (60 sec.)
13	[System reservation]	88-bits hexadecimal coded ASCII	*2

*1 Assign the parameter value the reading data of ReadOptionFunc (?=) or FFFF32003CFF_{hex}.

*2 Assign the parameter value the reading data of ReadOptionFunc (?=) or F_{hex}.

Refer to Table 41, "Parameter setting value" for each parameter setting value. The value is not reflected when a parameter is out of a setting range.

Example:

- 1. Input operation port: 01_{hex} = I/O REMOTE
- 2. TMS Option: FF_{hex} = DISABLE
- 4. Second Damage Limit Option: 00_{hex} = ENABLE
- 5. First Damage Limit Warning: 00_{hex} = ENABLE
- 6. Pump Runtime Over Warning: FF_{hex} = DISABLE
- 7. Pump Runtime Over Warning hours: 000003E8_{hex} = 1,000 (×100 hours)
- 8. Imbalance Warning: 00_{hex} = ENABLE
- 9. Pump Overload Warning: FF_{hex} = DISABLE
- 10. Pump Overload Warning Motor current: 03E8_{hex} = 1,000 (×0.1%)
- 11. Pump Overload Warning Rotational speed: 0000_{hex} = 0 (×0.1%)
- 12. Serial communication time out: 003C_{hex} = 60 sec.

Parameter	1		2		3										4		5			
	0	1	F	F	*1	*1	*1	*1	*1	*1	*1	*1	*1	*1	*1	*1	0	0	0	0
ASCII	0	1	F	F	*1	*1	*1	*1	*1	*1	*1	*1	*1	*1	*1	*1	0	0	0	0
HEX	30	31	46	46													30	30	30	30

Parameter	6		7								8	
	F	F	0	0	0	0	0	3	E	8	0	0
ASCII	F	F	0	0	0	0	0	3	E	8	0	0
HEX	46	46	30	30	30	30	30	33	45	38	30	30

Parameter	9		10				11				12				13					
	F	F	0	3	E	8	0	0	0	0	0	0	3	C	*2	*2	*2	*2	*2	*2
ASCII	F	F	0	3	E	8	0	0	0	0	0	0	3	C	*2	*2	*2	*2	*2	*2
HEX	46	46	30	33	45	38	30	30	30	30	30	30	33	43						

STP-iXA3306 Series Turbomolecular Pump

Parameter	13														
ASCII	*2	*2	*2	*2	*2	*2	*2	*2	*2	*2	*2	*2	*2	*2	*2
HEX															

*1 Assign the parameter value the reading data of ReadOptionFunc (?=) or FFFF32003CFFhex.

*2 Assign the parameter value the reading data of ReadOptionFunc (?=) or Fhex.

5.4.18 ReadCondition

Function: Reads the pump model and damage point.

Transmission frame:

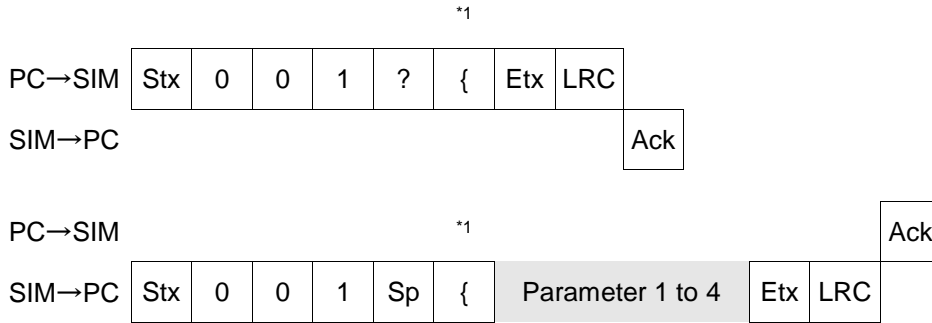

*1 The HEX code of ASCII character ' {' is "7B".

Parameter	Item	Data format	Remarks
1	Pump model	160-bits hexadecimal coded ASCII	
2	[System reservation]	32-bits hexadecimal coded ASCII	
3	Damage point	16-bits hexadecimal coded ASCII	
4	[System reservation]	64-bits hexadecimal coded ASCII	



STP-iXA3306 Series Turbomolecular Pump

Example:

1. Pump model:
5354502D695841333330362020202020202020_{hex}
= STP-iXA3306
3. Damage point:
32_{hex} = 50

Parameter	1																			
	"S"		"T"		"P"		"_"		"I"		"X"		"A"		"3"		"3"		"0"	
ASCII	5	3	5	4	5	0	2	D	6	9	5	8	4	1	3	3	3	3	3	0
HEX	35	33	35	34	35	30	32	44	36	39	35	38	34	31	33	33	33	33	33	30

Parameter	1																			
	"6"		""		""		""		""		""		""		""		""		""	
ASCII	3	6	2	0	2	0	2	0	2	0	2	0	2	0	2	0	2	0	2	0
HEX	33	36	32	30	32	32	32	30	32	30	32	30	32	30	32	30	32	30	32	30

Parameter	2								3				4							
ASCII	*1	*1	*1	*1	*1	*1	*1	*1	0	0	3	2	*1	*1	*1	*1	*1	*1	*1	*1
HEX									30	30	33	32								

Parameter	4							
ASCII	*1	*1	*1	*1	*1	*1	*1	*1
HEX								

*1 System reservation

5.4.19 ReadEventsWithTime

Function: Reads the "Error Record" with detection time.

Transmission frame:

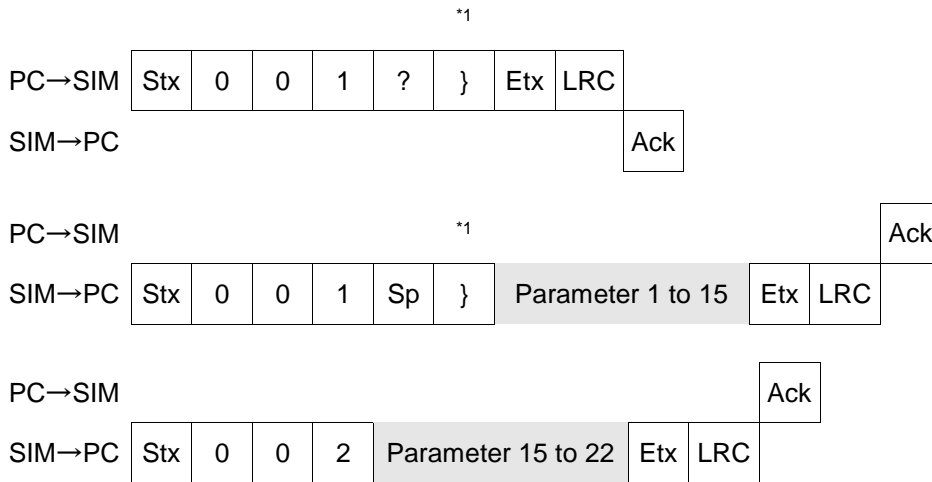

*1 The HEX code of ASCII character '}' is "7D".

Parameter	Item	Data format	Remarks
1	The number of "Error Record"	8-bits hexadecimal coded ASCII	
2	The maximum number of "Error Record"	8-bits hexadecimal coded ASCII	Up to 20 for STP-iXA3306
3 to 22	Error Record 1 to Error Record 20	80-bits hexadecimal coded ASCII (See "Error Record Format")	*1

*1 The recent error has the smallest parameter number.

Error record format:

Time information of error history has two formats that depend on the pump model.

- Total running time of the STP pump and control unit
- Real time data by a built-in clock

Time information is identified with a time flag.

STP-iXA3306 Series Turbomolecular Pump

1. In case of time flag = 0

Parameter	Item	Data format	Remarks
a	Error Code	8-bits hexadecimal coded ASCII	*1
b	Time flag	8-bits hexadecimal coded ASCII	
c	Pump running time	32-bits hexadecimal coded ASCII	Unit: minute
d	Control unit running time	32-bits hexadecimal coded ASCII	Unit: minute

*1 Value corresponding to the error is transmitted (see Table 36, Table 37). When the number of errors being detected is under the maximum number, the value of parameter that is larger than the number of errors being detected is set to FFhex.

Example:

In case of Disturbance X_H detection at

Pump running time = 5,000 minutes, control unit running time = 6,000 minutes

Parameter	a		b		c								d								
ASCII	0	D	0	0	0	0	0	0	0	1	3	8	8	0	0	0	0	1	7	7	0
HEX	30	44	30	30	30	30	30	30	30	31	33	38	38	30	30	30	30	31	37	37	30

2. In case of time flag = 1

Parameter	Item	Data format	Remarks
a	Error Code	8-bits hexadecimal coded ASCII	*1
b	Time flag	8-bits hexadecimal coded ASCII	
c	Error detection time (Format : yymmddhhnn) yy: The last two digits of the year mm: Month dd: Day hh: Hour (24-hour display) nn: Minute	40-bits hexadecimal coded ASCII	*2
d	[System reservation]	24-bits hexadecimal coded ASCII	

*1 Value corresponding to the error is transmitted (see Table 36, Table 37). When the number of errors being detected is under the maximum number, the value of parameter that is larger than the number of errors being detected is set to FFhex.

*2 Each value of time is transmitted as BCD form character string.



STP-iXA3306 Series Turbomolecular Pump

Example:

In case of Disturbance X_H detection at September 13, 2007 12: 34

Parameter	a		b		c								d							
ASCII	0	D	0	1	0	7	0	9	1	3	1	2	3	4	*3	*3	*3	*3	*3	*3
HEX	30	44	30	31	30	37	30	39	31	33	31	32	33	34						

*3 System reservation

Example:

When 3 errors have been detected in the past;

- The number of "Error Record": $03_{hex} = 3$ errors
- The maximum number of "Error Record": $14_{hex} = 20$ errors
- Error Record 1: Error Code $0F_{hex} = 15 =$ Disturbance Xb
Time flag $01_{hex} =$ Detection time is built-in clock time
Error detection time $0709131234_{hex} =$ Sep. 13, 2007 at 12:34
- Error Record 2: Error Code $0D_{hex} = 13 =$ Disturbance Xh
Time flag $01_{hex} =$ Detection time is built-in clock time
Error detection time $0704300659_{hex} =$ Apr. 30, 2007 at 06:59
- Error Record 3: Error Code $12_{hex} = 18 =$ MOTOR Overheat
Time flag $01_{hex} =$ Detection time is built-in clock time
Error detection time $0612011508_{hex} =$ Dec. 1, 2006 at 15:08
- Error Record 4 to 20 No error recorded

Parameter	1		2	
ASCII	0	3	1	4
HEX	30	33	31	34

Parameter	3a		3b		3c								3d							
ASCII	0	F	0	0	0	7	0	9	1	3	1	2	3	4	*1	*1	*1	*1	*1	*1
HEX	30	46	30	30	30	37	30	39	31	33	31	32	33	34						

Parameter	4a		4b		4c								4d							
ASCII	0	D	0	0	0	7	0	4	3	0	0	6	5	9	*1	*1	*1	*1	*1	*1
HEX	30	44	30	30	30	37	30	34	33	30	30	36	35	39						

Parameter	5a		5b		5c								5d							
ASCII	0	F	0	0	0	6	1	2	0	1	1	5	0	8	*1	*1	*1	*1	*1	*1
HEX	30	46	30	30	30	36	31	32	30	31	31	35	30	38						



STP-iXA3306 Series Turbomolecular Pump

Parameter	6a		6b		6c										6d							
ASCII	F	F	0	0	0	0	0	0	0	0	0	0	0	0	0	0	*1	*1	*1	*1	*1	*1
HEX	46	46	30	30	30	30	30	30	30	30	30	30	30	30	30	30						

Parameter	7a		7b		[Omitted]										21d									
ASCII	F	F	0	0													0	0	*1	*1	*1	*1	*1	*1
HEX	46	46	30	30													30	30						

Parameter	22a		22b		22c										22d							
ASCII	F	F	0	0	0	0	0	0	0	0	0	0	0	0	0	0	*1	*1	*1	*1	*1	*1
HEX	46	46	30	30	30	30	30	30	30	30	30	30	30	30	30	30						

*1 System reservation

5.4.20 SetOptions

Function: Changes the setting value of optional function. The parameter n depends on the optional function.

Transmission frame:

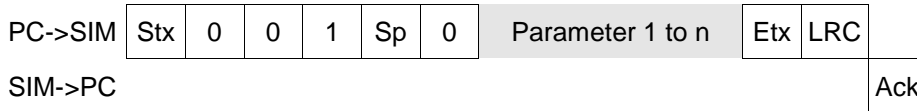

Parameter	Item	Data format	Remark
1	Optional function number	16-bits hexadecimal coded ASCII	see Table 42
2 to n	Function item		

Optional function number	Value	Total parameter n	Remark
Second speed option setting	0014	3	see 5.4.20.1
Second speed selection	0015	2	see 5.4.20.2

Table 42 - Option function number and parameter list

5.4.20.1 Second speed option setting

Settings for second speed can be changed.

CAUTION

There is an endurance limit of setting changes (no more than 24 times per day for about ten years). If this limit is exceeded, it not only may become impossible to change the setting but can also cause pump failure. Do not make setting changes in excess of this endurance limit.

Parameter	Item	Data format	Remark
1	Optional function number	16-bits hexadecimal coded ASCII	0014 hex
2	Second speed setting (Unit: Hz)	16-bits hexadecimal coded ASCII	*1
3	Second speed option setting	16-bits hexadecimal coded ASCII	0000 hex : DISABLE 00FF hex : ENABLE

*1 This value can be changed in the range from half of the rated rotational speed to the rated rotational speed. When the parameter value is larger than the rated rotational speed, it is automatically set to the rated rotational speed. When the parameter value is smaller than half of rated rotational speed, it is automatically set to half of rated rotational speed.

Example:

Second speed setting : 00E1hex = 225 Hz = 13500 rpm

Second speed option setting : 0000hex = DISABLE

Parameter	1				2				3			
ASCII	0	0	1	4	0	0	E	1	0	0	0	0
HEX	30	30	31	34	30	30	45	31	30	30	30	30

5.4.20.2 Second speed selection

The normal rating speed setting or second rating speed setting can be selected in the normal state.

When using this function, set the second speed option to the "ENABLE".

Parameter	Item	Data format	Remark
1	Optional function number	16-bits hexadecimal coded ASCII	0015 hex
2	Second speed selection	16-bits hexadecimal coded ASCII	0000 hex: Normal rating speed setting 0001 hex: Second rating speed setting

Example:

Second speed selection : 0000hex = Normal rating speed setting

Parameter	1				2			
ASCII	0	0	1	5	0	0	0	0
HEX	30	30	31	35	30	30	30	30

5.4.21 ReadOptions

Function: Reads the setting value of optional function. The parameter n depends on the optional function.

Transmission frame:

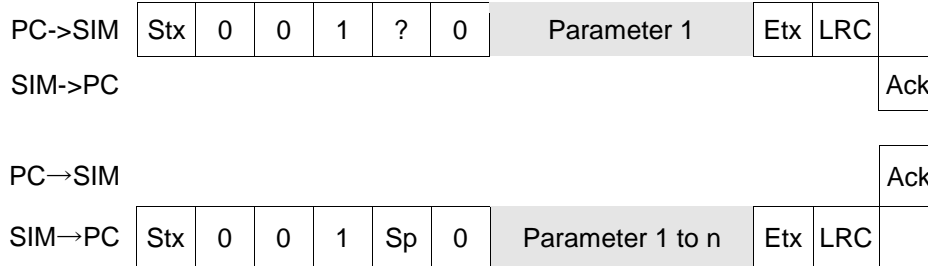

Parameter	Item	Data format	Remark
1	Optional function number (receive/return)	16-bits hexadecimal coded ASCII	see Table 43
2 to n	Function items (return)		

Optional function number	Value	Total response parameter n	Remark
Second speed option setting	0014	4	see 5.4.21.1
Second speed selection	0015	2	see 5.4.21.2

Table 43 - Option function number and parameter list

5.4.21.1 Second speed function setting

Settings for second speed can be changed.

Parameter	Item	Data format	Remark
1	Optional function number	16-bits hexadecimal coded ASCII	0014 hex
2	Second speed setting (Unit: Hz)	16-bits hexadecimal coded ASCII	
3	Second speed option setting	16-bits hexadecimal coded ASCII	0000 hex : DISABLE 00FF hex : ENABLE
4	Selected speed value (Unit: Hz)	16-bits hexadecimal coded ASCII	

STP-iXA3306 Series Turbomolecular Pump

Example:

- Second speed setting : 00E1_{hex} = 225 Hz = 13500 rpm
- Second speed option setting : 0000_{hex} = DISABLE
- Selected speed value : 01C2_{hex} = 450 Hz = 27000 rpm (Normal rating speed setting)

Parameter	1				2				3				4			
ASCII	0	0	1	4	0	0	E	1	0	0	0	0	0	1	C	2
HEX	30	30	31	34	30	30	45	31	30	30	30	30	30	31	43	32

5.4.21.2 Second speed select

The speed setting set as rotational speed in the normal state can be read.

Parameter	Item	Data format	Remark
1	Option function number	16-bits hexadecimal coded ASCII	0015 hex
2	Second speed selection	16-bits hexadecimal coded ASCII	0000 hex: Normal rating speed setting 0001 hex: Second rating speed setting

Example:

- Second speed selection : 0000_{hex} = Normal rating speed setting

Parameter	1				2			
ASCII	0	0	1	5	0	0	0	0
HEX	30	30	31	35	30	30	30	30



STP-iXA3306 Series Turbomolecular Pump

This page intentionally blank.

6 STP-LINK and DISPLAY UNIT

The STP-Link (optional accessory) and the display unit iDT-001 (optional accessory) are available with the STP pump.

6.1 STP-Link

The "STP-Link" is a Windows application for operating the STP pump, confirming the pump status or setting various settings. Table 44 shows the principal functions.

See the Instruction Manual of the "STP-Link" for the detailed specification and operating method.

Item	Functions
Operating function	Start, stop and failure reset operation of STP pump
Confirmation function	Operational state of STP pump
	Software version
	Serial number
	STP pump model
	Operation hours
	Number of starts
	Bearing damage integrated value
	Error history
Option setting function	Remote operation mode setting
	Serial port setting
	Rotational speed setting
	TMS function setting
	Warning function setting

Table 44 - Functions of STP-Link

6.2 Display unit

The "display unit" operates the STP pump, confirms the pump status or sets various settings. The display unit iDT-001 is equipped with an LCD and flat panel switches.

See the Instruction Manual of the "Display unit iDT-001" for the detailed specification and operating methods.

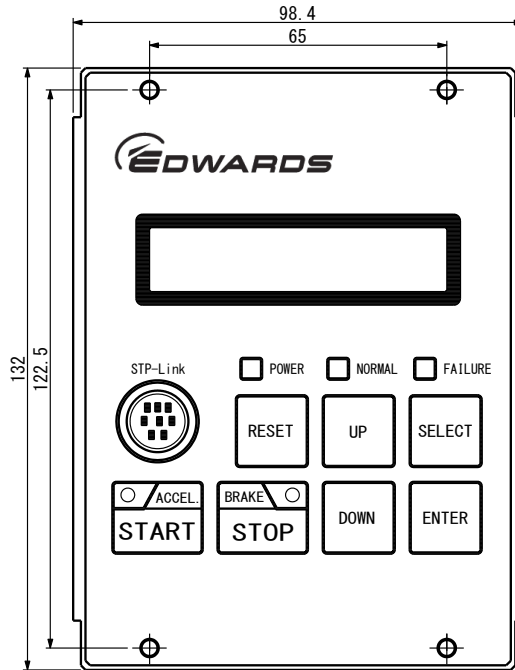

Figure 56 - Display unit iDT-001

7 SAFETY FUNCTIONS

The STP pump is provided with safety functions for various abnormalities/errors. When two or more warnings are detected simultaneously, a high-priority warning is indicated. Also, the warning signal is output from the "X2 REMOTE" connector. If an abnormality/error is found when using the STP pump, check it and take measures in accordance with the following procedures. If you cannot trace it or if the STP pump does not function normally after the troubleshooting, contact Service office.

7.1 Safety functions

Note: The flashing pattern of the "FAILURE" LED (red) indicates the type of failure. Refer to Section 7.6, "Troubleshooting" for details.

7.1.1 Power Failure

When the power voltage drops below 160 V due to a power failure or another fault, the normal operation of the magnetic bearing is maintained at the high rotational speed using the regenerative energy of the rotating rotor (backup operation during a power failure).

The lowest rotational speed to which the magnetic bearing can operate at a power failure is called a backup rotational speed.

1. When the rotational speed is approx. 5,000 rpm or more at a power failure:

The STP pump detects any power failure of 2 seconds or more and decelerates. At this time, the "POWER" LED extinguishes and the "FAILURE" LED (red) illuminates. Also, POWER OUT pins (9)–(28) is opened, and a failure signal is output from FAILURE OUT pins (14)–(33) and (15)–(33) of the "X2 REMOTE" connector.

When the rotational speed goes down to approx. 5,000 rpm, the rotor lands on the touch down bearing and stops. All LCDs extinguish.

The STP pump does not detect a power failure of less than 2 seconds and the STP pump will continue to rotate.

2. When the rotational speed is less than approx. 5,000 rpm at a power failure:

The STP pump does not detect the power failure. The rotor lands on the touch down bearing and stops.

STP-iXA3306 Series Turbomolecular Pump

Table 45 shows the states of LED output and the "X2 REMOTE" output signals at a power failure.

Rotational speed	Duration of power failure	LEDs		REMOTE output signal (REMOTE X2)		
		POWER LED	FAILURE LED	POWER	ALARM	
					N.O.	N.C.
5,000 rpm or more	Approx. 2 sec. or longer	Extinguish	Illuminate	Open	Close	Open
	Shorter than approx. 2 sec.	Continues as before				
Less than 5,000 rpm		Extinguish	Extinguish	Open	Open	Close

Table 45 - States of LEDs and X2 REMOTE output signals at power failure

7.1.2 Operation after a power recovery

1. The STP pump continues decelerating, and power failure detection is reset automatically.

At this time, the "POWER" LED illuminates and the "FAILURE" LED extinguishes. Also, POWER OUT pins (9)-(28) is closed, and a failure signal is reset between FAILURE OUT pins (14)-(33) and (15)-(33) of the "X2 REMOTE" connector.

2. When the START signal is input after a power recovery, the STP pump reaccelerates even while it is in BRAKE state.

When the START signal is input after a power recovery, the STP pump reaccelerates even while it is in BRAKE state.

However, the control unit may detect excessive vibration when power is recovered after the rotor lands on the touch down bearing (see 7.1.4). In this case, the STP pump once stops and cannot reaccelerate until the RESET operation completed (see Section 4.7.2).

Note: It is recommended to establish a procedure so that the power can be supplied to the STP pump immediately after a power recovery.

7.1.3 Abnormal state of magnetic bearing (Disturbance)

CAUTION

When an abnormality/error occurs in the magnetic bearing, check the STP pump.
If "FAILURE" cannot be released after reset operation, contact Service office.

When the magnetic bearing does not function normally due to a breakage of the STP connection cable, disconnection of connectors or any abnormality/error of the STP control circuit, the rotor lands on the touch down bearing and stops. The "FAILURE" LED (red) flashes, and a failure signal is output from the "X2 REMOTE" connector.

7.1.4 Excessive vibration (Disturbance)

When serious vibration or mechanical shock causes the rotor to come in contact with the touch down bearing (due to external vibration/impact, intrusion of atmosphere, foreign matter into the STP pump, or rotor imbalance), and the state lasts for a certain period of time, the STP pump decelerates and stops.

The "FAILURE" LED (red) flashes, and a failure signal is output from the "X2 REMOTE" connector.

Note: When the rotor contacts the touch down bearing, contact noise and rotational noise of the touch down bearing are generated from the STP pump.

7.1.5 Motor driver overload (DRV Overload)

When the STP pump does not attain the rated speed within approx. 30 minutes after starting or when the ACCELERATION state remains unchanged during operation for approx. 30 minutes, the STP pump decelerates and stops.

The "FAILURE" LED (red) flashes, and a failure signal is output from the "X2 REMOTE" connector.

7.1.6 Overheating inside the STP pump (MOTOR Overheat)

When the temperature of the motor inside the STP pump is overheated due to an overload, the STP pump decelerates and stops.

The "FAILURE" LED (red) flashes, and a failure signal is output from the "X2 REMOTE" connector.

7.1.7 Overheating inside the control unit (CNT Overheat)

When the temperature inside the control unit rises due to abnormal cooling water flow rate or water temperature, external heat source, failure of an air-cooling fan, or other event, the STP pump decelerates and stops.

The "FAILURE" LED (red) flashes, and a failure signal is output from the "X2 REMOTE" connector.

7.1.8 Overspeed

When the rotational speed of the STP pump exceeds 29,000 rpm due to a failure in the motor driver, the STP pump changes into free-running and stops.

The "FAILURE" LED (red) illuminates, and a failure signal is output from the "X2 REMOTE" connector.

7.1.9 Abnormality/Error in the TMS unit (for use with the TMS unit)

If the temperature of the STP pump base unit is higher than the setting value by 10 °C (18 °F) or more due to the occurrence of an abnormality/error in the TMS heater or other fault, the "FAILURE" LED illuminates and a failure signal is output from the "X2 REMOTE" connector. The heater is switched OFF and the cooling water unit is operated. The STP pump decelerates and stops. Continue to operate the cooling water unit until the temperature of the pump base is reduced at the setting value after the pump stops.

If the temperature of the STP pump base unit is lower than the setting value by 10 °C (18 °F) or more due to the occurrence of an abnormality/error in the TMS heater or other fault, the "FAILURE" LED illuminates and a failure signal is output from the "X2 REMOTE" connector. The heater and the cooling water valve are switched OFF and the STP pump decelerates and stops.

Note: "TMS Lower Temp" is not detected for a certain time when the STP pump starts.

When an abnormality/error occurs in the TMS connection cable, the STP pump decelerates and stops. The heater and the cooling water unit are switched OFF. The "FAILURE" LED illuminates and a failure signal is output from the "X2 REMOTE" connector.

7.2 "WARNING" function

7.2.1 "WARNING" function

The STP pump is provided with a WARNING function when an overhaul is needed following a self-test as shown in Table 46.

The type of warning is indicated by flashing pattern of the "FAILURE" LED (orange).

When two or more warnings are detected simultaneously, a high-priority warning is indicated. Also, the warning signal is output from the "X2 REMOTE" connector.

The serial communication, the STP-Link (optional accessory), or the display unit iDT-001 (optional accessory) can confirm the error message, and change the settings.

Refer to Section 5, "Serial Communication Protocol", the STP-Link or the display unit iDT-001 Instruction Manual of the optional accessories for details.

No	Warning	"FAILURE" LED indication	Priority
1	First Damage Limit Second Damage Limit (Touch down bearing warning function)	3 flashes in orange	High  Low
2	Pump Run Time Over (Pump runtime warning function)	2 flashes in orange	
3	Pump Overload (Pump overload warning function)		
4	Imbalance (Excessive imbalance warning function)	1 flash in orange	Low

Table 46 - WARNING function

STP-iXA3306 Series Turbomolecular Pump

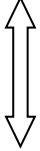
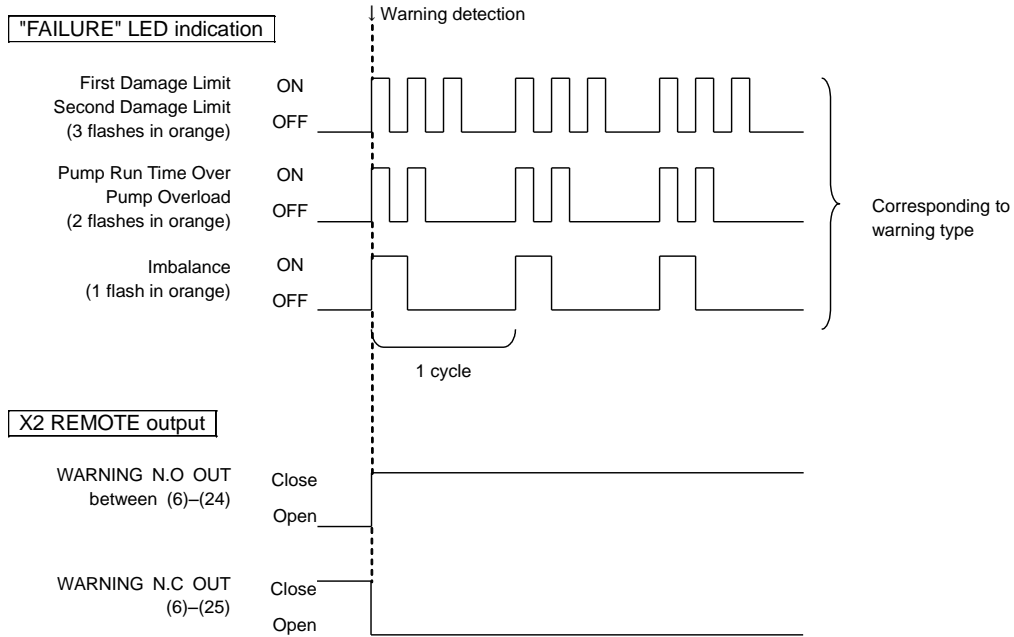

Figure 57 - WARNING output

Note: The WARNING detection cannot be reset by the "RESET" operation. See Section 7.4, "WARNING function setting" for the releasing the WARNING detection. The STP pump can operate even when the WARNING is detected. Overhaul the STP pump when WARNING detection is indicated.

7.3 Contents of WARNING function

7.3.1 First Damage limit

Impact of the STP pump rotor onto the touch-down bearing, such as by an unexpected in-rush of air from outside or in the event of power failure, can damage the touch-down bearings. The STP pump monitors these impacts and assigns damage points to the event of "Disturbance" or "Power Failure". When the accumulated damage point attains certain points, the "First Damage Limit" is detected.

"First Damage Limit" warning can be released by setting the warning function to disable after it is detected. The accumulated damage points can be confirmed and the setting can be changed via serial communication, the STP-Link (optional accessory) or the display unit iDT-001 (optional accessory).

7.3.2 Second Damage Limit

"Second Damage Limit" is detected when continuing to operate the STP pump after "First Damage Limit" is detected and the accumulation of the damage point attains the setting value by further "Disturbance" and "Power Failure".

"Second Damage Limit" detects the warning and a failure at the same time.

Overhaul the STP pump because the STP pump cannot perform the rotational operation when "Second Damage Limit" is displayed.

When operating the STP pump is needed after "Second Damage Limit" is displayed, disable the "Second Damage Limit". The rotating operation can be performed even though the "WARNING" is detected.

The setting can be changed via serial communication, the STP-Link (optional accessory) or the display unit iDT-001 (optional accessory).

7.3.3 Pump run time over

There is a run-time counter that tracks the total running hours of the pump. When the run-time counter attains the setting value, the "Pump Run Time Over" is detected. When deposit accumulates inside the STP pump, this function can be used to consider the time of the overhaul.

The setting value is user-definable.

Confirmation of the total running hours of the pump and change of the setting value can be performed via serial communication, the STP-Link (optional accessory) or the display unit iDT-001 (optional accessory).

7.3.4 Pump Overload

"Pump Overload" is displayed when the state that the motor current exceeding the setting value continues during the fixed time or the state that the STP pump rotational speed drops below the setting value continues during the fixed time. However, the motor current and the rotational speed are monitored only in the NORMAL state.

When the deposit accumulates in the STP pump, the load in NORMAL state may gradually grow with the operating time. Considering the time of the overhaul, this "WARNING" function can be used.

The current setting value and rotational speed setting value are user-definable. "Pump Overload" warning can be released by setting the warning function to disable after it is detected.

The setting can be changed via serial communication, the STP-Link (optional accessory) or the display unit iDT-001 (optional accessory).

7.3.5 Imbalance

The STP pump continuously monitors its rotor balance. The "Imbalance" is detected when imbalance of the synchronized rotor with the rotational speed exceeds the setting value.

When the deposit accumulates in the STP pump, with the increase of the STP pump operation hours, the rotor balance is lost and the imbalance increases gradually. An increase in the amount of deposit may lead to a malfunction of the STP pump. Perform the overhaul ahead usual case.

The setting value of the imbalance is fixed, and the user cannot set it.

Set the "WARNING" function of the Enable/Disable to disable to release the "Imbalance X_H", "Imbalance X_B" or "Imbalance Z". The setting can be changed via serial communication, the STP-Link (optional accessory) or the display unit iDT-001 (optional accessory).

7.4 WARNING function setting

The WARNING functions can be set to Enable or Disable. Set to "ENABLE" when using the WARNING function. Set to "DISABLE" to release each WARNING function after the WARNING is detected.

A setting value of the "Pump Run Time Over" and "Pump Overload" are adjustable. The WARNING detection can be released by setting the value larger than pump running hours after "Pump Run Time Over" is detected. Also, the WARNING detection can be released by powering off the pump after "Pump Overload" is detected.

See Table 47 and Table 48 for the default setting. The setting can be changed via serial communication, the STP-Link (optional accessory) or the display unit iDT-001 (optional accessory).

WARNING function	Default setting	User setting	User setting change (threshold)
Second Damage Limit (Failure detection)	Enable	Enable	Disable
Second Damage Limit (Warning detection)	Enable	Disable	Disable
First Damage Limit	Enable	Enable	Disable
Pump Run Time Over	Disable	Enable	Enable
Pump Overload	Disable	Enable	Enable
Imbalance	Enable	Enable	Disable

Table 47 - Default setting of WARNING function

WARNING function	Factory setting (threshold)		Variable range	User setting change (threshold)
Pump Run Time Over	0 hour		0 to 100,000 hours	It can be set in units of 100 hour. 0 is not counted.
Pump Overload	Motor current	100.0 %	0 to 100.0 %	The ratio (%) to the rated current value. Smaller value has high possibility to get "WARNING".
	Rotational speed	0.0 %	0 to 100.0 %	The rate (%) to the rated speed value. Larger value has high possibility to get "WARNING".

Table 48 - Factory Setting and Variable Range

Note: Refer to Section 5, "Serial Communication Protocol", STP-Link, or the display unit iDT-001 Instruction Manuals for the setting methods.

7.5 Troubleshooting immediately after failure occurs

The STP pump is provided with safety functions for various abnormalities/errors. A safety function operates when an abnormality/error occurs. The "FAILURE" LED illuminates or flashes. Also, the failure signal is output from the "X2 REMOTE" connector. If an abnormality/error is found when using the STP pump, check it and take measures in accordance with the following procedures. If you cannot trace the cause of the error or if the STP pump does not function normally after troubleshooting, fill in the necessary information in the "Return Declaration" form and fax it to the Service office.

7.5.1 After power failure

It is recommended to establish a procedure so that the power can be supplied to the STP pump immediately after a power recovery.

7.5.2 After other abnormality/error

	WARNING
	When disconnecting cables from the STP pump and/or the cables to perform troubleshooting and take the necessary action, confirm that the STP pump has stopped, power off the primary power (switch the MAIN POWER to "OFF") and isolate (Lockout/Tagout) the electrical energy source water and gas and other energy sources on the vacuum equipment. Failure to do so may result in the inadvertent rotation of the STP pump which may result in an accident, an electric shock or damage to equipment. Moreover, an accident caused by water leaks or gas leak may occur.

CAUTION
If the RESET operation does not extinguish the "FAILURE" LED, confirm that the STP pump has stopped, turn OFF the primary power (Switch the switch "OFF"), then turn ON the primary power (Switch the switch "ON") again.

1. After confirming the "ROTATION" LED has extinguished and the STP pump has stopped, remove the probable cause of the abnormality.
When the "FAILURE" LED illuminates or flashes, follow the recommended actions given in Table 50, "Error List".
2. Perform the RESET operation to extinguish the "FAILURE" LED.
3. Perform the START operation. Check if the STP pump operates correctly.

7.6 Troubleshooting

7.6.1 Indication of "FAILURE" LED (red)

The flashing pattern of the "FAILURE" LED (red) differs depending on the type of abnormality/error. When two or more failures are detected simultaneously, a high-priority failure is indicated. Also, the failure signal is output from the "X2 REMOTE" connector. If an abnormality/error is found, take measures in accordance with Table 50 to Table 55.

No	Failure	"FAILURE" LED indication	Priority
1	Power Failure Overspeed, and other	Steady red	High Low
2	MOTOR Overheat CNT Overheat	3 flashes in red	
3	DRV Overload	2 flashes in red	
4	Disturbance	1 flash in red	

Table 49 - Priority of failure signal

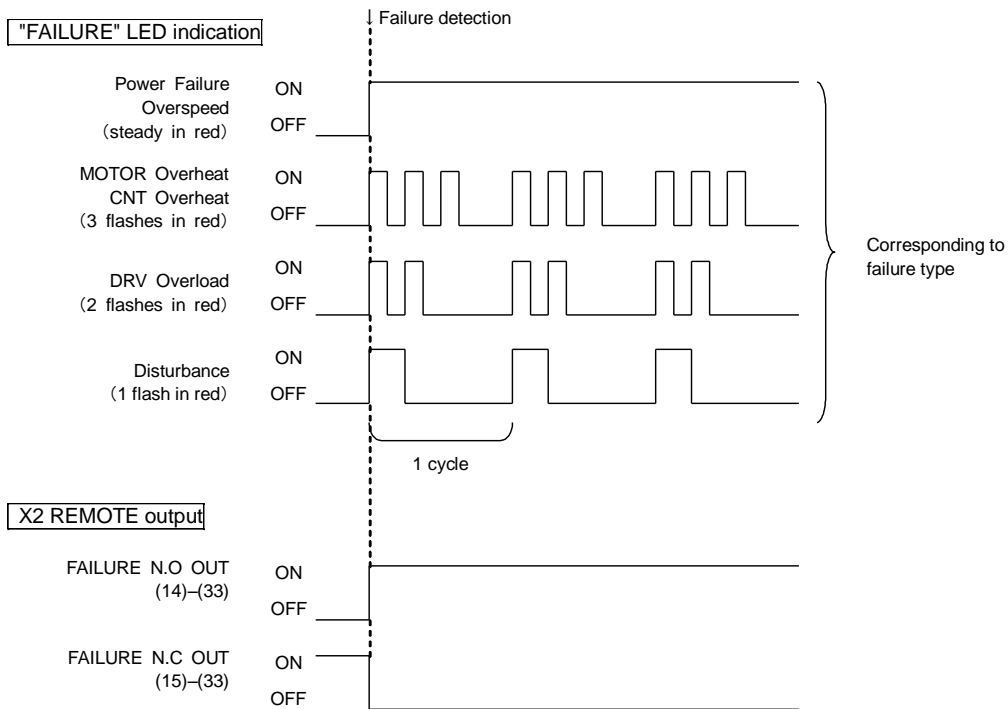

Figure 58 - Failure output

Note: The STP-Link (optional accessory) and the display unit (optional accessory) display an error as a message. Also, the errors being detected can be read via serial communication.

"FAILURE" LED	(Error message)	Pump operation	Occurrence condition	Probable causes	Countermeasures	Referred Section
1 flash in red	Disturbance X_H Disturbance Y_H stop Disturbance X_B Disturbance Y_B Disturbance Z	Decelerate and stop	Excessive imbalance	Excessive vibration applied externally to the STP pump: 1. External vibration/impact. 2. Atmospheric air flows into the STP pump. 3. Foreign materials fall into the STP pump. 4. Sudden pressure change at start of roughing	1. Remove external vibration so as not to transmit it to the STP pump. 2. Check the vacuum piping. 3. Install the STP pump in a way that no foreign materials fall into the STP pump. 4. Perform roughing vacuum through bypass root. Contact Service office.	3.4.4 3.9 3.4.1
2 flashes in red	DRV Overload	Decelerate and stop	Acceleration state continues for approx. 30 minutes	Abnormal magnetic bearing: 1. Control circuit error. 2. Disconnection of the internal wiring. 1. High pressure at the inlet port. 2. High pressure at the outlet port. 3. Leakage of the piping system. 4. Failure of the backing-pump.	1. Use the maximum working pressure or less. 2. Use the allowable backing pressure or less. 3. Check the vacuum piping system for leakage. 4. Check the backing-pump for its capacity and START state. (use a backing-pump with the recommended capacity or more)	2.1 2.1 4.4.2 2.1

Table 50 - Error List

STP-iXA3306 Series Turbomolecular Pump

"FAILURE" LED	(Error message)	Pump operation	Occurrence condition	Probable causes	Countermeasures	Referred Section
3 flashes in red	MOTOR Overheat	Decelerate and stop	Overheating inside the STP pump	<ol style="list-style-type: none"> Overheating during baking. Insufficient cooling. Leakage of the vacuum piping system. Repetitive start/stop operations. Failure of the air-cooling fan. 	<ol style="list-style-type: none"> Set the temperature of the baking heater to 120 °C or less. At the time of baking or gas pumping, always cool the STP pump. Check the piping system for leakage. Repetitious start/stop operations may cause the STP pump to overheat. Replace the air-cooling fan. Contact Service office. 	4.1 4.1 4.4.2 4.4
	CNT Overheat 1, 2, 3	Decelerate and stop	Overheating inside the control unit	<ol style="list-style-type: none"> High ambient temperature. Insufficient cooling of the control unit. Failure of the air-cooling fan. 	<ol style="list-style-type: none"> Set the ambient temperature to 40 °C or less. Set the cooling water flow rate at 3 L/min and cooling water temperature between 15 to 35 °C. Replace the air-cooling fan. Contact Service office. 	3.1.1 2.3
Steady red	Aberrant Accel	Free run ^{*1}	Rotational speed increases in brake or Levitation state	Atmospheric air flows the STP pump.	<ol style="list-style-type: none"> Check the vacuum piping system for leakage. Check the exhaust sequence. Turn "OFF" the switch to stop the pump, and then turn "ON" the switch again to recover. 	4.10.1

^{*1} The driver output stops and the rotor continue rotating by inertia. It may take several hours to stop. To stop the STP pump quickly, close the vacuum valve at the outlet port flange and introduce gas from the purge port into the STP pump.

Table 51 - Error List (continued)

"FAILURE" LED	(Error message)	Pump operation	Occurrence condition	Probable causes	Countermeasures	Referred Section
Steady red	Aberrant Brake	Free run, or decelerate and stop	The rotation does not stop after 30 min. into brake state	Failure of the control unit.	Contact Service office.	
	Acc Malfunction	Stop	Accelerate up to 2000 rpm or less	1. Malfunction by external noise. 2. Failure of the control unit.	1. Perform re-start operation after resetting. 2. Contact Service office.	
	AMB Com. Failure	Decelerate and stop	Communication failure in the control unit	Failure of the control unit.	Contact Service office.	
	Driver Failure	Decelerate and stop	Communication failure with motor control board	1. Malfunction by external noise. 2. Failure of the control unit.	1. Perform re-start operation after resetting. 2. Contact Service office.	
	DRV Com. Failure	Decelerate and stop	Communication failure with motor control board	Failure of the control unit.	Contact Service office.	
	DRV Overcurrent	Free run ^{*1}	Motor driver over current	1. Short-circuit or ground fault in the motor winding. 2. Failure of the control unit.	Contact Service office.	
	DRV Overvoltage	Free run ^{*1}	Motor driver over voltage	Failure of the control unit.	Contact Service office.	
	FAN Trouble	Decelerate and stop	Cooling fan come to a stop	1. Wear-out of the cooling water bearing. 2. Failure of the control unit.	Contact Service office.	
	Inordint Current	Touch down	The Excessive magnetic bearing output stops and the rotor is descended on the touch down bearing.	1. Failure of the STP pump. 2. Failure of the control unit.	Contact Service office.	

^{*1} The driver output stops and the rotor continue rotating by inertia. It may take several hours to stop.
To stop the STP pump quickly, close the vacuum valve at the outlet port flange and introduce gas from the purge port into the STP pump.

Table 52 - Error List (continued)

"FAILURE" LED	(Error message)	Pump operation	Occurrence condition	Probable causes	Countermeasures	Referred Section
Steady red	M_Temp Lost	Decelerate and stop	Abnormal motor temperature detection	Disconnection of the motor temperature sensor.	Contact Service office.	
	Overspeed 1, 2, 3, 4	Decelerate and stop	Rotational speed exceeds rated speed	Failure of the control unit.	Contact Service office.	
	Power Failure	Decelerate and stop	Insufficient power supply	1. Power failure.	1. Check whether or not a power failure has occurred.	7.1.1
				2. Incorrect connection of the power cable. 3. Failure of the power cable. 4. Failure of the power supply voltage.	2. Connect the power cable correctly. 3. Replace the power cable. 4. Set the rated voltage \pm 10%.	3.8.2 3.8.2 3.8.1
			Overheat inside the control unit.	1. Insufficient cooling of the control unit. 2. Failure of the control unit.	1. Check the volume of water and water temperature with water cooling unit. In order to recover, turn off the power (switch "OFF"), and then switch "ON" after sufficient cooling of the control unit (isolate input power supply 3 minutes or more) 2. Contact Service office.	3.5

Table 53 - Error List (continued)

"FAILURE" LED	(Error message)	Pump operation	Occurrence condition	Probable causes	Countermeasures	Referred Section
Steady red	Power Supply Fail	Decelerate and stop	Power supply circuit failure in control unit	Failure of the control unit.	Contact Service office.	
	Ram Error	Decelerate and stop	Failure of RAM check in MPU	Failure of the control unit.	Contact Service office.	
	Second Damage Limit	Decelerate and stop	Damage point exceeds setting value	Frequency of "Disturbance" or "Power Failure" error.	Overhaul is needed. Contact Service office.	
	Serial Com. Fail	Decelerate and stop	Communication failure of the input operation port during acceleration and normal operation	1. Insufficient user application setting. 2. Disconnection or break of the communication cable. 3. Failure of the control unit.	1. Send a communication command periodically at intervals of less than setting value. 2. Check the communication cable. 3. Contact Service office.	5.2.5
	Speed Pulse Lost	Decelerate and stop	Abnormal rotational speed detection	Failure of the control unit.	Contact Service office.	
	TMS Higher Temp	Decelerate and stop	TMS temperature control error (when the TMS unit detection temperature becomes higher than the setting value by 10°C (+18 °F) or more.	1. Cooling failure of TMS unit. 2. Failure of TMS unit.	1. Connect the electromagnetic cooling water valve correctly. Check the volume of water and water temperature. 2. Contact Service office.	3.11

Table 54 - Error List (continued)

"FAILURE" LED	(Error message)	Pump operation	Occurrence condition	Probable causes	Countermeasures	Referred Section
Steady red	TMS Lower Temp	Decelerate and stop	TMS temperature control error (when the TMS unit detection temperature becomes lower than the setting value by 10 °C (-18 °F) or more. Error is not detected for a certain time after the STP pump starts.	<ol style="list-style-type: none"> 1. Failure of the TMS heater. 2. Failure of the TMS unit. 	<ol style="list-style-type: none"> 1. Contact Service office. 2. Contact Service office. 	
	TMS Sensor Lost	Decelerate and stop	TMS sensor is not connected when the state "TMS Option" is "ENABLE".	<ol style="list-style-type: none"> 1. Disconnection of the TMS sensor. 2. Disconnection of the external TMS connection cable. 3. Failure of the external TMS3 connection cable. 4. Incorrect setting of the TMS function. 	<ol style="list-style-type: none"> 1. Contact Service office. 2. Connect the cable securely. 3. Contact Service office. 4. When the TMS function is not in use, set the "TMS Option" to "DISABLE" with display unit iDT-001 or STP-Link. 	

Table 55 - Error List (continued)

7.6.2 Indication of "FAILURE" LED (green)

If an abnormality/error is detected by self test during the power ON operation, "FAILURE" LED flashes green. This is the indication of STP pump or control unit failure. Contact Service Office.

7.6.3 No Indication of the "FAILURE" LED

No.	Symptom	Probable cause	Countermeasures	Referred Section
1	The "POWER" LED does not illuminate.	Incorrect connection of power cable	Connect the power cable correctly.	
		Abnormal power voltage	Set the input voltage to the rated voltage $\pm 10\%$.	
		Power failure	Check whether or not a power failure has occurred.	
2	The "ROTATION" LED does not flash after performing the start operation.	Failure of the "Input Operation Port" setting.	Set the input operation port correctly.	
		Rotation INHIBIT signal input pins (X2 REMOTE (1)-(5)) are opened.	When not using this function, short the circuits between (1)-(5), or open the circuits between (1)-(2) of the "X2 REMOTE" connector.	
3	Rotation INHIBIT signal does not function correctly.	Rotation INHIBIT enable signal input pins are opened.	Short the circuits between (1)-(2) of the "X2 REMOTE" connector.	
4	Insufficient ultimate pressure.	Failure of the backing-pump.	Check the capacity and starting state (use a backing-pump having more capacity than we specified).	
		Leakage of the piping system.	Check the piping system for leakage.	
		Residual molecules.	If the main composition is H ₂ or H ₂ O, perform baking; if it is other gases, clean the inside of the vacuum equipment (If gases remain inside the STP pump, contact Service office when it is needed to be cleaned).	
5	Abnormal noise is generated while the pump is rotating	External vibration or impact	Remove external vibration so as not to transmit it to the STP pump.	

Table 56 - Troubleshooting with no indication of the "FAILURE" LED

8 MAINTENANCE AND INSPECTION

Installation, operation and maintenance must only be executed by personnel who read through this Manual carefully and have the specific skills to perform installation, operation and maintenance of the STP pump. Confirm that no power is applied to the STP pump (refer to SEMI S2 Section 13.2 - type 1).

8.1 Maintenance and inspection

	<p style="text-align: center;">WARNING</p> <p>When performing maintenance and inspections of the STP pump, exhaust gases inside the STP pump thoroughly. Residual gases may cause an accident when removing the STP pump. To prevent an accident, confirm the characteristics of gases to be used, referring to the Material Safety Data Sheet (MSDS) you obtain from the gas supplier. Wear personal protective clothing if necessary.</p>
---	--

	<p style="text-align: center;">WARNING</p> <p>Before carrying out any maintenance or inspections on the STP pump, confirm that the STP pump has stopped, power off the primary power (switch the MAIN POWER to "OFF") and isolate (Lockout/Tagout) the electrical energy source, water and gas, and other energy sources on the vacuum equipment. Failure to do so may result in the inadvertent rotation of the STP pump which may result in an accident, an electric shock or damage to equipment. Moreover, an accident caused by water leaks or gas leak may occur.</p>
---	--

	<p style="text-align: center;">WARNING</p> <p>The wipes used for clean and decontamination might become hazardous waste depending upon the solvent (alcohol). Dispose of the contaminated wipes appropriately according to the regulations of each national and/or local government.</p>
---	---

<p style="text-align: center;">CAUTION</p> <p>DO NOT touch any place other those specified when performing maintenance or inspecting the pump and NEVER open any panel because it could cause shock, malfunction, or short circuit.</p>	
--	--

Power OFF the peripheral equipments before performing maintenance and inspections.

Only Edwards will replace the maintenance parts, and will execute repair and overhaul. Contact Service office.

8.2 Cleaning

The method for cleaning the STP pump is as follows:

- Clean the outside of the STP pump with proper solvent as required. An alcohol solvent can be used.
- Clean off with a pure gas when dust has accumulated in the connector.
- Clean the outside of the control unit with a dry wipe as required.
- When dust has accumulated in the ventilation port, wipe off or vacuum it with the cleaner. In this case, dust must not enter in the control unit.
- If the label of the STP pump has been damaged, contact Edwards.

The decontamination (overhaul) in the STP pump is executed in Service office. When an overhaul is needed, contact Service office.

8.3 Inspecting the deposit

CAUTION

Leaving the STP pump without removing the deposit may cause the STP pump to be corroded beyond repair.

Deposit may have accumulated inside the STP pump depending upon the type of the vacuum equipment installed in the STP pump. An increase in the amount of deposit may lead to a malfunction of the STP pump.

Therefore, perform regular maintenance (once every three to six months as a target).

Inspect the inside of the outlet port for adhesion of deposit while watching the outlet port. If deposit has accumulated to some extent, an overhaul (cleaning) is required. Contact Service office.

Note: The costs of troubleshooting problems resulting from deposit will be at your own charge even during the warranty period.

If a problem resulting from deposit occurs inside the STP pump, hermetically seal the inlet port, outlet port, purge port, leak port flanges, ventilation port of the control unit, and immediately return them to Service office.

For the transport method, see Section 8.5, "Transporting for repair or overhaul".

Contact with the atmosphere may cause a reaction of the deposit. DO NOT open the STP pump to the atmosphere.

Edwards can supply a Temperature Management System (TMS) unit which will keep the temperature high inside the STP pump and prevent the accumulation of deposit. For details, contact Edwards.

8.4 Maintenance

8.4.1 Recommended overhaul intervals

Regular overhaul (the cost of overhaul will be at your own charge) is required for safety and proper use of STP pump.

The recommended intervals for different process applications are tabulated below:

Process		Intervals	Remarks
Etching *1	Metal etch process (deposition)	1 year	Processes resulting in large amount of deposits in the pump will require more frequent service (includes non-etching process).
	Other etch process	2 years	
Other semiconductor process		2 years	
Clean application		5 years	No gases used (only vacuum pumping)
Other use		2 years	Dependent on application, contact Edwards.

*1 "Etching" includes semiconductor etching and LCD etching.

Note: When "First Damage Limit" warning or "Second Damage Limit" warning is detected, it is essential to have the touch down bearings replaced regardless of the recommended overhaul intervals. Warning detection is indicated by flashing of "FAILURE" LED (3 flashes in orange), a message on the display unit iDT-001 (optional accessory) or the STP-Link (optional accessory).

8.4.2 Standard replacement parts

When overhauling pumps, upper and lower touch down bearing, O-rings, dehumidifying agent (IP54 specification only) will be replaced as standard replacement parts.

STP-iXA3306 Series Turbomolecular Pump

8.4.3 Recommended maintenance intervals for main parts

Internal components of the STP pump will be damaged from gas load, heat, and corrosion when used long-term. Deterioration or abrasion of the internal parts of the STP pump will cause unexpected failures. When overhauling the STP pump, replacement of main parts are recommended. Refer to the following list as recommended maintenance intervals for main parts.

Part name		Recommended maintenance intervals ^{*1}	
		Corrosive gas	Inert gas or vacuum pumping only
Rotor blades		3 years	5 years
Rotor shaft		3 years	5 years
Motor, sensor, electromagnet, connector		5 years	7 years
Air-cooling fan		5 years	
PCBA in the control unit		7 years	
Accessories	TMS valve	3 years	
	TMS heater	3 years	
	Connection cable	5 years	

*1: Maintenance intervals of any parts may be shortened depending on the condition of use.

The costs of replacing parts that need to be replaced when deterioration or abrasion is observed will be at the customers charge, even though a period is not exceeding the recommended maintenance intervals.

When overhaul of the STP pump is needed, contact Service office.

8.5 Transporting for repair or overhaul

	<p>WARNING</p> <p>To prevent an accident, confirm the characteristics of gases to be used, referring to the Material Safety Data Sheet (MSDS) you obtain from the gas supplier. Wear personal protective clothing if necessary.</p>
--	--

	<p>WARNING</p> <p>When returning the STP pump which has used any kind of gases to Service office, ensure the "Return Declaration" form has been completed by filling, in the appropriate space, the type of gas(s) used and the precautions taken.</p>
--	---

	<p>WARNING</p> <p>To prevent an accident during transportation follow the instructions of the "Return Procedure".</p>
--	--

<p>CAUTION</p> <p>When returning the STP pump to Edwards, be sure to pack it well to prevent external damage. If the "Return Procedure" has not been satisfied, Edwards will not be responsible for any troubles.</p>	
--	--

Always contact Service office before returning the STP pump for repairs, overhaul, or other purposes.

To avoid any accident by gases or corrosion inside the STP pump and electrical parts, particularly when corrosive, reactive or flammable gases have been used:

- Vacuum and hermetically seal the STP pump before transport.
- Specify the type of gases used and handling precautions in the "Return Declaration".
- When returning the STP pump to Edwards, be sure to pack it well to prevent external damage. Use similar or superior packaging material as originally supplied.

"Return Procedure" and the "Return Declaration" are included at the end of the Instruction Manual. When additional sheets are needed, contact the Service office.

Note: The costs of cleaning and overhaul of the STP pump will be at the customers charge.

Note: When returning the STP pump to Edwards, fill in the necessary items in the "Return Declaration" and fax it to Service office.



STP-iXA3306 Series Turbomolecular Pump

This page intentionally blank.

9 STORAGE AND DISPOSAL

9.1 Storage of the STP pump

When planning not to use the STP pump over a long period (more than a few months), follow the precautions below:

1. Store the STP pump in a vertical position.
2. Close the inlet port of the STP pump and vacuum it using a backing pump.
3. Introduce dry N₂ gas or dry air from the outlet port or the purge port.
4. Close the outlet port and purge port.
5. If the STP pump is water cooled, introduce compressed air from one side of the cooling water port so that no water remains in the STP pump.
6. DO NOT store the STP pump in the following areas:
 - Areas of high humidity, (if it must be stored in a place of high humidity, insulate it from the outside and use a dehumidifying agent.)
 - Areas prone to temperature extremes. High temperatures of no more than +55 °C (131 °F), and low temperatures of less than –25 °C (13 °F).
 - Areas where corrosive gases may exist.
 - Areas subjected to water/dampness.
 - Areas subjected to excessive dust.
 - Areas with insufficient ventilation.
 - Areas subjected to strong magnetic and electric fields or radiation.
 - Areas which will be subjected to direct sunlight.
 - Areas subjected to mist.
 - Areas subjected to electric noise and vibration.

9.2 Disposal

	<p style="text-align: center;">WARNING</p> <p>When disposing of the STP pump, exhaust gases inside the STP pump thoroughly. Residual gases may result in an accident when disposing of the STP pump. If the STP pump has been used with reactive or corrosive gasses, always clean thoroughly before disposing of it to avoid any injury. Confirm the characteristics of gas to be used, referring to the Material Safety Data Sheet (MSDS) you obtain from the gas supplier.</p>
---	--

Dispose of the STP pump as industrial waste in accordance with all local and national safety and environmental standards.

Note: Edwards will not be responsible for problems during or after disposal.

10 SERVICE, SPARES AND ACCESSORIES

10.1 Introduction

Edwards products, spares and accessories are available from Edwards companies and from a network of distributors, which are listed on the last page of this document. A majority of these centres employ Service Engineers who have undergone comprehensive Edwards training courses. Order spare parts and accessories from your nearest Edwards company or distributor. When you order, state for each part required:

- Model and parts number of your STP pump
- Serial number (if any)
- Item number and description of part

10.2 Service

Edwards products are supported by a world-wide network of Edwards Service office. Each Service office offers a wide range of options including: equipment decontamination; service exchange; repair; rebuild and testing to factory specifications. Equipment, which has been serviced, repaired or rebuilt, is returned with a full warranty.

Your local Service office can also provide Edwards engineers to support on-site maintenance, service or repair of your equipment.

For more information about service options, contact your nearest Service office or Edwards.

10.3 Spares

Touch down bearing: When exchanging, contact the Service office. Touch down bearing should be replaced in Service office.

Air-cooling fan: When exchanging, contact Service Office. Air-cooling fan should be replaced in Service office.

Battery for clock function: When exchanging, contact Service Office. Battery for clock function should be replaced in Service office.

The possession periods of maintenance parts is for at least 7 years after the products is discontinued.

Contact Service office, when replacement is required.

STP-iXA3306 Series Turbomolecular Pump

10.4 Accessories

The following is a list of accessories that can be purchased by contacting Edwards.

Items	Application purpose	Remarks
Instruction Manual	STP Pump Instruction Manual	This manual Supplied with STP pump
Power cable	Primary input power	Standard cable length is 5 m. 10 m and 20 m versions are available. Contact Edwards for further information.
TMS unit *1	Control the STP pump temperature	TMS heater and TMS valve are included
STP-Link *1	Windows application for operating or monitoring the STP pump, or setting various settings.	Dedicated communication cable is included (3m)
Display unit (IDT-001) *1	Unit for operating or monitoring the STP pump, or setting various settings.	Dedicated communication cable is included (3m)

*1 Optional accessory

For more information, contact the nearest Service Office.

Manufacturer:

Edwards Japan Limited

1078-1, Yoshihashi, Yachiyo-shi, Chiba 276-8523 JAPAN

Telephone:	Domestic	047-458-8853
	International	+81-47-458-8853
Facsimile:	Domestic	047-458-8048
	International	+81-47-458-8048