

Instruction Manual

Seiko Seiki STPH803C/H1303C/H803CI (P033) Turbomolecular Pump System

(Document number MT-33E-002-F & MT-33E-0A1-C)



**STP-H803/H1303 Series
Turbomolecular Pump
INSTRUCTION MANUAL
(Second Edition- f)**

Read through the Safety Precautions and each section of this Manual carefully before using the STP pump.

Keep this Manual in a place where you can quickly access it at any time.

SAFETY PRECAUTIONS

The Safety Precautions in this Manual constitute guidelines to protect operators, the STP pump and its peripheral equipment. To avoid personal injury and prevent product and/or peripheral equipment damage, observe the Safety Precautions as well as the general safety rules (your country's laws, regulations, safety standards and so on). If the equipment is used in a manner not specified by BOC Edwards, the protection provided by the equipment may be impaired.

SYMBOLS

The following symbols are used in this manual:



Death or Serious Personal Injury

Failure to follow the guidelines marked with this symbol may result in death or serious personal injury.



Minor Personal Injury, Product and/or Peripheral equipment Damage

Failure to follow the guidelines marked with this symbol may result in minor personal injury, product and/or peripheral equipment damage.



Items you must follow during operation and maintenance.



ATTENTION : refer to this manual.

BOC Edwards Japan Limited (hereafter called BOC Edwards) cannot perfectly anticipate circumstances of all of hazards or problems. The scope of anticipation is limited to the precautions included in the



and



specified in this manual.



- ◇ The STP pump is provided with a high-speed rotor. Secure the STP pump according to the specified method. Failure to do so may lead to serious personal injury, product and/or peripheral equipment damage if any abnormality/error occurs in the rotor.
- ◇ The STP pump operates at high temperatures while the baking heater or the Temperature Management System (TMS) unit is in operation. NEVER touch the STP pump and its peripheral equipment while the baking heater or TMS unit is in operation. Operators can burn hands.
- ◇ Execute the following to prevent an accident caused by the gas.
 - Check the properties of the gas to be used, referring to the Material Safety Data Sheet (MSDS) you obtain from the gas supplier. (explosive · combustible · toxic · corrosive, etc) And, keep MSDS and a safety advice of gas supplier.
 - Warn of the danger of the gas with the warning label when the use gas is hazardous chemical materials.
 - Always execute gas purge in the pump with the inert gas, and then exhaust residual gases thoroughly from the STP pump when removing the STP pump from the vacuum equipment.
 - Secure safety by wearing personal protective equipment when using the gas which might influence damage health. In addition, take appropriate measure for depending upon the properties of the gas to be used.
- ◇ Exhaust residual gas thoroughly when disposing of the STP pump. If the STP pump is used for any toxic or reactive gas, always clean the STP pump and dispose of it as industrial waste in accordance with guidelines given by the national and/or local government. Residual gas in the STP pump may cause an accident which, for certain gases, may involve serious injury or death.



- ◇ **NEVER** use any gas that is not specified as usable in this Manual. The use of such gas may corrode the STP pump and damage it.
- ◇ **A hazardous live voltage may exist at connector/terminal that marked**  .
DO NOT touch the terminal. Doing so may result in electric shock. When operating connection/disconnection to connector, always power **OFF** the STP pump (Switch the breaker "OFF").
- ◇ **Always check the STP pump has stopped, then turn OFF the primary power (switch the breaker "OFF") before proceeding to any of the following operations. Failure to do so may cause the STP pump to rotate accidentally, which may injure operators seriously or result in electric shock. Moreover, do not remove the connector while the pump is rotating. The voltage might be output to connector according to the rotational speed, and it causes the electric shock or the failure.**
 - **Connect or disconnect cables;**
 - **Perform maintenance such as replacement of fuses;**
 - **Perform inspections such as deposit and/or the air cooling fan; or**
 - **Perform investigations into probable causes and action/measures taken in the event of occurrence of a problem.**
- ◇ **Do not perform the insulation test (insulation resistance test and withstand voltage test) to the STP control unit and STP pump. When performing the insulation test to your equipment, turn "OFF" the STP control unit. The varistor for the power supply line protection is installed to the STP control unit. DO NOT perform the insulation test with the varistor installed. Doing so may result in product damage.**
- ◇ **When "emergency off" (EMO) circuit is installed in the vacuum equipment, consider the following to stop the STP pump safely when the EMO circuit operates.**
 - **When the EMO circuit operates, atmosphere might be introduced in the STP pump depending upon the backing pump. Unite the exhaust gas system to prevent atmosphere from being introduced into the STP pump when the EMO circuit operates. (example: shut the valve) When atmosphere is introduced into the STP pump, the touch down bearing may not operate normally.**



- ◇ **When removing or installing the pump or at maintenance and inspection, follow the precautions below. Failure to do so might hurt your back or cause injuries due to occurrence of an accident such as fall.**
 - **Use a crane or the like when lifting the heavy product of 18kg or more.**
 - **When lifting by hands for unavoidable reason, two or more people must always conduct it.**
 - **When lifting STP control unit with handles, support bottom of STP control unit, do not have only handle.**
- ◇ **Install the STP control unit not only by fitting it with the front panel fitting screws but also by supporting it from the bottom side. Fitting the STP control unit with the screws only cannot sustain its weight, and therefore resulting in product damage.**
- ◇ **Always use the STP pump and STP control unit with same model name, which are specified on their own nameplate. If you plan to use the units having different model names, an error message is indicated and they may not be used. In the latter case, contact Service office. If you plan to use the units having the same model name but different serial numbers, an error message is indicated when they are used without tuning. And, the tuning is necessary when the length of the STP connection cable is changed. They may not function normally when they are used without tuning. Once tuning is completed, re-tuning is not required unless the configuration (the STP pump serial number, the STP control unit serial number, and the STP connection cable length) is changed.**
- ◇ **Use the STP connection cable that BOC Edwards has specified. The use of different cables may result in product damage.**
- ◇ **Connect the cables securely. NEVER bend nor place heavy objects on the cable. Doing so may result in electric shock or product damage.**
- ◇ **NEVER remove the splinter shield from the STP pump. Doing so may result in product damage.**
- ◇ **DO NOT put foreign objects into the STP pump. Doing so may result in product damage.**
- ◇ **Always use the power voltage specified on the nameplate for the primary power voltage of the STP control unit. Wire the power cable securely. Incorrect wiring may result in electric shock or product damage.**
- ◇ **The wipes used for clean the flange of the pump might become hazardous waste depending upon the solvent (alcohol). Dispose of the contaminated wipes appropriately according to the regulations of each national and/or local government.**



- ◇ **NEVER** turn OFF the primary power (DO NOT switch the breaker "OFF") while the STP pump is rotating. Doing so may result in product damage.
- ◇ **Perform investigations into probable causes and remove them before restarting the STP pump in the event of the occurrence of a problem. The use of the abnormal STP pump may result in product damage.**
- ◇ **DO NOT** move the STP pump and the STP control unit while the STP pump is in operation. Doing so may result in product damage.

INTRODUCTION

Thank you very much for purchasing BOC Edwards' turbomolecular pump. The turbomolecular pump is designed to be installed in the vacuum equipment to exhaust gases from it.

This manual covers all items necessary to ensure safe installation, operation and maintenance of the following series of the STP-H803/H1303 turbomolecular pump:

Model Name	Specification
• STP-H803C	High-throughput type, chemical specific *1
• STP-H803CV	High-throughput type, chemical specific, TMS unit*2 attached
• STP-H1303C	High-throughput type, chemical specific
• STP-H1303CV	High-throughput type, chemical specific, TMS unit attached

For the specifications of other models of the STP-H803/H1303 pump series, contact BOC Edwards.

In this manual, the above STP-H803/H1303 pump series is collectively referred to as the "STP pump."

*1 : Chemical specific: STP pump with anti-corrosive treatment
(responding to chlorine, fluorine or other system gases)

*2 : TMS: Temperature Management System

APPLIED STANDARDS

The STP pump conforms to the following directives and standards:

- ◇ Applied Directives
 - EC Machinery Directive
 - EC Electromagnetic Compatibility Directive
 - EC Low Voltage Directive

- ◇ Applied Standards
 - EN1012-2
 - EN61010-1
 - EN61326 (class A)
 - EN61000-6-2

- ◇ Applied Standards (Only a some model)*¹
 - UL3101-1, 1993 (Electrical Equipment for Laboratory Use; Part 1 : General Requirements)

PRECAUTIONS

- 1) No part of this manual may be reproduced in any form by any means without prior written permission from BOC Edwards.

- 2) BOC Edwards pursues a policy of continuing improvement in design and performance of this product. The right is, therefore, reserved to vary specifications and design without notice. Understand that the product you purchased and its contents including specifications described in this manual may differ.

REQUEST

If you find inaccuracies or errors in this manual, advise distributor or the nearest Service office.

*¹ : Contact BOC Edwards about recognized model.

LIMITED WARRANTY

This WARRANTY applies to the customer to whom BOC Edwards has delivered this product.

1. WARRANTY PERIOD:

BOC Edwards warrants this product against defects for a period of two (2) years from the date of delivery or during the period specified in the agreement made by and between the customer and BOC Edwards.

2. ITEM WARRANTED:

- 1) This warranty applies only to the product delivered from BOC Edwards to the customer.
- 2) If any defect is found during this period, BOC Edwards will, at its option, repair or recondition the product free of charge. The costs for repair or replacement of the product after the warranty period has passed will be at your own charge.

3. DISCLAIMER:

BOC Edwards makes no warranty with respect to any damage occurred due to any of the following during the warranty period:

- 1) **Handling, operation or maintenance other than that specified herein;**
- 2) **Failure to follow any of the warnings or cautions enumerated under**

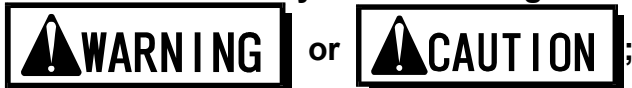

- 3) **Installation, operation or maintenance using parts which are not specified by BOC Edwards;**
- 4) **Maintenance personnel other than those authorized by BOC Edwards or Service office have disassembled, reconditioned, or tampered the product;**
- 5) **Defect resulting from the not-specified use of the product;**
- 6) **When the product is used under special conditions without obtaining the written consent of BOC Edwards (Particular gases, strong magnetic field and the radiation are added to the product.);**
- 7) **Defect resulting from deposit;**
- 8) **Water cooling system defect resulting from water quality used;**
- 9) **Defect resulting from the installation of the product (Exclude the installation by authorized personnel.);**
- 10) **Deterioration in the external because of use (Discoloration, scratches and so forth);**
- 11) **Product damage occurred during transport or other factors not attributable to BOC Edwards;**
- 12) **Product breakage or damage due to natural disasters, fire or other**

external factors;

- 13) Deterioration in the basic performance due to the use of the product beyond limits of the use;**
- 14) Any direct, incidental or consequential damage resulting from the use of the product;**
- 15) When continuously operated without overhaul after the WARNING indication ("WARNING" message) on the LCD display;**
- 16) Overhaul and replacement of maintenance parts;**

4. SPARE PARTS:
 - Fuse and air cooling fan for control unit
 - Touch down bearing
 - Heater

TABLE OF CONTENTS

SAFETY PRECAUTION

INTRODUCTION

APPLIED STANDARDS

PRECAUTIONS

REQUEST

LIMITED WARRANTY

1	Precautions for Safe Operation of the STP Pump.....	1-1
1.1	Usable Gases	1-1
1.2	Maintenance and Inspection Precautions.....	1-1
1.3	Labels.....	1-2
2	Operation Principle of the STP Pump	2-1
3	Unpacking.....	3-1
3.1	Unpacking the STP Pump and the STP Control Unit	3-1
3.2	Accessories.....	3-2
4	Installation of the STP Pump.....	4-1
4.1	Name and Function of Each Part.....	4-1
4.2	Precautions Before Installation	4-3
4.2.1	Operating Environment.....	4-3
4.2.2	Installation Area	4-4
4.2.3	Bench	4-4
4.3	How to Install the STP Pump.....	4-6
4.3.1	Cleaning the Seal.....	4-7
4.3.2	STP Pump Installation Positions.....	4-8
4.3.3	How to Secure the STP Pump.....	4-9
4.3.4	Vacuum Piping.....	4-13
4.3.5	Connecting the Purge Port	4-15
5	Gas Pumping, Cooling and Baking the STP Pump.....	5-1
5.1	Gas Pumping	5-1
5.1.1	How to Introduce a Purge Gas	5-1
5.2	Cooling the STP Pump	5-2
5.2.1	Water Cooling Method	5-2
5.3	Baking the STP Pump.....	5-3
5.3.1	Attaching a Baking Heater	5-3
6	Installation of the STP Control Unit	6-1
6.1	Name and Function of Each Part.....	6-1
6.1.1	Front Panel	6-1
6.1.2	Rear Panel.....	6-4
6.2	Precautions Before Installation	6-5
6.2.1	Operating Environment.....	6-5
6.2.2	Insulation Test.....	6-5
6.2.3	Installation Area	6-7

6.3	Attaching the STP Control Unit to a Rack.....	6-8
6.4	Cable Connection	6-9
6.4.1	Name and Dimensions of Each Cable.....	6-9
6.4.2	How to Connect the Cables	6-12
6.5	Connecting to Semiconductor Equipment	6-14
6.5.1	Connecting to Power.....	6-14
6.5.2	Emergency Off Circuit (EMO Circuit).....	6-14
7	How to Start/Stop the STP Pump.....	7-1
7.1	Before Starting	7-1
7.2	Start Procedures	7-2
7.3	Stop Procedures	7-2
7.4	Manual Operation	7-3
7.4.1	Powering ON.....	7-3
7.4.2	Starting the STP Pump	7-3
7.4.3	Stopping the STP Pump	7-4
7.4.4	Starting the STP Pump after Stopping.....	7-4
7.4.5	Powering OFF	7-4
7.4.6	Starting the STP Pump after a Safety Function Operates.....	7-4
7.5	Remote Operation.....	7-5
7.5.1	Powering ON.....	7-5
7.5.2	Starting/Stopping the STP Pump	7-5
7.5.3	Starting the STP Pump after Stopping.....	7-6
7.5.4	Powering OFF	7-6
7.5.5	Starting the STP Pump after a Safety Function Operates.....	7-6
7.6	Operating the TMS Unit (For use with the TMS unit only).....	7-7
7.6.1	Starting/Stopping	7-7
7.6.2	Temperature Control.....	7-7
8	Remote Input/Output Signal Connector	8-1
8.1	Input Signal Pins	8-1
8.2	Output Signal Pins	8-4
9	Adjustment Methods	9-1
9.1	Tuning	9-1
9.1.1	Tuning Method	9-1
9.1.2	Each of data after tuning.....	9-2
9.2	Confirmation Mode.....	9-4
9.3	Parameter Set Mode.....	9-6
10	Safety Functions	10-1
10.1	Power Failure.....	10-1
10.2	Abnormal State of Magnetic Bearing	10-3
10.3	Excessive Vibration.....	10-3
10.4	Motor Driver Overload.....	10-3
10.5	Overheating Inside the STP Pump	10-3
10.6	Overheating Inside the STP Control Unit.....	10-4
10.7	Overspeed.....	10-4
10.8	Abnormality/Error in the TMS Unit (for Use with the TMS Unit)	10-4
11	Troubleshooting, Maintenance, and Inspection.....	11-1
11.1	Troubleshooting Immediately after an Abnormality/Error Occurs.....	11-1
11.1.1	Troubleshooting Power Failure.....	11-1
11.1.2	Troubleshooting Other Abnormality/Error	11-1
11.2	When Error Message is Displayed on LCD	11-2
11.2.1	Error Messages.....	11-2
11.3	Other Abnormalities	11-8

11.3.1	Abnormalities When Powering ON	11-8
11.3.2	Abnormalities When Performing the STP Pump Start Operation	11-8
11.3.3	Other Abnormalities	11-9
11.4	"WARNING" Message Display Function	11-10
11.4.1	First Damage Limit	11-10
11.4.2	Second Damage Limit	11-11
11.5	"ERROR RECORD" Message Display Function	11-11
11.6	Maintenance and Inspection	11-12
11.6.1	Cleaning and Decontamination	11-13
11.6.2	Inspecting the Deposit	11-14
11.6.3	Overhaul	11-15
11.6.4	Transporting for Repair or Overhaul	11-16
12	Storage and Disposal	12-1
12.1	Storage of the STP Pump	12-1
12.2	Storage of the STP Control Unit	12-1
12.3	Disposal	12-2
13	Specifications	13-1
13.1	Specifications for the STP Pump	13-1
13.2	Specifications for the STP Control Unit	13-5

UNIT CONVERSION TABLE

ANNEX

MALFUNCTION INFORMATION
SERVICE OFFICE LIST

TABLES

Table 3.1	Accessories	3-2
Table 4.1	Tightening torque of bolt.....	4-9
Table 4.2	Maximum Torque predicted and Recommended securing bolt for inlet port flange	4-10
Table 4.3	Number of Claw Clamps by Size of Flange.....	4-11
Table 6.1	Connecting the Power Cable.....	6-13
Table 7.1	Starting/Stopping the STP Pump during Remote Operation (REMOTE X7)	7-5
Table 7.2	Reset Operation during Remote Operation (REMOTE X7)	7-6
Table 8.1	REMOTE X7 Input Signal Pins.....	8-2
Table 8.2	REMOTE X7 Output Signal Pins.....	8-4
Table 8.3	Rated Contacts for Relays CR1 to CR8	8-7
Table 9.1	Data List.....	9-2
Table 10.1	States of Lamps and REMOTE Output Signals at a Power Failure.....	10-2
Table 10.2	Operations of the STP Pump after a Power Recovery.....	10-2
Table 10.3	Safety Functions	10-6
Table 10.4	Safety Functions (When the TMS Unit is Used).....	10-8
Table 11.1	Error Messages	11-3
Table 11.2	Troubleshooting after Powering ON.....	11-8
Table 11.3	Troubleshooting When Performing the STP Pump Start Operation	11-8
Table 11.4	Troubleshooting While the STP Pump Is Rotating	11-9
Table 11.5	Cleaning and Decontamination	11-13
Table 13.1	Specifications for the STP Pump.....	13-1
Table 13.2	Specifications for the STP Control Unit	13-5

FIGURES

Figure 2.1	Cross Sectional View of the STP Pump	2-2
Figure 3.1	Example of Lifting the STP Pump.....	3-2
Figure 4.1	Configuration of the STP Pump.....	4-2
Figure 4.2	Installation of the STP Pump to the Vacuum Equipment	4-6
Figure 4.3	STP Pump Installation Positions	4-8
Figure 4.4	Positions of the Outlet Port on the Horizontally or Slanted Installed STP Pump	4-8
Figure 4.5	Example of securing the STP pump (When securing the inlet port with bolts)	4-10
Figure 4.6	Shape of Reduced Diameter Shank Bolts.....	4-11
Figure 4.7	Example of securing the STP pump (When securing the inlet port flange with claw clamps)	4-12
Figure 4.8	Example of securing the STP pump (When installing the damper in the inlet port flange).....	4-12
Figure 4.9	Connecting the Purge Port	4-15
Figure 5.1	Attaching Positions of the Cooling Unit and Baking Heater	5-4
Figure 6.1	STP Control Unit Front Panel	6-3
Figure 6.2	STP Control Unit Rear Panel.....	6-5
Figure 6.3	Peripheral Space of the STP Control Unit.....	6-7
Figure 6.4	Example of Securing the STP Control Unit	6-8
Figure 6.5	External Dimensions of Each Cable.....	6-9
Figure 6.6	External Dimensions of Each Cable.....	6-10
Figure 7.1	STP Pump Operation Procedures.....	7-8
Figure 8.1	REMOTE X7 Input Signal Pins.....	8-3
Figure 8.2	REMOTE X7 Output Signal Pins.....	8-6
Figure 9.1	Tuning Procedures	9-3
Figure 9.2	Confirmation Mode Operation Method	9-5
Figure 9.3	Parameter Setting Method.....	9-7
Figure 9.4	Remote Mode Setting Method.....	9-8
Figure 13.1	External Appearance of the STP Pump (STP-H803 Series).....	13-2
Figure 13.2	External Appearance of the STP Pump (STP-H1303 Series).....	13-3
Figure 13.3	Label Affixing Positions for the STP Pump.....	13-4
Figure 13.4	External Appearance of the STP Control Unit.....	13-7
Figure 13.5	Label Affixing Positions for the STP Control Unit.....	13-8

1 Precautions for Safe Operation of the STP Pump

1.1 Usable Gases

The STP series models are chemical specific pumps: chlorine or fluorine system gases can be used. When you use gases including alkaline metals, but excluding Li, gases including Ga, Hg, In, or Sn, or HBr, contact BOC Edwards.



- ◇ To prevent an accident, confirm the characteristics of gases to be used, referring to the Material Safety Data Sheet (MSDS) you obtain from the gas supplier.
And, keep MSDS and a safety advice of gas supplier.



- ◇ Introduce a dry N₂ gas (purge gas) to protect the inside of the STP pump when using reactive or corrosive. The use of reactive or corrosive gas may result in product damage.
- ◇ Cool the STP pump to prevent the STP pump from overheating when pumping gases.

1.2 Maintenance and Inspection Precautions



Perform any maintenance or inspection of the STP pump and the STP control unit, following Section 11, "Troubleshooting, Maintenance and Inspection."

1.3 Labels

The following labels are affixed to the STP pump and STP control unit. Read the contents of the labels before operation. For the positions of the labels, see Section 13, "Label Affixing Position."



1) STP Pump Caution Label

This label describes precautions for operating the STP pump. Follow these precautions.

 注意	 CAUTION
◇必ず指定の型式のケーブルを使用してください。	◇Use only designated type of cables.



2) STP Control Unit Caution Label

This label describes precautions for operating the STP control unit. Follow these precautions.

 注意	 CAUTION
◇ポンプとコントロールユニットを異なるNoの組合せで使用する場合、接続ケーブル長を変更する場合は取扱説明書に従い調整を行ってください。 ◇必ず指定の型式のケーブルを使用してください。	◇Adjust levitation according to instruction manual, if pump and control unit have different serial number or you change connection cable length. ◇Use only designated type of cables.

3) Heavy Product Caution Label

This label is affixed to the product with a weight of 18 kg or more. Follow the precautions of Section 2, "Unpacking" so as not to cause any accident during handling.

 注意		 CAUTION
重量物 k g 取扱注意		Heavy product k g Handle with caution.

4) STP Pump Installation Warning Label

This label describes installation of the STP pump.

Install the STP pump according to the precautions of Section 4, "Installation of the STP Pump."

 警告	 WARNING
ポンプは取扱説明書の指示に従い確実に固定してください。	Install pump securely according to instruction manual.



5) STP Control Unit Safety Instruction Label

This label describes instructions before operating the STP control unit.

安全上の指示事項	SAFETY INSTRUCTIONS
使用前に取扱説明書をお読みください。	Read instruction manual before operation.

6) Connector Caution Label

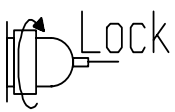
- ◇ This label describes lock of the connector.
- ◇ This label instructs operators to prevent the connectors from being disconnected while the STP pump is in operation.

 注意		 CAUTION
<ul style="list-style-type: none"> ◇ コネクタは確実にロックしてください。 ◇ ブレーカONの時はコネクタを外さないでください。 		<ul style="list-style-type: none"> ◇ Lock connector securely. ◇ Do not remove connector while breaker is ON.

7) Rotational Direction Instruction Label

This label describes the rotational direction of the STP pump.
The STP pump rotates in this direction.



8) High Voltage Device Caution Label

The STP control unit is equipped with a high voltage device. This label warns operators to pay attention to the high voltage device.

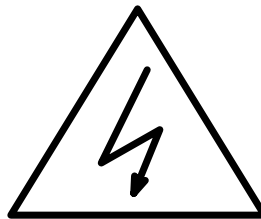

9) Voltage Rating Label

This label describes the rated voltage of the STP control unit.
Use voltage specified in this label.



10) Hot Surface Warning Label

This label instructs operators so as not to touch the hot surface of the STP pump.

The use of the TMS unit may lead to a considerable rise in temperatures outside the STP pump.

This label warns operators so as not to burn hands.

(only when using the TMS unit)

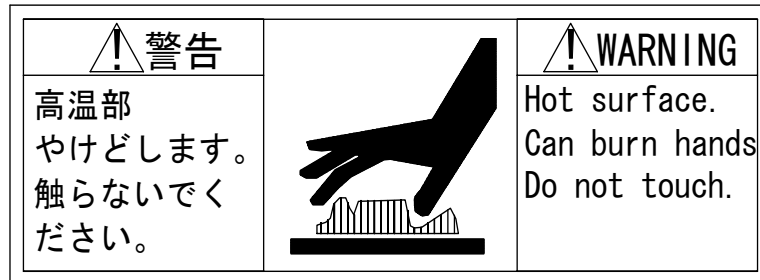

2 Operation Principle of the STP Pump

The STP series pump is a series of a magnetically-levitated turbomolecular pumps, featuring the following:

- Oil free
- Low vibration
- High reliability

The STP pump is configured so that rotor blade (1) and stator blade (2) are aligned alternately in the axial direction. Gas molecules are pumped from the inlet port to the outlet port by the high speed rotation of the rotor.

The STP pump is configured with a screw channel pump and turbine blade together in the lower side of rotor blade (1) for high-throughput even at a low vacuum range (a few hundred Pa (a few Torr)).

Rotor blade (1) is supported by the magnetic bearing without mechanical contact. Therefore, the STP pump requires no lubrication oil unlike conventional turbomolecular pumps using ball bearings.

The magnetic bearing consists of 5 pairs of active magnetic bearings. The rotor is supported in the radial direction by 4 pairs of radial direction active magnetic bearings that consist of radial sensor (3) and radial electromagnet (4). A pair of axial direction active magnetic bearings consists of axial sensor (5) and axial electromagnet (6) to support the rotor in the axial direction. Because the rotor is supported without mechanical contact, it can rotate at low vibration.

There is less heat generated from magnetic bearings because there is no friction. Therefore the STP pump requires no cooling. However, the STP pump requires water or air cooling during baking and gas pumping. Taking into consideration a breakage of magnetic bearings, touch down bearings (7) coated with solid lubrication have been installed. They do not contact with the rotor during the rated operation.

A radial sensor, an axial sensor, a rotational speed sensor and a temperature sensor always monitor the magnetic bearing as well as the rotor. If an abnormality/error occurs, the rotor will stop.

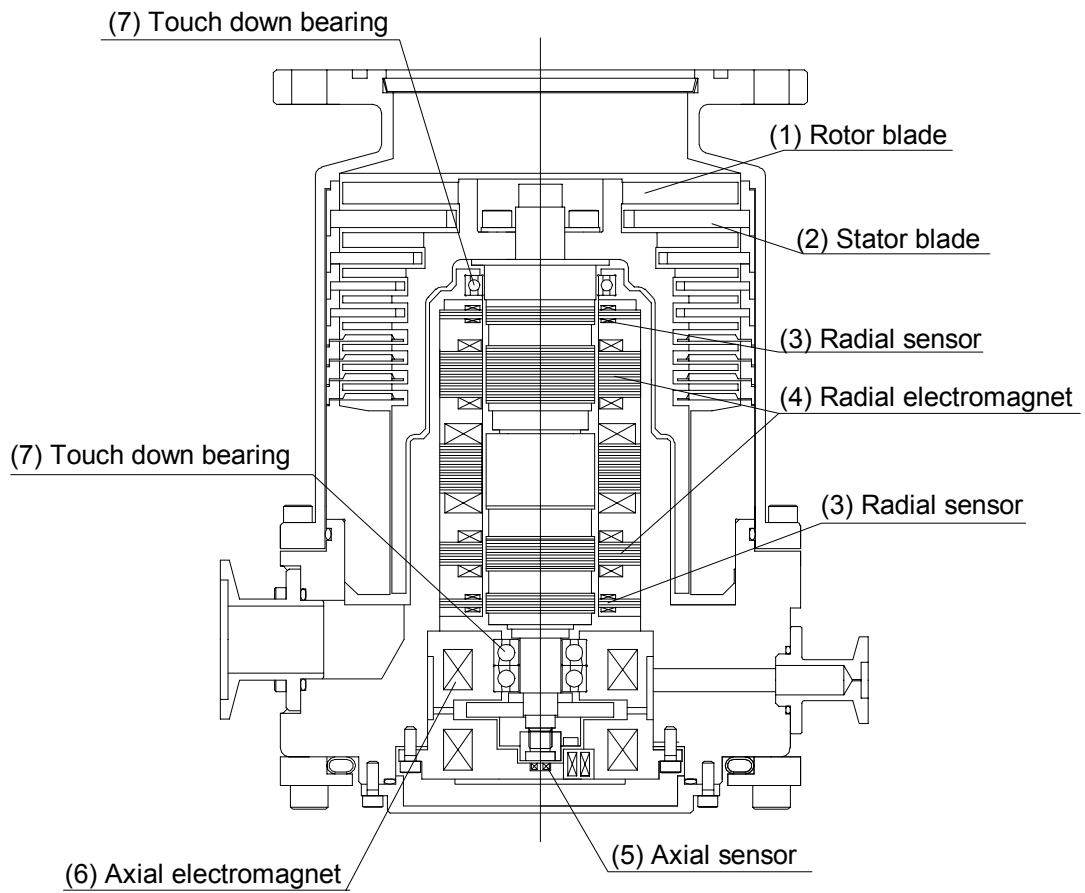

Figure 2.1 Cross Sectional View of the STP Pump

3 Unpacking

3.1 Unpacking the STP Pump and the STP Control Unit

Check the following before unpacking the STP pump and STP control unit.

- Check the package for bruises, breakage, wetness, and other. If there is any abnormality/error or it is judged necessary to return the product, contact BOC Edwards or the selling agency.
- Check the contents of the package. See Section 3.2, "Accessories."

CAUTION

- ◇ **The net weight of the STP pump is approx. 39 kg. Use a crane or other appropriate means to lift the STP pump. Lift the STP pump with an eyebolt or a similar tool that uses the fitting hole attached to the inlet port flange. Lift it with the aid of a suspension tool under the base when installing the STP pump without fitting hole.**
- ◇ **Observe national laws/regulations, safety standards and so on when lifting the STP pump.**
- ◇ **Use a crane or other appropriate means sufficient enough to withstand the load when lifting the STP pump.**
- ◇ **Always lift the STP pump in stable places free of excessive shock or vibration to prevent it from shaking or dropping.**
- ◇ **Have at least two people lift the STP pump when doing so by hand.**

NOTICE

- ◇ **Be careful not to scratch the flange of the STP pump. Before installing the STP pump, check whether or not there are scratches on the surface.**
- ◇ **It is recommended to keep the packaging materials, such as the corrugated fiberboard container and cushioning material for possible reuse.**

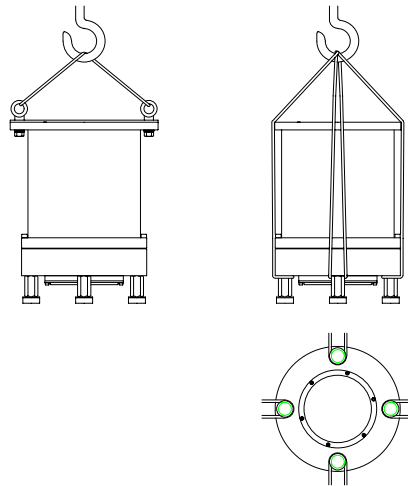

Figure 3.1 Example of Lifting the STP Pump

3.2 Accessories

Table 3.1 Accessories

Item	Q'ty	Remarks
STP control unit	1	
Primary power cable* ¹	1	With a single-side connector
STP connection cable* ¹	1	With both-side connectors
Inlet port cover	1	
Outlet port cover	1	
STP connector cover	1	
Blank flange for purge port	1	KF10
Clamping ring for purge port	1	KF10
O-ring washer for purge port	1	KF10
Leg	8	4 legs are attached to the STP pump
Rubber foot for leg	4	
Instruction Manual	1	

*¹ : The standard cable length is 5 m. Both 10 m and 20 m are available. Contact BOC Edwards on other specifications.

4 Installation of the STP Pump

4.1 Name and Function of Each Part

- (1) Inlet Port Flange (VG^{*1}, ICF^{*2}, ISO, and other)
 - Connected to the vacuum equipment (at the high vacuum side).
- (2) Outlet Port Flange (KF^{*1} 40)
 - Connected to the inlet port side of the backing pump.
- (3) STP Connector (60 pins)
 - Connected to the STP connection cable.
- (4) Purge Port (KF^{*1} 10)
 - Introduces a purge gas.
In order to protect the inside of the STP pump when pumping reactive or corrosive gases.
The STP pump is delivered with a blank flange attached to this port.
- (5) Cooling Water Port (PT^{*3} (RC^{*1}) 1/4 Female Screw)
 - Connected to the STP pump cooling water pipe.
This port is used when water cooling the STP pump or using the TMS^{*4} unit.
- (6) Temperature Sensor Connector (optional accessory)
 - A temperature sensor is attached.
For use with the Temperature Management System (TMS^{*4}) unit only (usually, a connector is not attached).

*1 : JIS

*2 : JVIS

*3 : Conform to ISO

*4 : Temperature Management System

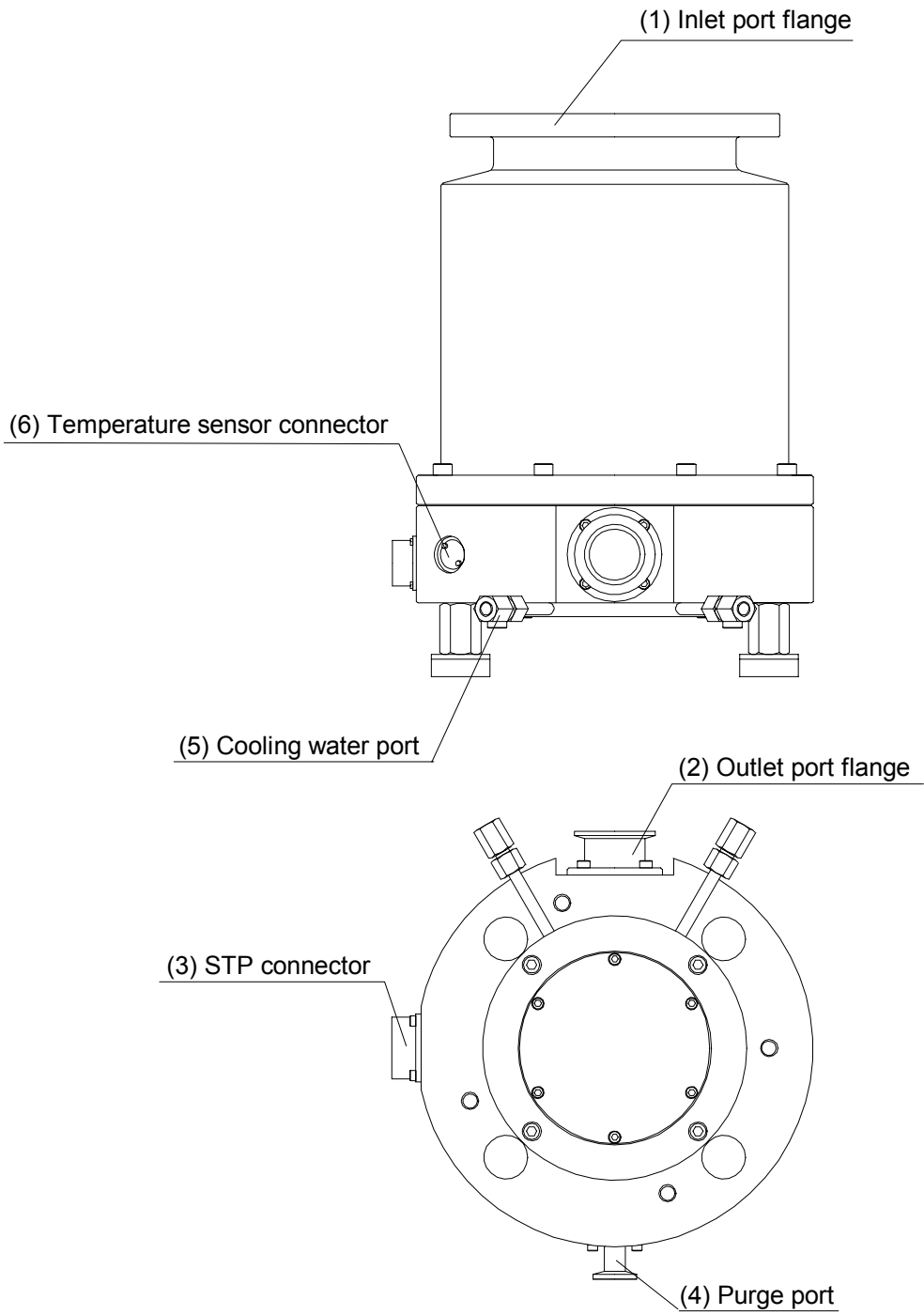

Figure 4.1 Configuration of the STP Pump

4.2 Precautions Before Installation

4.2.1 Operating Environment

WARNING

- ◇ Check the properties of the gas to be used, referring to the Material Safety Data Sheet (MSDS) you obtain from the gas supplier. And, keep MSDS and a safety advice of gas supplier. Take measures according to MSDS to prevent an accident when using toxic, reactive or combustible gases. Dilute the gas to be used with the inert gas controlled if necessary. And, take measures according to MSDS to prevent an accident caused by exhaust gas.

CAUTION

- ◇ The STP series models are chemical specific pumps: chlorine or fluorine system gases can be used with these models. When you use gases including alkaline metals, but excluding Li, gases including Ga, Hg, In, or Sn, or HBr, contact BOC Edwards (See Section 1.1, "Usable Gases").
- ◇ If the STP pump is used in an area with radiation, contact BOC Edwards.

Install the STP pump in a place meeting the following requirements:

Ambient Temperature	0 to 40 °C
Ambient Relative Humidity	30 to 95 % (no dew condensing)
Environment	<ul style="list-style-type: none"> • A place free of externally-applied mechanical shock. • A place free of a heat source (Keep clear of the heat source or attach a thermal shield plate). • A place free of a strong magnetic field (Range: up to <u>15 mT (150 G) in the axial direction</u>, and up to <u>3 mT (30 G) in the radial direction</u> with respect to the rotational axis of the STP pump). • A place free of a strong electric field. • A place free of exposure to radiation. • No discharge of high voltage (more than 500 V) (If more than 500 V is discharged, contact BOC Edwards).
STP Pump Installation Equipment Conditions	<ul style="list-style-type: none"> • Install the STP pump securely so that foreign materials will easily fall into the STP pump (Ex.: Si wafers or samples are positioned above the STP pump) (To prevent foreign materials from falling into the STP pump, design a shield plate with large conductance).

4.2.2 Installation Area

Leave enough space for the following in addition to that for the STP pump:

- Space for maintenance and inspection
- Space for connecting cables



- ◇ **The minimum bending radius of the STP connection cable is 100 mm (See Section 13, "External Appearance of the STP Pump" [bending dimensions of the connection cable]). DO NOT excessively bend the cables and beware of any obstacles when installing the STP pump. Also, leave enough space to install other cables without bending them excessively.**



- ◇ **The L-type STP connection cable is also offered. Contact BOC Edwards if necessary.**

4.2.3 Bench

A bench must be prepared by the customer to secure the STP pump. The shape and size of the bench differ depending upon the type of STP pump. Follow the precautions of the WARNING, CAUTION, or NOTICE (See Section 4.3.3, "How to Secure the STP Pump").



- ◇ **The STP pump is provided with a high-speed rotor. Any internal abnormality/error may result in a jump in rotational torque leading to personal injury or peripheral equipment damage. Design and secure the bench for the STP pump so that it can withstand the maximum torque generated due to the occurrence of an abnormality/error. Refer to Section 4.3.3, "How to Secure the STP Pump" for abnormal torque.**

 **CAUTION**

- ◇ **Secure the customer-prepared bench and the vacuum equipment on the floor or peripheral equipment and other equipment in accordance with the customer application. NEVER move them while the STP pump is in operation.**

 **NOTICE**

- ◇ **Confirm the dimensions by the external appearance of the STP pump when designing the bench.
The bolt may not be able to be inserted from the lower side of the inlet port according to the shape of the inlet port flange.
When the external appearance of the STP pump is not in the manual, contact BOC Edwards.**

4.3 How to Install the STP Pump

Install the STP pump to the vacuum equipment as shown in Figure 4.2.

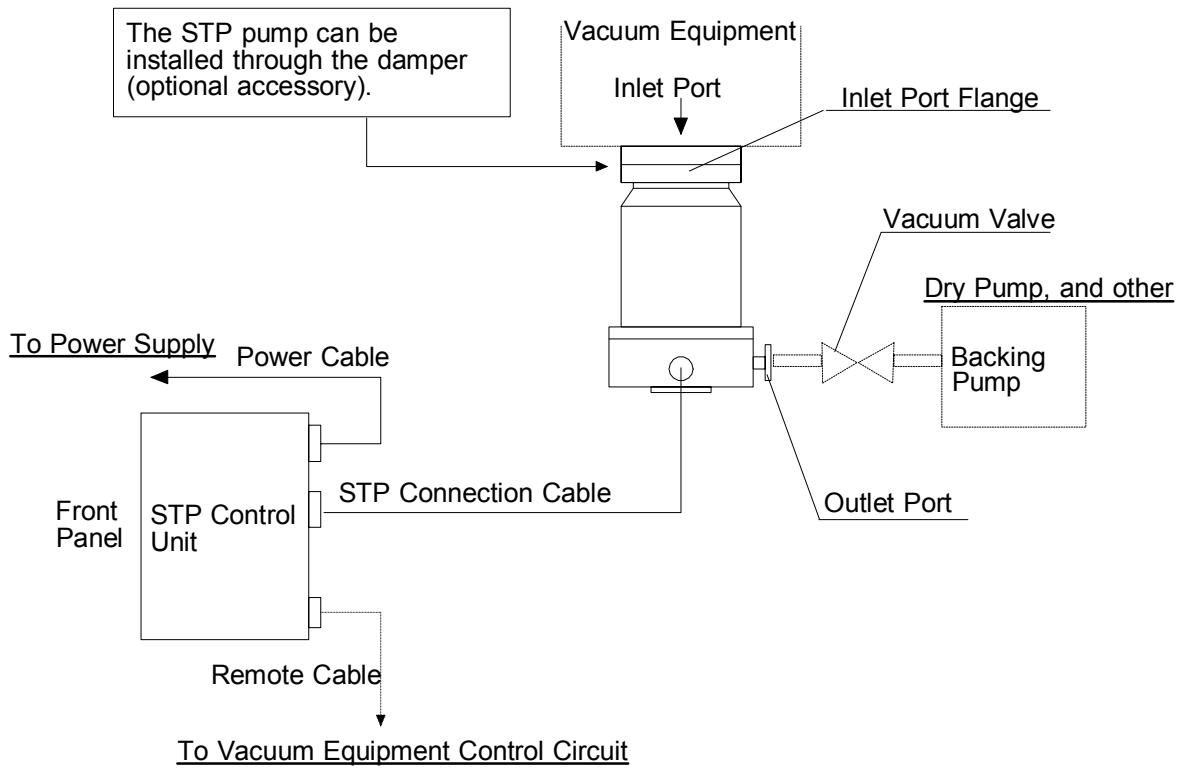

Figure 4.2 Installation of the STP Pump to the Vacuum Equipment

4.3.1 Cleaning the Seal

Inspect the seals of inlet and outlet port flanges for dirt or oil spots before installing the STP pump to the vacuum equipment.

Take the following measures for cleaning the seals:

- Clean off with a pure gas.
- Wipe with proper solvent (such as alcohol).



- ◇ **A splinter shield is attached to the inlet port flange to prevent foreign materials from falling into the STP pump. Always leave the splinter shield attached during operation.**
- ◇ **The wipes used for clean the flange of the pump might become hazardous waste depending upon the solvent (alcohol). Dispose of the contaminated wipes appropriately according to the regulations of each national and/or local government.**



- ◇ **The splinter shield cannot perfectly prevent foreign materials from falling into the STP pump. DO NOT install the STP pump in such a manner that foreign materials can easily fall into it (for example, Si wafers or samples are positioned above the STP pump). If installing the STP pump in such a manner, always attach a shield plate with sufficient conductance above the STP pump to prevent foreign materials from falling into it. Foreign materials falling into the STP pump through the splinter shield may result in product damage.**
- ◇ **Be careful not to scratch the flange of the STP pump. Check whether or not there are scratches on the surface, before installing the STP pump.**

4.3.2 STP Pump Installation Positions

The STP pump can be installed vertically, horizontally, upside-down and slanted.

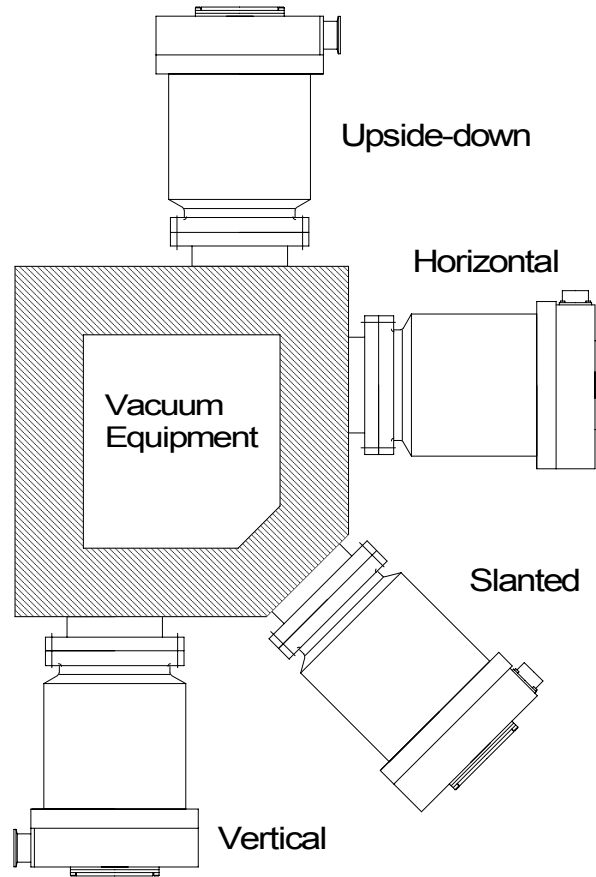

Figure 4.3 STP Pump Installation Positions

When installing the STP pump in a horizontal or slanted position, it is recommended to install it so that the direction of the outlet port is on a vertical or horizontal plane in the direction of the gravity.

This makes it possible to reduce the load on the magnetic bearing and the heat generated by the STP pump.

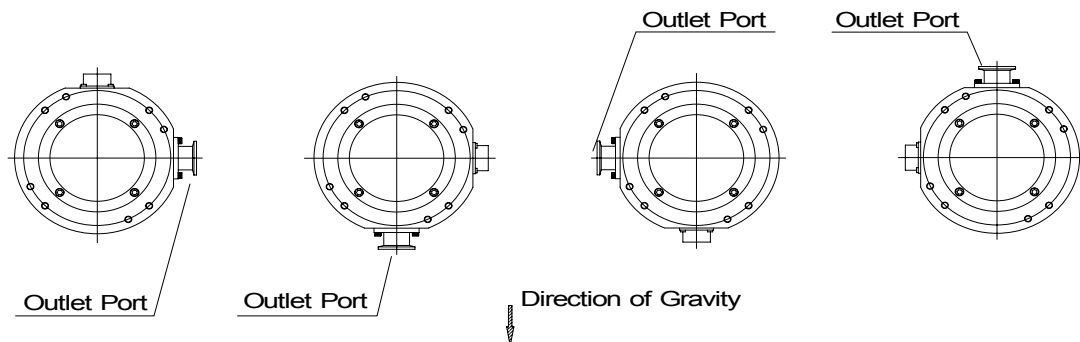
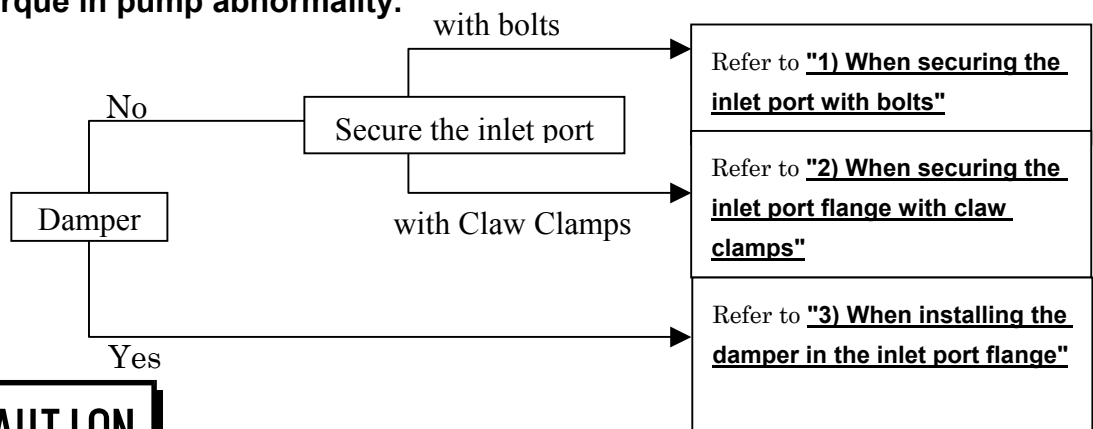

Figure 4.4 Positions of the Outlet Port on the Horizontally or Slanted Installed STP Pump

4.3.3 How to Secure the STP Pump



- ◇ The STP pump is provided with a high-speed rotor. The worst-case failure may result in a jump in rotational torque leading to personal injury or peripheral equipment damage. The method of securing the STP pump will depend on the installation requirements. Secure the STP pump to the vacuum equipment as follows:
- ◇ Design and secure the mounting for the STP pump so that it can withstand the maximum rotational torque. Refer to Table 4.2 for torque in pump abnormality.



- ◇ In some cases, the damper and the claw clamping cannot be used depend on the type of the STP pump.
- ◇ Refer to Table 4.1 for tightening torque of the bolt.

Table 4.1 Tightening torque of bolt

Size of bolt	Tightening torque of bolt (Nm)
M8	12.0
M10	24.1
M12	42.1

- ◇ When making the leg to secure the base, make them shortened more than ones attached to the STP pump. Use a material that has a tensile strength of 600N/mm² or more.
- ◇ When securing the base, use stainless steel securing bolts with a tensile strength class is 70 or more.



- ◇ When using any securing method other than that specified in this manual, contact BOC Edwards.

1) When securing the inlet port with bolts

Refer to Table 4.2 for torque in pump abnormality and recommended securing bolts. Secure the inlet port flange with all of the boltholes of the size specified in the Inlet Port Flange Standard Reduced diameter shank bolts (R.D.S.B.) listed on Table 4.2 are more reinforced bolts over standard bolts by smoothing the portion to attach flange securing bolts to the respective face at the equipment side. Refer to Figure 4.6 for Shape of R.D.S.B. Secure the base with all 8 screw-holes for legs or all 8 attached legs. Follow "CAUTION" on page 4-9 about legs and bolts for securing the base. Make sure that the recommended securing bolt may be different depending on the method of securing the base.

Table 4.2 Maximum Torque predicted and Recommended securing bolt for inlet port flange

Model of TMP		STP-H803					
Type of flange		VG150		ISO160F		ICF203	
Torque in pump abnormality [Nm]		2.8×10 ⁴		2.8×10 ⁴		2.8×10 ⁴	
Base(8 positions)securing		No	Yes	No	Yes	No	Yes
Recommended securing bolt for TMP Flange	Type of bolt	R.D.S.B.*2	Standard	R.D.S.B.*2	Standard	Standard	Standard
	Type of steel*1	Carbon steel Alloyed steel	Stainless steel	Carbon steel Alloyed steel	Stainless steel	Carbon steel Alloyed steel	Stainless steel
	Strength*1	12.9 or more	70 or more	Equivalent to AMS 6419	70 or more	12.9 or more	70 or more

Model of TMP		STP-H1303					
Type of flange		VG200		ISO200F/ISO200		ICF253/ICF305	
Torque in pump abnormality [Nm]		2.8×10 ⁴		2.3×10 ⁴		2.8×10 ⁴	
Base(8 positions)securing		No	Yes	No	Yes	No	Yes
Recommended securing bolt for TMP Flange	Type of bolt	Standard	Standard	Standard	Standard	Standard	Standard
	Type of steel*1	Stainless steel	Stainless steel	Stainless steel	Stainless steel	Stainless steel	Stainless steel
	Strength*1	70 or more	70 or more	70 or more	70 or more	70 or more	70 or more

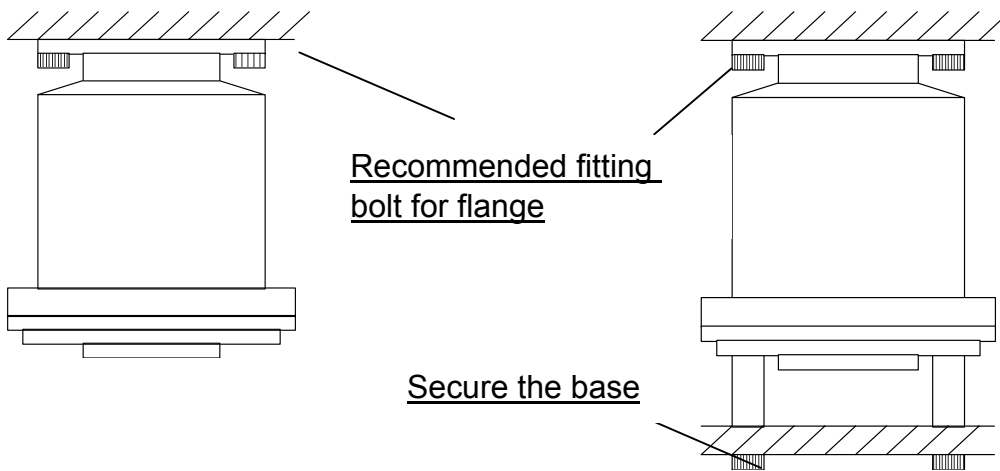

(a) When the base is not secured

(b) When the base is secured

Figure 4.5 Example of securing the STP pump
(When securing the inlet port with bolts)

*1 Refer to ISO898-1(JISB1051), ISO3506(JISB1054) and AMS6419(Aerospace Material Specification)

*2 Refer to Figure 4.6 Shape of Reduced Diameter Shank Bolts(=R.D.S.B.)

Refer to the following Figure for the shape of R.D.S.B.

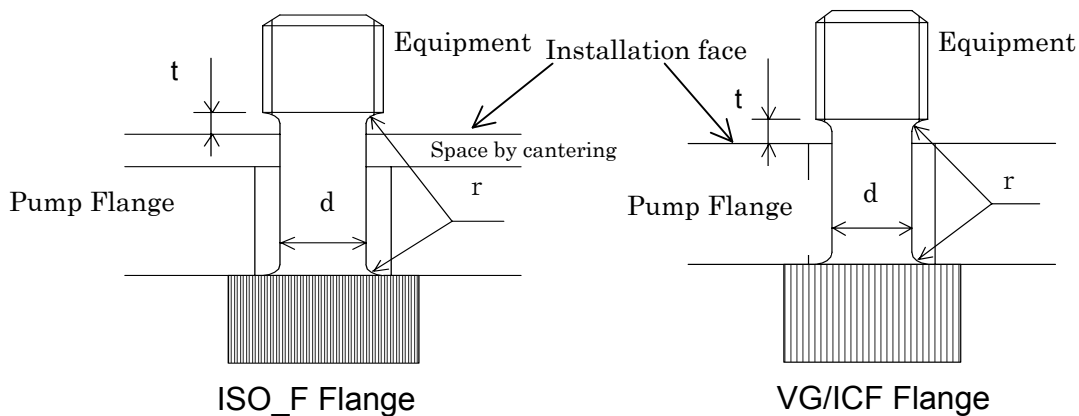

Bolt size	Type of flange	t	d	r
M8	ISO_F flange	2.5 mm or more	5.9 mm or more	0.8 mm or more
	ICF flange	1 mm or more		
M10	ISO_F flange	3 mm or more	7.5 mm or more	
	VG flange	1.5 mm or more		
M12	ISO_F flange	3.5 mm or more	9.1 mm or more	
	VG flange	2 mm or more		

Figure 4.6 Shape of Reduced Diameter Shank Bolts

CAUTION

◆ Be sure to confirm that the surface of the leveled and smoothed area (expressed by "d" in the Figure 4.6) is free of crack, depression, and other damages. Also, when you want to use commercially-available screws, be sure to thoroughly grind them so as not to leave spiral seams on their bottom.

2) When securing the inlet port flange with claw clamps

Refer to Table 4.2 for rotational torque.

When securing the inlet port flange with only the claw clamp, the vacuum equipment cannot withstand the maximum rotational torque generated by the worst-case failure. To make the vacuum equipment withstand abnormal torque, secure the base with all 8 screw-holes for legs or all 8 attached legs. Follow "CAUTION" on page 4-9 about legs and bolts for securing the base.

For the claw clamp-type, use the required number of claw clamps as specified in Table 4.3. Position the claw clamps evenly on the circumference.

Table 4.3 Number of Claw Clamps by Size of Flange

Size of Flange	Number of Claw Clamps
ISO 160 or less	4 or more
ISO 200 to 250	6 or more
ISO 320 or more	8 or more

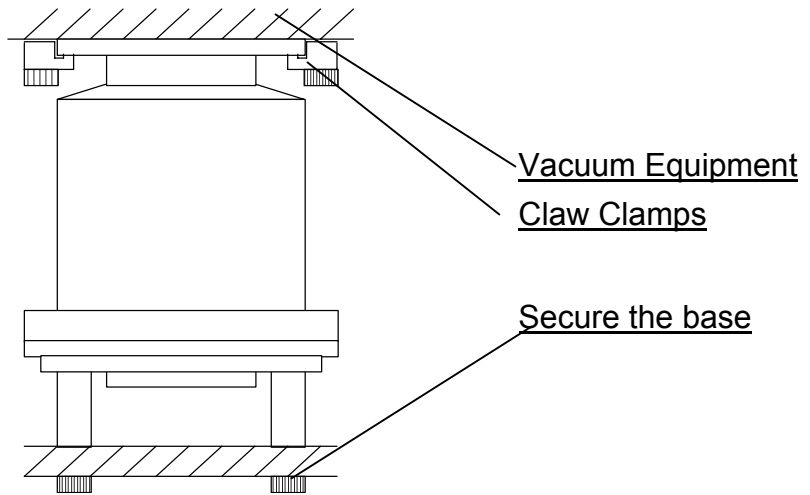
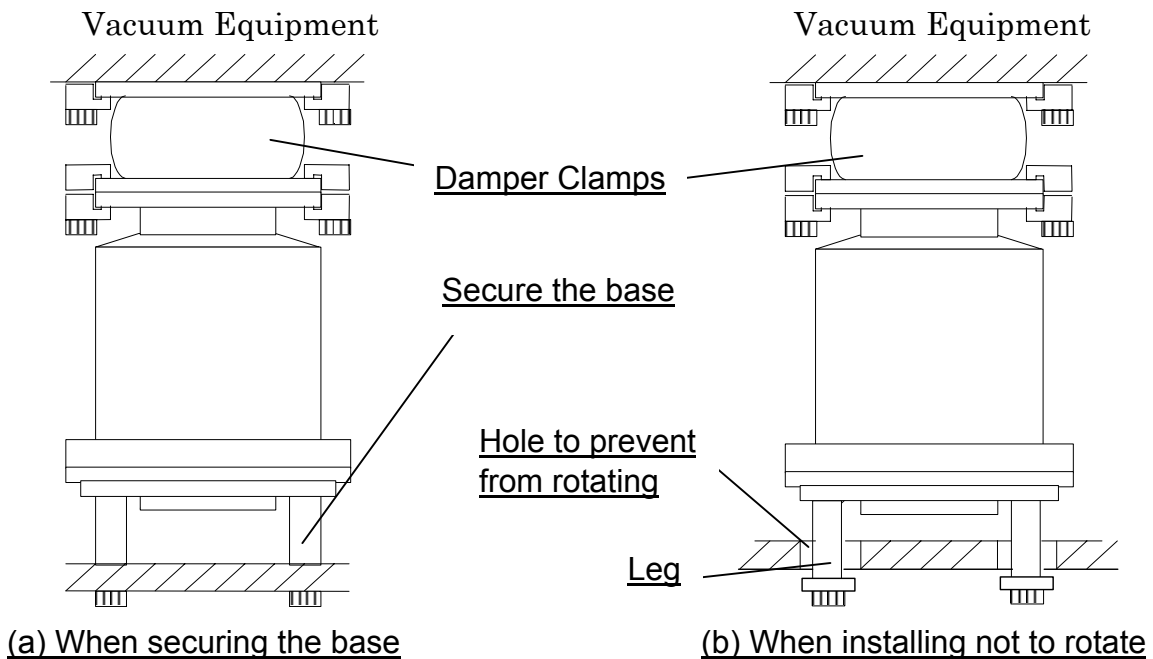

**Figure 4.7 Example of securing the STP pump
(When securing the inlet port flange with claw clamps)**

- 3) When installing the damper in the inlet port flange
 Refer to Table 4.2 for rotational torque.
 In case of using a damper, secure the base with all 8 screw-holes for legs or all 8 attached legs. Follow "CAUTION" on page 4-9 about legs and bolts for securing the base.
 When the base cannot be secured because of the equipment design, install the pump with a torque restraint like the one shown in Figure 4.8 (b).

CAUTION

- ◇ Use a damper only at the vertically upright position.
- ◇ DO NOT remove the bolts and nuts attached to reinforce the damper.



**Figure 4.8 Example of securing the STP pump
(When installing the damper in the inlet port flange)**

4.3.4 Vacuum Piping



- ◇ **DO NOT** open the STP pump through the flange to atmospheric air while the STP pump is running. If atmospheric air flows into the STP pump, it may not function normally.
- ◇ Depending upon the type of the backing pump used, atmospheric air may reverse flow into the STP pump when the backing pump stops. Attach a vacuum valve to the middle of the piping between the STP pump outlet port flange and the backing pump, and close the vacuum valve when the backing pump stops.

In order to let the STP pump bring its performance into full play, follow the precautions below:

- 1) Be careful not to scratch the flange of the STP pump. Before installing the STP pump, check whether or not there are scratches on the surface.
- 2) Use stainless steel or aluminum alloy tubes with a low gas loss to connect the vacuum equipment to the STP pump.
- 3) Take measures for minimizing leakage. It is also necessary to degrease the tubes as regularly as possible to keep the gas loss as low as possible.
- 4) It is recommended to use a backing pump of pumping speed 1300 L/min or more.

However, the pressure at the inlet and outlet ports varies with the flow rate of gas, capacity of the vacuum equipment, length and material of the piping. Select a backing pump in accordance with the capacity and starting method (simultaneous starting, starting after generating roughing vacuum) suitable for the vacuum equipment you use.

- 5) Connect the STP pump and the backing pump using stainless steel or aluminum alloy tubing, flexible tubing, vacuum rubber or Teflon tubing, and other.

The following measures can be used to avoid the transmission of the vibration of the backing pump to the STP pump and the vacuum equipment.

- DO NOT place the backing pump on the same floor as the vacuum equipment.
- Locate the backing pump on a vibration-proof table. Attain 1/3 or less of the rotational speed of the backing pump, when adjusting the inherent frequency of the backing pump installed on a vibration-proof table.
- Attach a weight to the piping from the backing pump, or secure the piping to a rigid, heavy object free of vibration.
- Use a tube of high flexibility.

- 6) Depending upon the type of the backing pump used, oil vapor may contaminate the inside of the STP pump. Some oil viscosity could cause a malfunction when there is a strong reverse flow of oil.

Take the following measures to ensure the correct flow of oil:

- Attach a vacuum valve to the middle of the piping between the STP pump outlet port flange and the backing pump.
- Attach an absorption trap adjacent to the vacuum valve.

Piping at the Inlet Port Flange

Attach the inlet port to the high vacuum side.

Maximum working pressure: 13.3 Pa [0.1 Torr] (for water cooled)

(Pressure at the inlet port flange
applicable continuously)

Piping at the Outlet Port Flange

Attach the outlet port to the inlet port flange of the backing pump (primary side pump).

Allowable backing pressure: 270 Pa [2 Torr] (for water cooled)

(Pressure at the outlet port flange
applicable continuously)



- ◇ **Upper pressure is applicable under the following conditions:**
 - The N₂ or other similar gas is vacuumed.
 - The backing pump (pumping speed: 1,300 L/min) is used.
- ◇ **To attain the ultimate pressure shown in Table 13.1, "Specifications for the STP Pump," set the pressure at the outlet port flange to 1.3 Pa (10⁻² Torr) or less.**

4.3.5 Connecting the Purge Port

When pumping reactive or corrosive gases, introduce a dry N₂ gas or other gas into the STP pump in order to protect the inside of the STP pump.

As shown in Figure 4.9, introduce a dry N₂ gas through the electromagnetic vent valve, needle valve or similar valve (must be prepared by the customer) from the purge port.

For instructions on how to introduce the purge gas, see [Section 5.1, "Gas Pumping."](#)



- ◇ **When not introducing the purge gas, close the purge port with the blank flange (attached at delivery).**

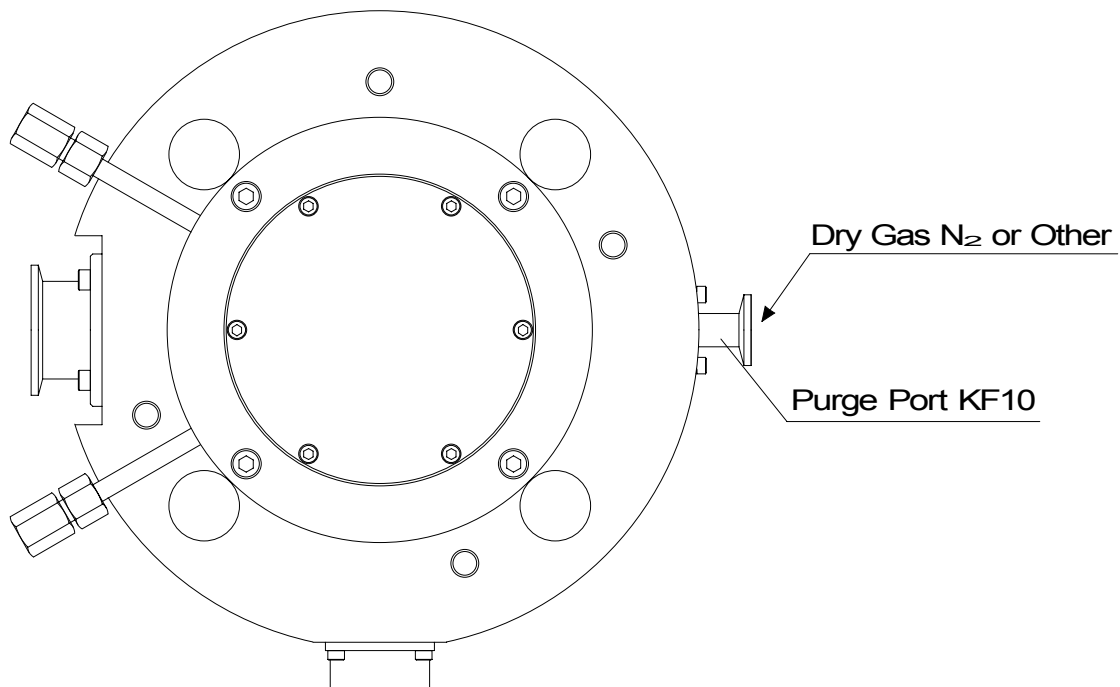

Figure 4.9 Connecting the Purge Port

5 Gas Pumping, Cooling and Baking the STP Pump

5.1 Gas Pumping

WARNING

- ◇ When pumping gases, they may remain in the STP pump. Introduce a purge gas and then exhaust all gasses. Residual gases in the STP pump may cause an accident when the STP pump is removed. Confirm the characteristics of gases to be used, referring to the Material Safety Data Sheet (MSDS) you obtain from the gas supplier.

CAUTION

- ◇ The STP series models are chemical specific pumps; chlorine or fluorine system gases can be used with these models. When you use gases including alkaline metals, but excluding Li, gases including Ga, Hg, In, or Sn, or HBr, contact BOC Edwards.
- ◇ Cool the STP pump to prevent the STP pump from overheating when pumping gases

5.1.1 How to Introduce a Purge Gas

CAUTION

- ◇ When pumping reactive or corrosive gases, introduce a purge gas to protect the inside of the STP pump. Doing so may result in product damage.

Connect a needle valve or a similar part to the purge port and introduce a dry N₂ gas or other gas to perform a gas purge (See [Section 4.3.5, "Connecting the Purge Port"](#)).

NOTICE

- ◇ The proper amount of the gas purge is approx. 3.4×10^{-2} Pa·m³/sec (20SCCM).
- ◇ The allowable gas pressure ranges from zero [atmospheric pressure] to 4.9×10^4 Pa [gauge pressure] (zero [atmospheric pressure] to 0.5 kgf/cm² [gauge pressure]).
- ◇ High-pressure at the inlet port may result in a noise. This is no abnormality/error.

5.2 Cooling the STP Pump

When pumping gases, cool the STP pump.

Also, when performing baking, always cool the STP pump.

If the TMS unit is used, cool the STP pump with the method specified for the TMS unit.

5.2.1 Water Cooling Method

Connect the cooling water pipe to the cooling water port in accordance with Figure 5.1.

The female screw PT (RC)1/4 is used in the cooling water port.

Secure the connection hose to prevent water leakage.

Use cooling water under the following conditions:

Amount of water:	2 L/min
Temperature:	5 to 25 °C
Water pressure:	2.9×10^5 Pa (3 kgf/cm ²) or less.



- ◇ **Use clean water as much as possible.**
Cooling water containing foreign materials may corrode or clog the cooling water pipe.
When the cooling system is clogged with foreign materials, clogs may possibly be removed by feeding cooling water reversibly.
- ◇ **When the STP pump is overheated due to shortage or suspension of water, the protective function detects the overheated condition in the STP pump and stops the STP pump.**
As a further safety procedure, attach a flow switch to the cooling water exit so that the STP pump stops if abnormal cooling water flow occurs (A flow switch is available on the market).
- ◇ **When the STP pump is not to be used for a long period of time or it is to be moved after use, introduce compressed air from one side of the cooling water port so that no water will remain inside.**
- ◇ **The joint for water cooling unit is made of stainless steel.**
To prevent corrosion, connect the stainless steel joint.

5.3 Baking the STP Pump

To attain a less pressure in a shorter time and reduce the exhaust time, bake the vacuum equipment and STP pump.



- ◇ The surfaces of the STP pump and its peripheral equipment will become extremely hot when performing baking. **NEVER** touch them with bare hands.



- ◇ The TMS unit and the baking heater cannot be used together at the same time.
- ◇ When baking the STP pump, always cool it to prevent overheating.
- ◇ Start baking after cooling is started.
Set the temperature of the baking heater to 120 °C or less.
- ◇ **DO NOT** pump gases during baking to prevent overheating.



- ◇ To exhaust the gas discharged from the vacuum equipment and the inner wall of the STP pump, run the STP pump during baking.

5.3.1 Attaching a Baking Heater

- 1) Install the backing heater (special accessory) near the inlet port flange in the perimeter of the envelope.
- 2) Affix the hot surface warning label attached on the surface of the pump seen well. (See Figure 5.1, "Attaching Positions of the Cooling Unit and Backing Heater")



- ◇ Check the rated voltage of the baking heater before use. (The range of the available voltage of the backing heater (special accessory) is display voltage $\pm 10\%$.)
- ◇ Wind the baking heater around the surface of the STP pump tightly. If the baking heater is not wound tightly, the loose parts will overheat.
- ◇ Procure protective parts for the baking heater, such as an earth leakage breaker or fuses when using the baking heater.
- ◇ **DO NOT** apply excessive force to the cable for the baking heater.

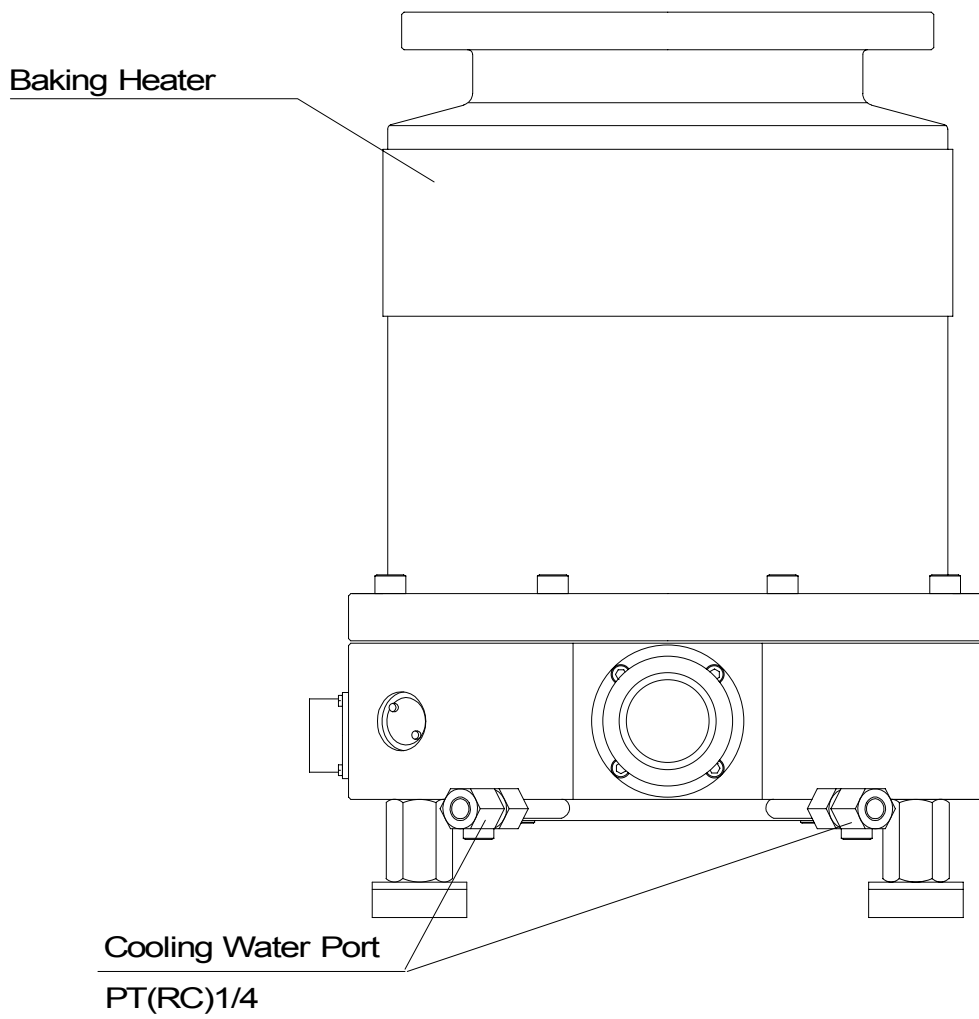

Figure 5.1 Attaching Positions of the Cooling Unit and Baking Heater

6 Installation of the STP Control Unit

6.1 Name and Function of Each Part

6.1.1 Front Panel

- (1) "START" Switch (flat panel switch, green)
 - STP pump rotating function (valid in MANUAL operation only).
- (2) "STOP" Switch (flat panel switch, dark gray)
 - STP pump stop operation function (valid in MANUAL operation only).
- (3) "RESET" Switch (flat panel switch, gray)
 - Alarm reset function (valid in MANUAL operation only).
 - Tuning function (valid in both MANUAL and REMOTE operation).
- (4) "MANUAL/REMOTE" Changeover Switch (slide switch, black)
 - Operation mode changeover function.
- (5) "SELECT" Switch (flat panel switch, gray)
 - LCD display (Confirmation mode change) function (valid in both MANUAL and REMOTE operations).
 - Setting mode change function (valid in both MANUAL and REMOTE operations).
Press both of "SELECT" and "UP" switches simultaneously to enter the setting mode.
- (6) "UP" Switch (flat panel switch, gray)
- (7) "DOWN" Switch (flat panel switch, gray)
 - Abnormality/error display change function (valid in both MANUAL and REMOTE operations).
 - Setting content confirmation function (valid in both MANUAL and REMOTE operations).
 - Setting content change function (valid in both MANUAL and REMOTE operations).
- (8) "ENTER" Switch (flat panel switch, gray)
 - Setting content determination function (valid in both MANUAL and REMOTE operations).
 - WARNING message display function (valid in both MANUAL and REMOTE operations).

- (9) LCD
- The LCD displays a pump's operation state, speed, or other messages.
 - The LCD displays an error message when an abnormality/error occurs in the STP pump.
- (10) "ACCEL." Lamp (green LED)
- Lights during acceleration (ACCELERATION state).
- (11) "NORMAL" Lamp (green LED)
- Lights during rated speed operation (NORMAL OPERATION state).
- (12) "BRAKE" Lamp (green LED)
- Lights during deceleration (BRAKE state).
- (13) "POWER" Lamp (green LED)
- Lights while the power is ON.
 - Goes out while the backup power is being supplied.
- (14) "FAILURE" Lamp (red LED)
- Lights when any of the abnormalities/errors occurs on the STP pump and the STP control unit. The LCD displays an error message simultaneously.
- (15) "REMOTE" Lamp (green LED)
- Lights while the operation mode is remote.
- (16) "TEMP CTRL" Lamp (green LED)
- Lights while the TMS unit (optional accessory) is in operation.

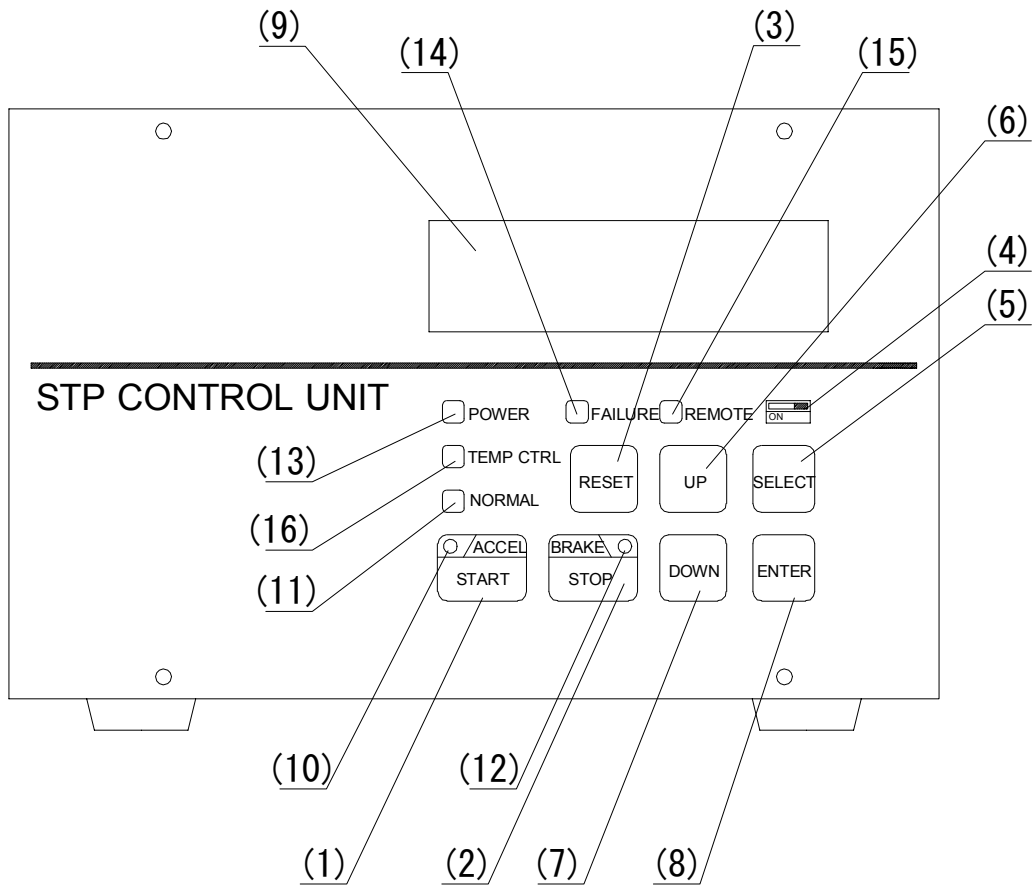

Figure 6.1 STP Control Unit Front Panel

6.1.2 Rear Panel



- ◇ A hazardous live voltage may exist at connector that marked



DO NOT touch the terminal. Doing so may result in electric shock. When operating connection/disconnection to connector, always power OFF the STP pump (Switch the breaker "OFF").

(17) AC POWER Connector (X2)

A maximum voltage : Equal to the input voltage of this connector. (MAX 240VAC)

- For primary power input.

(18) MAIN POWER Breaker

- Switches ON/OFF the primary power.

(19) P.CONNECTOR Connector (X1)

A maximum voltage: 79VAC

- For connection of the STP connection cable.

(20) REMOTE Connector (X7)

A maximum voltage: Equal to the input voltage of this connector. (MAX 125VAC)

- For the remote operation.

(21) TMS Connector (X5)

A maximum voltage: Equal to the input voltage of "AC POWER" connector. (MAX 240VAC)

- For the connection of the TMS unit (optional accessory).

(22) Ground Terminal

- For connection of the ground.

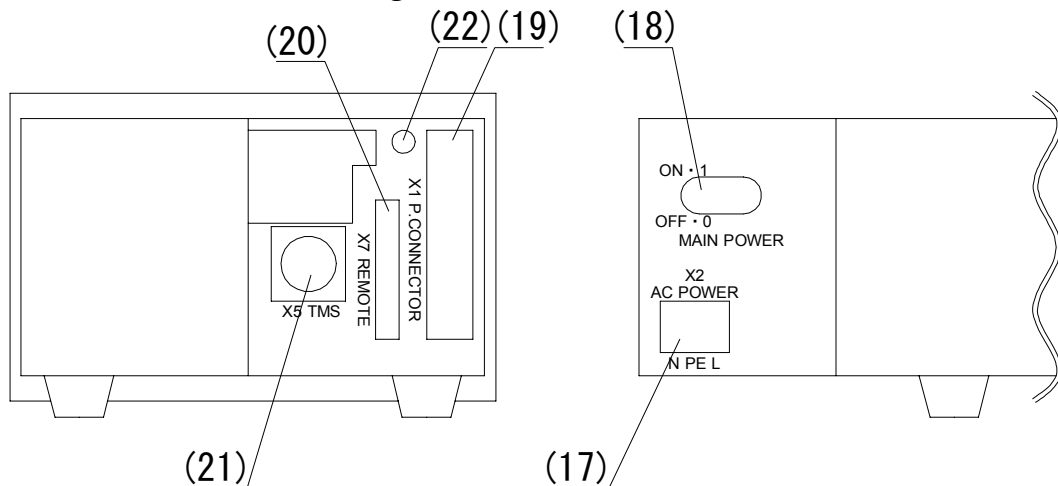

Figure 6.2 STP Control Unit Rear Panel

6.2 Precautions Before Installation

6.2.1 Operating Environment

Install the STP control unit in a place meeting the following requirements:

Ambient Temperature	0 to 40 °C
Ambient Relative Humidity	30 to 95% (no dew condensing)
Environment	<ul style="list-style-type: none"> • A place free of exposure to direct sunlight. • A place free of high humidity. • A place free of dust. • A place free of salty air. • A place free of dripping water. • A place free of explosive or inflammable gas. • A place free of corrosive gas. • A place free of radiation. • A place free of strong magnetic and electric fields. • A place free of excessive vibration. • A place free of a source of electric noise.
Installation Condition	<ul style="list-style-type: none"> • Install the STP control unit horizontally (within $\pm 10^{\circ}\text{C}$).

6.2.2 Insulation Test

Do not perform the insulation test (insulation resistance test and withstand voltage test) to the STP control unit.

When performing the insulation test to your equipment, turn "OFF" the STP control unit so that the test voltage is not applied to the STP control unit.



- ◇ **The varistor for the power supply line protection is installed to the STP control unit.
DO NOT perform the insulation test with the varistor installed.
Doing so may result in product damage.**

6.2.3 Installation Area

Leave enough space for the following in addition to that for the STP control unit

- Space for maintenance and inspection
- Space for inlet and outlet of air for cooling
 - Top and side: 5 cm or more
 - Bottom: 1.8 cm or more (height of the rubber feet)
- Space for connecting the cables
 - Rear: 11.5 cm or more



- ◇ **The minimum bending radius of the STP connection cable is 100 mm (See Section 13, "External Appearance of the STP Control Unit" [Cable Space]).**
DO NOT excessively bend the cables and beware of any obstacles when installing the STP pump.
Also, leave enough space to install other cables without bending them excessively.

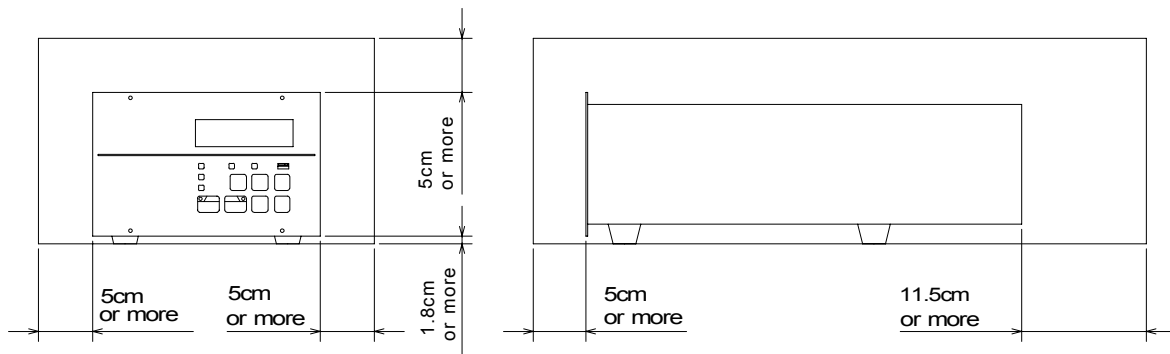

Figure 6.3 Peripheral Space of the STP Control Unit

6.3 Attaching the STP Control Unit to a Rack

The dimensions of the STP control unit front panel conform to EIA standard. Therefore, this panel can be attached to any type of commercially-available racks. Attach the STP control unit to the rack according to the following steps:

- Attach the front panel to a rack using the screw holes for the front panel.
- Also support the STP control unit from the bottom using a support angle or a similar tool.
- When attaching the STP control unit to a movable rack, to protect the STP control unit during transport, remove the rubber foot from the bottom and attach the STP control unit to the rack using the screw holes for the rubber foot.

CAUTION

- ◇ **The STP control unit cannot be supported with only the screws on the front panel (The STP control unit is a heavy product). Always support it from the bottom.**
- ◇ **When installing the STP control unit, DO NOT block the ventilation port of the STP control unit by the support angle or other things. It causes the control unit to overheat.**

NOTICE

- ◇ **For the dimensions of the front panel and positions of screw holes for the rubber feet, see Figure 13.4, "External Appearance of the STP Control Unit."**

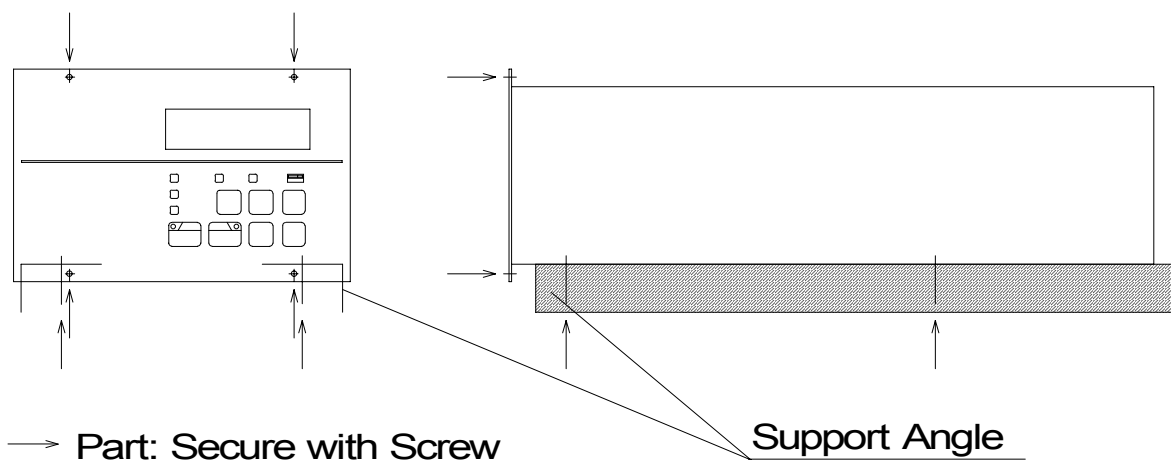

Figure 6.4 Example of Securing the STP Control Unit

6.4 Cable Connection

6.4.1 Name and Dimensions of Each Cable

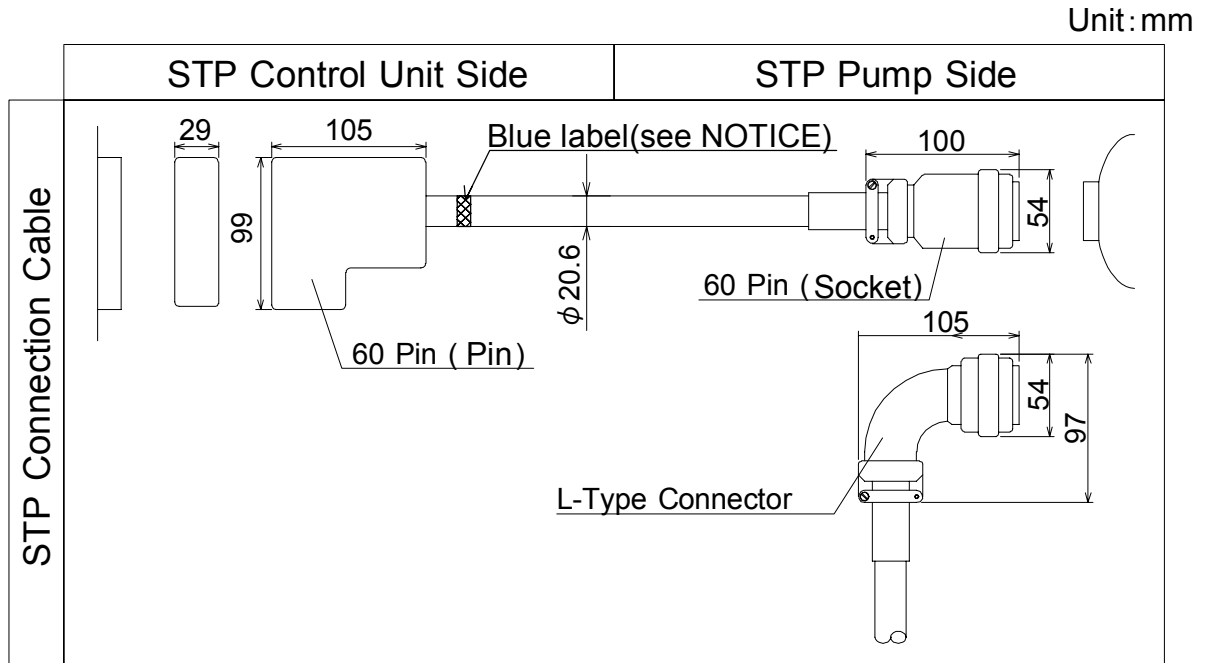
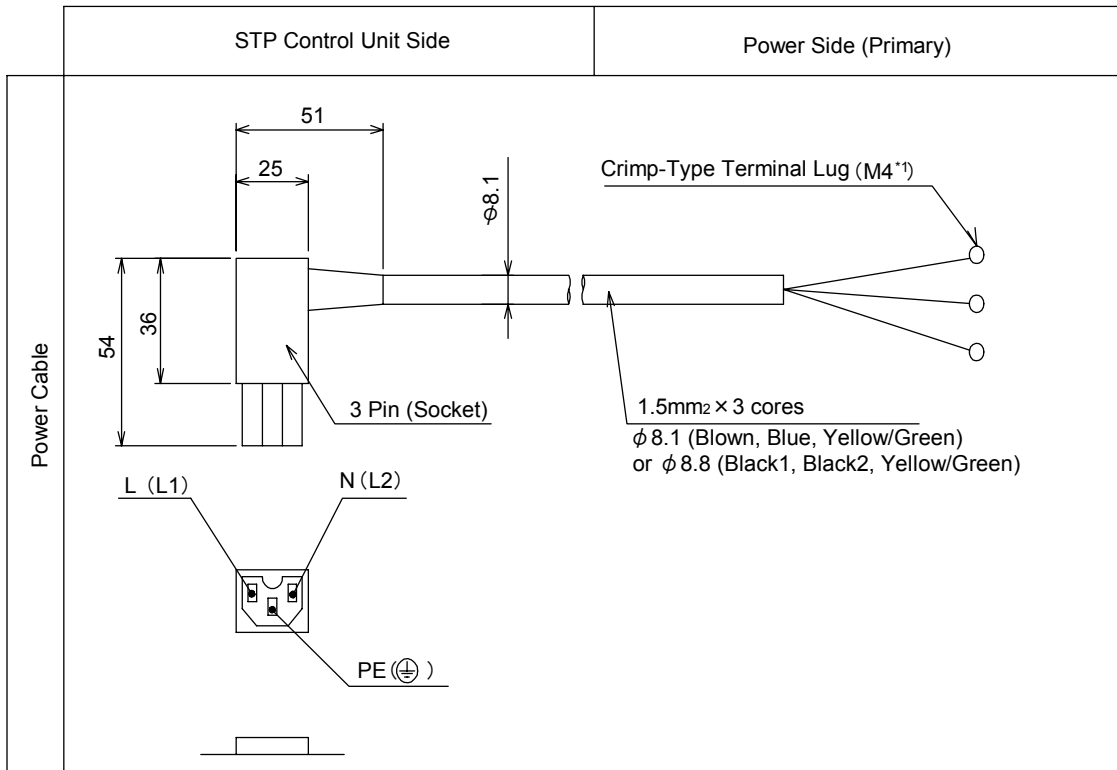

Figure 6.5 External Dimensions of Each Cable



- ◇ There are two types of STP connection cables. These cables can be distinguished by a blue label.
This series pump can use either STP connection cable.

Unit: mm



a) without power plug

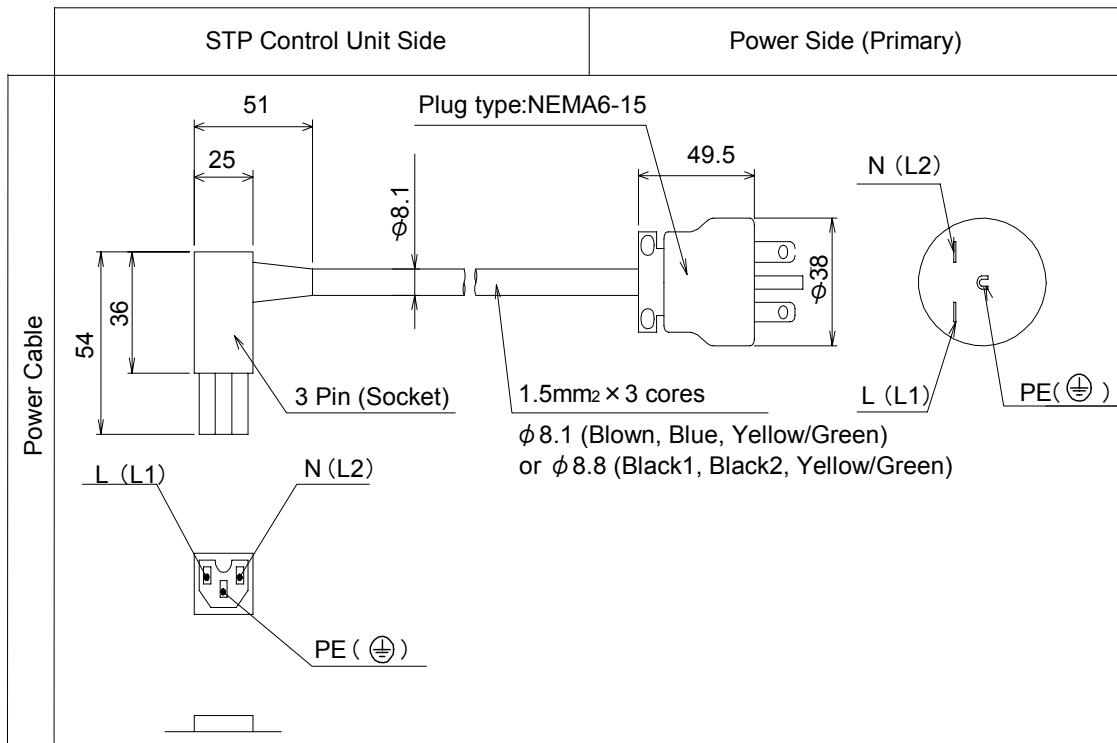

b) with power plug

Figure 6.6 External Dimensions of Each Cable

^{*1}: JIS

6.4.2 How to Connect the Cables



- ◇ Use the STP connection cable that BOC Edwards has specified. The use of other cables may result in product damage.
- ◇ When connecting/disconnecting cables, always power OFF the STP pump (Switch the breaker "OFF"). Failure to do so may result in electric shock or product damage.
- ◇ With each connector, align the position of the guide key and insert the pin vertically so as not to bend it. If the pin is bent, not only may the connector not function normally, but may make the pins contact, resulting in a malfunction.
- ◇ Lock and securely tighten each connector and screw.
- ◇ DO NOT apply voltage to each pin and DO NOT cause any short-circuiting between pins.
- ◇ Connect each cable securely. DO NOT place heavy objects on the cables nor bend them excessively. Support each cable so as not to apply direct force to the connectors or terminals. If any problem occurs in cables, connectors or terminals, the STP pump may not function normally.

(1) Connecting the STP Connection Cable

Connect the receptacle (socket) side of the STP connection cable to the STP connector of the STP pump and connect the plug (pin) side to "P.CONNECTOR X1" of the STP control unit.

(2) Connecting the TMS Connection Cable (for Use with the TMS unit only)

Connect the plug (pin) side of the TMS connection cable to the "TMS X5" of the TMS control unit.

(3) Connecting the Power (Primary Side) Cable

Connect the power cable to the "AC POWER X2" on the STP control unit rear panel as shown in Table 6.1.

Table 6.1 Connecting the Power Cable

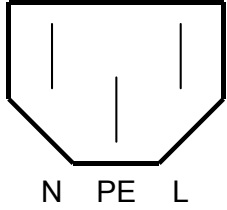
CON1 Pin No.	Cable Color	Remarks	Rear Panel "AC POWER" Outline of Connector
L(L1)	Brown or Black1	Single phase 200 to 240 V AC $\pm 10\%$ Both 50/60 Hz	
N(L2)	Blue or Black2		
PE(\oplus)	Yellow/Green	Ground	

CAUTION

- ◇ Confirm the power voltage on the name plate.
- ◇ Connect the power cable securely to prevent incorrect wiring.
- ◇ DO NOT apply surge voltage exceeding 1 kV to the input power line.
- ◇ Always ground the power cable to prevent electric shock.

6.5 Connecting to Semiconductor Equipment

The STP pump is a component system when installing to the semiconductor equipment.

Consider the followings when designing the semiconductor equipment.

6.5.1 Connecting to Power

The STP control unit receives its power from the semiconductor equipment electrical distribution system via a circuit breaker.

Electrical energy isolation (Lockout/Tagout) is achieved by opening the main disconnect device or circuit breaker of the semiconductor equipment, thereby: removing power from the STP pump.

Provide the equipment with the main disconnect or circuit breaker devices rated for at least 10,000 A_{rms} symmetrical amperes interrupting capacity (AIC).

6.5.2 Emergency Off Circuit (EMO Circuit)

Activation of EMO circuit of the equipment will interrupt electrical power from the STP control unit.

When the power is shut off, the STP pump performs the same as a power failure. (After backup operation of a power failure, the rotor lands on the touch down bearing)

Consider the followings when establishing the EMO circuit.



- ◇ **Unite the exhaust gas system to prevent atmosphere from being introduced into the STP pump when the EMO circuit operates. (example: shut the valve) When atmosphere is introduced into the STP pump, the touch down bearing may not operate normally.**
- ◇ **The STP pump rotates for a while after the EMO circuit shuts off the power. Perform a recovery operation after the STP pump has stopped completely.**
- ◇ **Before performing the operation check of the EMO circuit with regular maintenance, stop the STP pump to prevent damage to the touch down bearing.**

7 How to Start/Stop the STP Pump



- ◇ **NEVER** connect or disconnect any cables while the power is **ON**.
- ◇ **NEVER** turn the primary power **OFF** (Switch the breaker "OFF") while the STP pump is in rotation.
- ◇ **DO NOT** release the inlet port flange or outlet port flange into the atmosphere while the STP pump is in rotation.

7.1 Before Starting

After completing installation, piping, leakage test of the STP pump, installation of the STP control unit, and wiring of cables, the STP pump is ready for start. Check the following items before starting:

- 1) Are the STP pump and the STP control unit secured according to the appropriate method?
- 2) Is the power cable connected correctly to the power supply?
- 3) Is the power voltage selected properly?
- 4) Are the STP connection cable, and other cables securely connected?
Are each terminal and each connector securely locked?
- 5) Is the serial number of the STP pump the same as that of the STP control unit?
If they are different, perform the tuning according to Section 9.1, "Tuning."
- 6) Did you change the STP connection cable length? If you did, perform the tuning by reference to Section 9.1, "Tuning."

7.2 Start Procedures

Start the backing pump before or simultaneously with start of the STP pump. Open the vacuum valve located at the outlet port flange side after starting the backing pump.



- ◇ **DO NOT** open the vacuum valve without operating the backing pump. Depending upon the type of the backing pump, doing so may cause a reverse flow of oil, which could contaminate the inside of the STP pump.
- ◇ **When start/stop operations are frequently performed, the STP pump may overheat. Avoid doing so.**

7.3 Stop Procedures

Close the vacuum valve located at the outlet port flange side just before or after stopping the STP pump.
After closing the valve, stop the backing pump.



- ◇ **DO NOT** stop the backing pump without closing the vacuum valve. Depending upon the type of the backing pump, doing so could cause a reverse flow of atmospheric air into the STP pump, which may result in a malfunction.



- ◇ **DO NOT** stop the backing pump without closing the valve. Depending upon the type of the backing pump, doing so may cause a reverse flow of oil, which could contaminate the inside of the STP pump.

There are two methods of operating the STP pump: MANUAL and REMOTE.

Select one which fits your vacuum equipment.

7.4 Manual Operation

(See Table 7.1)

Slide the "MANUAL/REMOTE" changeover switch on the STP control unit front panel to the position opposite to "ON." At this time, the "REMOTE" lamp is off.

7.4.1 Powering ON

- 1) Switch "ON" the breaker on the rear panel. (To prevent incorrect operation, a metal fitting is attached to the breaker. Loosen the screw, lift the metal fitting, and secure it.)
The magnetic bearing functions and the rotor levitates (POWER ON state).
The "POWER" lamp lights.
- 2) The STP control unit executes the self test. If no error is found, the LCD displays "Levitation".
In case of the STP pump with the TMS unit (optional accessory), the "TEMP CTRL" lamp also lights and the TMS unit starts.

7.4.2 Starting the STP Pump

- 1) Press the "START" switch on the front panel to start and accelerate the STP pump. The "ACCEL." lamp lights. The LCD displays the current rotational speed in "ACCEL: ***00rpm" in units of 500 rpm (ACCELERATION state).



- ◇ **Until "ACCEL: 500 rpm" is displayed, "ACCEL: \curvearrowright rpm" is displayed for Approx. 1 minute on the LCD.**
- 2) When the STP pump attains the rated speed of rotations, the "ACCEL." lamp goes out, and the "NORMAL" lamp lights. Also, the LCD displays "NORMAL: ***00rpm" (NORMAL OPERATION state).

7.4.3 Stopping the STP Pump

- 1) Press the "STOP" switch on the front panel to stop the STP pump. The "NORMAL" lamp or "ACCEL." lamp goes out, and the "BRAKE" lamp lights (BRAKE state).
- 2) The "BRAKE" lamp goes out when the rotational speed goes below 500 rpm.

7.4.4 Starting the STP Pump after Stopping

Press the "START" switch on the front panel to reaccelerate the STP pump. The STP pump can be reaccelerated even while it is stopping.

7.4.5 Powering OFF

Switch "OFF" the breaker on the rear panel when all three lamps of "ACCEL.", "NORMAL," and "BRAKE" are off.

The magnetic bearing stops, the rotor lands, and the "POWER" lamp goes out (POWER OFF state).

In case of the STP pump with the TMS unit (optional accessory), the "TEMP CTRL" lamp also goes out and the TMS unit stops.

7.4.6 Starting the STP Pump after a Safety Function Operates

A safety function operates when an abnormality/error occurs in the STP pump or peripheral equipment. To restart the STP pump, remove the cause of the abnormality/error after the "BRAKE" lamp goes out, and press the "RESET" switch. The "FAILURE" lamp goes out and the safety function is released (RESET operation). Then, press the "START" switch.

For the safety functions and troubleshooting, see Section 11, "Troubleshooting, Maintenance, and Inspections."

7.5 Remote Operation

(See Figures 7.1.)

(Read through Section 8, "Remote Input/Output Signal Connector" before use.)

Slide the "MANUAL/REMOTE" changeover switch on the STP control unit front panel to "ON." The "REMOTE" lamp lights.

7.5.1 Powering ON

- 1) Switch "ON" the breaker on the STP control unit rear panel. (To prevent incorrect operation, a metal fitting is attached to the breaker. Loosen the screw, lift the metal fitting, and secure it.)
The magnetic bearing functions and the rotor levitates (POWER ON state).
The "POWER" lamp lights.
- 2) The STP control unit executes the self test. If no error is found, the LCD displays "Levitation".
In case of the STP pump with the TMS unit (optional accessory), the "TEMP CTRL" lamp also lights and the TMS unit starts.

7.5.2 Starting/Stopping the STP Pump

There are two methods of starting/stopping the STP pump. Use one of them.

Table 7.1 Starting/Stopping the STP Pump during Remote Operation
(REMOTE X7)

Method	Starting the Pump	Stopping the Pump
1	1) Short the circuit between <u>(1)-(21)</u> . 2) Short the circuit between <u>(3)-(21)</u> for 0.3 seconds or more. However, when inputting this signal simultaneously with switching "ON" the breaker on the rear panel, short the circuit between <u>(3)-(21)</u> for 10 seconds or more.	Open the circuit between <u>(1)-(21)</u> .
2	Short the circuit between <u>(1)-(3)</u> . In this case, (21) is not used.	Open the circuit between <u>(1)-(3)</u> .

7.5.3 Starting the STP Pump after Stopping

Perform the start operation to reaccelerate the STP pump. See Section 7.5.2, "Starting/Stopping the STP Pump."

The STP pump can be reaccelerated even while it is stopping.

7.5.4 Powering OFF

Switch "OFF" the breaker on the rear panel when all three lamps of "ACCEL.", "NORMAL", and "BRAKE" are off.

The magnetic bearing stops, the rotor lands, and the "POWER" lamp goes out (POWER OFF state).

In case of the STP pump with the TMS unit (optional accessory), the "TEMP CTRL" lamp also goes out and the TMS unit stops.

7.5.5 Starting the STP Pump after a Safety Function Operates

A safety function operates when an abnormality/error occurs in the STP pump or peripheral equipment. To restart the STP pump, remove the cause of the abnormality/error after the "BRAKE" lamp goes out, and perform the operation shown in Table 7.2. The "FAILURE" lamp goes out and the safety function is released (RESET operation). Then, restart the STP pump.

For the safety functions and troubleshooting, see Section 11, "Troubleshooting, Maintenance, and Inspections."

Table 7.2 Reset Operation during Remote Operation (REMOTE X7)

Method	Reset Operation
1	Short the circuit between <u>(1)-(22)</u> for 0.3 seconds or more.

7.6 Operating the TMS Unit (For use with the TMS unit only)

7.6.1 Starting/Stopping

Power on the STP pump to automatically start the TMS unit.

Power off the STP pump to automatically stop the TMS unit.

While the TMS unit is in operation, the "TEMP CTRL" lamp of the STP control unit lights.

When the STP pump is in the power ON state, the TMS unit operates regardless of the status of the STP control unit. When the STP pump is the malfunction, the TMS unit is stopped.

7.6.2 Temperature Control

- When the temperature of the STP pump base is lower than the setting value, the TMS heater is turned "ON", and the cooling water value is turned "OFF" to heat the STP pump.
- When the temperature of the STP pump base is higher than the setting value, the TMS heater is turned "OFF", and the cooling water value is turned "ON" to cool the STP pump.

The LCD displays the actual temperature of the STP pump base as "TMS TEMP:**°C."

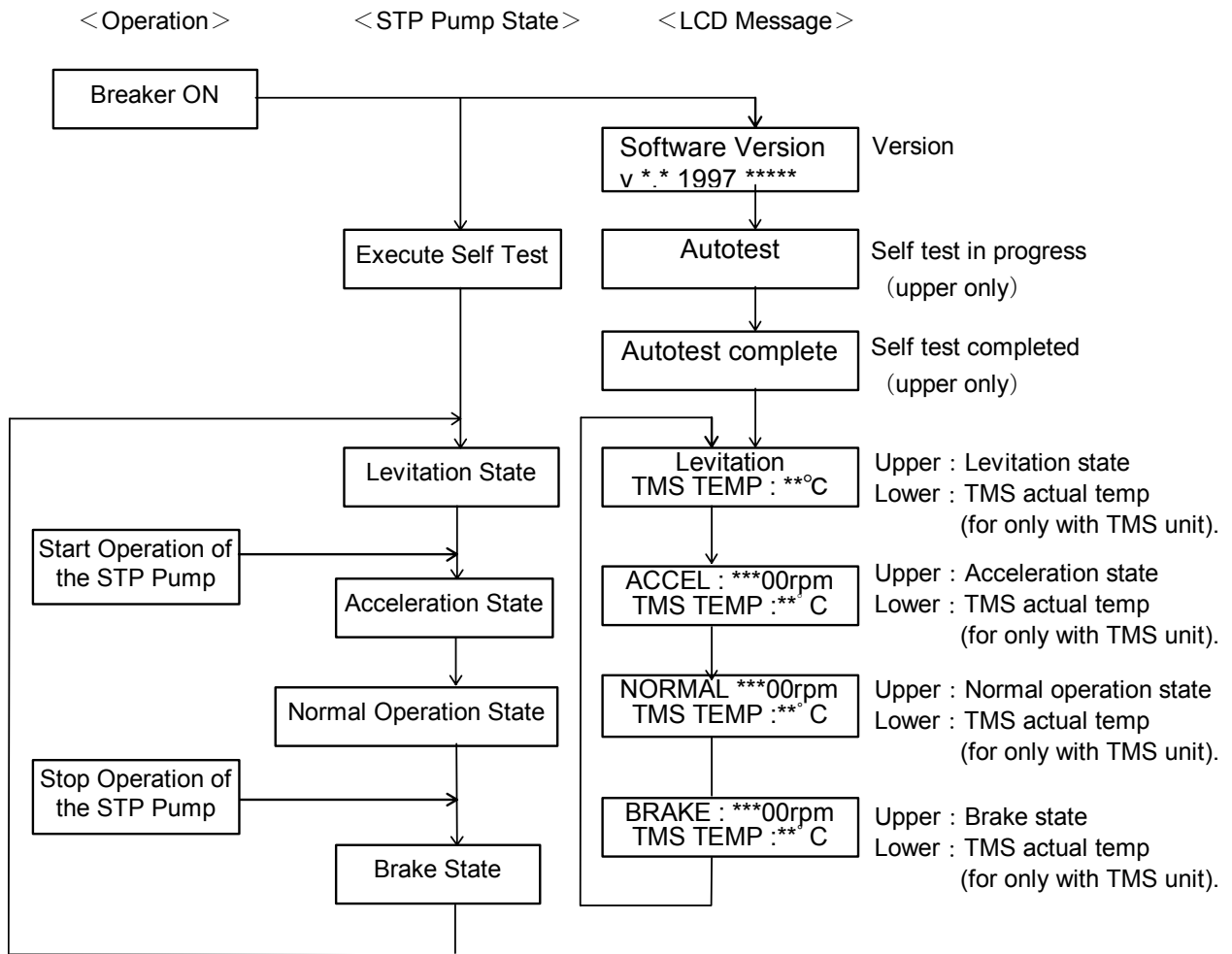

Figure 7.1 STP Pump Operation Procedures

Operation

8 Remote Input/Output Signal Connector

The remote input/output signal connector (REMOTE X7) is used for input/output remote signals.

This connector is of D-Sub*¹ type (37-pins, socket type).

The screw for connector is M2.6*².

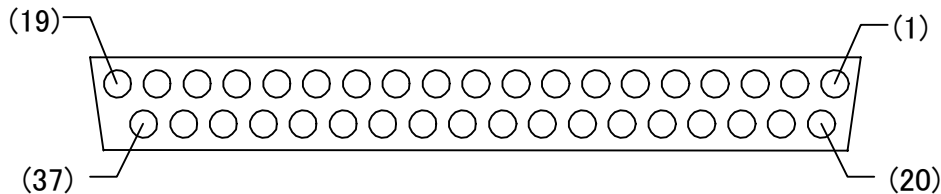

REMOTE X7 Pin Arrangement



- ◇ Procure the connector for remote connection at your company.

8.1 Input Signal Pins

Use input signal pins according to Table 8.1 and Figure 8.1.

Remote input signals function during REMOTE operation only, except the ROTATION INHIBIT signal is input.



Two abbreviations are used in Table 8.1:

COM: Common IN: Input Pin

*1 : D-Subminiature connector (Conforms to MIL-C-24308)

*2 : JIS

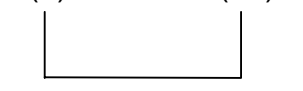
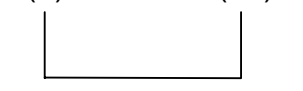
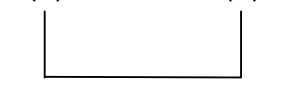
Table 8.1 REMOTE X7 Input Signal Pins

Pin	Description
<p>(1) (3)</p>  <p>COM START IN</p>	<p>Pins for inputting the START signal. The following two methods are available:</p> <ol style="list-style-type: none"> 1) Short the circuits between (1)-(21). Then, short the circuits between (3)-(21) for 0.3 seconds or more. However, when inputting this START signal simultaneously with switching "ON" the breaker on the rear panel, continue to short these pins for 10 seconds or more. 2) Short the circuits between (1)-(3). In this case, (21) is not used.
<p>(1) (21)</p>  <p>COM STOP IN</p>	<p>Pins for inputting the STOP signal.</p> <ol style="list-style-type: none"> 1) When 1) above is used to start the STP pump, open the circuits between (1)-(21) to stop the STP pump. 2) When 2) above is used to start the STP pump, open the circuits between (1)-(3) to stop the pump.
<p>(1) (22)</p>  <p>COM RESET IN</p>	<p>Pins for inputting the abnormality RESET signal. Short the circuits between (1)-(22) for 0.3 seconds or more to turn off the "FAILURE" lamp.</p>
<p>(1) (5)</p>  <p>COM INHIBIT</p>	<p>Pins for inputting the rotation INHIBIT signal (valid in both MANUAL and REMOTE operations). When pins (1)-(5) are set to open, the STP pump does not rotate even by performing the start operation. When these pins are set to open when the pump is in rotation, the pump will stop (The pump does not rotate even by manually starting the pump). When not using this function, set the rotation INHIBIT signal function to the "DISABLE" (See Section 9.3, "Setting Mode").</p>
<p>(2), (4), (6), (18), (19), (20), (23), (24), (31), (34), (36), (37)</p>	<p>These pins are not used.</p> <div style="display: flex; align-items: center;">  <p>◇ DO NOT connect anything to these pins. Doing so may damage the STP control unit or the vacuum equipment.</p> </div>

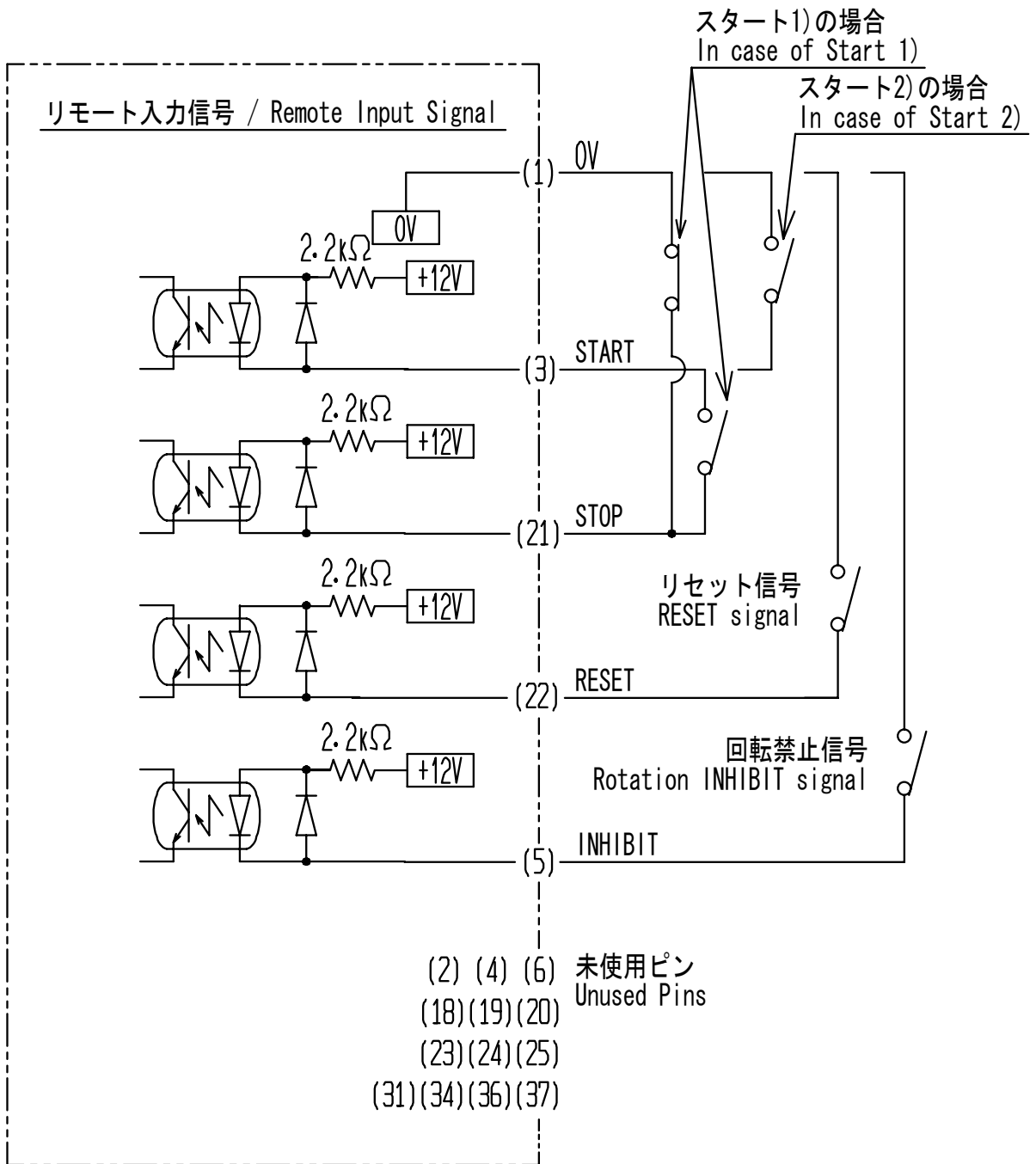

Operation

Figure 8.1 REMOTE X7 Input Signal Pins

NOTICE

- ◇ 1 pin (0V) is insulated from the frame ground.
- ◇ The input current of remote input signal is approx. 5mA. Make sure the minimum applicable load of the relay contact when the remote operation with the relay.

8.2 Output Signal Pins

Use output signal pins according to Table 8.2 and Figure 8.2.

Remote output signals function during MANUAL and REMOTE operations.

Four abbreviations are used in Table 8.2:

N.O: Normal Open N.C: Normal Close
 COM: Common OUT: Output Pin

Table 8.2 REMOTE X7 Output Signal Pins(1/2)



Pin	Description
(8) REMOTE (27) N.O OUT 	Pins for outputting the STP pump REMOTE SELECTION state signal. When the MANUAL/REMOTE changeover switch on the front panel is set to ON (remote side), these pins are closed ("REMOTE" operation).
(9) POWER (28) N.O OUT 	Pins for outputting the POWER ON state signal. These pins are closed when the magnetic bearing functions and the rotor levitates. This output is cut OFF at a power failure.
(10) ACCELERATION (29) N.O OUT 	Pins for outputting the ACCELERATION state signal. These pins are closed when the STP pump is in acceleration.
(11) NORMAL OUT N.O (12) N.C COM (30) 	Pins for outputting the NORMAL OPERATION state signal. When the STP pump is in rated operation, the pins between (11)-(30) are closed, and the pins between (12)-(30) are opened.
(13) BRAKE (32) N.O OUT 	Pins for outputting the BRAKE state signal. These pins are closed when the STP pump is in brake.
(14) ALARM OUT N.O (15) N.C COM (33) 	Pins for outputting the ALARM signal. When an abnormality/error is detected under the POWER ON state, the pins between (14)-(33) are closed, and the pins between (15)-(33) are opened.

Table 8.2 REMOTE X7 Output Signal Pins(2/2)

Pin	Description
	<p>Pins for the TMS unit rated state signal output. When the actual temperature of the TMS unit is within the setting temperature range $\pm 10^{\circ}\text{C}$, the pins between (17)-(16) are closed and the pins between (17)-(35) are opened.</p> <p>If the TMS unit function is not valid, the pins do not function.</p>
	<p>Pins for the emergency vent. valve operation signal. These pins are closed while this valve functions.</p> <p>NOTICE  The emergency vent. valve is not used in this specification. DO NOT use these pins.</p>

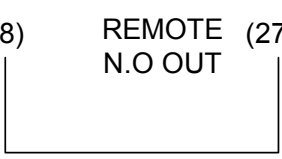
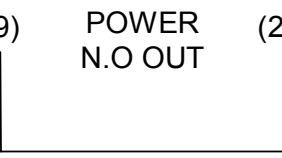
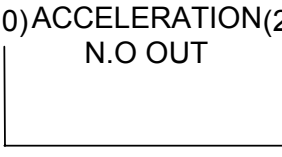
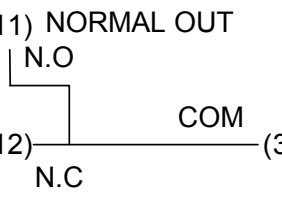
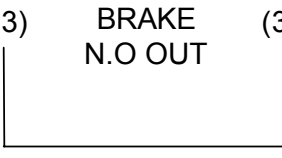
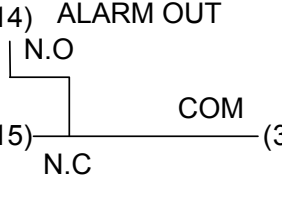
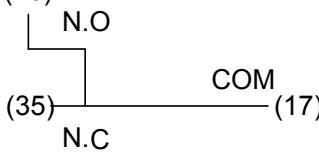
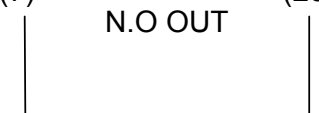
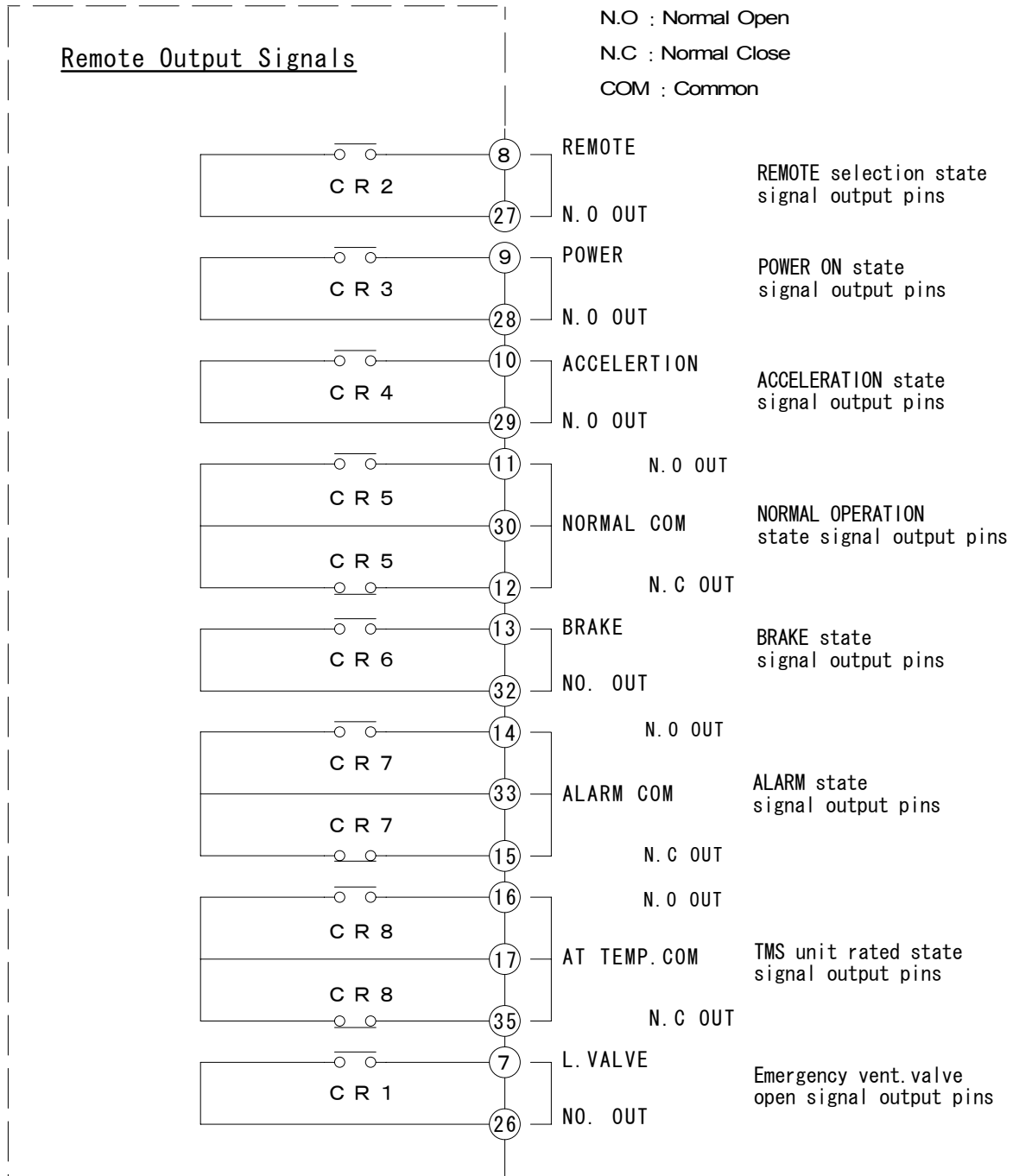

Figure 8.2 REMOTE X7 Output Signal Pins

Table 8.3 shows the rated contacts for relays CR1 to 8 in Figure 8.2.

Table 8.3 Rated Contacts for Relays CR1 to CR8

	Resistance Load ($\text{COS } \phi = 1$)
Rated Load	125V AC 0.5A 24V DC 1A
Rated Current	2A
Maximum Contact Point Current	1A
Maximum Open/Close Capacity	AC: 62.5 VA DC: 30W
Minimum Applicable Load	5V DC 1mA

9 Adjustment Methods

9.1 Tuning

For the STP pump, tuning is required to align the position of levitation in the axial direction with the center of the rotor's movable range.

Tuning can be performed simply by pressing the "RESET" switch on the front panel.

Tuning is completed before delivery, so it is not required before use. However, re-tuning is required in the following cases in which the position of levitation may deviate from the center of the rotor's movable range:

- ◇ **When changing the length of the STP connection cable (not when changing the length of the power cable).**
- ◇ **When changing the combination of the STP pump and the STP control unit (The error message "CAUTION: Bad EEPROM content" is displayed upon performing the self test).**

9.1.1 Tuning Method

- 1) Connect each cable.
- 2) Switch "ON" the breaker on the rear panel.
- 3) After the STP pump completes the self test and enters the levitation state or the error message "CAUTION: Bad EEPROM content" is displayed, set MANUAL/REMOTE changeover switch to the manual and press the "RESET" switch on the front panel for approx. 5 seconds. Tuning starts with "Tuning!" displayed on the LCD.

When the tunable error message such as "CAUTION: Bad EEPROM content" is displayed, it takes approx. 20 seconds until the display changes "Tuning".

- 4) Approx. one minute later the LCD displays "Tuning Complete", next it displays "Levitation". This completes the tuning. (When changing the MANUAL/REMOTE changeover switch, set to its setting before tuning.)



- ◇ **DO NOT turn off the primary power (DO NOT switch the breaker "OFF") during tuning. When doing so, perform tuning again. "CAUTION : PCB&Pump EEPROM Failure" may be displayed after powering ON again. When tuning is performed with this message, the setting is initialized. Reconfigure the setting if it has been changed by customer.**



- ◇ Tuning can be performed only while the STP pump is in the **LEVITATION** state (It cannot be performed while the STP pump is in the **ACCELERATION**, **NORMAL OPERATION**, or **BRAKE** state).
- ◇ When performing the tuning during remote operation, use the **"RESET"** switch on the front panel after switching the **"REMOTE"** switch to the manual. (The remote signal cannot be used for tuning.)
- ◇ Once tuning is completed, re-tuning is not required unless the configuration (the STP pump serial number, the STP control unit serial number, and the STP connection cable length) is changed.
- ◇ Although the STP pump sounds during tuning, this is not an indication of abnormality.

9.1.2 Each of data after tuning

The specific information and the user setting are recorded in the STP pump and STP control unit.

When tuning after changing the configuration (the STP pump serial number, the STP control unit serial number), the STP pump data overrides the STP control unit data except control unit serial No. and total hours of running (control unit).

Table 9.1 shows the data recorded in the STP control unit.

The user setting may be changed when replacing the STP pump. Confirm the setting after tuning, and reconfigure the setting when the user setting has changed.

Table 9.1 Data List

Data	Data priority	Reconfiguration
Pump serial No.	Pump	Unnecessary (specific information)
Control unit serial No.	Control unit	
Total hours of running (Pump)	Pump	
Total hours of running (Control unit)	Control unit	
Number of starts	Pump	
Error record	Pump	
Remote operation mode/Detailed	Pump	Necessary (user setting)
Rated speed	Pump	
Valid/invalid TMS function	Pump	
Valid/invalid of inhibit function	Pump	
Valid/invalid of Emergency vent.	Pump	

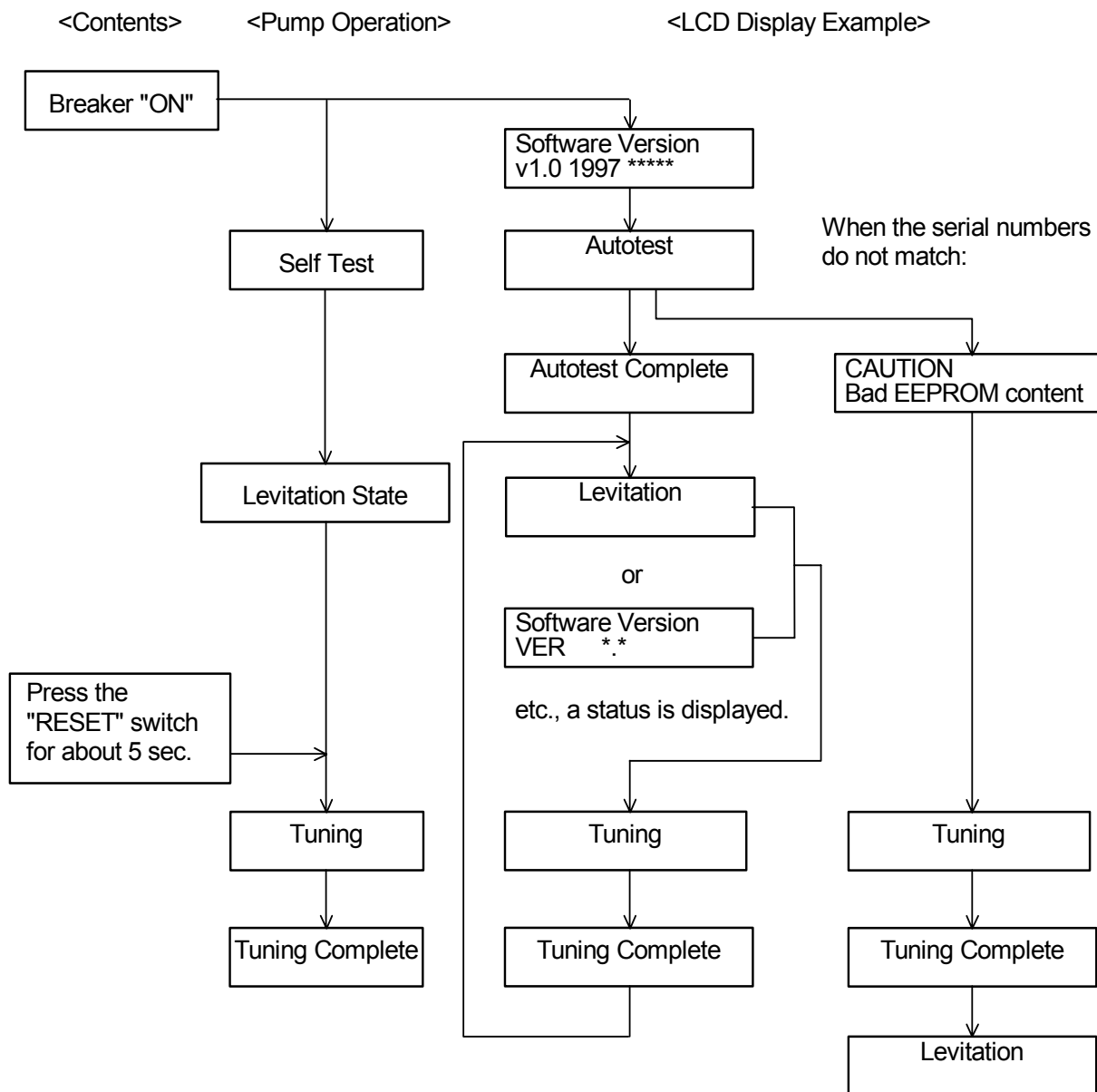

Operation

Figure 9.1 Tuning Procedures

9.2 Confirmation Mode

Confirmation Mode is used to check the status of the STP pump and STP control unit. The following items can be checked in Confirmation Mode:

- (1) Version information
- (2) Individual information (serial number, total hours of running, and number of starts)
- (3) Current settings (rated speed, TMS temperature setting, and actual pump temperature)
- (4) Current function settings (remote mode, TMS function, inhibit command, and emergency vent. valve)
- (5) Error record (lists up to 10 of the most recent errors)



- ◇ **The emergency vent. valve is not used with this series of STP pump.**

<Confirmation Method> (See Figure 9.2)

- 1) Press the "SELECT" switch to enter Confirmation Mode. The available menu groups (items (1) through (5) above) are displayed in order.
- 2) Press the "UP" switch to display the next item. Press the "DOWN" switch to display the previous item.
- 3) Press the "SELECT" switch to display the next menu group.
- 4) Press the "UP" and "DOWN" switch to confirm the status of the items of the currently selected menu group.
- 5) Press the "SELECT" switch to return to Operation Mode when viewing the Error Record. Or, if no switch is pressed for approx. 1 minute, the display will automatically revert to Operation Mode.

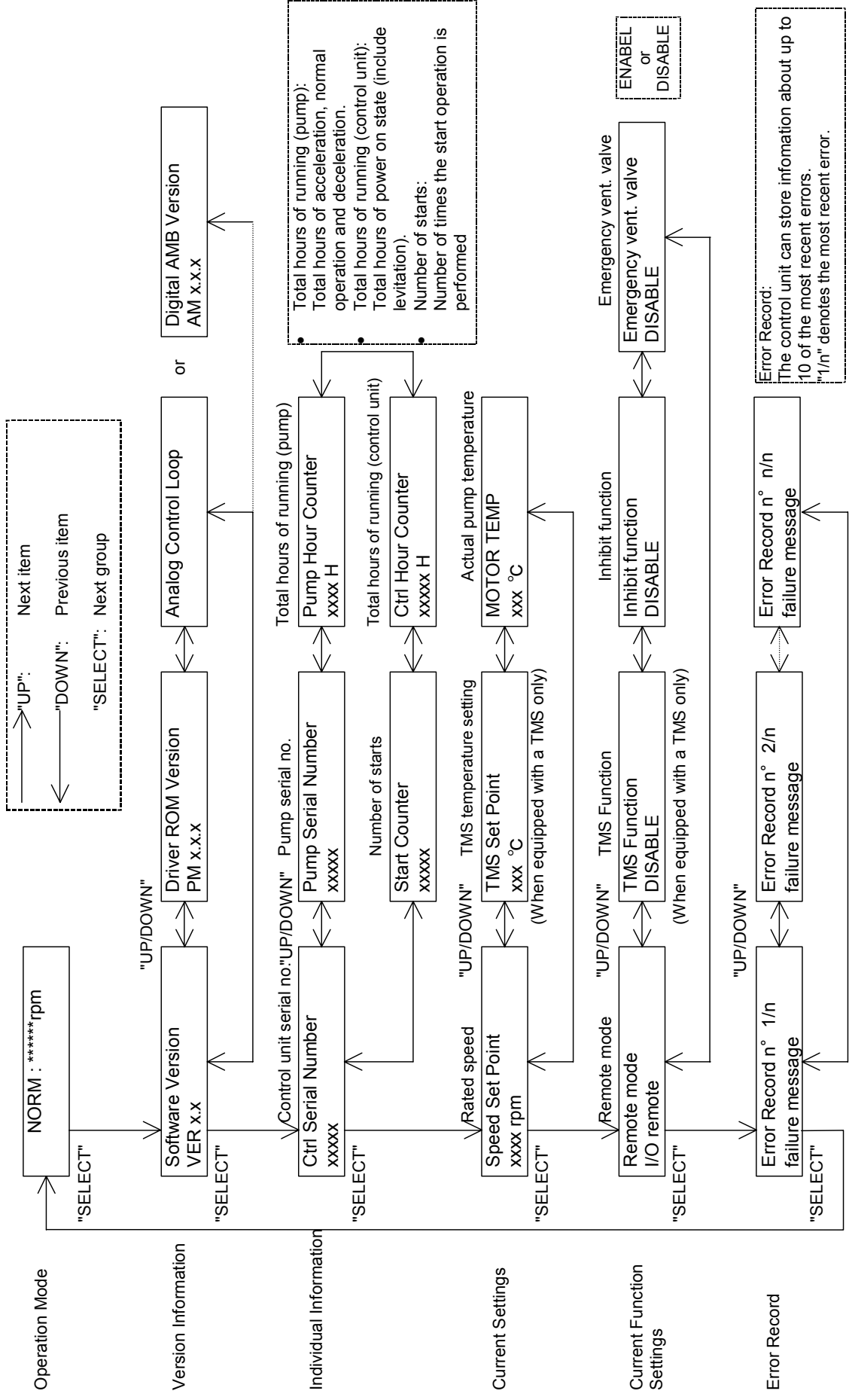

Figure9.2 Confirmation Mode Operation Method

9.3 Parameter Set Mode

Parameter Set Mode is used to set the different parameters of the STP pump and STP control unit. The following items can be set in Parameter Set Mode:

- (1) Remote mode
- (2) Rated speed
- (3) TMS function enable/disable
- (4) Inhibit function enable/disable
- (5) Emergency vent. valve function enable/disable
- (6) Remote mode configuration



- ◇ **The emergency vent. valve is not used with this series of STP pump.**

<Parameter Set Mode> (See Figure 9.3)

- 1) Push the "SELECT" and "UP" switches at the same time to enter Parameter Set Mode.
The available menu items (items (1) through (6) above) are displayed in order.
- 2) Press the "UP" switch to display the next parameter and the "DOWN" switch to display the previous one.
- 3) Press the "ENTER" switch to set the parameter to the new setting.
- 4) Press the "SELECT" switch to display the next item.
- 5) Change the parameter by pressing the "UP" and "DOWN" switches, then set it by pressing the "ENTER" switch.
- 6) When the save screen is displayed, select "YES" then press the "ENTER" switch to store the new parameters. "IN PROGRESS" is displayed on the LCD followed by "STORAGE OK", when the new parameters have been stored successfully, or "STORAGE NOT OK", when the new parameters have been stored unsuccessfully.
- 7) Press the "SELECT" switch to return to Operation Mode.
Or, do not press any switch for approx. 1 minute and the display will automatically revert to Operation Mode.
- 8) Select "NO" and press the "SELECT" switch to return to Operation Mode without saving the new parameters.

NOTICE

- ◇ Do not set the "RS232/485 Com", "RS232/485 Modbus", and "LONWORKS" settings of Remote Mode because they cannot be set in the current configuration.

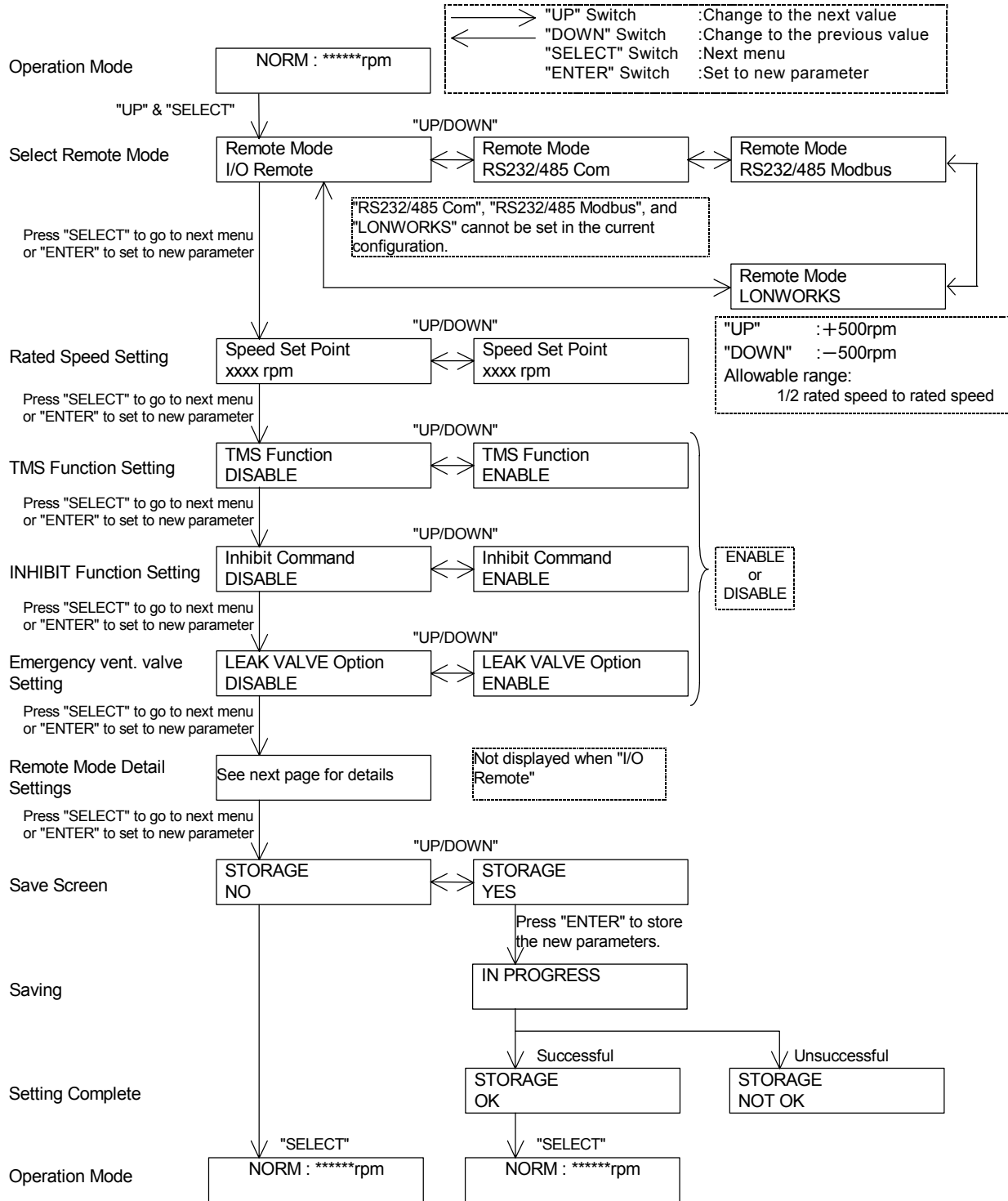

Operation

Figure 9.3 Parameter Setting Method

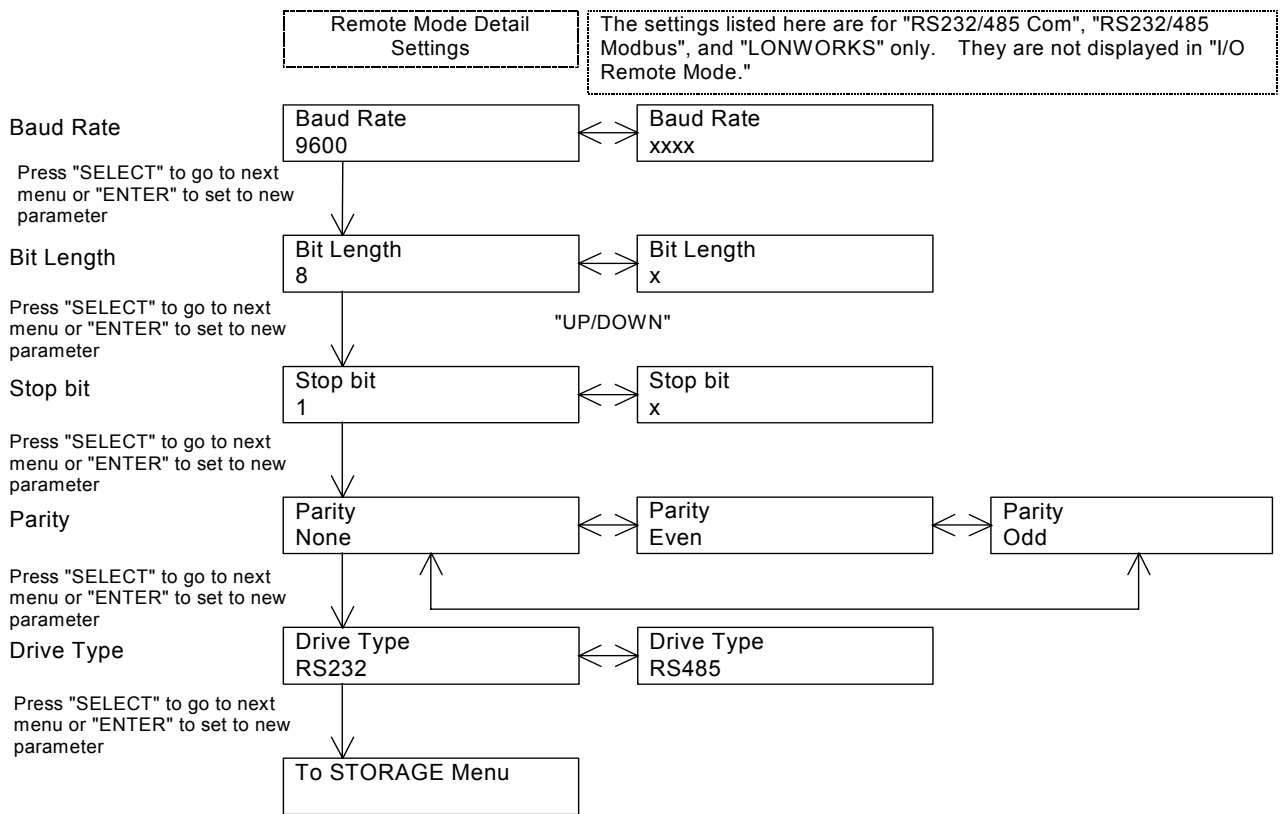

Operation

Figure 9.4 Remote Mode Setting Method

10 Safety Functions

10.1 Power Failure

< I . Operation at a Power Failure >

When the power voltage drops below 80 V due to a power failure or other, the normal operation of the magnetic bearing is maintained using the regenerative energy of the rotating rotor (backup operation during a power failure).

- 1) When the rotational speed is 8,000 rpm or more at a power failure:
 - i. The STP control unit detects any power failure of 2 seconds or more and the STP pump decelerates.
 At this time, the "POWER" lamp goes out and the "FAILURE" lamp lights. The LCD displays "Mains Failure." Also, an alarm signal is output from REMOTE X7 pins (14)-(33) and (15)-(33).
 When the rotational speed goes down to approx. 8,000 rpm, the rotor lands on the touch down bearing and stops. The "FAILURE" lamp goes out and the LCD is turned off. Also, the alarm signal output is reset.
 - ii. The STP control unit does not detect a power failure of less than approx. 2 seconds, continuing rotating the STP pump.
- 2) When the rotational speed is less than approx. 8,000 rpm at a power failure:
 The STP control unit does not detect the power failure. The rotor lands on the touch down bearing and stops.

< II . Operation after a Power Recovery >

1) MANUAL operation

The magnetic bearing operation and LED lamp and LCD messages are recovered after a power recovery. The "FAILURE" lamp goes out.

- The STP pump continues decelerating even after a power recovery. Press the "START" switch to reaccelerate the STP pump.

2) REMOTE operation

The magnetic bearing operation and LED lamp and LCD messages are recovered after a power recovery. The "FAILURE" lamp goes out.

- When the START signal is input to the REMOTE input pin after a power recovery, the STP pump reaccelerates.
- When the START signal is not input to the REMOTE input pin after the power recovery, the STP pump continues the BRAKE operation.



- ◇ **Establish a sequence so that the power can be supplied to the STP control unit immediately after a power recovery.**

Table 10.1 shows the states of LCD, LED lamps, and REMOTE output signals at a power failure.

Also, Table 10.2 shows the operations of the STP pump after a power recovery.

Table 10.1 States of Lamps and REMOTE Output Signals at a Power Failure

Rotational speed (rpm)	LCD Message	LED lamps		REMOTE output signals (REMOTE X7)	
		POWER lamp	FAILURE lamp	Power ON signal	ALARM signal
8,000 or more	Mains Failure	OFF	ON	OFF	ON
Less than 8,000	OFF	OFF	OFF	OFF	OFF

Table 10.2 Operations of the STP Pump after a Power Recovery

Rotational speed (rpm)	Duration of power failure	MANUAL operation	REMOTE operation	
		STP pump operation after a power recovery	"START" REMOTE signal input after a power recovery	STP pump operation after a power recovery
8,000 or more	Approx. 2 sec. or more	Deceleration/Stop	Yes	Reacceleration
	Less than approx. 2 sec.		No	Deceleration/Stop
Less than 8,000	X	Deceleration/Stop	Yes	Reacceleration
			No	Deceleration/Stop

10.2 Abnormal State of Magnetic Bearing

When the magnetic bearing does not function normally due to a breakage of the STP connection cable, disconnection of connectors or any abnormality/error of the STP control circuit, the rotor falls on the touch down bearing and stops.

The "FAILURE" lamp lights and the LCD displays error message "Disturbance*_*."



- ◇ **When an abnormality/error occurs in the magnetic bearing, check the STP pump as well as the STP control unit. If "FAILURE" cannot be released after reset operation, contact Service office.**

10.3 Excessive Vibration

When serious vibration or mechanical shock causes the rotor to touch the touch down bearing (due to external vibration/impact, intrusion of atmosphere or foreign materials into the STP pump or rotor imbalance), the STP pump decelerates and stops.

The "FAILURE" lamp lights and the LCD displays error message "Disturbance*_*."

10.4 Motor Driver Overload

When the STP pump does not attain the rated speed within approx. 30 minutes after starting or when the ACCELERATION state remains unchanged during operation for approx. 30 minutes, the STP pump decelerates and stops.

The "FAILURE" lamp lights and the LCD displays error message "DRIVER Overload".

10.5 Overheating Inside the STP Pump

When the temperature of the motor inside the STP pump overheats due to an abnormal baking temperature or overload operation, the STP pump decelerates and stops.

The "FAILURE" lamp lights and the LCD displays error message "MOTOR Overheat".

10.6 Overheating Inside the STP Control Unit

When the temperature inside the STP control unit overheats due to a failure in the air cooling fan, external heat source, and other, the WARNING message "CAUTION: CNT heat*" is displayed. In this case, the STP pump does not stop. If the STP control unit overheats further, the STP pump decelerates and stops. The "FAILURE" lamp lights and the LCD displays error message "CNT Overheat".

10.7 Overspeed

When the rotational speed of the STP pump exceeds the specified rotational value due to a failure in the motor driver, the breaker in the STP control unit switches "OFF." The STP pump has no power supplied and stops. The "FAILURE" lamp lights and the LCD displays error message "OVERSPEED*".

10.8 Abnormality/Error in the TMS Unit (for Use with the TMS Unit)

1) Abnormality/Error in the TMS Unit

- i If the temperature of the STP pump base unit is +10°C higher or -10°C lower than the setting value due to the occurrence of an abnormality/error in the TMS heater or other causes, the STP pump decelerates and stops.
Output of the heater and the cooling water unit is OFF.
The "FAILURE" lamp lights and the LCD displays error message "TMS Higher Temp." (over +10°C) or "TMS Lower Temp. " (below -10°C).



- ◇ **An abnormality/error is not detected even at -10°C or less lower than the setting value within approx. one hour after the STP pump starts.**
- ii If an abnormality/error shown in "i" above is not detected and the TMS heater overheats, the STP pump decelerates and stops.
Output of the heater and the cooling water unit is OFF.
The "FAILURE" lamp lights and the LCD displays error message "TMS Overheat".

2) Disconnecting of the TMS Connection Cable and Connectors

When an abnormality/error occurs in the TMS connection cable, the STP pump decelerates and stops.

Output of the heater and the cooling water unit is OFF.

The "FAILURE" lamp lights and the LCD displays error message "T.Cable Disconnect".

Table 10.3 Safety Functions (1/2)

Abnormality /Error	Operation state of safety functions	Lamp indication	LCD	REMOTE output signal	State of the STP pump	Probable causes of an abnormality/error	Reset by RESET switch
Power failure	Power failure time: 2 seconds or more	"FAILURE" lights. "POWER" goes out.	"Main Failure"	"ALARM" "POWER ON" output cut-off	The magnetic bearing continues to operate using regenerative energy. The STP pump decelerates and stops. The rotor lands on the touch down bearing.	Power failure. Power cable breakage. Power cable disconnection.	Impossible
Abnormal magnetic bearing	Rotor descends onto the touch down bearing.	"FAILURE"	"Disturbance * _"	"ALARM"	The STP pump stops.	STP connection cable breakage. STP connection cable disconnection. Abnormal control circuit.	Possible
Excessive vibration	Rotor vibrates excessively to come into contact with the touch down bearing.	"FAILURE"	"Disturbance * _"	"ALARM"	The STP pump decelerates and stops.	External vibration and impact. Intrusion of atmospheric air. Intrusion of foreign materials.	Possible
Overload of motor driver	The STP pump does not attain the rated speed 30 minutes or more after it starts.	"FAILURE"	"DRIVER Overload"	"ALARM"	The STP pump decelerates and stops.	Leakage from the vacuum equipment or piping. Insufficient pressure at inlet and outlet port sides. Failure of starting of the backing pump.	Possible

Table 10.3 Safety Functions (2/2)

Abnormality /Error	Operation state of safety functions	Lamp indication	LCD	REMOTE output signal	State of the STP pump	Probable causes of an abnormality/error	Reset by RESET switch
Overheating inside the STP pump	Temperature of the STP pump motor rises.	"FAILURE"	"MOTOR Overheat"	"ALARM"	The STP pump decelerates and stops.	Abnormal baking temperature. Insufficient cooling. Leakage of vacuum equipment or piping. Continuous repetition of startup/stop. Extraordinarily-high temperature.	Possible
Overheating inside the STP control unit	Temperature inside the STP control unit rises.	"FAILURE"	"CAUTION: CNT heat*"	"ALARM"	The STP pump does not stop.	Failure in the cooling fan. Shielding of cooling air inlet and ventilation port. Extraordinarily-high temperature.	Possible
			"CNT Overheat*"	"ALARM"	The STP pump decelerates and stops.		
Overspeed	Rotational speed of the STP pump over the specified speed.	"FAILURE"	"OVERSPEED*"	"ALARM"	Breaker OFF. Power failure state is entered and the STP pump stops.	Failure in the motor driver.	Impossible

Table 10.4 Safety Functions (When the TMS Unit is Used)

Abnormality /Error	Operation state of safety functions	Lamp indication	LCD	REMOTE output signal	State of the STP pump	Probable causes of an abnormality/error	Reset by RESET switch
Failure of TMS unit	Abnormal temperature	"FAILURE"	"TMS Higher Temp."	"ALARM"	The STP pump decelerates and stops. Output of heater and cooling water valve is OFF.	Abnormal cooling water. Heater disconnect.	Possible
	Setting temperature +10°C or more -10°C or less		or "TMS Lower Temp."				
Failure of TMS connection cable	TMS heater overheats	"FAILURE"	"TMS Overheat"	"ALARM"	The STP pump decelerates and stops. Output of heater and cooling water valve is OFF.	Error/abnormality detection above does not function.	Impossible
	TMS connection cable or its connector is disconnected.	"FAILURE"	"T.Cable Disconnect"	"ALARM"	The STP pump decelerates and stops. Output of heater and cooling water valve is OFF.	TMS connection cable breakage. TMS connection cable disconnection.	Impossible

11 Troubleshooting, Maintenance, and Inspection

The STP pump is provided with safety functions for various abnormality/errors.

When an abnormality/errors occurs in the pump or control unit, the safety function operates with the "FAILURE" lamp lit, and an alarm signal is output from the remote output pins. An error message showing the number of the error in the form "Error n° **/**" and the contents of the error are displayed alternately on the lower line of the LCD.

If an abnormality/error is found when using the STP pump, check it and take measures in accordance with the following procedures.

If you cannot trace it or if the STP pump does not function normally after the troubleshooting, fill in the necessary information in the "Malfunction information" and fax it to Service office.

11.1 Troubleshooting Immediately after an Abnormality/Error Occurs

11.1.1 Troubleshooting Power Failure

Establish a sequence so that the power can be supplied to the STP control unit immediately after a power recovery.

11.1.2 Troubleshooting Other Abnormality/Error

Refer to Section 7.4.6 and 7.5.5, "Starting the STP Pump after a Safety Function Operates."

- i. After confirming the "BRAKE" lamp goes out and the STP pump stops, remove the probable cause of the abnormality.
When the LCD displays an error message, take the necessary action according to Section 11.2, "When Error Message is Displayed on LCD."
- ii. Perform the RESET operation according to turn off the "FAILURE" lamp.
- iii. Perform the START operation. Check if the STP pump operates correctly.



- ◇ **When disconnecting cables from the STP pump and/or the STP control unit to perform troubleshooting and take the necessary action, confirm that the STP pump stops, turn OFF the primary power (Switch the breaker "OFF"), then disconnect the cables.**
- ◇ **If the RESET operation does not turn off the "FAILURE" lamp, confirm that the STP pump stops, turn OFF the primary power (Switch the breaker "OFF"), then turn ON the primary power again (Switch the breaker "ON").**

11.2 When Error Message is Displayed on LCD

11.2.1 Error Messages

When error is detected, "Error n° **/**" and the error message are displayed on the lower line of the LCD alternately. The first number of "**/**" is the order of detected errors that have occurred. Thus, a "1/3" would denote the fastest error of 3 errors. Press the "UP" or "DOWN" switch to scroll display the contents of the next or previous error message. (The "UP" or "DOWN" switch can also be input in Remote Mode.)

Example)

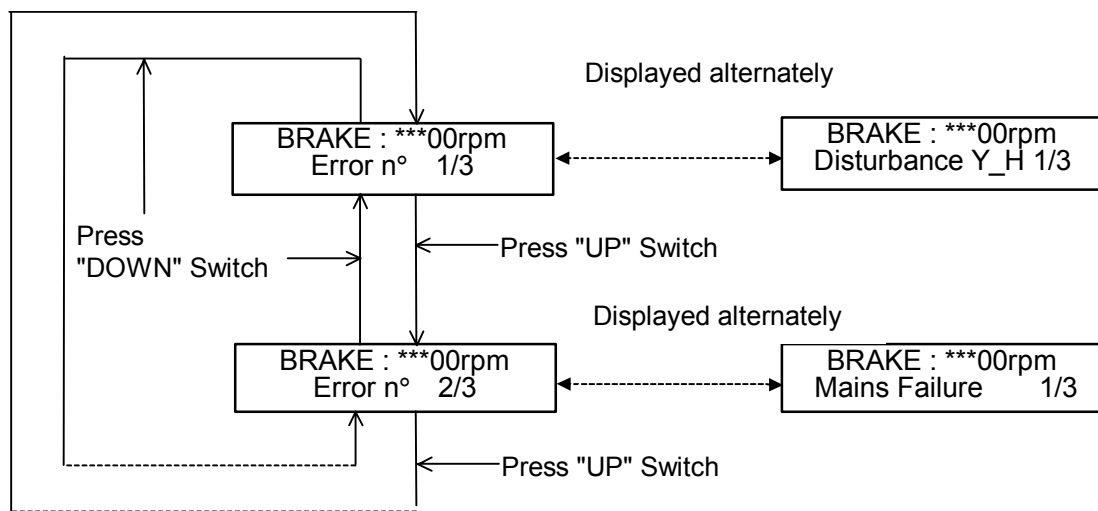

NOTICE

- ◇ The upper message on the LCD shows the current STP pump operation state.
- ◇ When the message on the LCD is in Confirmation mode or Parameter Set mode, press the "SELECT" switch several times to change it to the status display mode.

Table 11.1 Error Messages

LCD Messages	Probable Causes	Countermeasures	Referred Section
CAUTION Bad PCB EEPROM	<ol style="list-style-type: none"> 1) Turning on the power after "Tuning Error" is detected. 2) Abnormal data in STP control unit. 3) Failure of the STP control unit. 	<ol style="list-style-type: none"> 1) Perform tuning. 2) Perform tuning. 3) Contact Service office. 	<p>9.1</p> <p>9.1</p> <p>Malfunction information</p>
CAUTION Bad Pump Identifier	Use of different series of the STP pump and the STP control unit.	Use the same series of the STP pump and the STP control unit.	—
CAUTION Bad EEPROM content	Use of different serial No. of the STP pump and the STP control unit.	Perform tuning.	9.1
CAUTION Bad Pump EEPROM	<ol style="list-style-type: none"> 1) Abnormal data in STP pump unit. 2) Failure of the STP pump. 	<ol style="list-style-type: none"> 1) Perform tuning. 2) Contact Service office. 	<p>9.1</p> <p>Malfunction information</p>
CAUTION Different Pump_ID	Failure of the STP pump.	Contact Service office.	Malfunction information
CAUTION :PCB& Pump EEPROM Failure	<ol style="list-style-type: none"> 1) Power is turned off during turning 2) Use of different version of the software. 3) Failure of the STP pump or the STP control unit. 	<ol style="list-style-type: none"> 1) Perform turning again. Reconfigure the initialized settings. 2) Perform tuning. 3) Contact Service office. 	<p>9.1</p> <p>9.3</p> <p>9.1</p> <p>Malfunction information</p>
CAUTION : CNT heat 1 CAUTION : CNT heat 2	<p>Overheat inside the STP control unit (the STP pump does not stop):</p> <ol style="list-style-type: none"> 1) High ambient temperatures 2) Insufficient cooling of the STP control unit. 3) Failure of the air cooling fan in the control unit 	<ol style="list-style-type: none"> 1) Set the ambient temperature to 40°C or less. 2) Remove obstacle from the ventilation port. 3) Repair is needed. Contact Service office. 	<p>6.2.1</p> <p>6.2.2</p> <p>Malfunction information</p>
CAUTION PCB & Pump Failure	Failures of the STP pump and the STP control unit.	Contact Service office.	Malfunction information
CNT Overheat 1 CNT Overheat 2	<p>Overheat inside the STP control unit:</p> <ol style="list-style-type: none"> 1) High ambient temperature 2) Insufficient cooling of the STP control unit 3) Failure of the air cooling fan in the control unit 	<ol style="list-style-type: none"> 1) Set the ambient temperature to 40°C or less. 2) Remove obstacle from the ventilation port. 3) Repair is needed. Contact Service office. 	<p>6.2.1</p> <p>6.2.1</p> <p>Malfunction information</p>

Troubleshooting

LCD Messages	Probable Causes	Countermeasures	Referred Section
DRIVER Overload	The motor driver overload. (when the rated operation does not start approx. 30 min. after start operation is executed: ACCELERATION state continues for approx. 30 minutes: 1) High pressure at the inlet port 2) High pressure at the outlet port 3) Leakage of the piping system 4) Failure of the backing pump	1) Use the maximum working pressure or less. 2) Use the allowable backing pressure or less. 3) Check the vacuum piping system for leakage. 4) Check the backing pump for its capacity and START state (use a pump with the recommended capacity or more)	4.3.4 13.1 4.3.4 13.1 4.3.4 13.1 4.3.4 13.1
DRIVER Overvoltage	Failure of the STP control unit.	Contact Service office.	Malfunction information
DRIVER Sensor Lost	Failure of the STP control unit.	Contact Service office.	Malfunction information
DRIVER com. Failure	Failure of the STP control unit.	Contact Service office.	Malfunction information
DSP->PCB com fail	Failure of the STP control unit.	Contact Service office.	Malfunction information
Disturbance X_B Disturbance X_H Disturbance Y_B Disturbance Y_H Disturbance Z	Abnormal magnetic bearing: 1) Change of the cable length 2) Disconnection of the STP connection cable or control circuit error	1) When changing the cable length, perform tuning. 2) Contact Service office.	9.1 Malfunction information
	Excessive vibration applied externally to the STP pump: 1) External vibration/impact. 2) Atmospheric air flows the STP pump 3) Foreign materials fall into the STP pump	1) Remove external vibration so as not to transmit it to the STP pump. 2) Check the vacuum piping. 3) Install the STP pump in a way that no foreign materials fall into the STP pump.	4.3.4 4.3.4 4.2.1
EPROM Error	Failure of the STP control unit.	Contact Service office.	Malfunction information

Troubleshooting

LCD Messages	Probable Causes	Countermeasures	Referred Section
Error Message n° **/**	If an error occurs (**/** shows the number of errors occurred) .	Refer to the respective error message.	11.2
First Damage Limit	First damage phenomenon appeared on the touch down bearing (the STP pump does not stop).	Overhaul is needed. Contact Service office.	Malfunction information
E.Valve Disconnect	Disconnection of the emergency vent valve cable (not used in this specification model).	Connect the cable correctly. If the cable connector is not locked, lock it securely.	X
	Failure of the emergency vent valve cable (not used in this specification model).	Contact Service office.	
	Incorrect setting of the emergency vent valve (not used in this specification model).	When the emergency vent valve function is set to "ENABLE," set it to "DISABLE".	9.3
MOTOR Overheat	Overheating inside the STP pump:		
	1) Overheating during baking	1) Set the temperature of the baking heater to 120°C or less.	5.3
	2) Insufficient cooling	2) At the time of baking or gas pumping, always cool the STP pump.	5.2
	3) Leakage of the vacuum piping system	3) Check the piping system for leakage.	4.3.4
4) Repetitious start/stop operations	4) Repetitious start/stop operations may cause the STP pump to overheat.	7.3	
M_TEMP SENSOR LOST	Failure of the STP pump.	Contact Service office.	Malfunction information
Mains Failure	Insufficient power supply:		
	1) Power failure	1) Check whether or not a power failure has occurred.	10.1
	2) Incorrect connection of the power cable.	2) Connect the power cable correctly.	6.4.2
	3) Failure of the power cable	3) Replace the power cable.	Malfunction information
4) Failure of the power voltage	4) Set the voltage to the rated voltage ± 10%.	6.4.2 13.2	
No Levitation	The rotor does not levitate.	Refer to the respective error message.	11.2
OVERSPEED 1 OVERSPEED 2 OVERSPEED 3	Overspeed of the STP pump.	Contact Service office.	Malfunction information

LCD Messages	Probable Causes	Countermeasures	Referred Section
P.Cable Disconnected	Incorrect connection of the STP connection cable.	Connect the cable correctly. If the cable connector is not locked, lock it securely.	6.4.2
	Failure of the STP connection cable.	Contact Service office.	Malfunction information
PCB->DSP com fail	Failure of the STP control unit.	Contact Service office.	Malfunction information
Power Supply Failure	Failure of the STP control unit.	Contact Service office.	Malfunction information
RAM Error	Failure of the STP control unit.	Contact Service office.	Malfunction information
START NOT ALLOWED	When the extent of the damage on the touch down bearing exceeds the second damage limit and the start is not allowed.	Overhaul is needed. Contact Service office.	Malfunction information
Second Damage Limit	When the extent of the damage on the touch down bearing exceeds the second damage limit and the start is not allowed.	Overhaul is needed. Contact Service office.	Malfunction information
Speed Pulse Lost	Failure of the STP pump.	Contact Service office.	Malfunction information
	Failure of the STP control unit.	Contact Service office.	Malfunction information
T.Cable Disconnect	Disconnection of the TMS connection cable.	Connect the cable correctly. If the cable is not locked, lock it securely.	6.4.2
	Failure of the TMS connection cable.	Contact Service office.	Malfunction information
	Disconnection of the TMS sensor.	Contact Service office.	Malfunction information
	Incorrect setting of the TMS function.	When the TMS function is in no use, set the TMS function to "DISABLE".	9.3
TMS Breaker Trip	The TMS unit earth leakage breaker (optional) is "OFF" 1) Incorrect setting of the TMS unit earth leakage breaker. 2) Failure of the TMS heater or the valve	1) Always remain the TMS unit earth leakage breaker "ON." 2) Contact Service office.	Instruction Manual of TMS Unit Problem Check Sheet

Troubleshooting

LCD Messages	Probable Causes	Countermeasures	Referred Section
TMS Higher Temp.	TMS temperature control error (when the TMS unit detection temperature becomes +10°C or more): 1) Insufficient cooling of the TMS unit 2) Failure of the TMS unit	1) Connect the cooling water electromagnetic valve correctly. Check the amount and the temperature of cooling water. 2) Contact Service office.	Instruction Manual of TMS Unit Malfunction information
TMS Lower Temp.	TMS temperature control error (when the detection temperature of the TMS unit becomes -10°C or less: such error cannot be detected within 1 hour after startup): 1) Failure of the TMS heater 2) Failure of the TMS unit	1) Contact Service office. 2) Contact Service office.	Malfunction information Malfunction information
TMS overheat	Overheat of the TMS heater: 1) Failure of the TMS heater 2) Failure of the TMS unit	1) Contact Service office. 2) Contact Service office.	Malfunction information Malfunction information
Tuning Error 1 Tuning Error 2 Tuning Error 3 Tuning Error 4 Tuning Error 5	Tuning errors	"No LEVITATION" is displayed. Perform tuning again after turning on the power.	9.1
w (appears on the upper right LCD display)	When any warning message appears on the LCD display.	Refer to the respective warning message.	11.4

11.3 Other Abnormalities

11.3.1 Abnormalities When Powering ON

(When the "FAILURE" lamp lights and the LCD displays an error message, see Section 11.2, "When Error Message is Displayed on LCD.")

Table 11.2 Troubleshooting after Powering ON

No.	Symptom	Probable cause	Countermeasures	Referred Section
1	The "POWER" lamp does not light when powering ON.	Incorrect connection of power cable	Connect the power cable correctly.	6.4.2
		Abnormal power voltage	Set the voltage to rated voltage $\pm 10\%$.	6.4.2 13.2
		Power failure	Check whether or not a power failure has occurred.	10.1

11.3.2 Abnormalities When Performing the STP Pump Start Operation

(When the "FAILURE" lamp lights and the LCD displays an error message, see Section 11.2, "When Error Message is Displayed on LCD.")

Table 11.3 Troubleshooting When Performing the STP Pump Start Operation

No.	Symptom	Probable cause	Countermeasures	Referred Section
1	The "ACCEL." lamp does not light.	The "MANUAL/REMOTE" changeover switch is not at the correct position.	Slide the "MANUAL/REMOTE" changeover switch to the correct position.	6.1.1 7.5 7.6
		ROTATION INHIBIT signal input pins (REMOTE X7 (1)-(5)) are opened.	When not using this function, short the circuits between (1)-(5), or set "Inhibit Command" to "DISABLE." If these pins are opened, the STP pump will not rotate after performing start operation.	8.1 9.3

11.3.3 Other Abnormalities

(When the "FAILURE" lamp lights and the LCD displays an error message, see Section 11.2, "When Error Message is Displayed on LCD.")

Table 11.4 Troubleshooting While the STP Pump Is Rotating

No.	Symptom	Probable causes	Countermeasures	Referred Section
1	Insufficient ultimate pressure	Failure of the backing pump	Check the capacity and starting state (use a backing pump having more capacity than we specified).	4.3.4 13.1
		Leakage of the piping system	Check the piping system for leakage.	4.3.4
		Residual molecules	If the main composition is H ₂ or H ₂ O, perform baking; if it is other gases, clean the inside of the vacuum equipment (If gases remain inside the STP pump, contact Service office when it is needed to be cleaned).	5.3 11.8.3
2	The STP pump stops.	ROTATION INHIBIT signal input pins (REMOTE X7 (1)-(5)) are opened.	When not using this function, short the circuit between (1)-(5), or set "Inhibit Command" to "DISABLE". If these pins are opened, the STP pump will not rotate after performing start operation.	8.1 9.3
3	The TMS unit does not function	Incorrect settings of TMS function	When using the TMS unit, set "TMS Function" to "ENABLE".	9.3
4	ROTATION INHIBIT signal does not function correctly.	Incorrect settings of Inhibit function	When using the ROTATION INHIBIT signal, set "Inhibit Command" to "ENABLE".	9.3
5	The E. V. valve does not function (The E.V. valve is not used with this series of the STP pump).	Incorrect settings of the E. V. valve function	When using the E. V. valve, set "emergency vent. Valve function" to "ENABLE".	X

11.4 "WARNING" Message Display Function

The STP control unit is provided with a "WARNING" message to display when an overhaul is needed following a self test.

When a "w" appears in the upper left hand corner of the LCD, press and hold the "ENTER" switch to display the warning message. The warning message indicates that an overhaul is necessary. Please contact Service office for an overhaul. (The "ENTER" switch can also be used in Remote Mode.)

Example:

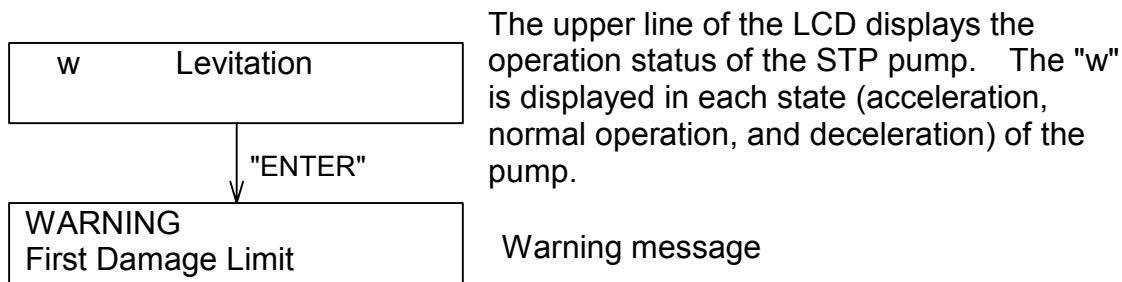

- ◇ The "WARNING" message cannot be reset by the "RESET" switch. Service office is in charge of resetting the "WARNING" message.
- ◇ The STP pump can operate even when the "WARNING" message is displayed. It is recommended to have the STP pump overhauled as soon as possible.
- ◇ The STP pump can operate even when the "WARNING" message is displayed except when "Second Damage Limit" is displayed. Overhaul the STP pump when "Warning" message is displayed.

11.4.1 First Damage Limit

The touch down bearing inside the STP pump will be worn out caused by impact or air in rush from outside. Also, touch down at the power failure causes wear. The STP control unit adds the damage point at each "Disturbance" and "Mains Failure" error. "First Damage Limit" is displayed when the accumulation point attains the prime setting value. "First Damage Limit" cannot be reset. It is recommended to have the STP pump overhauled as soon as possible.

11.4.2 Second Damage Limit

"Second Damage Limit" is displayed when continuing to operate the STP pump after "First Damage Limit" is displayed, and the accumulation of the damage point attains the second setting value by generating second "Disturbance" or "Mains Failure". Overhaul the STP pump because the STP pump cannot perform the rotational operation when "Second Damage Limit" is displayed.

11.5 "ERROR RECORD" Message Display Function

The STP control unit can display the contents of up to the last 10 errors on the LCD.

To view the error record, push the "SELECT" switch follow the instructions for entering Confirmation Mode in Section 9. The error number of up to the last 10 errors is displayed on the upper line of the LCD in the form "Error Record n^o */*", and the contents of the error is displayed on the lower line.

The first number of "**/**" shows the number of the error (the most recent error is number 1) and the second number shows the number of errors that have occurred up to 10. Thus, a "1/3" would denote the most recent error of 3 errors. Press the "UP" or "DOWN" switch to scroll display the contents of the next or previous error in the error record. (The "UP" and "DOWN" switch can also be input in Remote Mode. See Section 9.3 for a more detailed explanation of Confirmation Mode.

11.6 Maintenance and Inspection



- ◇ When performing maintenance and inspections of the STP pump, exhaust gases inside the STP pump thoroughly. Residual gases may cause an accident when removing the STP pump. Confirm the characteristics of gas to be used, referring to the Material Safety Data Sheet (MSDS) you obtain from the gas supplier. Wear personal protective equipment if necessary.



- ◇ Stop the STP pump, and turn OFF the primary power (Switch the breaker "OFF"), before performing maintenance and inspections of the STP pump and STP control unit. Failure to do so may result in the inadvertent rotation of the STP pump, which may result in an accident.
- ◇ Do not touch any place other those specified when performing maintenance or inspecting the pump and NEVER open any panel because it could cause shock, malfunction, or short circuit.
- ◇ Power OFF the baking heater and other peripheral equipment before performing maintenance and inspections.
- ◇ The wipes used for clean and decontamination might become hazardous waste depending upon the solvent (alcohol). Dispose of the contaminated wipes appropriately according to the regulations of each national and/or local government.

11.6.1 Cleaning and Decontamination

The method of cleaning and decontamination of the STP pump and STP control unit is shown below.

Table 11.5 Cleaning and Decontamination

Area		Cleaning and Decontamination
STP Pump	Exterior	Wipe with proper solvent (such as alcohol). Clean off with a pure gas when dust has accumulated in the connector. When the label of the STP pump has been damaged, contact Service office.
	Interior	The decontamination (overhaul) in the STP pump is executed in Service office. When overhaul is needed, contact Service office.
STP Control unit	Exterior	Wipe with proper solvent (such as alcohol). When dust has accumulated in the ventilation port, wipe off or vacuum it with the cleaner. In this case, dust must not enter in the STP control unit. Clean off with a pure gas when dust has accumulated in the connector. When the label of the STP control unit has been damaged, contact Service office.
	Interior	The cleaning (overhaul) in the STP control unit is executed in Service office. When overhaul is needed, contact Service office.

11.6.2 Inspecting the Deposit

Leaving the STP pump without removing the deposit may cause the STP pump to be corroded beyond repair.

Deposit may have accumulated inside the STP pump depending upon the type of the vacuum equipment installed in the STP pump. An increase in the amount of deposit may lead to a malfunction of the STP pump.

Therefore, perform regular maintenance (once every three to six months as a target).

Inspect the inside of the outlet port flange for adhesion of deposit while watching the outlet port flange. If deposit has accumulated to some extent, an overhaul (cleaning) is required. Contact Service office.

Note that the costs of troubleshooting problems resulting from deposit will be at your own charge even during the warranty period.

If a problem resulting from deposit occurs inside the STP pump, hermetically seal inlet port, outlet port, purge port, and leak port flanges, and immediately return them to Service office.

For the transport method, see Section 11.6.4, "Transport for Repair or Overhaul."



- ◇ **Contact with atmospheric air may cause a reaction of the deposit. DO NOT open the STP pump to atmospheric air as much as possible.**
- ◇ **BOC Edwards supplies you the Temperature Management System (TMS) unit to keep the temperature high inside the STP pump and prevent the accumulation of deposit. For details, contact BOC Edwards.**

11.6.3 Overhaul

The recommended maintenance intervals for different process applications are tabulated below:

	Process	Period	Remarks
Etching ^{*1}	Metal Etch	1 year	Ensure that TMS (Temperature Management System) is fitted and operational to prevent accumulation of by-product deposition in the pump.
	Other Etch Processes	2 years	
	It is recommended to change the pump rotor after 5 years due to accumulated wear of the protective plating material		
	Other semiconductor process	2 years	Processes resulting in accumulation of deposits in the pump will require more frequent service.
	Clean applications (Only vacuum pumping)	5 years	
	Other use	(2 years)	Dependent on application, contact BOC Edwards.



- ◇ **The touch down bearing inside the STP pump will be worn out after a number of full speed touchdowns. When the STP control unit displays "w," it is essential to have the touch down bearings replaced.**

The costs of replacing parts that need to be replaced because of deterioration or abrasion will be at your own charge.

When overhaul of the STP pump or the STP control unit is needed, contact Service office.

^{*1} "Etching" includes semiconductor etching and LCD etching.

11.6.4 Transporting for Repair or Overhaul



- ◇ When returning the STP pump which has used any kind of gases to Service office, fill the type of gas and handling precautions in the "Malfunction Information " and fax it to Service office. Confirm the characteristics of gas to be used, referring to the Material Safety Data Sheet (MSDS) you obtain from the gas supplier.
- ◇ Follow the instruction of "Return Procedure" to prevent an accident during the transportation, repair or overhaul.



- ◇ When returning the STP pump to Service office, be sure to pack it well to prevent external damage. If "Return Procedure" has not been satisfied, BOC Edwards will not be responsible for any troubles.

i) Always contact Service office before returning the STP pump for repairs, overhaul, or other purposes. To avoid any accident by gases or corrosion inside the STP pump, particularly when corrosive, reactive or flammable gases have been used, ii) Vacuum and hermetically seal the STP pump before transport. iii) Specify the type of gases used and handling precautions in the "Malfunction Information" and return the STP pump to Service office.

When returning the STP pump to Service office, be sure to pack it well to prevent external damage. Use similar or superior packaging material as originally supplied.

"Return Procedure" and the "Malfunction Information" are in the end of the Instruction Manual. When additional sheet is needed, contact Service office.



- ◇ The costs of cleaning and overhaul of the STP pump will be at your own charge.
- ◇ When returning the STP pump to Service office, fill in the necessary items in the "Malfunction Information" and fax it to Service office.

12 Storage and Disposal

12.1 Storage of the STP Pump

When the STP pump is left unused over a long period (more than a few months), follow the precautions below:

- 1) Close the inlet port of the STP pump and vacuum it using a backing pump.
- 2) Introduce dry N₂ gas or dry air from the outlet port or the purge port.
- 3) Close the outlet port and purge port.
- 4) If the STP pump is water cooled, introduce compressed air from one side of the cooling water port so that no water remains in the STP pump.
- 5) Store the STP pump in a vertical position.
- 6) DO NOT store the STP pump in the following places:
 - Place of high humidity.
(If it must be stored in a place of high humidity, insulate it from the outside and use a dehumidifying agent.)
 - Place of high temperatures (more than + 55 °C) and low temperatures (less than -25 °C).
 - Place where there are corrosive gases.
 - Place subjected to dripping water.
 - Place with a lot of dust.
 - Place with insufficient ventilation.
 - Place subjected to strong magnetic or electric fields.
 - Place subjected to radiation.

12.2 Storage of the STP Control Unit

If the STP control unit (including cables) is not used for a long period (more than a few months), follow the precautions below:

- 1) Store the STP control unit in a horizontal position.
- 2) DO NOT store the STP control unit in the following places:
 - Place of high humidity.
(If it must be stored in a place of high humidity, insulate it from the outside and use a dehumidifying agent.)
 - Place of high temperature (more than + 55 °C) and low temperature (less than - 25 °C) (excluding the battery).
 - Place subjected to direct sunlight.
 - Place where there are corrosive gases.
 - Place subjected to dripping water.
 - Place with a lot of dust.
 - Place of insufficient ventilation.
 - Place subjected to strong magnetic or electric field.
 - Place subjected to radiation.
 - Place subjected to mist.
 - Place with electric noise.
 - Place with vibration.

12.3 Disposal

Dispose of the STP pump and the STP control unit as **industrial waste** according to the guidelines given by each national and/or local government.



- ◇ When disposing of the STP pump, exhaust gases inside the STP pump thoroughly.
Residual gases may result in an accident when disposing of the STP pump.
If the STP pump has been used with reactive or corrosive gasses, always clean thoroughly before disposing of it to avoid any injury.
Confirm the characteristics of gas to be used, referring to the Material Safety Data Sheet (MSDS) you obtain from the gas supplier.



- ◇ BOC Edwards is not responsible for problems during or after disposal.

13 Specifications

13.1 Specifications for the STP Pump

Table 13.1 Specifications for the STP Pump

Item		H803 Series	H1303 Series
Flange size	Inlet port flange	VG150/ISO160	VG200/ISO200
	Outlet port flange	KF40	KF40
Pumping speed	N ₂ L/s	800	1300
	H ₂ L/s	600	1000
Compression ratio	N ₂	>10 ⁸	
	H ₂	10 ⁴	
Ultimate pressure	Pa (Torr)	10 ⁻⁷ (10 ⁻⁹) order (after baking)	
Maximum working pressure* ¹	Pa (Torr)	13.3 (0.1): Water cooling	
Allowable backing pressure* ¹	Pa (Torr)	270 (2): Water cooling	
Rated speed	rpm	32,500	
Starting time	min	7	
Stopping time	min	8	
Noise	dB	<50 (at 32,500 rpm)	
Baking temperature	°C	<120	
Lubricating oil		Not necessary	
Installation position		Free	
Cooling method		Water cooling	
Standard backing pump	L/min	>1,300	
Mass* ²	kg	39	
Dimensions	mm	Φ 270×H343(VG150) Φ 270×H350(ISO160F)	Φ 270×H312
Ambient temperature range	°C	0 to 40	
Storage temperature range	°C	- 25 to + 55	

The values shown in the table are typical.; They are not guaranteed.

*¹: The pressure is applicable under conditions that N₂ or other similar gas is vacuumed and the backing pump (pumping speed: 1,300 L/min) is used.

*²: Mass is a value of state that the only standard accessory was installed (except the optional accessory).

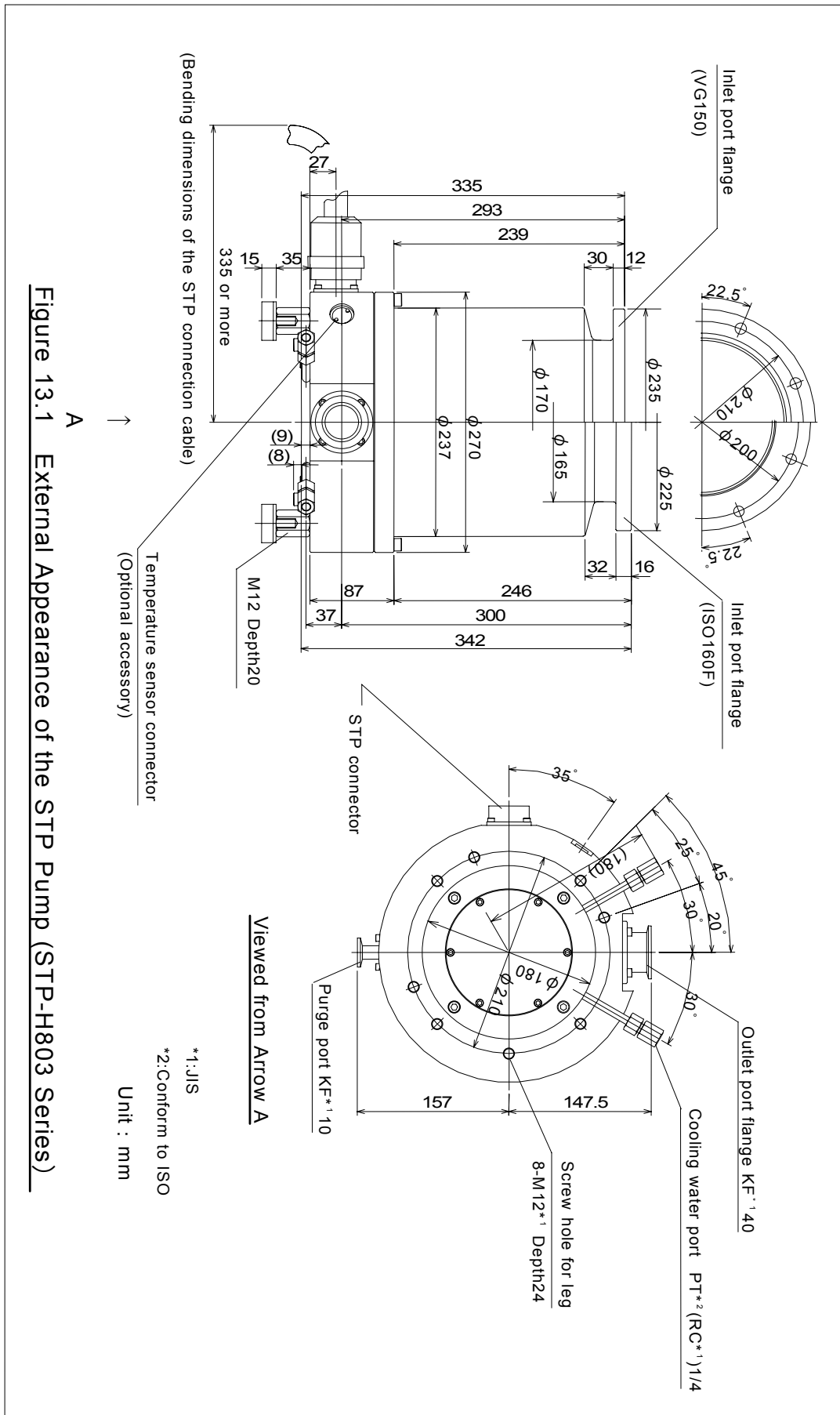

Figure 13.1 External Appearance of the STP Pump (STP-H803 Series)

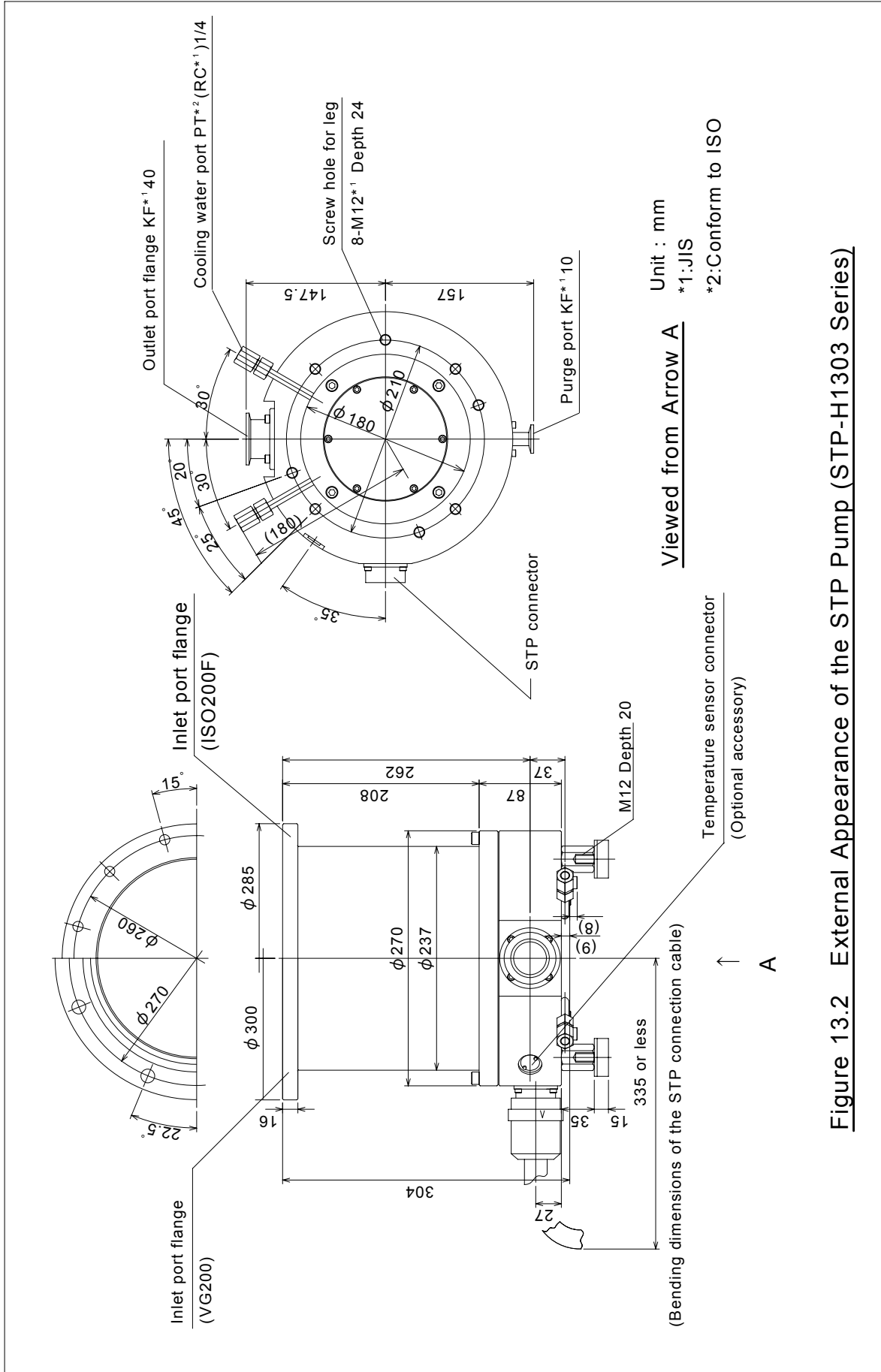

Figure 13.2 External Appearance of the STP Pump (STP-H1303 Series)

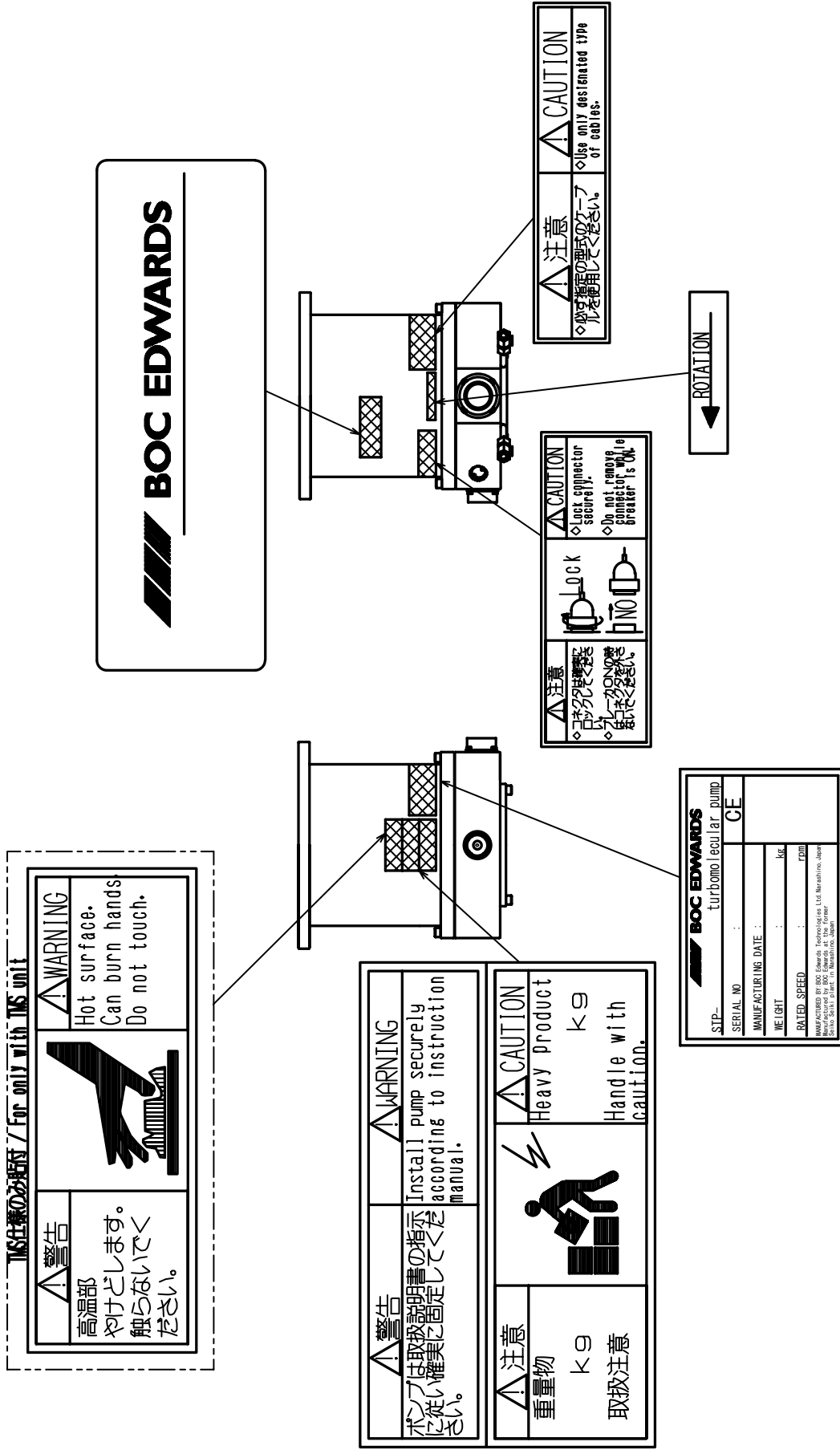

Figure 13.3 Label Affixing Positions for the STP Pump

13.2 Specifications for the STP Control Unit

Table 13.2 Specifications for the STP Control Unit (1/2)

Item		Specifications
Input voltage		V AC 200 to 240±10%
Input power	Without the TMS unit:	VA Max. 850
	With the TMS unit:	VA Max. 1,200
Input frequency		Hz 50/60±2
Leakage current value		mA Max. 3.5
Input phase		Single phase
Main breaker spec.	Rated current	A 15
	AIC: Ampere Interrupting Capacity	A 1000 (AC240V, 50/60Hz)
Motor drive system		3-phase DC brushless motor driver
Output voltage under rated operation		V AC 79
Output frequency under rated operation		Hz 542
Ambient temperature range		°C 0 to 40
Storage temperature range		°C - 25 to + 55
Mass* ¹		kg 9
Dimensions		mm W210 × H132.5 × D401.6
TMS control unit		Internal
Operation switches		<ul style="list-style-type: none"> ● START switch (flat panel switch, green) ● STOP switch (flat panel switch, dark gray) ● RESET switch (flat panel switch, gray) ● SELECT switch (flat panel switch, gray) ● UP switch (flat panel switch, gray) ● DOWN switch (flat panel switch, gray) ● ENTER switch (flat panel switch, gray) ● MANUAL/REMOTE changeover switch (slide switch, black)
Panel indication lamps		<ul style="list-style-type: none"> ● ACCEL lamp (green LED) ● NORMAL lamp (green LED) ● BRAKE lamp (green LED) ● TEMP CTRL lamp (green LED) ● POWER lamp (green LED) ● FAILURE lamp (red LED) ● REMOTE lamp (green LED)
Panel display		<ul style="list-style-type: none"> ● LCD panel (20 × 2 characters)

*¹ Mass is a value of state that the only standard accessory was installed (except the optional accessory).

Table 13.2 Specifications for the STP Control Unit (2/2)

Item	Specifications
Input/output terminals	<ul style="list-style-type: none"> ● AC POWER X2 (3 pins) ● P.CONNECTOR X1 (60 pins) ● TMS X5 (26 pins) ● REMOTE X7 (37 pins)
Input/output cables	<ul style="list-style-type: none"> ● Power (primary) cable ● STP connection cable ● TMS connection cable (optional accessory)
Safety functions	<ul style="list-style-type: none"> ● Magnetic bearing abnormality/error detection ● STP pump overheat detection ● Driver overload detection ● Power failure detection ● STP pump overspeed detection ● STP control unit overheat detection ● TMS unit failure detection ● Other TMS unit failure detection

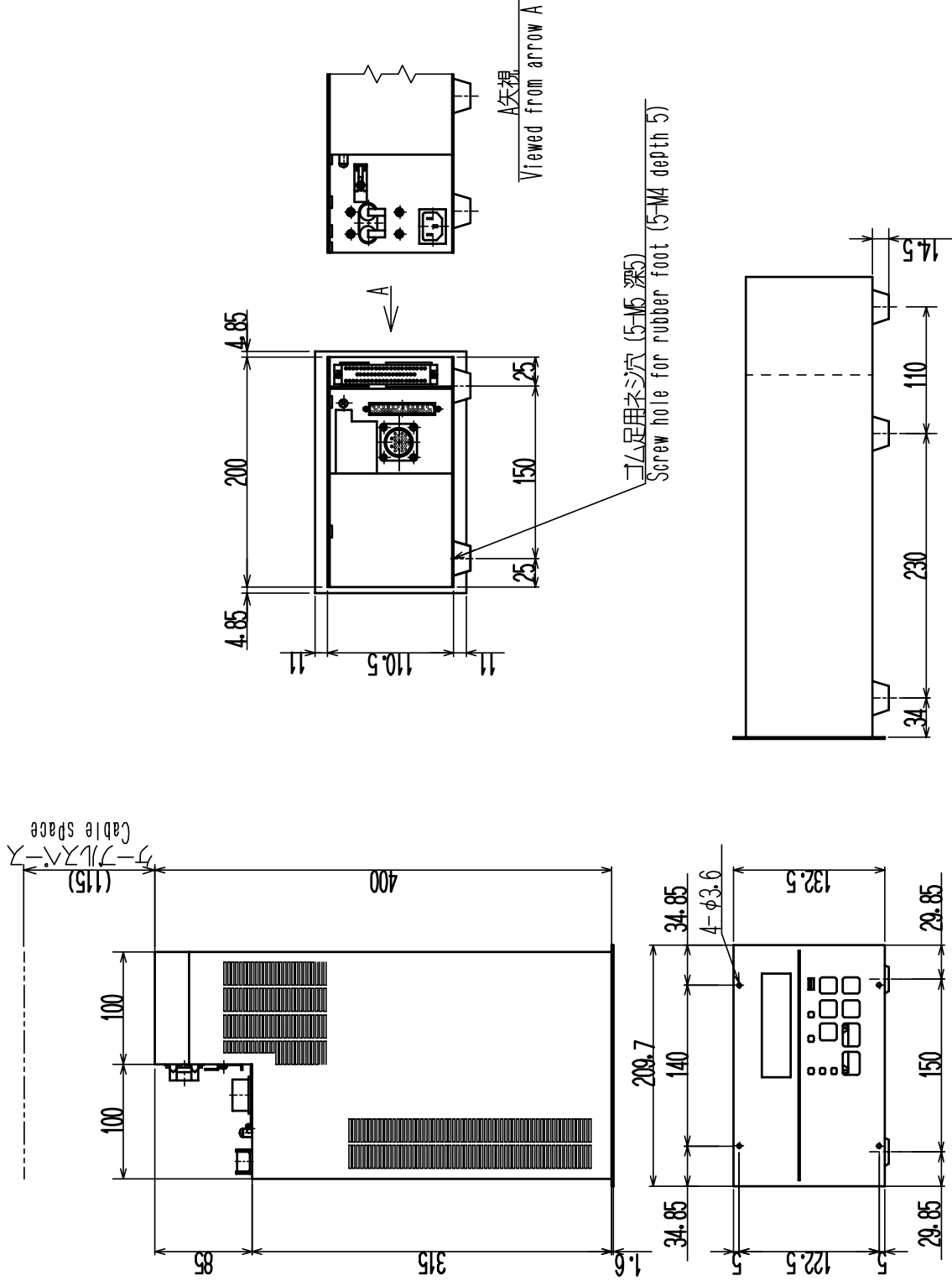

Figure 13.4 External Appearance of the STP Control Unit

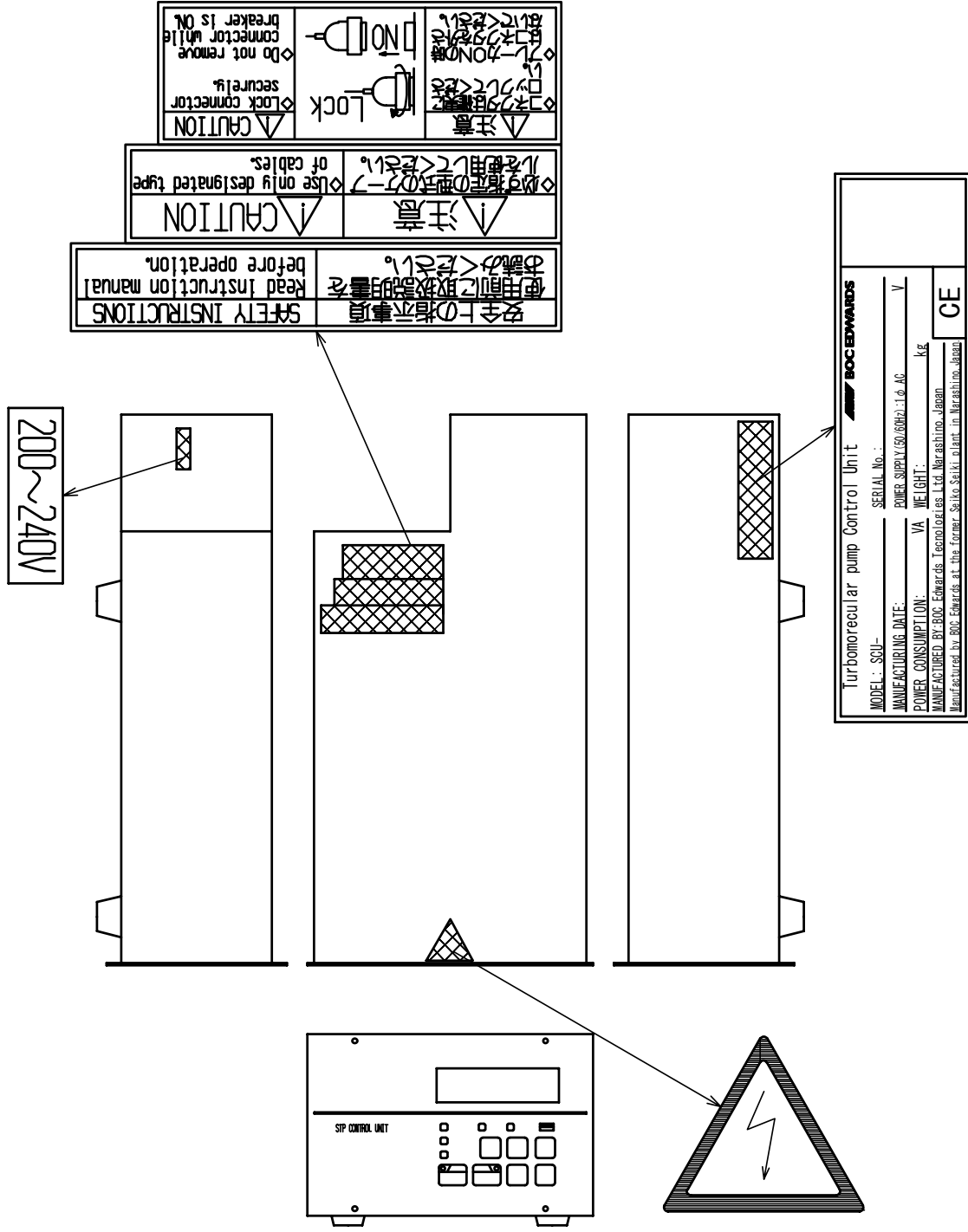

Figure 13.5 Label Affixing Positions for the STP Control Unit

UNIT CONVERSION TABLE

Length

m	cm	mm	inch
1	100	1.00×10^3	39.4
0.01	1	10.0	0.394
1×10^{-3}	0.10	1	39.4×10^{-3}
25.4×10^{-3}	2.54	25.4	1

Weight

g	kg	lb.
1	1.00×10^{-3}	2.20×10^{-3}
1×10^{-3}	1	2.20
454	0.454	1

Pressure

Pa	Torr	kgf/cm ²
1	7.50×10^{-3}	1.02×10^{-5}
133	1	1.36×10^{-3}
9.81×10^4	736	1

For more information, contact to the nearest Service Office.

Manufacture:

BOC Edwards Japan Limited

2-4-1, Shibakoen, Minato-ku, Tokyo 105-0011 JAPAN

Telephone:	Domestic	03-5470-6530
	International	+81-3-5470-6530
Facsimile:	Domestic	03-5470-6521
	International	+81-3-5470-6521

STP-H803C1
Turbomolecular Pump
INSTRUCTION MANUAL (excerpt)
(First Edition- c)

This Manual picks up the points of difference between the STP-H803/H1303 Series and the STP-H803C1. For the "Safety Precautions," installation, operation and maintenance, read the "STP-H803/H1303 Series Instruction Manual."

Keep this Manual in a place where you can quickly access it at any time.

INTRODUCTION

Thank you very much for purchasing BOC Edwards' turbomolecular pump. The turbomolecular pump is designed to be installed in the vacuum equipment to exhaust gases from it.

This manual covers all items necessary to ensure safe installation, operation and maintenance of the following series of the STP-H803C1 turbomolecular pump:

- | Model Name | Specification |
|--------------|---|
| • STP-H803C1 | High-throughput type, chemical specific ^{*1} |

For the specifications of other models of the STP-H803C1 pump, contact BOC Edwards.

In this manual, the above STP pump series is collectively referred to as the "STP pump."

This Manual picks up the points of difference between the STP-H803/H1303 Series and the STP-H803C1. For the "Safety Precautions," installation, operation and maintenance, read the "STP-H803/H1303 Series Instruction Manual."

The points of difference are as follows:

- **Rated speed:** 34,500r.p.m.
(Rated speed of STP-H803/H1303 Series is 32,500r.p.m.)

^{*1} Chemical specific: STP pump with anti-corrosive treatment (responding to chlorine, fluorine or other system gases)

TABLE OF CONTENTS

1	Specifications.....	1-1
1.1	Specifications for the STP Pump.....	1-1
1.2	Specifications for the STP Control Unit.....	1-2

TABLES

Table 1.1	Specifications for the STP Pump	1-1
Table 1.2	Specifications for the STP Control Unit.....	1-2

1 Specifications

1.1 Specifications for the STP Pump

Table 1.1 Specifications for the STP Pump

Item		STP-H803C1
Flange size	Inlet port flange	VG150/ISO160
	Outlet port flange	KF40
Pumping speed	N ₂ L/s	800
	H ₂ L/s	600
Compression ratio	N ₂	>10 ⁸
	H ₂	10 ⁴
Ultimate pressure	Pa (Torr)	10 ⁻⁷ (10 ⁻⁹) order (after baking)
Maximum working pressure* ¹	Pa (Torr)	13.3 (0.1): Water cooling
Allowable backing pressure* ¹	Pa (Torr)	270 (2): Water cooling
Rated speed	rpm	34,500* ²
Starting time	min	7
Stopping time	min	8
Noise	dB	<50 (at 34,500 rpm)
Baking temperature	°C	<120
Lubricating oil		Not necessary
Installation position		Free
Cooling method		Water cooling
Standard backing pump	L/min	>1,300
Mass* ³	kg	39
Dimensions	mm	270 × H343(VG150) 270 × H350(ISO160F)
Ambient temperature range	°C	0 to 40
Storage temperature range	°C	- 25 to + 55

The values shown in the table are typical.; They are not guaranteed.

*¹: The pressure is applicable under conditions that N₂ or other similar gas is vacuumed and the backing pump (pumping speed: 1,300 L/min) is used.

*²: The points of difference between the STP-H803/H1303 Series and the STP-H803C1.

*³: Mass is a value of state that the only standard accessory was installed (except the optional accessory).

STP-H803C1 Instruction Manual (excerpt)

1.2 Specifications for the STP Control Unit

Table 1.2 Specifications for the STP Control Unit (1/2)

Item		Specifications
Input voltage		V AC 200 to 240 ± 10%
Input power	Without the TMS unit:	VA Max. 850
	With the TMS unit:	VA Max. 1,200
Input frequency		Hz 50/60 ± 2
Leakage current value		mA Max. 3.5
Input phase		Single phase
Main breaker spec.	Rated current	15A
	AIC: Ampere Interrupting Capacity	1000A(AC240V, 50/60Hz)
Motor drive system		3-phase DC brushless motor driver
Output voltage under rated operation		V AC 79
Output frequency under rated operation		Hz 575*1
Ambient temperature range		°C 0 to 40
Storage temperature range		°C - 25 to + 55
Mass*2		kg 9
Dimensions		mm W210 × H132.5 × D401.6
TMS control unit		Internal
Operation switches		<ul style="list-style-type: none"> ● START switch (flat panel switch, green) ● STOP switch (flat panel switch, dark gray) ● RESET switch (flat panel switch, gray) ● SELECT switch (flat panel switch, gray) ● UP switch (flat panel switch, gray) ● DOWN switch (flat panel switch, gray) ● ENTER switch (flat panel switch, gray) ● MANUAL/REMOTE changeover switch (slide switch, black)
Panel indication lamps		<ul style="list-style-type: none"> ● ACCEL. lamp (green LED) ● NORMAL lamp (green LED) ● BRAKE lamp (green LED) ● TEMP CTRL lamp (green LED) ● POWER lamp (green LED) ● FAILURE lamp (red LED) ● REMOTE lamp (green LED)
Panel display		● LCD panel (20 × 2 characters)

*1 : The points of difference between the STP-H803/H1303 Series and the STP-H803C1.

*2 : Mass is a value of state that the only standard accessory was installed (except the optional accessory).

STP-H803C1 Instruction Manual (excerpt)

Table 1.2 Specifications for the STP Control Unit (2/2)

Item	Specifications
Input/output terminals	<ul style="list-style-type: none">● AC POWER X2 (3 pins)● P.CONNECTOR X1 (60 pins)● TMS X5 (26 pins)● REMOTE X7 (37 pins)
Input/output cables	<ul style="list-style-type: none">● Power (primary) cable● STP connection cable● TMS connection cable (optional accessory)
Safety functions	<ul style="list-style-type: none">● Magnetic bearing abnormality/error detection● STP pump overheat detection● Driver overload detection● Power failure detection● STP pump overspeed detection● STP control unit overheat detection● TMS unit failure detection● Other TMS unit failure detection

For more information, contact to the nearest Service Office.

Manufacture:

BOC Edwards Japan Limited

2-4-1, Shibakoen, Minato-ku, Tokyo 105-0011 JAPAN

Telephone:	Domestic	03-5470-6530
	International	+81-3-5470-6530
Facsimile:	Domestic	03-5470-6521
	International	+81-3-5470-6521

Return of BOC Edwards Equipment - Procedure

INTRODUCTION

Before returning your equipment, you must warn BOC Edwards if substances you used (and produced) in the equipment can be hazardous. This information is fundamental to the safety of our Service Centre employees and will determine the procedures employed to service your equipment.

Complete the Declaration (HS2) and send it to BOC Edwards before you dispatch the equipment. It is important to note that this declaration is for BOC Edwards internal use only, and has no relationship to local, national or international transportation safety or environmental requirements. As the person offering the equipment for shipment, it is your responsibility to ensure compliance with applicable laws.

GUIDELINES

- Equipment is '**uncontaminated**' if it has not been used, or if it has only been used with substances that are not hazardous. Your equipment is '**contaminated**' if it has been used with any substances classified as hazardous under EU Directive 67/548/EEC (as amended) or OSHA Occupational Safety (29 CFR 1910).
- If your equipment has been used with radioactive substances, biological or infectious agents, mercury, polychlorinated biphenyls (PCB's), dioxins or sodium azide, you must decontaminate it before you return it to BOC Edwards. You must send independent proof of decontamination (for example a certificate of analysis) to BOC Edwards with the Declaration (HS2). Phone BOC Edwards for advice.
- If your equipment is contaminated, you must either:
 - Remove all traces of contamination (to the satisfaction of laws governing the transportation of dangerous/hazardous substances).
 - Or, properly classify the hazard, mark, manifest and ship the equipment in accordance with applicable laws governing the shipment of hazardous materials.

Note: Some contaminated equipment may not be suitable for airfreight.

PROCEDURE

1. Contact BOC Edwards and obtain a Return Authorisation Number for your equipment.
2. Complete the Return of BOC Edwards Equipment - Declaration (HS2).
3. If the equipment is contaminated, you must contact your transporter to ensure that you properly classify the hazard, mark, manifest and ship the equipment, in accordance with applicable laws governing the shipment of contaminated/hazardous materials. As the person offering the equipment for shipment, it is your responsibility to ensure compliance with applicable law. **Note: Equipment contaminated with some hazardous materials, such as semiconductor by-products, may not be suitable for airfreight - contact your transporter for advice.**
4. Remove all traces of hazardous gases: pass an inert gas through the equipment and any accessories that will be returned to BOC Edwards. Where possible, drain all fluids and lubricants from the equipment and its accessories.
5. Seal up all of the equipment's inlets and outlets (including those where accessories were attached) with blanking flanges or, for uncontaminated product, with heavy gauge tape.
6. Seal equipment in a thick polythene/polyethylene bag or sheet.
7. If the equipment is large, strap the equipment and its accessories to a wooden pallet. If the equipment is too small to be strapped to a pallet, pack it in a suitable strong box.
8. Fax or post a copy of the Declaration (HS2) to BOC Edwards. The Declaration must arrive before the equipment.
9. Give a copy of the Declaration (HS2) to the transporter. You must tell your transporter if the equipment is contaminated.
10. Seal the original Declaration in a suitable envelope: attach the envelope securely to the outside of the equipment package, in a clear weatherproof bag.

WRITE YOUR RETURN AUTHORISATION NUMBER CLEARLY ON THE OUTSIDE OF THE ENVELOPE OR ON THE OUTSIDE OF THE EQUIPMENT PACKAGE.

Return of BOC Edwards Equipment - Declaration

Return Authorisation Number:

You must:

- Know about all of the substances which have been used and produced in the equipment before you complete this Declaration
- Read the Return of BOC Edwards Equipment - Procedure (HS1) before you complete this Declaration
- Contact BOC Edwards to obtain a Return Authorisation Number and to obtain advice if you have any questions
- Send this form to BOC Edwards before you return your equipment

SECTION 1: EQUIPMENT

Equipment/System Name _____

Part Number _____

Serial Number _____

Has the equipment been used, tested or operated ?

 YES Go to Section 2 NO Go to Section 4

IF APPLICABLE:

Tool Reference Number _____

Process _____

Failure Date _____

Serial Number of Replacement Equipment _____

SECTION 2: SUBSTANCES IN CONTACT WITH THE EQUIPMENT
Are any substances used or produced in the equipment:

- Radioactive, biological or infectious agents, mercury, poly chlorinated biphenyls (PCBs), dioxins or sodium azide? (if YES, see Note 1) YES NO
- Hazardous to human health and safety? YES NO

Note 1 : BOC Edwards will not accept delivery of any equipment that is contaminated with radioactive substances, biological/infectious agents, mercury, PCB's, dioxins or sodium azide, unless you:

- Decontaminate the equipment
- Provide proof of decontamination

YOU MUST CONTACT BOC EDWARDS FOR ADVICE BEFORE YOU RETURN SUCH EQUIPMENT

SECTION 3: LIST OF SUBSTANCES IN CONTACT WITH THE EQUIPMENT

Substance name	Chemical Symbol	Precautions required (for example, use protective gloves, etc.)	Action required after a spill, leak or exposure

SECTION 4: RETURN INFORMATION

Reason for return and symptoms of malfunction _____

- If you have a warranty claim:
- who did you buy the equipment from ? _____
 - give the supplier's invoice number _____

SECTION 5: DECLARATION

Print your name: _____ Print your job title: _____

Print your organisation: _____

Print your address: _____

Telephone number: _____ Date of equipment delivery: _____

I have made reasonable enquiry and I have supplied accurate information in this Declaration. I have not withheld any information, and I have followed the Return of BOC Edwards Equipment - Procedure (HS1).

Note: Please print out this form, sign it and return the signed form as hard copy.

Signed: _____ Date _____

UNITED KINGDOM**CORPORATE HEADQUARTERS****BOC EDWARDS**

Manor Royal
Crawley
West Sussex
RH10 9LW
Tel +(44) 1293 528844
Fax +(44) 1293 533453

BOC EDWARDS

Wingates Industrial Estate
Great Bank Road
Westhoughton, Bolton
Lancashire
BL5 3SL
Tel +(44) 1942 652652
Fax +(44) 1942 652651

AMERICA (USA)**USA HEADQUARTERS****BOC EDWARDS**

One Edwards Park
301 Ballardvale Street
Wilmington, MA 01887
Tel +(1) 978 658 5410
Toll free (USA only) 1 800 848 9800
Fax +(1) 978 658 7969

3901 Burton Drive
Santa Clara, CA 95054
Tel +(1) 408 496 1177
Fax +(1) 408 496 1188

1810 West Drake Drive
Suite 101
Tempe, AZ 85283
Tel +(1) 602 777 7007
Fax +(1) 602 777 2244

11701 Stonehollow Drive
Suite 100
Austin, TX 78758
Tel +(1) 512 491 6622
Fax +(1) 512 491 0629

3501 Island Avenue
Philadelphia, PA 19153
Tel +(1) 215 365 8653
Fax +(1) 978 753 6846

BELGIUM**BOC EDWARDS**

Bergensesteenweg 709
B1600 Sint-Pieters-Leeuw
Brussels
Tel +(32) 2 363 0030
Fax +(32) 2 363 0064

BRAZIL**BOC DO BRASIL LTDA
DIVISÃO EDWARDS ALTO VACO**

Rua Bernardo Wrona 222
02710 São Paulo-SP
Tel +(55) 11 3952 5000
Fax +(55) 11 3965 2766

CANADA**BOC EDWARDS**

5975 Falbourne Street
Mississauga, Ontario L5R3W6
Canada
Tel +(1) 905 501 2558
Fax +(1) 905 501 1632

12055 Cote de Liesse
Dorval, Quebec H9P1B4
Canada
Tel +(1) 514 631 3501
Fax +(1) 514 631 3502

CHINA**BOC TRADING
(SHANGHAI) CO. LTD.**

23 Fu Te Road (N)
Wai Gao Qiao Free Trade Zone
Pudong
Shanghai, 200131
PRC China
Tel +(86 21) 5866 9618
Fax +(86 21) 5866 9993

FRANCE**BOC EDWARDS**

125 Avenue Louis Roche
92238 Gennevilliers, Cedex
Paris
Tel +(33) 1 47 98 24 01
Fax +(33) 1 47 98 44 54

GERMANY**BOC EDWARDS**

Ammerthalstraße 36
85551 Kirchheim
Munich
Tel +(49) 89 99 19 18 0
Fax +(49) 89 99 19 18 99

HONG KONG S.A.R.**BOC EDWARDS (ASIA)**

12 Chun Yat Street
Tseung Kwan O Industrial Estate
Tseung Kwan O, Kowloon
Hong Kong S.A.R.
Tel +(852) 2372 2640
Fax +(852) 2796 9095

INDIA**BOC EDWARDS**

DIVIN. OF BOC INDIA LIMITED
203 Surya Kiran Building
19 Kasturba Gandhi Marg
New Delhi - 110 001
India
Tel +(91) 11 851 0065
Fax +(91) 11 851 0245

ISRAEL**EDWARDS ISRAEL VACUUM LTD.**

5 Habarzel Blvd
Gat 2000 Industrial Zone
Qiryat Gat 82000
Tel +(972) 8 681 0633
Fax +(972) 8 681 0640

ITALY**BOC EDWARDS**

Via Carpaccio 35
20090 Trezzano sul Naviglio
Milan
Tel +(39) 02 48 4471
Fax +(39) 02 48 401638

JAPAN**HEADQUARTERS****BOC EDWARDS**

Shuwa Shiba Park Building A-3F
2-4-1 Shibakoen Minato-ku
Tokyo, 105-0011
Tel +(81) (0) 3 5470 6530
Fax +(81) (0) 3 5470 6521

KOREA**HEADQUARTERS****SONGWON EDWARDS LTD.**

5th FL. Daewoo Engineering Bldg.
Soonae-dong
Bundang-gu, Sungnam City
Kyungki-do, Korea
Tel +(82) 31 716 7070
Fax +(82) 31 738 1001-3

FACTORY & GV**SONGWON EDWARDS LTD.**

625-7 Upsong-dong
Chunan City
Chungchong Nam-do
Korea
Tel +(82) 41 621 7070
Fax +(82) 41 621 7700

SINGAPORE**BOC EDWARDS (ASIA)**

42 Loyang Drive
Loyang Industrial Estate
Singapore 508962
Tel +(65) 6546 8408
Fax +(65) 6546 8407

TAIWAN, R.O.C.**EDWARDS TECHNOLOGIES
LIMITED**

No. 434 Chung hua Road
Toufen Town, Miaoli County
Taiwan ROC
Tel +(886) 37 611422
Fax +(886) 37 611401

PLEASE CONTACT ANY OF THESE COMPANIES FOR DETAILS OF OTHER SALES AND SERVICE CENTRES IN YOUR AREA.

BOC Edwards is part of BOC Limited. BOC Edwards and the stripe symbol are trade marks of The BOC Group.

© BOC Edwards 2003

Produced by Technical Publicity Techpublicity@edwards.boc.com

<http://www.bocedwards.com>
info@bocedwards.com

 **BOC EDWARDS**