



# Varian SH-100

## Technical Specifications

	SH-100 Dry Scroll Single Hermetic Vacuum Pump
Peak pumping speed	50 Hz: 83 L/m, 5 m <sup>3</sup> /hr (2.9 cfm) 60 Hz: 100 L/m, 6 m <sup>3</sup> /hr (3.5 cfm) See Figure 2 on page 17 for details
Media	No toxic, corrosive, explosive or particulate forming gases
Ultimate pressure	5.0 × 10 <sup>-2</sup> Torr (6.6 × 10 <sup>-2</sup> mbar)
Maximum inlet pressure	1.0 atmosphere (0 psig)
Maximum outlet pressure	1.5 atmosphere (7.5 psig)
Inlet connection	NW25
Exhaust connection	Female 1/4" National Pipe Thread (NW16 adapter provided)
Gas ballast	Female 1/8" National Pipe Thread, (20 micron sintered plug provided)
Ambient operating temperature	5 °C to 40 °C (41 °F to 104 °F)
Storage temperature	-20 °C to 60 °C (-4 °F to 140 °F)
Motor rating	0.5 HP (0.37 kW)
Operating voltages	1 phase/50-60 Hz/100-115:200-230 VAC
Run current	See Table 3 on page 20
Motor thermal protection	Type U automatic
Operating speed	60 Hz: 1725 RPM, 50 Hz: 1425 RPM
Cooling system	Air-cooled
Weight	Pump only: 19.1 kg (42 lbs) Shipping weight: 20 kg (44 lbs)
Leak rate (with exhaust sealed)	<1 × 10 <sup>-7</sup> sccs helium
Noise Level (per ISO 11201)	56 dB(A)
Vibration level at inlet (per ISO 10816-1)	Class 1B, 1.5 mm/s
Fuse type	M5 × 20 mm, 10 A, Slo-Blo, Littelfuse Model H215010 or equivalent
Hour meter	Integral Hour Meter provided, displays running time to closest .1 hour
Conformance standards	Conforms to SEMI S2-0200 and applicable UL, C-UL, and CE standards.



# PROVAC

## SALES

PHONE: 831-462-8900

FAX: 831-462-3536

WWW.PROVAC.COM

## Varian SH-100

### Pumping Curves

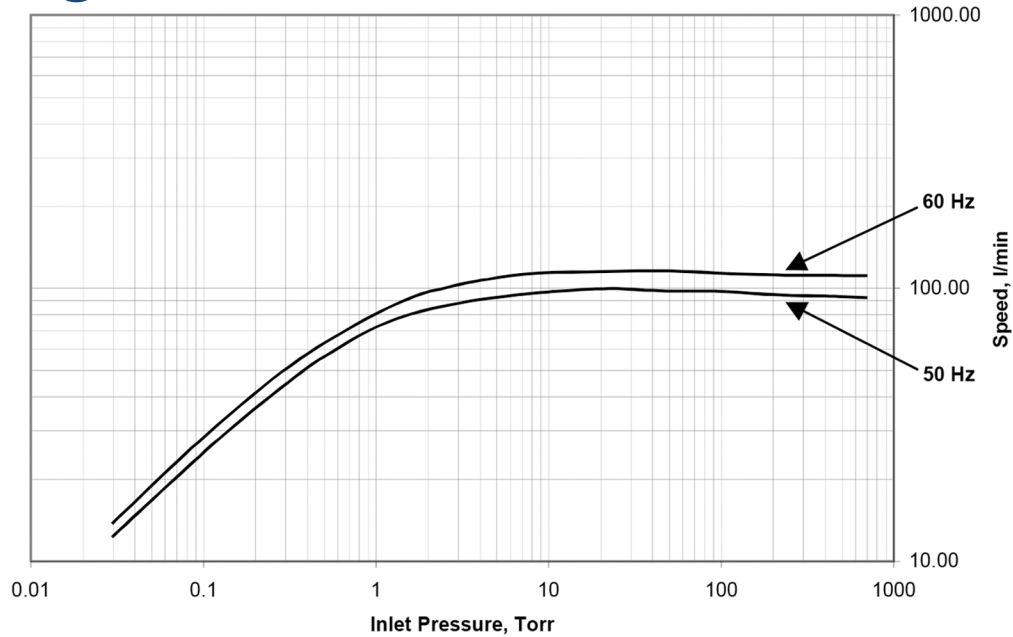

### Dimensions

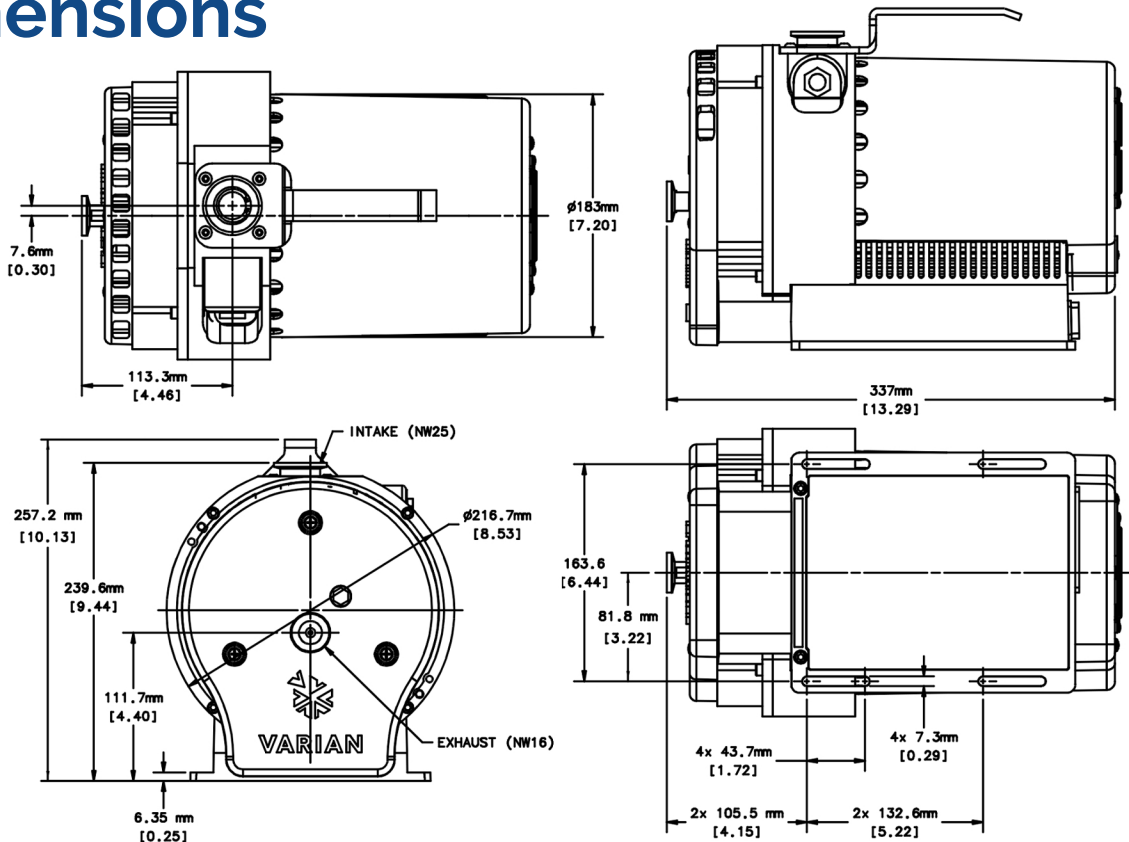



**PROVAC**  
SALES

PHONE: 831-462-8900

FAX: 831-462-3536

WWW.PROVAC.COM

## Varian SH-100

### Features & Benefits

- designed for easy integration into OEM systems
- built-in exhaust valve for low noise production
- automatic air ballast for effective handling of moisture
- quick tip-seal replacement for low cost of ownership
- high pumping speed at high pressure
- low weight with convenient carrying handle
- built-in fail-safe isolation valve
- low temperature operation



### Applications

- scanning electron microscopes • laboratory • load locks • transfer chambers • beam lines • drying ovens • cryogenics • manufacturing
- glove box • backing pump • leak detection