



PROVAC

SALES

PHONE: 831-462-8900

FAX: 831-462-3536

WWW.PROVAC.COM

Edwards QDP-40, QDP-80

Technical Specifications

	QDP40	QDP80 (4 kW and 6 kW)
Mass	172 kg	202 kg
Motor rating	2.2 kW	4 kW/6 kW
Warm-up time to nominal performance	15 min	15 min
Inlet connections	ISO40	ISO63
Outlet connections	NW40	NW40
Vacuum system maximum leak-rate	1×10^{-5} mbar.l.s ⁻¹ (1×10^{-3} Pa.l.s ⁻¹)	1×10^{-5} mbar.l.s ⁻¹ (1×10^{-3} Pa.l.s ⁻¹)
Exhaust system maximum leak-rate	1×10^{-5} mbar.l.s ⁻¹ (1×10^{-3} Pa.l.s ⁻¹)	1×10^{-5} mbar.l.s ⁻¹ (1×10^{-3} Pa.l.s ⁻¹)
Ambient operating temperature range	5 to 40 °C	5 to 40 °C
Maximum ambient operating humidity	90% RH	90% RH
Protection degree (as defined by IEC 529)	IP44	IP44
Continuous A-weighted sound pressure level (at 1 meter)	< 70 dB(A)	< 70 dB(A)

Performance data

Typical peak pumping speed		
50 Hz	44 m ³ h ⁻¹	80 m ³ h ⁻¹
60 Hz	55 m ³ h ⁻¹	96 m ³ h ⁻¹
Displacement (swept volume)		
50 Hz	52 m ³ h ⁻¹	91.5 m ³ h ⁻¹
60 Hz	62.4 m ³ h ⁻¹	109.8 m ³ h ⁻¹
Typical ultimate vacuum without gas-ballast		
50 Hz	5×10^{-2} mbar (5×10^0 Pa)	3×10^{-2} mbar (3×10^0 Pa)
60 Hz	3×10^{-2} mbar (3×10^0 Pa)	3×10^{-2} mbar (3×10^0 Pa)



PROVAC

SALES

PHONE: 831-462-8900

FAX: 831-462-3536

WWW.PROVAC.COM

Edwards QDP-40, QDP-80 Pumping Curves

QDP-40

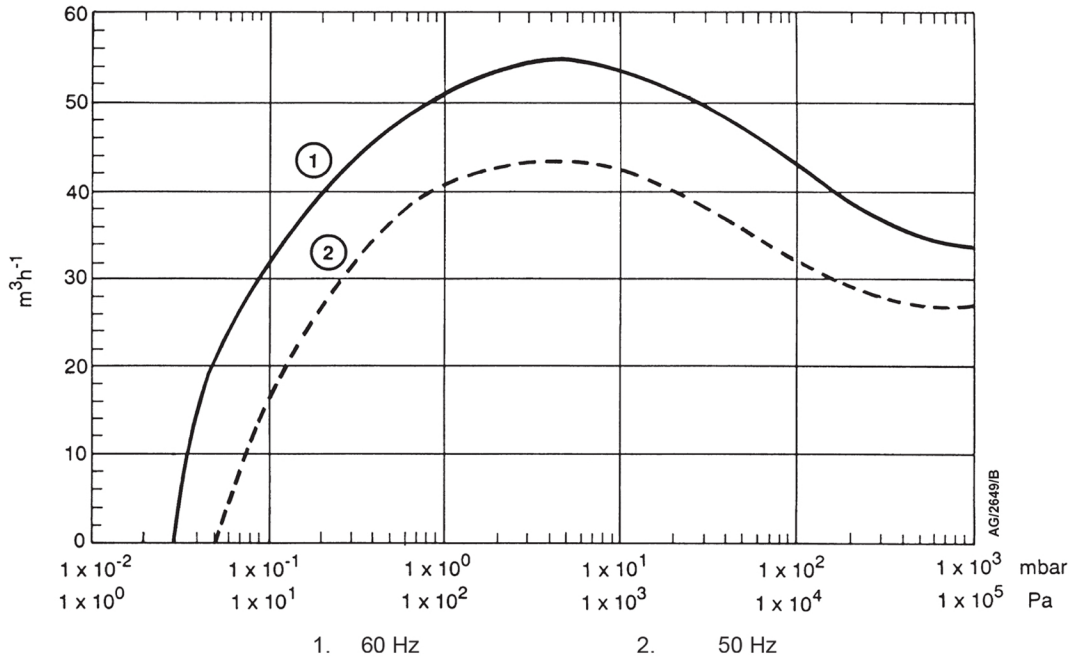

QDP-80

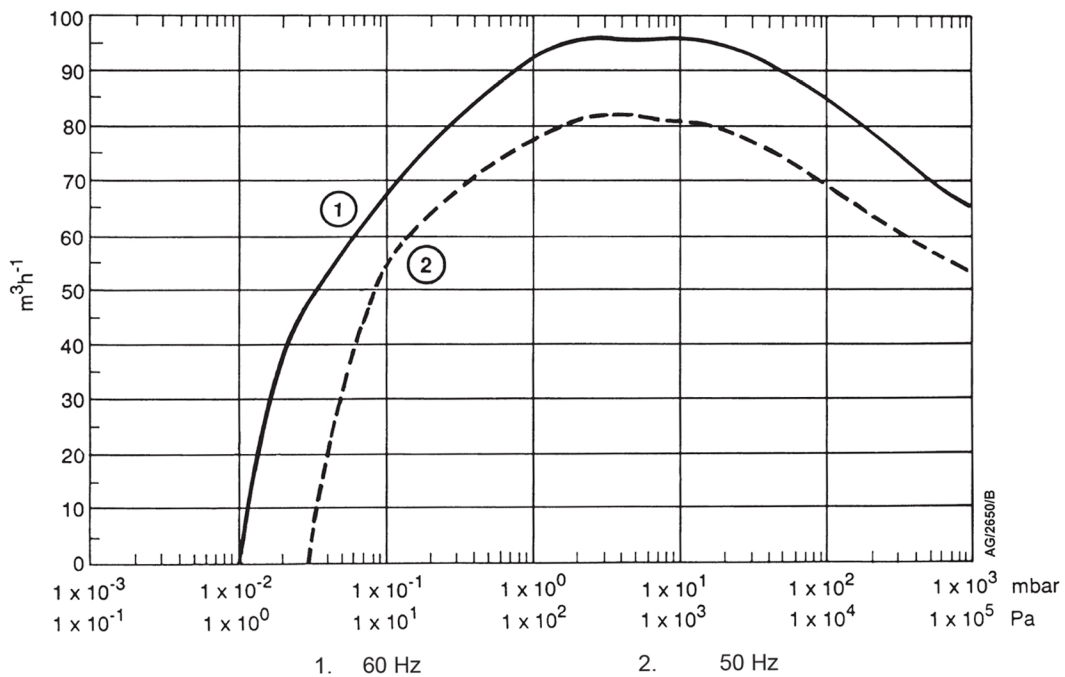



PROVAC

SALES

PHONE: 831-462-8900

FAX: 831-462-3536

WWW.PROVAC.COM

Edwards QDP-40, QDP-80

Dimensions

QDP-40

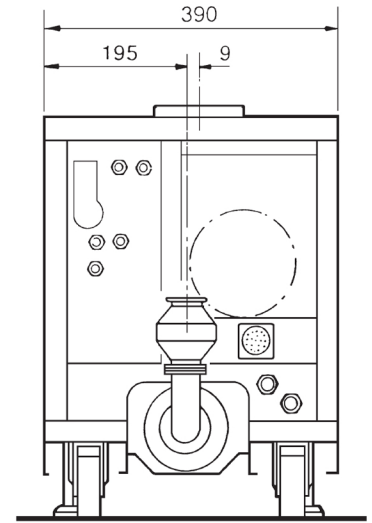
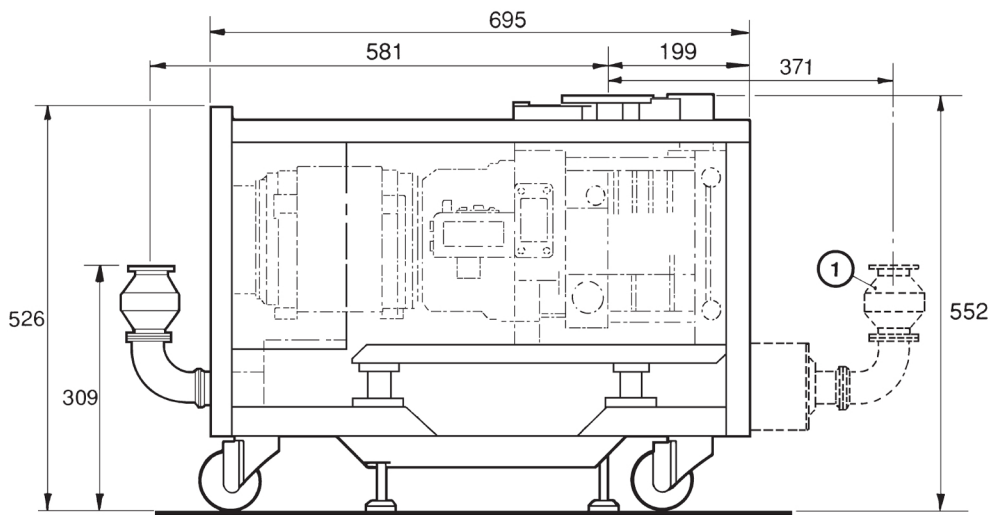

QDP-80

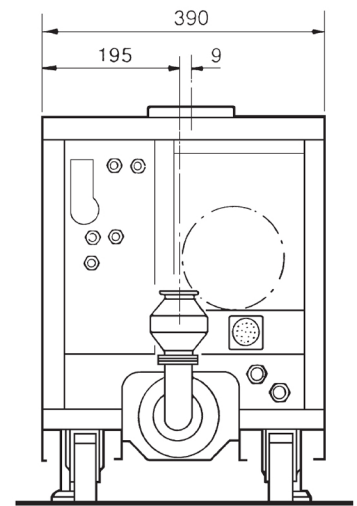
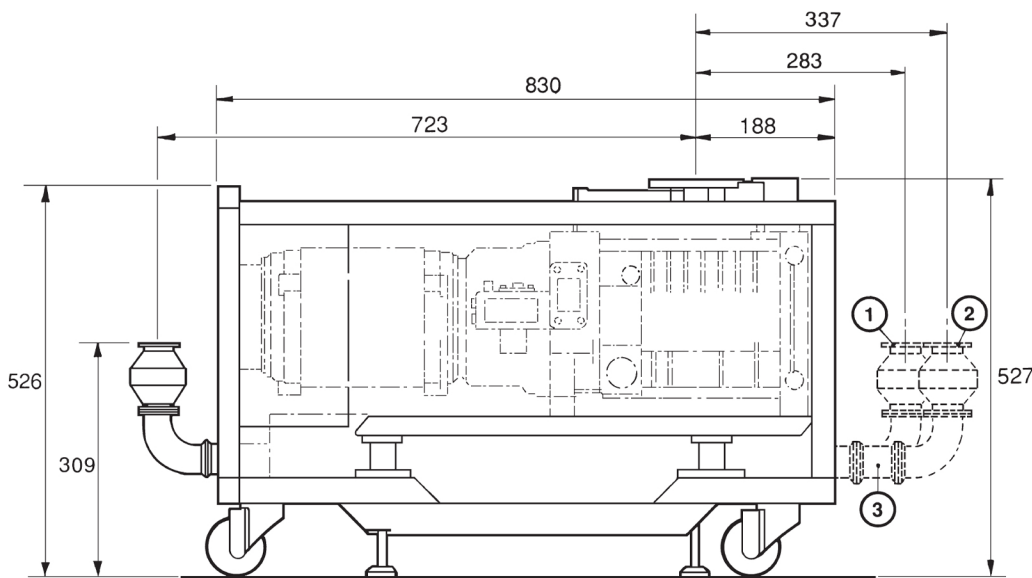



PROVAC

SALES

PHONE: 831-462-8900

FAX: 831-462-3536

WWW.PROVAC.COM

Edwards QDP-40, QDP-80

Features & Benefits

- proven performance & high reliability in demanding applications
- patented rotor arrangement gives high volumetric efficiency with low power input
- short & simple gas path maximizes internal conductance & minimizes dead space
- no intercoolers needed
- low operating costs
- clean vacuum, no backstreaming
- designed for low maintenance
- intrinsically non-polluting

Applications

- semiconductor processing • freeze drying • vacuum deposition
- research & development • sputtering • load lock chambers
- vacuum furnaces • chemical processes • ion implanters
- plasma etch • LPCVD

