



TPS 110 - 400 / TPS 111 - 401

Mains pack

Operating Instructions

Table of contents

1	About this manual	3
	1.1 Validity	3
	1.2 Conventions	3
2	Safety	5
	2.1 Safety precautions	5
	2.2 Proper use	6
	2.3 Improper use	6
3	Product description	7
	3.1 Product identification	7
	3.2 Function	7
4	Installation	8
	4.1 Range of application	8
	4.2 Assembly	8
	4.3 Connecting to the mains power supply	9
5	Operation	9
	5.1 Switching on	9
	5.2 Switching off	9
6	Service	10
7	Accessories	10
8	Technical data	10
	8.1 Dimensions	11
	Declaration of conformity	12

1 About this manual

1.1 Validity

This operating manual is for customers of Pfeiffer Vacuum. It describes the functioning of the designated product and provides the most important information for safe use of the unit. The description follows applicable EU guidelines. All information provided in this operating manual refers to the current state of the product's development. The documentation remains valid as long as the customer does not make any changes to the product.

Up-to-date operating instructions can also be downloaded from www.pfeiffer-vacuum.com.

1.2 Conventions

Safety instructions

The safety instructions in Pfeiffer Vacuum operating instructions are the result of risk evaluations and hazard analyses and are oriented on international certification standards as specified by UL, CSA, ANSI Z-535, SEMI S1, ISO 3864 and DIN 4844. In this document, the following hazard levels and information are considered:

DANGER
<p>Imminent danger Indicates an imminent hazardous situation that will result in death or serious injury.</p>
WARNING
<p>Possibly imminent danger Indicates an imminent hazardous situation that can result in death or serious injury.</p>
CAUTION
<p>Possibly imminent danger Indicates an imminent hazardous situation that can result in minor or moderate injury.</p>
NOTICE
<p>Command or note Command to perform an action or information about properties, the disregarding of which may result in damage to the product.</p>

Pictographs



Prohibition of an action or activity in connection with a source of danger, the disregarding of which may result in serious accidents



Warning of a displayed source of danger in connection with operation of the unit or equipment



Command to perform an action or task associated with a source of danger, the disregarding of which may result in serious accidents



Important information about the product or this document

Instructions in the text

→ Work instruction: here you have to do something.

Abbreviations used

TC: Electronic drive unit for turbopump

TPS: Mains pack

2 Safety

2.1 Safety precautions



Duty to inform

Each person involved in the installation or operation of the unit must read and observe the safety-related parts of these operating instructions.

→ The operator is obligated to make operating personnel aware of dangers originating from the unit or the entire system.



WARNING

Danger of unsafe electrical installation

Safe operation after installation is the responsibility of the operator.

- Do not independently modify or change the pump and electrical equipment.
- Make sure that the system is integrated in an emergency off safety circuit.
- Consult Pfeiffer Vacuum for special requirements.



WARNING

Danger due to lack of power disconnection device as defined in SEMI-S2

Pump and electronic drive unit are not equipped with a power disconnection device. Installation of a user-supplied power disconnection device in accordance with SEMI-S2.

→ Fit a circuit breaker with an interruption rating of min. 10,000 A.



WARNING

Danger of electric shock

In case of defect, the parts connected to the mains supply are under voltage.

→ Always keep the mains connection freely accessible so you can disconnect it at any time.

- Observe the safety and accident prevention regulations.
- Check regularly that all safety precautions are being complied with.
- Do not loosen any plug connection during operations.
- Keep leads and cables well away from hot surfaces (> 70 °C).
- Always ensure a safe connection to the protective earthing conductor (PE, protection class I).
- The unit has been accredited with protection class IP 20. Take necessary measures when installing into ambient conditions, which afford other protection classes.
- Before carrying out any work disconnect the unit and all associated installations safely from the mains.

2.2 Proper use



NOTICE

EC conformity

The manufacturer's declaration of conformity becomes invalid if the operator modifies the original product or installs additional components.

→ Following installation into a plant and before commissioning, the operator must check the entire system for compliance with the valid EU directives and reassess it accordingly.



WARNING

Observe the device properties!

Due to their design and their protection class IP 20, the devices are designated to the installation into closed systems.

→ Take appropriate measures (e.g. covers) to ensure that no external moisture can attain to electric devices and equipment.

→ Take appropriate measures to ensure that hot surfaces (>70 °C) can not be touched.

→ External separators shall be provided in case of not approachable installed devices.



- Pfeiffer Vacuum mains packs only serve to the external voltage supply of Pfeiffer Vacuum turbopumps with integrated electronic drive unit.

- Only operate Pfeiffer Vacuum power supplies in the available specification.

2.3 Improper use

Improper use will cause all claims for liability and warranties to be forfeited. Improper use is defined as usage for purposes deviating from those mentioned above, especially:

- connection to pumps or units which are not suitable for this purpose according to their operating instructions
- connection to units which have exposed voltage-carrying parts

3 Product description

3.1 Product identification

Product characteristics

Type TPS	110	111	180	181	310	311	400	401
Type of attachment	W ¹⁾	E ²⁾	W	E	W	E	W	E
Electronic drive unit	TC 110		TC 110		TC 400		TC 400	
Output power	110 W		180 W		300 W		400 W	

¹⁾ W = Wall or standard rail mounting

²⁾ E = 19" partial plug-in unit 3HE with front panel

To correctly identify the product when communicating with Pfeiffer Vacuum, always have the information from the rating plate available.

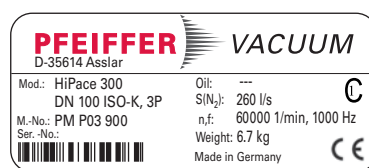

Fig. 1: Example for a rating plate

Scope of delivery

- Mains pack TPS
- Installation fittings
- Operating instructions

3.2 Function

TPS mains packs provide Pfeiffer Vacuum turbopumps featuring TC electronic drive unit with voltage. The output voltage "DC out" is securely separated from the power input voltage "AC in".

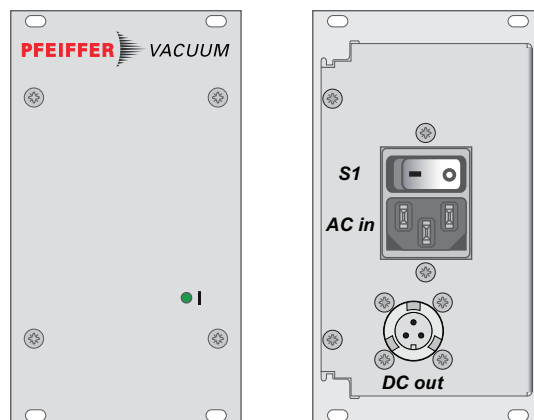

Fig. 2: Front and rear view of a TPS mains pack

S1 Switch ON/OFF
AC in Mains connection
DC out Connection TM 700

4 Installation

4.1 Range of application

Pfeiffer Vacuum power supplies TPS must be installed and operated in the following ambient conditions.

Permissible protection class	IP 20
Temperature	+5 °C to +50 °C
Relative air humidity	max. 80%, at T ≤ 31 °C, max. 50% at T ≤ 40 °C
Air pressure:	770 hPa - 1060 hPa

4.2 Assembly

The specific type designation of the mains pack provides information on the installation type (see p. 7, chap. 3.1). Installation fittings included.



NOTICE

Ensure free convection

Incorrect installation can cause damage by over-heating or create a fire hazard.

- Maintain a minimum distance of 50 mm from cooling vents to adjacent components or boundaries.
- Install device perpendiculary.



WARNING

Risk of short circuit

The use of screws that are longer than those stated below can cause a short circuit and is not permitted.

- To ensure the safe installation of Pfeiffer Vacuum products, use only the installation materials supplied.

Standard rail installation

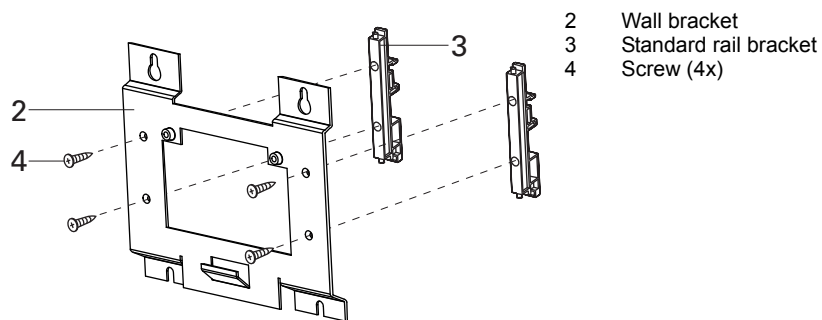

- Fasten standard rail bracket onto the wall bracket using the screws supplied.

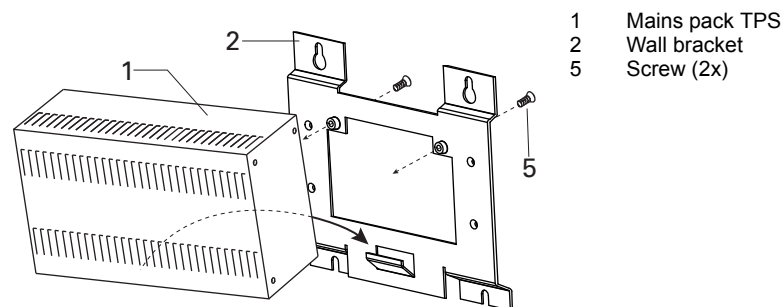

- Insert the mains pack in the lower clip of the wall bracket (with standard rail brackets) and fix it using the screws supplied.

- Attach the mains pack to the standard rail.

Wall installation

- Insert the mains pack in the lower clip of the wall bracket (without standard rail brackets) and fix it using the screws supplied.
- Attach the mains pack to the wall.

Install in a rack as a 19" module

- Push mains pack into a rack and fasten.
 - To ensure adequate convection, observe the perpendicular mounting.

4.3 Connecting to the mains power supply



WARNING

Danger of unsafe electrical installation

Safe operation after installation is the responsibility of the operator.

- Do not independently modify or change the pump and electrical equipment.
- Make sure that the system is integrated in an emergency off safety circuit.
- Consult Pfeiffer Vacuum for special requirements.

- Order the mains cable separately (see "accessories").
- Switch off switch S1 on the power pack (position "0").
- Plug mains cable into the mains connection "AC in".
- Connect the mains cable to the mains.
- Always ensure a safe connection to the protective earthing conductor (PE, protection class I).

5 Operation

5.1 Switching on

- Establish connection between the mains pack and electronic drive unit in accordance with the operating manual for the turbopump.
- Switch on power supply using switch S1 on the mains pack.
 - The green LED on the front panel displays the device function.

5.2 Switching off

- Switch off switch S1 on the power pack (position "0").

6 Service

Pfeiffer Vacuum offers first-class service!

- Fast replacement with exchange products in mint condition
- Advice on the most cost-efficient and quickest solution

Detailed information, addresses and forms at: www.pfeiffer-vacuum.com (Service).

Service orders

All service orders are carried out exclusively according to our repair conditions for vacuum units and components.

7 Accessories

Designation	
Mains cable 230 V AC with safety plug, Euro socket C13 (straight), 3 m	P 4564 309 ZA
Mains cable 115 V AC with UL plug, Euro socket C 13 (straight), 3 m	P 4564 309 ZE
Mains cable 208 V AC with UL plug, Euro socket C 13 (straight), 3 m	P 4564 309 ZF

8 Technical data

Parameter	TPS 110, TPS 111	TPS 180, TPS 181
Ambient temperature	5-50 °C	5-50 °C
Protection category	IP 20	IP 20
Mains requirement: frequency (range)	50/60 Hz	50/60 Hz
Mains requirement: power consumption	130 VA	210 VA
Mains requirement: voltage (range)	115-230 (-20-+15 %) V AC	115-230 (-20-+15 %) V AC
Output voltage	24 (± 2 %) V DC	24 (± 2 %) V DC
Output current	4.6 A	7.5 A
Weight	0.7 kg	1.0 kg

Parameter	TPS 310, TPS 311	TPS 400, TPS 401
Ambient temperature	5-50 °C	5-50 °C
Protection category	IP 20	IP 20
Mains requirement: frequency (range)	50/60 Hz	50/60 Hz
Mains requirement: power consumption	340 VA	450 VA
Mains requirement: voltage (range)	115-230 (-20-+15 %) V AC	115-230 (-20-+15 %) V AC
Output voltage	24 (± 2 %) V DC	48 (± 2 %) V DC
Output current	12.5 A	8.4 A
Weight	1.1 kg	1.75 kg

8.1 Dimensions

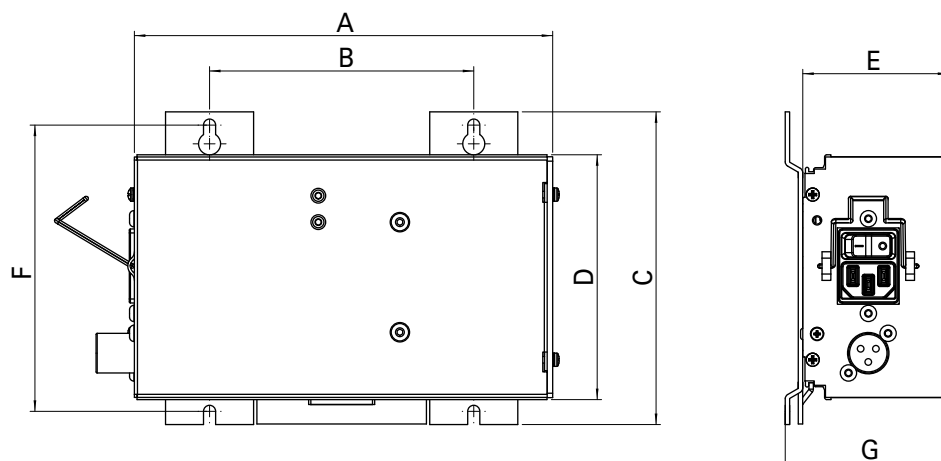

Fig. 3: Power supply for wall or standard-rail mounting

Dimensions	TPS 110	TPS 180	TPS 310	TPS 400
A	169 mm	190 mm	190 mm	190 mm
B	120 mm	120 mm	120 mm	120 mm
C	142 mm	142 mm	142 mm	142 mm
D	111.2 mm	111.2 mm	111.2 mm	111.2 mm
E	48.7 mm	58.4 mm	67.3 mm	104.6 mm
F	130 mm	130 mm	130 mm	130 mm
G	56.6 mm	66.5 mm	75.3 mm	112.5 mm

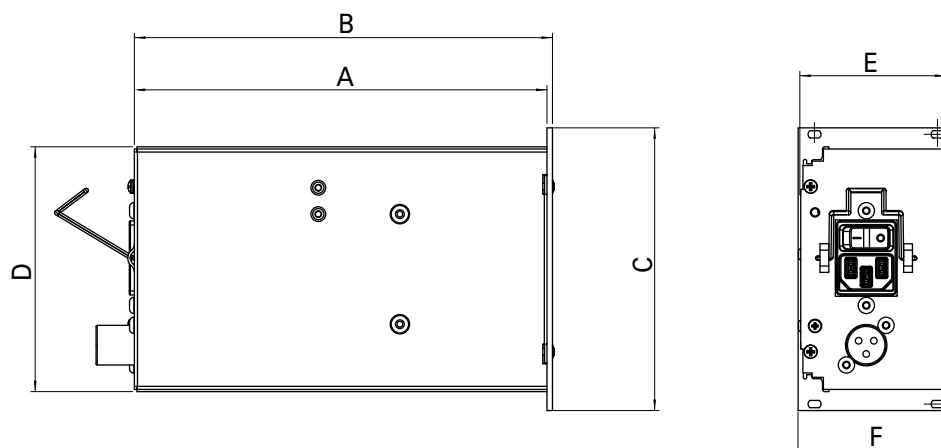

Fig. 4: Mains pack as 19" partial plug-in 3HU with front plate

Dimensions	TPS 111	TPS 181	TPS 311	TPS 401
A	161.5 mm	187.5 mm	187.5 mm	187.5 mm
B	164 mm	190 mm	190 mm	190 mm
C	128.4 mm	128.4 mm	128.4 mm	128.4 mm
D	111.2 mm	111.2 mm	111.2 mm	111.2 mm
E	48.7 mm	58.4 mm	67.3 mm	104.6 mm
F	50.5 mm	60.7 mm	70.8 mm	106.4 mm



Declaration of conformity

We hereby declare that the product cited below satisfies all relevant provisions according to the following **EC directives**:

- **Electromagnetic Compatibility 2004/108/EC**
- **Low Voltage 2006/95/EEC**

TPS

Harmonised standards and national standards and specifications which have been applied:

DIN EN 61000-3-2 : 2008
DIN EN 61000-3-3 : 2006
DIN EN 61010-1 : 2010
DIN EN 61326-1 : 2006
DIN EN 62061 : 2005

Signatures:

Pfeiffer Vacuum GmbH
Berliner Straße 43
35614 Asslar
Germany

(M. Bender)
Managing Director

(Dr. M. Wiemer)
Managing Director

CE/2013

**Vacuum solutions
from a single source**

Pfeiffer Vacuum stands for innovative and custom vacuum solutions worldwide, technological perfection, competent advice and reliable service.

**Complete range
of products**

From a single component to complex systems: We are the only supplier of vacuum technology that provides a complete product portfolio.

**Competence in
theory and practice**

Benefit from our know-how and our portfolio of training opportunities! We can support you with your plant layout and provide first-class on-site-service worldwide.

**Are you looking for a
perfect vacuum solution?
Please contact us**

Pfeiffer Vacuum GmbH
Headquarters • Germany
T +49 6441 802-0
info@pfeiffer-vacuum.de