

Translation of the Original Operating Instructions

UnoLine™

DuoLine™

Rotary Vane Pumps



UNO/DUO 35/65

UNO/DUO 35/65 M

DUO 35/65 C/MC

Table of contents

1	About this manual	3
1.1	Validity	3
1.2	Conventions	3
2	Safety	5
2.1	Safety precautions	5
2.2	Proper use	5
2.3	Improper use	6
3	Transport and storage	6
3.1	Transport	6
3.2	Storage	6
4	Product description	7
4.1	Product identification	7
4.2	Construction and function	8
5	Installation	9
5.1	Setting up the pump	9
5.2	Connecting the vacuum side	9
5.3	Connecting the exhaust side	10
5.4	Connecting to the mains power supply	10
5.5	Filling up the operating fluid	13
5.6	Operations monitoring (option)	14
6	Operation	15
6.1	Before switching on the pump	15
6.2	Switching on the pump	15
6.3	Pumping condensable vapours	15
6.4	Switching off the pump	17
7	Maintenance	18
7.1	Precautions	18
7.2	Changing the operating fluid	19
7.3	Cleaning the gas ballast valve	21
7.4	Cleaning and setting the silencer	23
7.5	Checking the oil level in the oiler (only for C version pumps)	23
8	Decommissioning	24
8.1	Shutting down for longer periods	24
8.2	Restarting the pump	24
8.3	Disposal	24
9	Malfunctions	25
9.1	Troubleshooting	26
10	Service	27
11	Spare parts	28
11.1	Spare parts packages	29
12	Accessories	30
13	Technical Data	31
13.1	Dimension diagram	32

1 About this manual

1.1 Validity

This operating manual is for customers of Pfeiffer Vacuum. It describes the functioning of the designated product and provides the most important information for safe use of the unit. The description follows applicable EU guidelines. All information provided in this operating manual refer to the current state of the product's development. The documentation remains valid as long as the customer does not make any changes to the product.

Up-to-date operating instructions can also be downloaded from www.pfeiffer-vacuum.net.

Applicable documents

UNO/DUO 35/65	Operating instructions
Safety information for vacuum pumps "Safety Guide"	PT 0300 BN*
Declaration of Conformity	Part of this document
Operating instructions for accessories (order-specifically)	see section "accessories"*

*also available via www.pfeiffer-vacuum.net

1.2 Conventions

Safety instructions

The safety instructions in Pfeiffer Vacuum operating manuals are the result of risk evaluations and hazard analyses and are oriented on international certification standards as specified by UL, CSA, ANSI Z-535, Semi-S1, ISO 3864 and DIN 4844. In this document, the following hazard levels and information are considered:

DANGER
Immediate danger Death or very severe injuries occur.
WARNING
Possible danger Death or injuries may occur.
CAUTION
Possible danger Medium to slight injuries may occur.
NOTE
Command or note Command to perform an action or information about properties, the disregarding of which may result in damage to the product.

Pictograph definitions



Prohibition of an action or activity in connection with a source of danger, the disregarding of which may result in serious accidents.



Warning of a displayed source of danger in connection with operation of the unit or equipment.



Command to perform an action or task associated with a source of danger, the disregarding of which may result in serious accidents.

Instructions in the text

→ Work instruction: here you have to do something.

Abbreviations used

C version: Corrosive gas version

M version: Version with magnetic coupling

MC version: C-Version with magnetic coupling

Symbols used

The following symbols are used consistently throughout in all illustrations:

- ① Vacuum flange
- ⊙ Exhaust flange
- ⓐ Gas ballast valve
- ⚡ Power connection

2 Safety

2.1 Safety precautions



NOTE

Duty to inform

Each person involved in the installation, operation or maintenance of the vacuum pump must read and observe the safety-related parts of these operating instructions.

- Absolute observe the safety information for vacuum pumps (PT 0300 BN) !
- The operator is obligated to make operating personnel aware of dangers originating from the vacuum pump, the pumped medium and the entire system.

- Do not expose any body parts to the vacuum.
- Observe the safety and accident prevention regulations.
- Check regularly that all safety precautions are being complied with.
- Do not carry out any unauthorised modifications or conversions to the pumps.
- Depending on the operating and ambient conditions, the surface temperature of the pumps may rise above 70 °C. Use suitable finger guards if necessary.
- When returning the pump to us please note the instructions in the Service section.

The following safety instructions are only valid for the disassembly of the drive system for a vacuum pump with a magnetic coupling:

- When disassembling the drive system from the pump housing, the strong magnetic field may influence the function and operational reliability of electrical and electronic devices.
- Persons with cardiac pacemakers must keep away from the magnetic coupling. Danger to life!
- Disassembled magnetic couplings must be kept away from computers, data storage media and other electronic components.
- Keep the disassembled components of the magnetic coupling separate at all times. Danger of crushing!
- Do not allow any magnetised parts into the vicinity of the magnetic coupling. Danger of injury!

2.2 Proper use



NOTE

CE conformity

The manufacturer's declaration of conformity becomes invalid if the operator modifies the original product or installs additional components.

- Following installation into a plant and before commissioning, the operator must check the entire system for compliance with the valid EU directives and reassess it accordingly.

- The vacuum pump may only be used to generate a vacuum.
- Installation, operating and maintenance regulations must be complied with.
- Using accessories not mentioned in this manual is not permitted without authorisation from Pfeiffer Vacuum.

2.3 Improper use

Improper use will cause all claims for liability and guarantees to be forfeited. Improper use is deemed to be all use for purposes deviating from those mentioned above, especially:

- Pumping of corrosive gases (with exception of corrosiv gas versions).
- Pumping of explosive media.
- Operation of the pump in potentially explosive areas.
- Pumping of gases containing impurities such as particles, dusts and condensate; note the vapour compatibility levels of the pump.
- Pumping of substances that tend to sublime.
- Use of the vacuum pump to generate pressure.
- Pumping of liquids.
- The use of operating fluids not specified by Pfeiffer Vacuum.
- Connection to pumps or units which are not suitable for this purpose according to their operating instructions.
- Connection to units which have touchable and voltage carrying parts.

3 Transport and storage

3.1 Transport

Transport instructions

- Remove the locking cap from the vacuum and exhaust flange immediately before connecting!
 - Check the cone strainer, paying attention to the o-ring.
- Use only the crane eye on the top side of the pump to lift the pump.

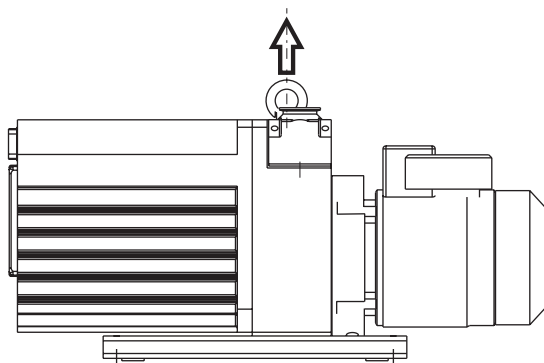

Fig. 1: Transporting the pump

3.2 Storage

- Check that all the openings on the pump are securely closed.
- Store the pump in a cool, dry place; preferably at room temperature (approx. 20°C).
 - For a longer period of storage, seal the pump in a PE bag with drying agents enclosed.
 - For a period of storage longer than one year, it is recommended to carry out maintenance and change the operating fluid.

4 Product description

4.1 Product identification

To ensure reliable identification of the product, always keep all of the information on the rating plate to hand, and use it when communicating with Pfeiffer Vacuum:

- Pump model and model number
- Serial number
- Type and quantity of the operating fluid
- Date of manufacture

For motor-specific data, please see the separately installed motor rating plate.

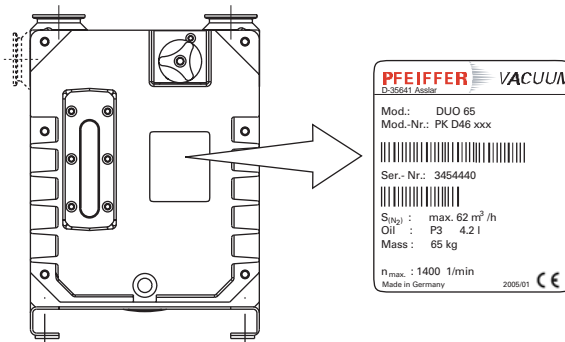

Fig. 2: Product identification on the rating plate

Scope of delivery

- Pump with motor (power cord/power switch --> dependent on the motor type)
- Operating fluid P3 (for standard pump)
- Cone strainer and centering ring with O-ring
- Locking cap for vacuum and exhaust flange
- Operating instructions

Differences between the pump typ

Pump type	Pump versions
UNO/DUO 35/65	Standard version of pump
DUO 35/65 C	C version of pump; differences from the standard version: <ul style="list-style-type: none"> • Operating fluid F5 • Vane material changed • Gas ballast valve with dosable flushing gas connection • Leak rate $\leq 1 \cdot 10^{-5}$ mbar * l/s
UNO/DUO 35/65 M	M version of pump; differences from the standard version: <ul style="list-style-type: none"> • Magnetic coupling at the pump system • Leak rate $\leq 1 \cdot 10^{-5}$ mbar * l/s
DUO 35/65 MC	MC version of pump; differences from the standard version: <ul style="list-style-type: none"> • Operating fluid F5 • Vane material changed • Gas ballast valve with dosable flushing gas connection • Magnetic coupling at the pump system • Oiler for the shaft feed through • Leckrate $\leq 1 \cdot 10^{-5}$ mbar * l/s

4.2 Construction and function

The UnoLine™/DuoLine™ pumps are oil sealed, single-/two-stage rotary vane pumps with air cooling and pressure oil lubrication and suitable for many coarse and fine vacuum applications. The pumps are equipped with a vacuum safety valve that vacuum seals the vacuum chamber and vents the pump at the same time when the pump is at a standstill. The pump version with magnetic coupling is not subject to any mechanical wear, and is thus maintenance-free.

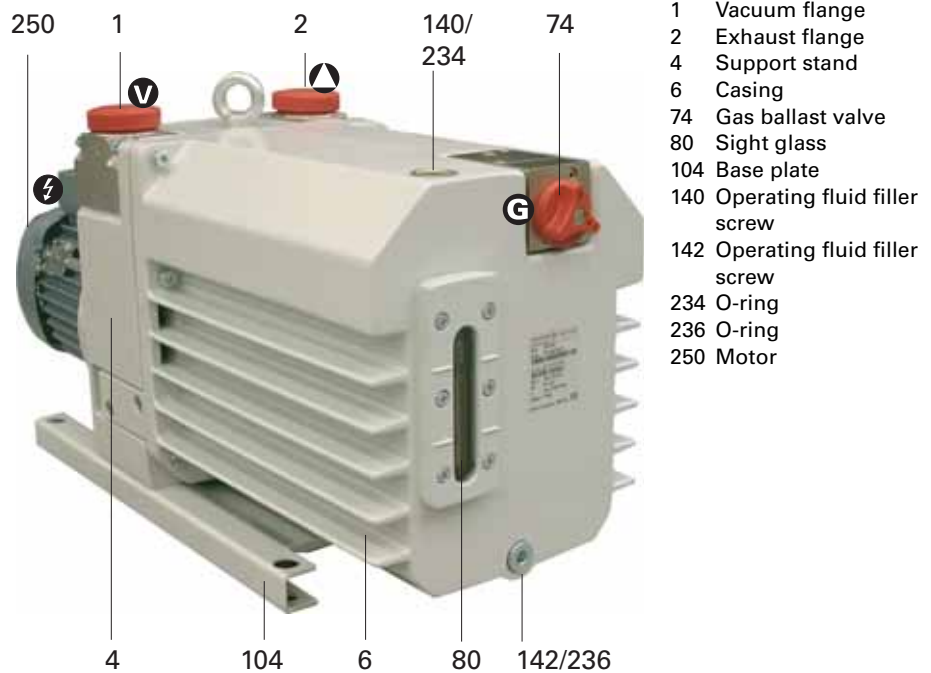

Fig. 3: Rotary vane pump UNO/DUO 35/65

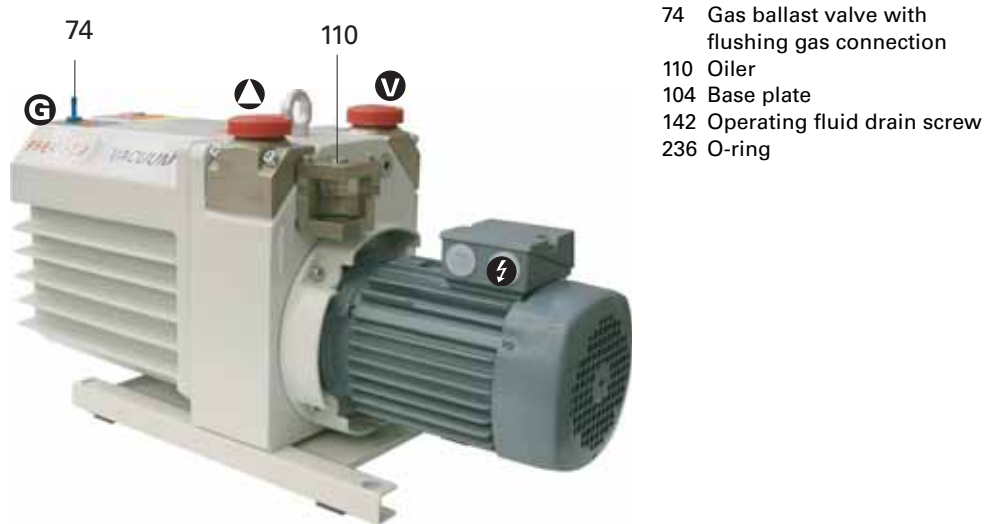

Fig. 4: Rotary vane pump DUO 35/65 C

5 Installation

5.1 Setting up the pump

Installation location Observe the following requirements when setting up the pump:

- Note the load-bearing capacity of the mounting surface.
- Maximum installation altitude 2000 m (above mean sea level)
- Permissible ambient temperature: +12 ... +40°C
- Maximum relative humidity 85%

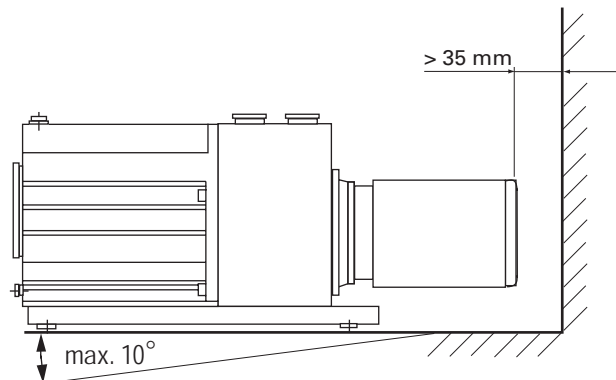

Fig. 5: Setting up

- Fill up with operating fluid before operating the first time (see p. 13, chap. 5.5).
 - Amount and type according to rating plate
- Always place the pump on a firm, even surface.
 - Where stationary installation is involved, anchor the pump on site.
- When installing the pump in a closed housing, ensure there is sufficient air circulation.
 - Sightglass and gas ballast valve must be visible and readily accessible.
 - Voltage and frequency information given on the motor rating plate must be visible.

5.2 Connecting the vacuum side

- Before attaching the piping at the vacuum flange remove locking cap and insert protective strainer with the respective O-ring.
- The connection between the pump and the recipient should be kept as short as possible.
 - Depending on the pump type, use metallic hoses or PVC hoses with flange connections.
 - Separators, filters etc. may be installed upstream to protect the pump (see accessories). However, please observe the loss of pumping capacity due to the conductivity of the accessories.

If a protective strainer is inserted into the intake port, the suction capacity loss is negligible.

5.3 Connecting the exhaust side



CAUTION

High pressure in the exhaust line!

Danger of damage to the seals and danger of the pump bursting.

- Install the line without shut-off valves on the exhaust side.
- If there is danger of a build-up of excess pressure (> 1500 mbar abs.) in the lines, observe all official accident prevention safety regulations.
- If the exhaust gases are being extracted, the exhaust pressure must be at least 250 mbar greater than the pressure at the intake side.

- Choose the cross-section of the exhaust line to be at least the size of the nominal connection diameter of the vacuum pump's exhaust connection.
- Piping to the pump must be suspended or supported.
 - Forces from the piping system must not be allowed to act on vacuum pumps.
- Lay piping from the pump, sloping downward so that no condensate can flow back into the pump; otherwise fit a condensate separator.
 - If an air trap is created in the system then a device for draining condensation water must be provided at the lowest point.



WARNING

Emission of toxic substances from the exhaust!

Danger of poisoning from emitted gases or vapours, which can be detrimental to health and/or can pollute the environment, depending on the particular application.

- Comply with the applicable regulations when working with toxic substances.
- Only officially approved filter systems may be used to separate out these substances.

5.4 Connecting to the mains power supply

Depending on the pump type, different motor versions are possible:

- Three phase motor without switch and mains cable (with 3 PTC).
- Three phase motor with switch and mains cable (without 3 PTC).



CAUTION

Excess voltage!

Danger of destroying the motor.

- Power connections must comply with local regulations. Voltage and frequency information given on the motor rating plate must correspond to the mains voltage and frequency values.
- To protect the motor and supply cable in case of malfunction, mains fuse protection must be implemented.



WARNING

Danger of injury from moving parts!

After power failure or motor shutdown due to overheating, the motor may restart automatically.

- Secure the motor so that it cannot be switched on while any work is being performed on the pump.
- If necessary, dismantle the pump from the installation for inspection.



NOTE

The transmission power of the pump's magnetic coupling is so great that there is no overload protection for the motor.

Three phase motor

Inspection of the direction of rotation

With pumps with three-phase motors is it necessary to check the direction of rotation!



CAUTION

Operating fluids may leak out!

If the direction of rotation is incorrect, there is a danger that operating fluids may leak at the vacuum flange.

→ Always check the direction of rotation before filling in operating fluid.

- Remove the locking cap from the exhaust flange (if existing).
- Switch the pump on briefly (from 2 to 3 sec.).
 - The motor and motor fan must turn in a clockwise direction (see the arrow on the support stand).
- If the direction of rotation is incorrect: Swap two phase contacts at the connecting cable.
- Fill up the operating fluid.

Motor protection

Pump motors equipped with PTC temperature sensors (3PTC) in the stator windings can be connected to a PTC resistor tripping device for protection against overload.

Tripping devices store the shutdown event and need to be manually switched back on again via the integrated RESET button or via the external RESET S3. Mains-ON is detected as an automatic RESET. Other approved motor temperature monitoring can be used also by the operator.

→ Set up the connections so that the directional rotation indicated on the pump is maintained, regardless of the representations in the current flow diagram.

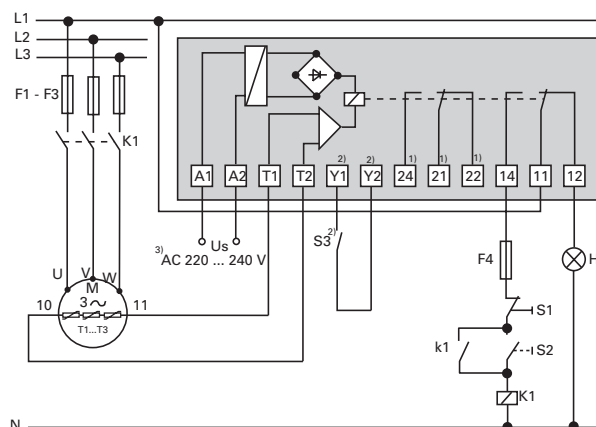

- U₅ Control voltage
- S₁ OFF button
- S₂ ON button
- S₃ RESET button, external
- K1 Contactor
- F1 ... F4 Fuses
- T1... T3 PTC resistor sensor
- H1 Tripping indicator
- M Motor, 3-phase

1) Only for devices with two relay outputs
 2) Only for MSR type
 3) Only for order no.: P 4768 051 FQ

Fig. 6: Connection example for a three-phase AC motor with PTC resistor tripping device

On site fuse protection with current circuit-breaker

valid for motor version without switch/with 3PTC

Depending on the process conditions and the intake pressure, the motor can become overloaded, i.e. the power input can exceed I_N . In cyclical operation, it is permissible for the current to temporarily exceed the rated current I_N by 15%, provided that the motor temperature is monitored by means of a thermistor.

Fuse protection with preset circuit-breaker in terminal box

valid for motor version with switch/without 3PTC

Operating conditions that exceed the rated current I_N for longer periods can trigger the current circuit-breaker. In this case monitoring with a PTC temperature sensor (3PTC) is not possible.

The Three Phase Current Motor Circuit

Delta Connection

The three coils are connected in series with the connection point connected to the mains. The voltage of each coil is the same as the mains voltage whereas the mains current is the cube root of the coil current. Delta connections are denoted by the symbol Δ . The voltage between the mains supply lines is called mains voltage. The mains current is the current which flows in the supply lines.

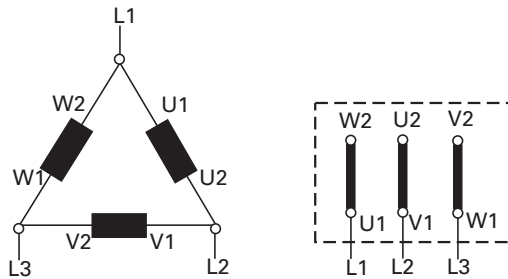

Fig. 7: Motor coil and connecting plate of Delta Connection

Star Connection

The ends of the three coils are connected at the star center. The terminal voltage is the cube root of the coil voltage; the mains and the coil current are the same. Star connections are denoted by the symbol \mathbf{Y} . A star connection three phase motor for 400 V mains voltage has a coil voltage of 230 V.

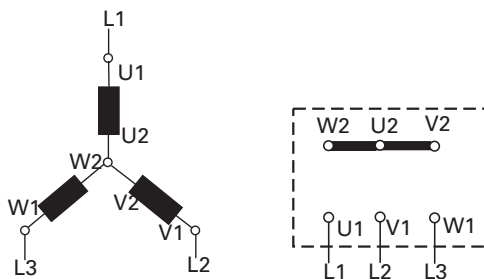

Fig. 8: Motor coil and connecting plate of Star Connection

5.5 Filling up the operating fluid

The type and amount of operating fluid should be visible on the pump's rating plate for every rotary vane pump.

The delivery consignment for the **standard pump** contains sufficient operating fluid for one filling. Pumps for special applications (e.g. for pumping corrosive gases) can be operated with other operating fluids. These must be defined in accordance with Pfeiffer Vacuum specifications before initial assembly and ordered separately.

Permissible operating fluids

- P3 (Standard operating fluid)
- F5 (Operating fluid for corrosive gas versions)
- D1 (for special applications and higher operating temperature)
 - Final pressure of measurement, depending on the type of gas: $< 5 \cdot 10^{-2}$ mbar



NOTE

Guarantees relating to attainment of final pressures and trouble free functioning of the pump apply only providing one of the permissible operating fluids is used.

Filling up the operating fluid

- Unscrew operating fluid filler screw.
- Fill up operating fluid.
 - Correct filling level during operations: Within the markings at the sightglass frame.

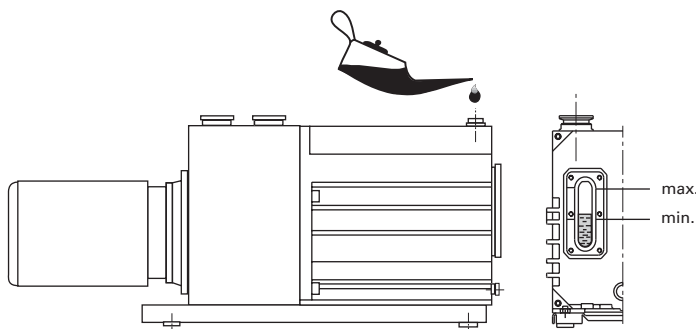

Fig. 9: Filling up the operating fluid

- Screw in operating fluid filler screw 140.
- Check operating fluid level only when the pump is warm and running; close
 - vacuum flange and gas ballast valve to do so.
 - Check operating fluid daily in non-stop operation, otherwise whenever the pump is switched on. Refilling is possible when the pump is in final vacuum operation.



WARNING

Toxic vapours!
 Danger of poisoning when igniting and heating synthetic operating fluids (e.g. F4/F5) above 300°C.

- Observe the application instructions of the operating fluid manufacturer.
- Do not allow operating fluid to make contact with tobacco products; observe safety precautions when handling chemicals.

5.6 Operations monitoring (option)

A pressure switch can be installed on the side of the support to monitor the oil pressure of the rotary vane pump during operations. By pressure drop and when the pump is at rest, the contact of the pressure switch opens. The signal can be used to control external valves:

Switching voltage:	5 ... 250 Volt (potential free)
Maximum current:	2 Amp.
Protection type:	IP 55

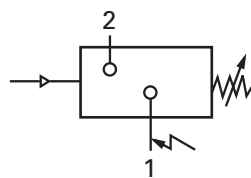

1 + 2 NO switches = open without pressure

Fig. 10: Circuit diagram, pressure switch for operating fluid monitoring

6 Operation

6.1 Before switching on the pump

- Check the operating fluid level in the sightglass.
- Compare the voltage and frequency information on the rating plate with the mains voltage and frequency values.
- Check that the exhaust connection allows free flow (max. permissible pressure 1.5 bar absolute).
 - Activate the shut-off valves in such a way that they open before or at the same time as the pump is started.
- Protect the pump sufficiently from taking in contaminants by means of suitable precautions (e.g. dust filters); if necessary, check operating fluid regularly or replace at shorter intervals.

6.2 Switching on the pump

The pump can be switched on in any pressure range.

No special precautions are necessary when pumping dry gases. In order to attain the lowest possible final pressures, the gas ballast valve should be closed.



CAUTION

Hot surface!

Danger of burns if hot parts are touched. Depending on the operating and ambient conditions, the surface temperature of the pump may rise above 70 °C.

- In this case, use suitable finger guards.

6.3 Pumping condensable vapours

Should the process gases contain condensable gases present at high percentages, the rotary vane pump must be operated with a gas ballast (i.e. with an open gas ballast valve).



CAUTION

Bad final vacuum and damage to the pump!

Danger of condensation and corrosion due to exceeding the water vapour compatibility (see Technical data) during operation without a gas ballast or in case of insufficient supply of flushing gas.

- Only pump vapours when the pump is warm and the gas ballast valve is open.
- When the process has been completed, allow the pump to continue running for about 30 minutes with the vacuum flange closed and the gas ballast open for operating fluid regeneration purposes.

No special precautions are necessary when pumping dry gases, provided that the correct pump version is used with the operating fluid specified for it.

Gas ballast valve, standard version

To avoid condensation in the pump when pumping condensable vapours, ambient air or alternatively inertgas is periodically fed into the working chamber at the beginning of the compression phase via the gas ballast valve 74.

The gas ballast valve is closed when turning to the right to position 0 and open when turning to the left to position 1. Intermediate settings are not possible.

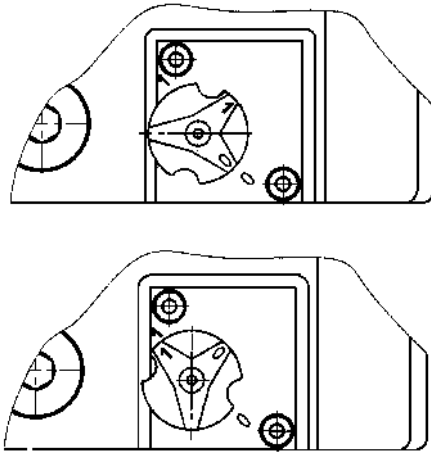

Fig. 11: Standard version 74 of gas ballast valve

Gas ballast valve, corrosive gas version

If the pumping process requires the connection of flushing gas, the C version of the gas ballast with the flushing gas connection must be used.

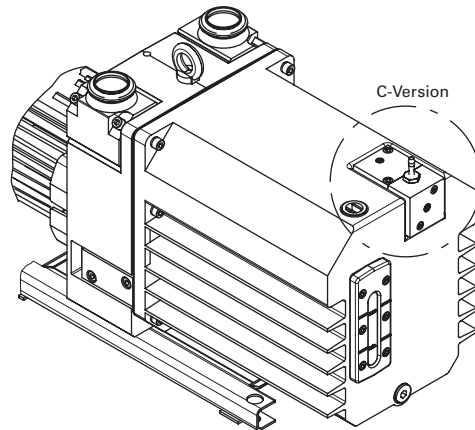

Fig. 12: Gas ballast valve, corrosive gas version

- Connect flushing gas at the hose nozzle of the gas ballast valve.
- Set flushing gas pressure; maximum pressure 1.5 bar (absolute).
 - Select the type and amount of flushing gas depending on the process; consult Pfeiffer Vacuum if necessary.



CAUTION

Flushing gas pressure higher than allowed endangers the operational reliability of the pump.

The power input of the pump, the temperature and the ejection of operating fluid will increase.

- Observe the maximum permissible flushing gas pressure.
- Set the maximum permissible flushing gas pressure via the spindle in the gas ballast valve or on site!

6.4 Switching off the pump

The pump can be switched off in any pressure range.

Rotary vane pumps have an integrated safety valve on the intake side. If the differential pressure between the exhaust side and the intake side is ≥ 250 mbar, then the valve closes automatically and vents the pump when the pump is switched off.

→ Switch the pump off at the mains switch or disconnect from the mains in a secure manner.

Venting the vacuum chamber



CAUTION

Danger of backflow of operating fluid into the intake line!

Contamination of the connected vacuum system!

- Vent the vacuum chamber within 30 s, regardless of the chamber size.
- For a longer venting process, use an additional shut-off valve and shut off the intake line after switching off the pump.

Maintaining the vacuum in the chamber



CAUTION

Danger of backflow of operating fluid into the intake line!

Contamination of the connected vacuum system!

- Because the safety valve of the pump is not suitable for longer-term sealing, install an additional shut-off valve in the intake line.
- Shut off the intake line immediately after switching off the pump.

7 Maintenance

7.1 Precautions



WARNING

Danger of injury from moving parts!

After power failure or motor shutdown due to overheating, the motor may restart automatically.

- Secure the motor so that it cannot be switched on while any work is being performed on the pump.
- If necessary, dismantle the pump from the installation for inspection.



WARNING

Pump parts may be contaminated from pumped media!

Danger of poisoning due to contact with harmful substances.

- Decontaminate the pump before carrying out any maintenance work.
 - In the event of contamination, take suitable safety precautions to prevent your health from being harmed by any dangerous substances.
-
- Allow the pump to cool to a safe temperature.
 - Only dismantle the pump as far as necessary in order to repair defects.
 - Dispose of used operating fluid in compliance with local regulations.
 - When using synthetic operating fluids or working with toxic substances or substances contaminated with corrosive gases, the relevant instructions governing their use must be observed.
 - Use only alcohol or similar agents for cleaning pump parts.

Checklist for inspection, maintenance and overhaul

Certain repair and overhaul work should only be performed by Pfeiffer Vacuum Service (PV). Pfeiffer Vacuum will be released from all warranty and liability claims if the required intervals for inspection, maintenance, or overhaul are exceeded or inspection, maintenance, repair or overhaul procedures are not performed properly. This also applies if replacement parts other than Pfeiffer Vacuum OEM replacement parts are used.

Activity	daily	as required; at least annually	as required; at least every 2 years	as required; at least every 4 years
Check operating fluid level	X			
Visual inspection (leak-tightness/oil leaks)	X			
Check filter insert of external oil mist filter (if existent)	X			
Change filter insert of external oil mist filter (if existent)		X		
Change operating fluid		X		
Change oil filter (if existent)		X		
Cleaning the pump and renew the seals		X		
Clean gas ballast valve and silencer		X		
Clean the motor fan cap		X		
Replace radial shaft seal			X (PV)	
Clean or change vacuum safety valve			X (PV)	
Clean or change exhaust valves			X (PV)	
Change vanes				X (PV)
Check or change coupling				X (PV)

Depending on the process, the required replacement intervals for lubricants and the intervals for inspection, maintenance and overhaul may be shorter than the guide values specified in the table. Consult with Pfeiffer Vacuum Service if necessary.

7.2 Changing the operating fluid

The changing interval for the operating fluid depends on the pump applications.



NOTE
<p>Depending on the applications, Pfeiffer Vacuum recommends determining the exact service life of the operating fluid during the first year of operation.</p> <p>The replacement interval may vary from the guide value specified by Pfeiffer Vacuum depending on the thermal and chemical loads, and the accumulation of suspended particles and condensation in the operating fluid.</p>

- Change the operating fluid at least once every year.
- The level of deterioration of operating fluid P3 can be read off the colour scale in accordance with DIN 51578; request the supplementary sheet PK 0219 BN or download it from the Internet.
- Fill the specimen in a test tube or some similar vessel and test by holding against the light.
- Where discolouration is dark yellow to red brown (equivalent to 4 ... 5 on the scale) change operating fluid.
- Switch off pump.
- Unscrew operating fluid drain screw 142 and drain operating fluid.

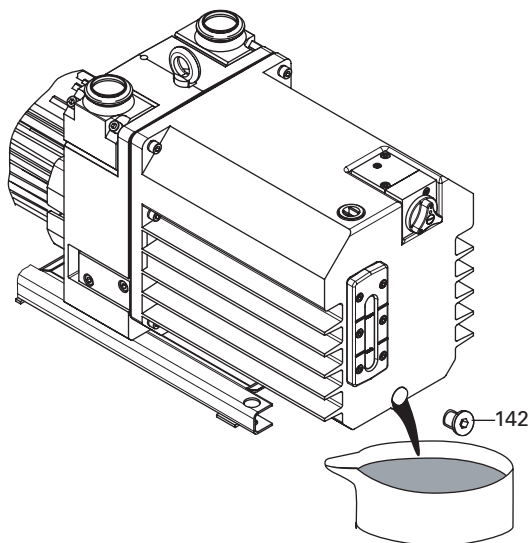

Fig. 13: Draining the operating fluid



WARNING	
Hot operating fluid!	Danger of burns when draining due to contact with skin. → Wear suitable protective clothing.



WARNING	
Operating fluid may contain toxic substances from the pumped media!	Danger of poisoning from the emission of harmful substances (radioactive, toxic, etc.) from the operating fluid. → Wear suitable protective clothing and respirators. → Dispose of operating fluid according to the local regulations

- Screw in operating fluid drain screw 142; pay attention to o-ring.
- Allow pump to run for a maximum of 5 seconds with the vacuum flange open.
- Drain off remaining operating fluid.
 - In case of serious contamination, the operating fluid will have to be changed several times (flushing):

Flushing

- Fill up with operating fluid to the middle of the sight glass.
- Operate the pump with the gas ballast open until the pump has warmed up.
- Drain the operating fluid again and check for contamination, flush again if necessary.
- Screw the operating fluid drain screw back in.
- Fill up with operating fluid and check the filling level (see p. 13, chap. 5.5).



NOTE	
Request safety data sheets for operating fluids and lubricants	from Pfeiffer Vacuum or download them from the Internet. → Dispose of operating fluid according to the local regulations.

7.3 Cleaning the gas ballast valve

Gas ballast valve only becomes dirty if dusty ambient air is sucked in.

- Unscrew screw 74.4 (standard version).
- Remove gas ballast head 74.5. Be careful with O-rings 74.14 and 74.18 (standard version).
- Unscrew two screws 74.22 (74.23 C version).
- Remove gas ballast flange 74.2 (74.7 C version); take care with O-rings 74.18 and 74.20.
- Unscrew screw 74.26, remove washer 74.32 and plate spring 74.6.
- DC-Version: remove circlip 74.34.
- Unscrew spindle 74.8 with O-rings 74.10 and 74.12.
- Unscrew hose nozzle 74.9 with O-ring 74.16.
- Clean nozzle opening in gas ballast flange 74.2 (74.7 C version).
- Check plate spring 74.6 and replace if necessary.
- Unscrew silencer screw 74.3; be careful with O-ring 74.12.
- Unscrew 2 screws 184 from gas ballast valve housing 74.1, take care with O-rings 232 and 238.
- Clean all parts and, if necessary, replace defective parts or gas ballast valve complete.
- Assembly in reverse order.

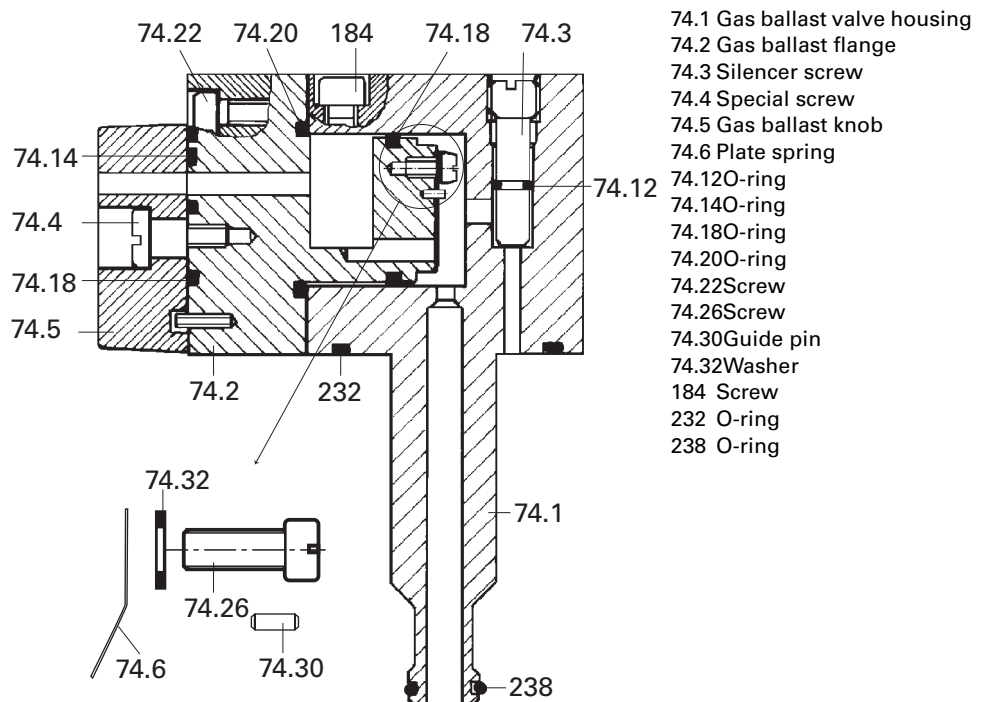
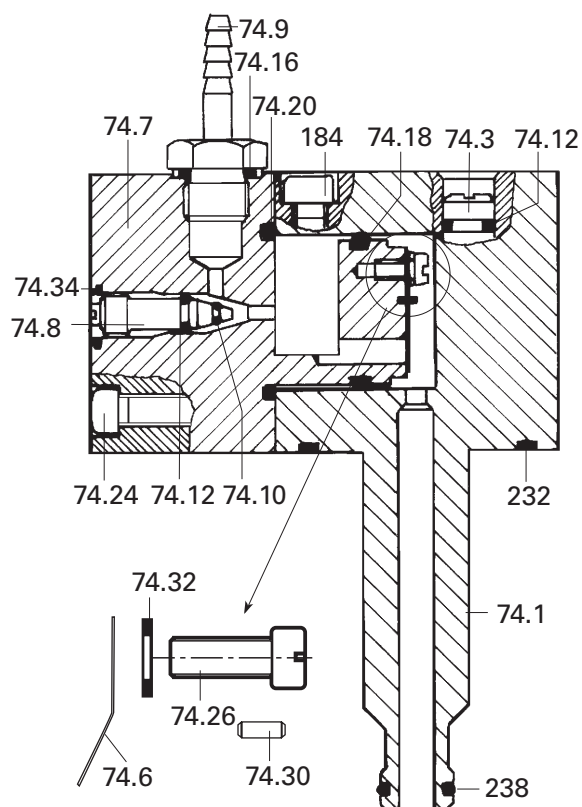

Fig. 14: Gas ballast valve standard version 74, PK 223 664-U



- 74.1 Gas ballast valve housing
- 74.3 Silencer screw
- 74.7 Special gas ballast flange
- 74.8 Spindle
- 74.9 Hose connecting piece
- 74.10O-ring
- 74.12O-ring
- 74.16O-ring
- 74.18O-ring
- 74.20O-ring
- 74.24Screw
- 74.34Circlip
- 184 Screw
- 232 O-ring
- 238 O-ring

Fig. 15: Gas ballast valve C version 74, (set of retrovit: PK 223 713-U)

7.4 Cleaning and setting the silencer

The silencer is a nozzle set inside the gas ballast flange which silences the knocking sound of the oil. When dirty it should be cleaned or replaced.

Cleaning the silencer

- Unscrew silencer screw 74.3; be careful with O-ring 74.12.
- Clean the boring.
- Re-fit silencer 74.3 with O-ring 74.12.

Adjusting the silencer

- First screw silencer screw 74.3 tight.
- Turn gas ballast knob 74.5 clockwise, in position "0".
 - C version: Close spindle 9 by turning to the right.
- A knocking sound soon will be audible when the pump is running.
- Slowly loosen silencer screw 74.3 until the knocking sound disappears.

Adjusting the gas ballast level

C version The gas ballast level can be adjusted by turning the spindle 74.8:

- Turning to the left: Open.
- Turning to the right: Closed.

7.5 Checking the oil level in the oiler (only for C version pumps)

Pumps in the corrosive gas version come equipped with an additional oiler. In these versions the cavity between the radial shaft seal rings on the rotor shaft are supplied with operating fluid by an oiler.

- Check oil level during continuous operation on a daily basis, otherwise each time the pump is switched on.
- When filling, oiler 110 should only be filled up to the "max." mark on sightglass 114;
 - use the same operating fluid as in the pump.

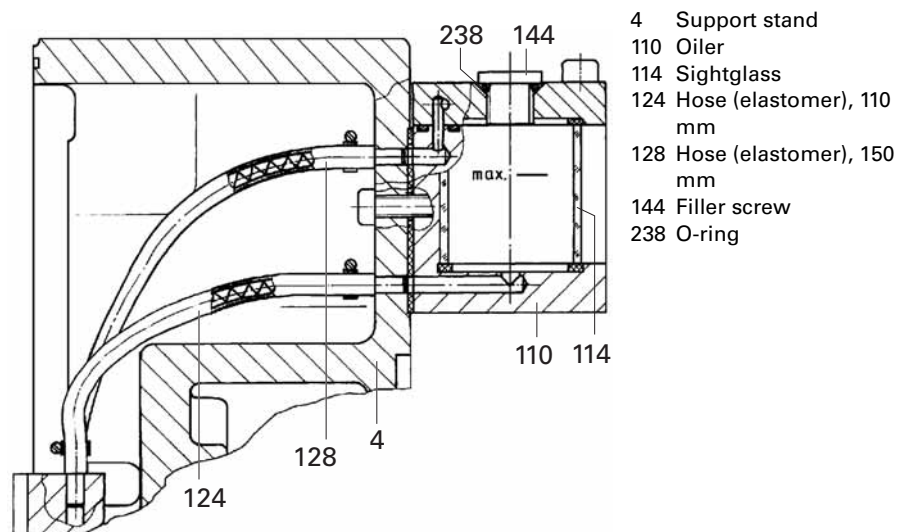

8 Decommissioning

8.1 Shutting down for longer periods

Before shutting down the pump, observe the following procedure and adequately protect the pump system against corrosion:

- Switch off pump.
- Change operating fluid (see p. 19, chap. 7.2).
- Start the pump and allow the pump to warm up.
- Fill up the pump with new operating fluid to the top edge of the sightglass.
- Close vacuum flange and exhaust flange with locking caps.

8.2 Restarting the pump

Visually inspect the inner of the pump before taking it into operation. If there is evidence of rust on the parts of the pump which form the housing then do not take it into operation and contact Pfeiffer Vacuum Service.

Depending on how long the pump is taken out of operation, it may be necessary to replace the radial shaft sealing rings. With reference to DIN 7716 and the manufacturer's specifications we recommend replacing the installed elastomer parts after 2 years.

- If drying pearls were inserted then they should be removed now. Improper handling can cause failure of the pump.



CAUTION

Emission of operating fluid!

Danger of the operating fluid being emitted at the exhaust flange if overfilled.

- Drain the operating fluid to the normal level before restarting the pump.

8.3 Disposal

Products or parts thereof (mechanical and electrical components, operating fluids, etc.) may cause environmental burden.

- Safely dispose of the materials according to the locally applicable regulations.

9 Malfunctions

Please note the following instructions should the pump malfunction:



DANGER

Strong magnetic field in the vicinity of the drive system!

Danger to life for persons with cardiac pacemakers when the drive system is disassembled.

- Persons with cardiac pacemakers must not enter the area of the magnetic field.
- Disassembled magnetic couplings must be kept away from computers, data storage media and other electronic components.



CAUTION

Hot surface!

Danger of burns if hot parts are touched. The surface temperature of the pump may rise above 105 °C in case of malfunction.

- Carry out work on the pump only after it has cooled to a safe temperature.



NOTE

Motor overload!

Depending on the malfunction (e.g. blocking during cold start), the motor may not be sufficiently protected by the built-in thermal protection switch from damage through overheating.

- Implement an additional network safety device.

9.1 Troubleshooting

Problem	Possible causes	Remedy
Pump will not start up	No mains voltage or voltage does not correspond to the motor data	Check mains voltage and mains fuse protection; check motor switch
	Pump temperature too low	Warm up pump to > 12°C
	Thermal protection switch has responded	Detect and fix cause of overheating; allow pump to cool off if necessary.
	Pump system dirty	Clean pump; contact Pfeiffer Vacuum Service if necessary.
	Pump system damaged	Clean and overhaul pump; contact Pfeiffer Vacuum Service if necessary.
Pump switches off after a while after being started	Motor defective	Replace motor
	Thermal protection switch of the motor has responded	Detect and fix cause of overheating; allow motor to cool off if necessary.
	Mains fuse protection triggered due to overload (e.g. cold start)	Warm up pump
Pump does not attain final pressure	Exhaust pressure too high	Check opening of exhaust line and exhaust accessories
	Measurement reading is false	Check gauge, check final pressure without installation connected.
	Pump or connected accessories are dirty	Clean pump and check components for contamination.
	Operating fluid dirty	Operate pump for a longer period with gas ballast valve open or change operating fluid
	Leak in system	Repair leak
	Operating fluid filling level too low	Top off operating fluid
Pumping speed of pump too low	Pump damaged	Contact Pfeiffer Vacuum Service.
	Intake line not well-dimensioned	Keep connections as short as possible and see that cross-sections are sufficiently dimensioned
Loss of operating fluid	Exhaust pressure too high	Check opening of exhaust line and exhaust accessories
	Swivel gasket leaky	Check tightness; replace gasket if necessary
	Radial shaft seal ring leaky	Replace seal ring and check bushing
Unusual operating noises	Operational loss of operating fluid	If necessary, install oil mist filter and oil return unit
	Silencer dirty	Clean or replace the silencer.
	Damage to the pump system	Clean and overhaul pump; contact Pfeiffer Vacuum Service if necessary.
	Motor bearing defective	Replace motor; contact Pfeiffer Vacuum Service if necessary



NOTE

Service work should only be carried out by qualified personal!

Pfeiffer Vacuum is not liable for any damage to the pump resulting from work carried out improperly.

→ Take advantage of our service training programs from technical training; additional information at www.pfeiffer-vacuum.net.

→ Please state all the information on the pump rating plate when ordering spare parts.

10 Service

Pfeiffer Vacuum offers first-class service!

- Maintenance/repairs on the spot by Pfeiffer Vacuum field service
- Maintenance/repairs in the nearby service center or service point
- Fast replacement with exchange products in mint condition
- Advice on the most cost-efficient and quickest solution

Detailed information and addresses at: **www.pfeiffer-vacuum.net (Service)**.

Maintenance and repairs in the Pfeiffer Vacuum ServiceCenter

The following steps are necessary to ensure a fast, smooth servicing process:

- Download the RMA¹⁾ form and contamination declaration.
- Fill in the RMA form and send it by fax or e-mail to your service address.
- Enclose the RMA confirmation of receipt from Pfeiffer Vacuum in the shipment.
- Fill in the contamination declaration and enclose it in the shipment (required!).
- Dismantle all accessories.
- Drain operating fluid/lubricant.
- Drain cooling medium, if used.
- Send the pump or unit in its original packaging if at all possible.

Returning contaminated vacuum pumps

Units which are microbiologically, explosively or radioactively contaminated will not be accepted by Pfeiffer Vacuum as a matter of principle. Hazardous substances are substances and compounds in accordance with the hazardous goods directive (current version). Should pumps be contaminated or the contamination declaration be missing, Pfeiffer Vacuum will decontaminate the pumps at your cost.

Returning contaminated pumps or units

- Neutralise the pump/unit by flushing it with nitrogen or dry air.
- Close off all openings so that they are air-tight.
- Seal the pump/unit in suitable protective film.
- Only return the pump/unit in a suitable and sturdy transport container.

All service orders are carried out exclusively according to our repair conditions for vacuum units and components.

¹⁾ RMA: Return Material Authorization

11 Spare parts

Please also specify model number of the the rating plate when ordering accessories or spare parts.

Set of seals

The set of seals contains all seals including all o-rings of the assembly groups and the subassemblies.

Maintenance kit

The pack contains the o-rings of the operating fluid filler and drain screw for changing the operating fluid. Also the radial shaft seal ring(s), the o-ring for the casing after cleaning the operating fluid sump and the coupling star are included.

Overhaul kit

The pack contains all wearing parts of the pump to replace the following parts after dismantling the whole pump:

- Set of seals
- Wearing parts of the pumping system
- Wearing parts of the vacuum safety valve
- Wearing parts of the gas ballast valve.

Pumping system

The pack contains an assembled pumping system, tested with operating fluid P3 or F5 (only for C-Version).

Set of vanes

The pack contains the vanes of the pump stages and the vane springs.

Set of vacuum safety valve

The pack contains the wearing parts of the vacuum safety valve. Also the o-rings between the valve housing and the pumping system and the o-ring of the casing are included.

Set of discharge valves

The pack contains the wearing parts of the discharge valves. Also the wearing parts of the exhaust valve and the o-ring of the casing are included.

Coupling kit

The pack contains the coupling halves, coupling set and the fan.

Coupling kit (valid for M/MC version))

The pack contains the coupling halves the can and the respective o-ring.

11.1 Spare parts packages

The spare parts packages listed here are only applicable for standard models. Please state all information on the rating plate when ordering spare parts. Other spare parts than those described in this manual must not be used without the agreement of Pfeiffer vacuum.

Pump type with revision index "A"	Set of seals	Maintenance kit	Overhaul kit	Pumping system	Set of vanes	Vacuum safety valve	Discharge valves	Coupling kit
UNO 35	PK E20 001 -T	PK E21 001 -T	PK E22 001 -T	PK E23 001 -T	PK E28 001 -T	PK E24 001 -T	PK E25 001 -T	PK E26 001 -T
UNO 65	PK E20 001 -T	PK E21 001 -T	PK E22 003 -T	PK E23 002 -T	PK E28 002 -T	PK E24 001 -T	PK E25 002 -T	PK E26 001 -T
DUO 35	PK E20 001 -T	PK E21 002 -T	PK E22 005 -T	PK E23 003 -T	PK E28 003 -T	PK E24 001 -T	PK E25 001 -T	PK E26 001 -T
DUO 65	PK E20 001 -T	PK E21 001 -T	PK E22 011 -T	PK E23 006 -T	PK E28 005 -T	PK E24 001 -T	PK E25 004 -T	PK E26 001 -T
C version								
DUO 35 C	PK E20 003 -T	PK E21 003 -T	PK E22 007 -T	PK E23 004 -T	PK E28 004 -T	PK E24 001 -T	PK E25 003 -T	PK E26 001 -T
DUO 65 C	PK E20 003 -T	PK E21 003 -T	PK E22 014 -T	PK E23 007 -T	PK E28 006 -T	PK E24 001 -T	PK E25 005 -T	PK E26 001 -T
M version								
DUO 35 M	PK E20 001 -T	PK E21 002 -T	PK E22 010 -T	PK E23 005 -T	PK E28 003 -T	PK E24 001 -T	PK E25 001 -T	PK E26 002 -T
DUO 65 M	PK E20 001 -T	PK E21 002 -T	PK E22 012 -T	PK E23 012 -T	PK E28 005 -T	PK E24 001 -T	PK E25 004 -T	PK E26 002 -T
MC version								
DUO 35 MC	PK E20 001 -T	PK E21 002 -T	PK E22 017 -T	PK E23 009 -T	PK E28 004 -T	PK E24 001 -T	PK E25 003 -T	PK E 26 004 -T
DUO 65 MC with P3	PK E20 001 -T	PK E21 002 -T	PK E22 015 -T	PK E23 012 -T	PK E28 006 -T	PK E24 001 -T	PK E25 004 -T	PK E 26 004 -T
DUO 65 MC with F5	PK E20 001 -T	PK E21 002 -T	PK E22 016 -T	PK E23 010 -T	PK E28 006 -T	PK E24 001 -T	PK E25 004 -T	PK E 26 004 -T

12 Accessories

Further detailed accessories are contained in the Pfeiffer Vacuum printed Catalogue or the Online Catalogue.

Description	Size	Number	Comments/ (relevant manual)
Gas ballast valve, retrofit kit		PK 223 713 -U	C version (for flushing gas connection)
Gas ballast valve with solenoid valve, retrofit kit		PK 223 717 -U	C version (24 V/DC)
Dust separator STZ 040	DN40 ISO-KF	PK Z60 008	PK 0120 BN
Dust separator STR 040	DN40 ISO-KF	PK Z60 108	PK 0120 BN
Oil mist filter ONF 35/65	DN40 ISO-KF	PK Z40 150	PK 0183 BN
Oil mist filter ONFR 35/65	DN40 ISO-KF	PK Z40 151	PK 0183 BN
Oil mist filter ONF 35/65 C	DN40 ISO-KF	PK Z40 152	PK 0183 BN, C-Version
Oil mist filter ONFR 35/65 C	DN40 ISO-KF	PK Z40 153	PK 0183 BN, C version
Oil return retrofit kit		PK 005 710 -T	
Chemical oil filter OFC 35/65		PK Z90 320	PK 0182 BN
Mechanical oil filter OFM 35/65		PK Z90 321	PK 0184 BN
Condensate separator KAS 040	DN40 ISO-KF	PK Z10 008 A	PK 0116 BN
Cooling trap KLF 040	DN40 ISO-KF	auf Anfrage	PD 0015 BN
Adsorption filter FAK 040	DN40 ISO-KF	auf Anfrage	PD 0017 BN
Adsorption filter FBL 040	DN40 ISO-KF	auf Anfrage	PD 0017 BN
Zeolite trap ZFO 040 ¹	DN40 ISO-KF	auf Anfrage	PD 0016 BN
Operation control unit with oil pressure switch		PK 223 720 -U	PK 0191 BN
Operation control unit with oil pressure switch when using OFC/OFM		PK 223 741 -U	PK 0191 BN
Sight glass adapter without sensors		PK 223 721 -U	PK 0190 BN
Sight glass adapter complete with sensors		PK 223 739 -U	PK 0190 BN
Sight glass adapter with operating fluid level control		PK 223 718 -U	PK 0190 BN
Operating fluid P3	1 litre	PK 001 106 -T	
Operating fluid P3	5 litre	PK 001 107 -T	
Operating fluid P3	20 litre	PK 001 108 -T	
Operating fluid D1	1 litre	PK 005 875 -T	
Operating fluid D1	5 litre	PK 005 876 -T	
Operating fluid D1	20 litre	PK 005 877 -T	
Operating fluid F5	1 litre	PK 001 852 -T	C version
Operating fluid F5	5 litre	PK 001 853 -T	C version
Operating fluid F5	0,25 litre	PK 001 854 -T	C version
PTC resistor tripping unit		P 4768 051 FQ	

¹ filled with zeolite

13 Technical Data

UNO/DUO 35

Feature	UNO 35	DUO 35
Flange (in)	DN 40 ISO-KF	DN 40 ISO-KF
Flange (out)	DN 40 ISO-KF	DN 40 ISO-KF
Pumping speed at 50 Hz	32 m ³ /h	32 m ³ /h
Pumping speed at 60 Hz	36 m ³ /h	36 m ³ /h
Ultimate pressure with gas ballast	≤ 5·10 ⁻² mbar	≤ 5·10 ⁻³ mbar
Ultimate pressure without gas ballast	≤ 1 mbar	≤ 3·10 ⁻³ mbar
Leakage rate safety valve	≤ 1 · 10 ⁻⁴ mbar · l/s	≤ 1 · 10 ⁻⁴ mbar · l/s
Water vapor tolerance at 50 Hz	30 mbar	20 mbar
Water vapor tolerance at 60 Hz	30 mbar	20 mbar
Water vapor capacity 50 Hz	700 g/h	500 g/h
Water vapor capacity 60 Hz	780 g/h	560 g/h
Emission sound pressure level without gas ballast	≤ 61 dB (A)	≤ 61 dB (A)
Pump fluid filling	4,5 l	3.2 l
Rated power 50 Hz	1.1 kW	1.1 kW
Rated power 60 Hz	1.25 kW	1.25 kW
Nominal rotation speed at 50 Hz	1400 rpm	1400 rpm
Nominal rotation speed at 60 Hz	1690 rpm	1690 rpm
Weight	50 kg	56 kg

UNO/DUO 65

Feature	UNO 65	DUO 65
Flange (in)	DN 40 ISO-KF	DN 40 ISO-KF
Flange (out)	DN 40 ISO-KF	DN 40 ISO-KF
Pumping speed at 50 Hz	62 m ³ /h	62 m ³ /h
Pumping speed at 60 Hz	70 m ³ /h	70 m ³ /h
Ultimate pressure with gas ballast	≤ 5·10 ⁻² mbar	≤ 5·10 ⁻³ mbar
Ultimate pressure without gas ballast	≤ 1 mbar	≤ 3·10 ⁻³ mbar
Leakage rate safety valve	≤ 1 · 10 ⁻⁴ mbar · l/s	≤ 1 · 10 ⁻⁴ mbar · l/s
Water vapor tolerance at 50 Hz	30 mbar	20 mbar
Water vapor tolerance at 60 Hz	30 mbar	20 mbar
Water vapor capacity 50 Hz	1400 g/h	1000 g/h
Water vapor capacity 60 Hz	1580 g/h	1120 g/h
Emission sound pressure level without gas ballast	≤ 61 dB (A)	≤ 61 dB (A)
Pump fluid filling	5,4 l	4.2 l
Rated power 50 Hz	1.5 kW	1.5 kW
Rated power 60 Hz	1.7 kW	1.7 kW
Nominal rotation speed at 50 Hz	1400 rpm	1400 rpm
Nominal rotation speed at 60 Hz	1690 rpm	1690 rpm
Weight	60 kg	65 kg

13.1 Dimension diagram

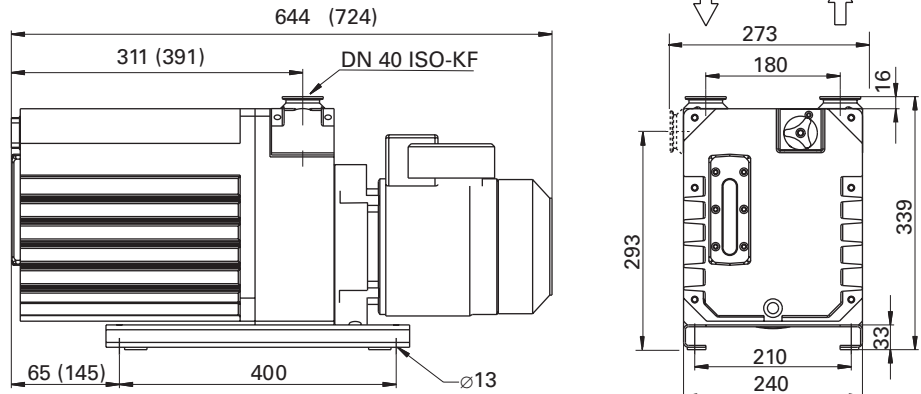

(...) --> UNO/DUO 65

Fig. 16: UNO/DUO 35/65

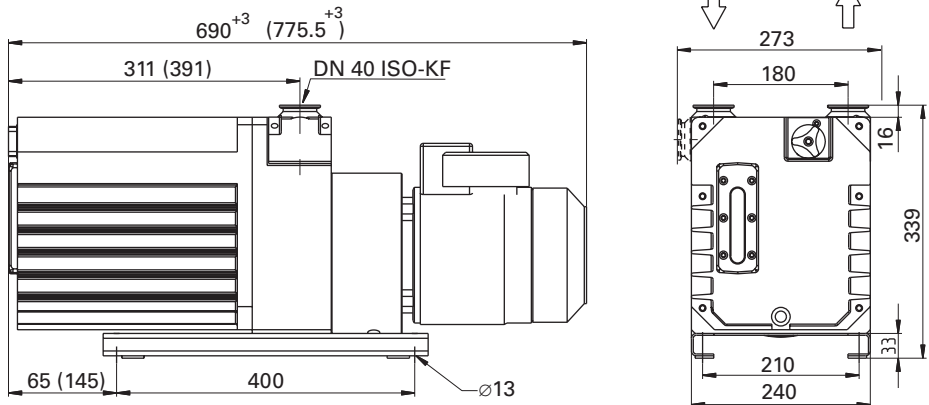

(...) --> DUO 65 M

Fig. 17: DUO 35/65 M

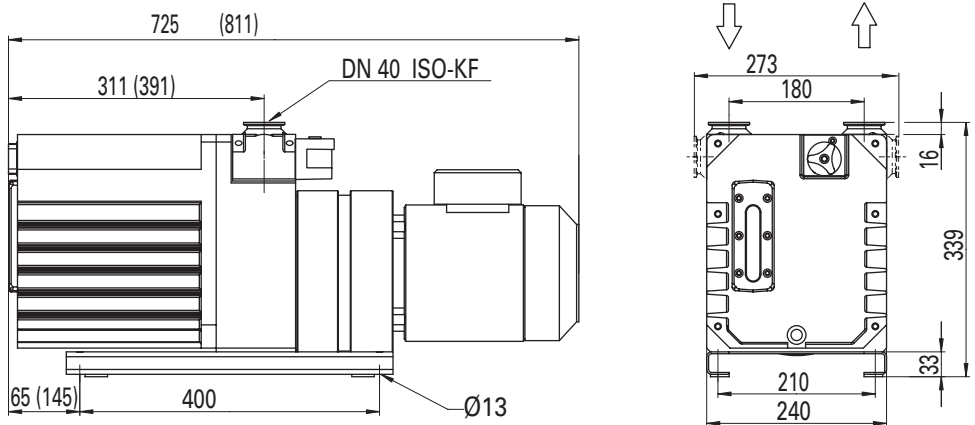

(...) --> DUO 65 MC

Fig. 18: DUO 35/65 MC



Declaration of conformity

according to the EC directive:

- **Machinery 2006/42/EC (Annex II, no. 1 A)**

We hereby declare that the product cited below satisfies all relevant provisions of EC directive "Machinery" **2006/42/EC**.

In addition, the product cited below satisfies all relevant provisions of EC directive "Electromagnetic Compatibility" **2004/108/EC**.

The agent responsible for compiling the technical documentation is Mr. Sebastian Oberbeck, Pfeiffer Vacuum GmbH, Berliner Straße 43, 35614 Asslar.

DuoLine[®]/DuoLine[™]

UNO/DUO 35/65

DUO 35/65 C/MC

UNO/DUO 35/65 M

Guidelines, harmonised standards and national standards and specifications which have been applied:

DIN EN ISO 12100-1 : 2004	DIN EN 61010 : 2002	DIN EN 61000-6-3 : 2007
DIN EN ISO 12100-2 : 2004	DIN EN ISO 13857 : 2008	DIN EN 61000-6-4 : 2007
DIN EN 1012-2 : 1996	DIN EN 61000-6-1 : 2007	
DIN EN ISO 14121-1 : 2007	DIN EN 61000-6-2 : 2006	

Signatures:

Pfeiffer Vacuum GmbH
Berliner Straße 43
35614 Asslar
Germany

(M. Bender)
Managing Director

(Dr. M. Wiemer)
Managing Director

CE/2010

Vacuum is nothing, but everything to us!



Turbopumps



Rotary vane pumps



Roots pumps



Dry compressing pumps



Leak detectors



Valves



Components and feedthroughs



Vacuum measurement



Gas analysis



System engineering



Service

PFEIFFER  **VACUUM**

Pfeiffer Vacuum Technology AG · Headquarters/Germany

Tel. +49-(0) 64 41-8 02-0 · Fax +49-(0) 64 41-8 02-2 02 · info@pfeiffer-vacuum.de · www.pfeiffer-vacuum.net