

Operating Instructions

DCU 001

DCU 100

DCU 150

DCU 200

DCU 300

DCU 600

Anzeige- und Bediengerät Display And Operating Unit

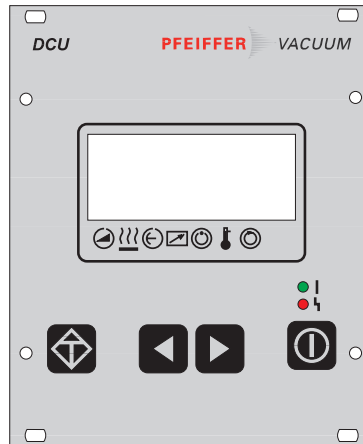

Index

	Page
1. Safety Instructions	3
2. Understanding The Control And Operating Unit DCU	4
2.1. For Your Orientation	4
2.2. Product Description	4
Mechanical Design	4
Connection Options	5
Proper Use	5
Improper Use	5
2.3. Front Panel	5
2.4. Rear Panel	6
3. Installation	7
3.1. Preparations For Installation	7
3.2. Rack Fitting	7
3.3. Connecting Diagram	7
3.4. Making The Connections	8
4. Operations	8
4.1. Short Overview, Operating	8
4.2. General	9
4.3. Switching On The DCU	9
Self-Testing	9
4.4. Functions Of The Keys	10
4.5. LC-Display	11
4.6. Symbol Definitions	12
4.7. LED Display	13
4.8. The Serial Interface	13
5. Error Codes	13
5.1. General	13
5.2. Errors During Self-Testing	13
6. What To Do In Case Of Breakdowns ?	14
7. Maintenance, Service	14
8. Technical Data	15
8.1. Data List	15
8.2. Dimensions	15
9. Supplementary Informations	16
Manufacturer's Declaration	Appendix 1

1. Safety Instructions

- ☞ Read and follow all instructions in this manual.
- ☞ Inform yourself regarding
 - Dangers which can arise from the unit;
 - Dangers which can arise from the system;
- ☞ Follow the safety and accident prevention instructions.
- ☞ Check regularly that all safety and protection requirements are being observed.
- ☞ When installing the DCU, take account of the ambient conditions.
The protection type is IP 20. The units DCU are protected against the ingress of foreign bodies $\geq \varnothing 12$ mm. Since water protection is not provided, the unit should be mounted in a suitable housing (see Section 3. "Installation").
- ☞ Do not carry out any unauthorised modifications or alterations to the DCU.
- ☞ Do not open the housing cover when the unit is connected to the mains nor during pumping operations.
- ☞ Take account of the prescribed mains voltage values when connecting units DCU 100 to DCU 600.
- ☞ When shipping, please note the instructions in Section 7.

Pictogram definitions:



There is danger of an electric shock if the contacts are touched.



There is danger of personal injury.



There is danger of damage to the unit or to the system.

2. Understanding The Display and Operating Unit DCU

2.1. For Your Orientation

Symbols used

The following symbols will be used in the illustrations throughout the manual:

 Electrical connection

Abbreviations used

TMP = Turbomolecular Pump
DCU = Display and Operating Unit
TC = Electronic Drive Unit
TPS = Mains Power Unit

Position numbers

The same accessory parts have the same position numbers in all illustrations.

Operation instruction in the text

➔ Here, you must do something.

2.2. Product Description

The Display Control Unit DCU is an operating unit for PFEIFFER drive units. It enables control over all the main parameters of the unit. Additionally, the connection of a vacuum gauge is possible.

DCU 001 = Basic unit without mains power unit
DCU 100/150/200/300/600 = Unit with mains power unit.

Mechanical Design

The DCU is fitted in a housing suitable for mounting in a 19"/3HE rack.

Connection Options

The DCU provides the following connection options:

- Electronic drive unit for turbopump (X2)
- Pressure gauge (X3).
- Serial interface RS 485.

The units DCU 001, DCU 100 - DCU 600 have been tested and passed by the authorities in accordance with EN 61010/VDE 0411 "Safety Equipment For Electrical Units".

Proper Use

- The display and operating unit DCU may only be used to control PFEIFFER Electronic Drive Units and their peripheral units.
- Instructions concerning installation, start-up, operating and maintenance must be observed.

Improper Use

Improper is:

- Uses not covered above, especially:
 - Connection to pumps and units which is not permitted in their operating instructions.
 - Connection to units which contain touchable and voltage carrying parts.

Improper use will cause any rights regarding liability and guarantees to be forfeited.

2.3 Front panel

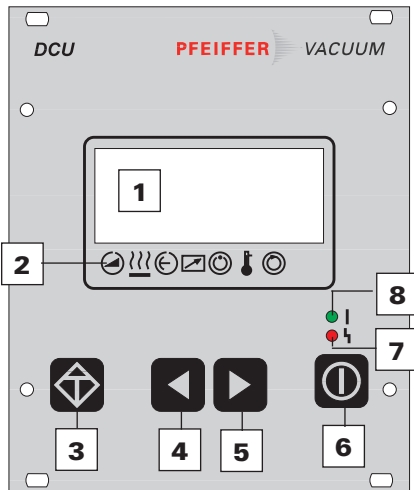

The front panel contains all the operating and display elements.

- 1 LCD display
- 2 Status display (symbol definitions see chapter 4.6.)
- 3 "Error acknowledgement" key
- 4 Key "Left"
- 5 Key "Right"
- 6 "Pumping Station ON/OFF" key
- 7 Red illuminating diode for error status
- 8 Green illuminating diode for operating status

2.4 Rear Panel

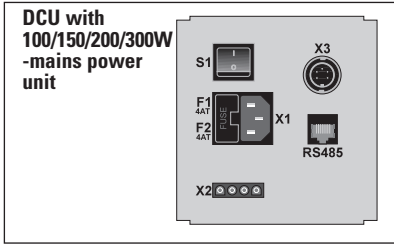

- S1 Mains switch
- F1 Mains fuse
- F2 Mains fuse
- X1 Mains connection 90-265 V~
- X2 Output for voltage supply, electronic drive unit
- X3 Pressure gauge connection
- RS 485 Communication with electronic drive unit

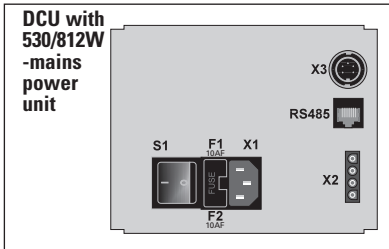

- S1 Mains switch
- F1 Mains fuse
- F2 Mains fuse
- X1 Mains connection 90-265 V~
- X2 Output for voltage supply, electronic drive unit
- X3 Pressure gauge connection
- RS 485 Communication with electronic drive unit

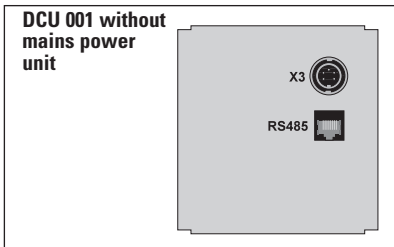

- X3 Pressure gauge connection
- RS 485 Communication with electronic drive unit

3. Installation

3.1. Preparations For Installation



Unauthorised modifications or alterations to the Display Control Unit are not allowed.

The unit must be fitted in a housing taking account of the ambient conditions (see section "Technical Data").

➔ Disconnect mains power plug before installation work.

Installation location: Protected against the weather.

The following is applicable for open buildings and operations rooms which are not fully air conditioned:

Temperature: +5°C - +40°C.
Relative humidity: 5 - 85%, non-condensing.
Air pressure: 86 kPa - 106 kPa

3.2. Rack Fitting

The units DCU 001, DCU 100 - DCU 600 are designed to be fitted into a 19"/3HE rack with guide rails.

- ➔ For installation secure the front panel to the rack using four fixing screws.
- ➔ Ensure free convection. The minimum distance to the upper and lower ventilation slits must be ≥ 50 mm.

The ambient temperature in the rack housing must not exceed 40°C.

Depending on the version, various connections are provided on the DCU.

3.3. Connecting Diagram

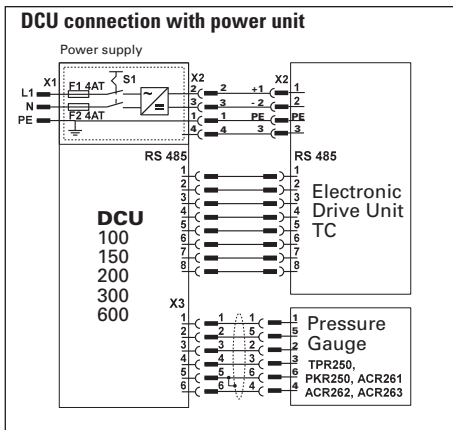
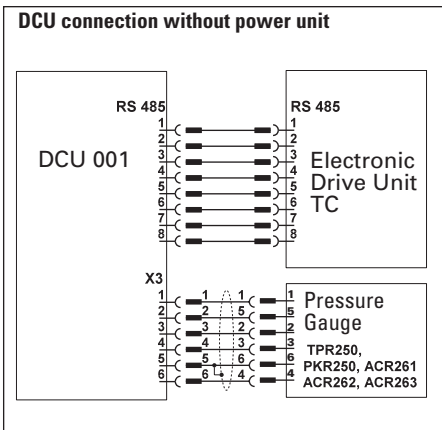

3.4. Making The Connections

- The units DCU 100 - DCU 600 have been designated protection class 1 and must always be connected with the earthed conductor (PE) via the mains cable.

Please note: If using the TC 600 electronic drive unit, please disconnect the remote plug from the RS 485 interface connection.

- ➔ Mains connection must be made in accordance with the local regulations.
- ➔ Make the connection X2 - Electronic Drive Unit in accordance with the connecting diagram, section 3.3.
- ➔ Make the connection pressure gauge to X3 as required.
- ➔ Make the connection RS 485/DCU-RS 485/Electronic Drive Unit via the delivered 8 pole cable.

The DCU 001 is re-supplied with its operating voltage via the Serial Interface RS 485 cable from the Electronic Drive Unit. As soon as this unit is switched on, the DCU is supplied with voltage.

Mains voltage

DCU 100: 90 - 265V~, 125VA

DCU 150: 90 - 265V~, 170VA

DCU 200: 90 - 265V~, 230VA

DCU 300: 90 - 265V~, 330VA

DCU 600: 90 - 132/185-265V~, 590/900VA

4. Operations

4.1. Short Overview, Operating

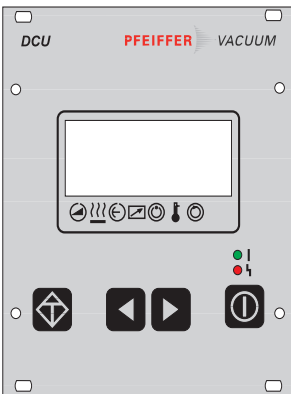

Selecting the parameters

- ➔ Select the parameter numbers with the keys ◀ (back) or ▶ (forward) (keeping the key depressed enables rapid scrolling).

Setting parameters

- ➔ Select a parameter.
 - ➔ Depress keys ◀ and ▶ simultaneously.
 - The arrow (--->) appears in the second line from the top.
 - ➔ Reduce or increase the values with the key ◀ or ▶ respectively.
 - ➔ Depress key ◀ and ▶ simultaneously.
 - The arrow (--->) disappears.
 - The parameter is set.

4.2. General

All function relevant aspects of the pump electronics are illustrated in the form of parameters. Each parameter has a number and a designation (for example, "720: Vent frequ").

The value of the parameter is always readable, in some cases also modifiable via the keyboard.

4.3. Switching On The Control Unit

➔ Make the connection to the Serial Interface RS 485.

DCU 001:

➔ Switch on the external supply of the Electronic Drive Unit (for example TPS 100-600).

DCU 100/150/200/300/600:

➔ Switch on the DCU by the switch S1 on the rear side.

➔ In the event of an error message: depress: .

Self-Testing

After switching on, the DCU performs a self-test and also a test on the connected turbo electronics. Run time of the self-test: approx. 20s. During the test a bar appears in the display in line 4 and this shows the progress of this procedure.

- **Display test:** All signs in the LC display are shown for a short time in black.
- **LED test:** During the whole testing process the red and the green LEDs illuminate.
- **DCU test:** The DCU hardware is tested.
- **Connection to the turbo electronics test:** The correct connection to the turbo electronics and their identity are examined.
- **Parameter test:** Information regarding the parameters is loaded.
- **Identification of the connected components:** The designation of the drive unit is displayed.

Providing there are no errors the DCU is now ready to operate.

4.4. Functions Of The Keys

The four keys on the front panel have the following functions:

Key	Application/Example		Explanation
			Reset (error acknowledgement). Acknowledges errors (red LED illuminates)
		↵309: Act rotspd ↵310: TMP I-Mot	Scroll back parameters Scrolls back a parameter
	—>	↵871 Hz ↵ 872 Hz	Reduce a value (with arrow “—>”)
		↵310: TMP I-Mot ↵311: TMP Op hrs	Scroll parameters forwards Scrolls forward a parameter
	—>	871 Hz ↗ 872 Hz ↗	Increases a value (with arrow “—>”)
		001: Heating ☒ off	Alters a value (⇒ data editing mode) Access to a displayed value, if possible (arrow “—>” appears)
	simultaneously —>	001: Heating off ✓	Confirm a value (⇒ param. selection mode) Takes over an altered value (The arrow “—>” disappears)
	010: Pump stat. on ⇔ off		Pumping Station ON/OFF Switches the pumping station ON and OFF, equivalent to parameter 010: “Pump stat.”

4.5. LC-Display

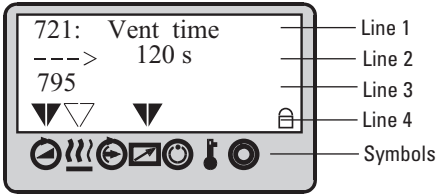

The functions are displayed via a four line LC display. A special function is assigned to each line:

- **Line 1:** Number and name of the selected parameter (for example 721: >>Vent time<<).
- **Line 2:** Relating value. If an arrow (--->) is displayed, the displayed value can be altered.
- **Line 3:** Two functions

Function 1: Messages relating to operations and operating are displayed. (see table “Operating Messages” in the operating instruction “Pumping Operations with DCU” and “Error Codes”, section 5).

Function 2: An optional second parameter in the form of >>Parameter number<< : >>value<< is displayed. The function of this line enables setting via parameter [P:795] >>Servicelin<< at line 1. With >>Servicelin<< all parameters can be displayed. Error messages are displayed independent of the selected function.

- **Line 4:** Arrows which points to the underlying symbol. This restores the unit status.







Please note:

Prolonged depressing of the key  or  enables rapid scrolling and/or alterations to the data.

The data mode (arrow “--->” is displayed) is automatically relinquished, without taking over the values to be altered, under the following conditions:

- No settings or key depressing for longer than 10 seconds.
- The occurrence of an error.
- The key  has been depressed.

4.6. Symbol Definitions

	Symbol	Arrow	Explanation
	Pump	–	No
	accelerates	▼	yes
	Pre-selection	–	No pre-selection
	heating	▽	Pre-selection heating, but switchpoint not attained
		▼	Heating ON, switchpoint attained
	Stand-by	–	Off
		▼	On
	Unit under remote control	–	No
		▼	Yes
	Switchpoint attained	–	No
		▼	Yes
	Excess-temperature	–	No excess temperatures
		▽	Excess temperature pump
		▽	Excess temperature pump elektronik
		▼	Excess temperature pump and pump elektronik
	Final rotation speed attained	–	No
		▼	Yes

4.7. LED Display

The red LED (error status) and green LED (operations status) on the front panel can take on the following conditions:

Red LED

Illuminates: Collective error messages
Flashes: Warning

Green LED

Illuminates: Mains power unit OK, pumping station ON
Flashes: Mains power unit OK, pumping station OFF
Blinks: Mains power failure

4.8. Serial Interface

The serial Interface RS 485 is only used for connecting the pump controller at the vacuum pump. The description of the interface protocol you can find in the operating instruction PM 800 488 BN.

5. Error Codes

5.1. General

Errors ("Errxxx" or "Error Exxx") always causes to shut-down of the TMP, the fan, the heating and the backing pump.

- ➔ After the error is removed depress key .
- The unit is again ready to operate.

Warnings ("Wrnxxx" or "Warning Fxxx") are only displayed and do not cause components to be shut down.

5.2. Errors During Self-Testing

The following errors can occur during self-testing performed when the DCU is switched on:

Display	Error	Possible action
** Error E021 **	• Wrong pump identification resistance	Mains OFF-ON Inform PFEIFFER-Service
** Error E040 **	• Hardware error: external RAM defective	Inform PFEIFFER-Service
** Error E042 **	• Hardware error: EPROM checksum	Inform PFEIFFER-Service
** Error E090 **	• Insufficient RAM • The DCU is connected to the wrong pump electronic	Inform PFEIFFER-Service Connect correct pump electronic
** Error E698 **	• The connected drive unit does not respond	Check communication lead between electronic drive unit and DCU, switch on electronic drive unit

6. What To Do In Case of Breakdowns ?

Check the fuses

In case of an error:

- ➔ Loosen F1/F2 with a screwdriver and check fuses. Replace if defective. Only use fuses with high switching capability.

The safety values are stated on the rear panel of the DCU.

7. Maintenance And Service

The unit requires no maintenance. A damp cloth can be used to wipe away any dirt which has collected on the front panel. Ensure that the unit is first disconnected from the mains power supply.

Do Make Use Of Our Service Facilities

In the event that repairs are necessary a number of options are available to you to ensure any system down time is kept to a minimum:

- Have the unit repaired on the spot by PFEIFFER Service Engineers;
- Return the unit to the manufacturer for repairs;
- Replace with a new value unit.

Local PFEIFFER representatives can provide full details.



When carrying out their own repairs customers must bear in mind that dangerous voltage levels are present.

Please note:

Units returned to us for repair or maintenance are covered by our general conditions of sale and supply.

Contact addresses and telephone hotline:

Please refer to the back cover of this manual for contact addresses and telephone hotline numbers.

8. Technical Data

8.1. Data List

Definition	Unit	DCU 001	DCU 100	DCU 150	DCU 200	DCU 300	DCU 600
Connection voltage:	V DC	12-30 ¹⁾	–	–	–	–	–
	V AC	–	90-132	90-132	90-132	90-132	90-132
	V AC	–	185-265	185-265	185-265	185-265	185-265
Frequency:	Hz	–	50-60	50-60	50-60	50-60	50-60
Max. power consumption.:	VA	≤ 5	≤ 125	≤ 170	≤ 230	≤ 350	590/900 ²⁾
Output voltage X2:	VDC	–	24	24	48	72	140
Max output current X2:	A	–	4,1/4,6 ²⁾	5/6,2 ²⁾	4,1/4,6 ²⁾	3,2/4,2 ²⁾	3,8/5,8 ²⁾
Max output power X2.:	W	–	100/110 ²⁾	120/150 ²⁾	200/220 ²⁾	230/300 ²⁾	530/812 ²⁾
permis. amb. temperature.:	°C	5 - 40					
Max. relative humidity. ³⁾	%	5 - 85					
Air pressure:		86kPa - 106 kPa					
Protection type:		IP 20					
Weight:	kg	0,4	1,6	1,9	1,9	2,2	2,6

1) only supplied by PFEIFFER Electronic Drive Unit
 2) at 90-132 V AC / 185-265 V AC
 3) non condensing

8.2. Dimesions

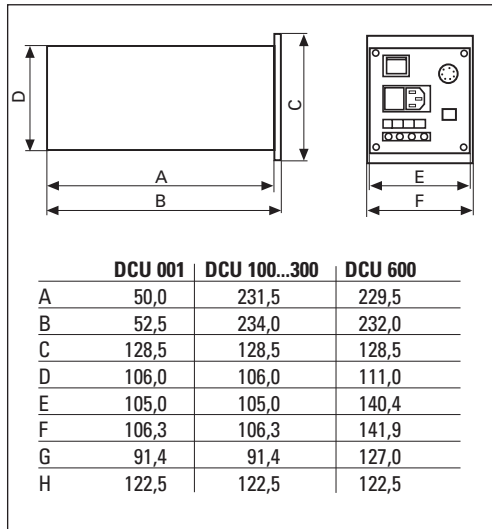
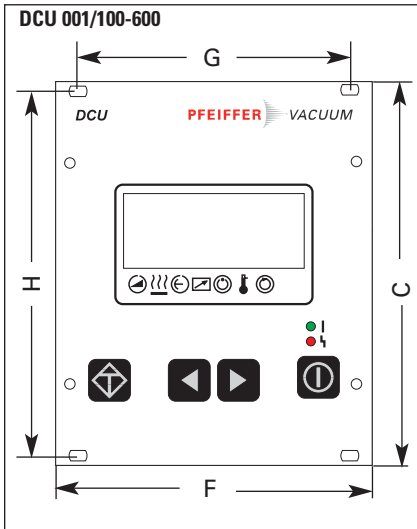

9. Supplementary Information

The Display And Control Unit DCU is a universal component for the control and monitoring of PFEIFFER vacuum pumps and drive units.

Depending on the configuration of your components further operating instructions are included in the delivery consignment (please see the table). If, despite every effort by us, information on your products is missing please get in touch with your local Pfeiffer representatives or call us on the hotline shown on the back cover page. All operating instructions are also available as PDF files.

The following operating instructions are available for the range of pumps which come with DCU control units:

Product	Definition	No. Operating Instruction
Vacuum pump	Description of the Pump	dependent to the pump typ ¹⁾
DCU 001, 100-600	Description of the controller	PM 800 477 BD
Operating turbo pump with DCU	Operating definition/parameter	PM 800 547 BD
TPS 100, 200, 300, 600	Description of the mains power unit	PM 800 521 BD
Housing heating turbo pump	Description of the housing heating	PM 800 542 BD
Air cooling turbo pump	Description of the air cooling	PM 800 543 BD
Water cooling turbopump	Description of the water cooling	PM 800 546 BD
Backing pump relay box ²⁾	Description monitoring of the backing p.	PM 800 544 BD
Temperature Management System TMS	Description heating of the pre vacuum section of the turbo pump	PM 800 570 BD
RS 232/RS 485	Description of the interface	PM 800 488 BD
Level converter RS 232/RS 485	Pump monitoring via RS 232	PM 800 549 BD
TVF 005	Description of the vent valve	PM 800 507 BD

¹⁾ Numbers can be supplied by PFEIFFER Service.

²⁾ Only for rotary vane vacuum pumps.

CE **Konformitätserklärung** **CE**
Declaration of Conformity

im Sinne folgender EU-Richtlinien:
pursuant to the following EU directives:

- **Elektromagnetische Verträglichkeit/***Electromagnetic Compatibility* **89/336/EWG**
- **Niederspannung/***Low Voltage* **73/23/EWG**

Wir bestätigen Konformität mit der EU-Richtlinie über elektromagnetische Verträglichkeit 89/336/EWG und der EU-Niederspannungsrichtlinie 73/23/EWG.

We hereby certify that the product specified below is in accordance with the provision of EU Electromagnetic Compatibility Directive 89/336/EEC and EU Low Voltage Directive 73/23/EEC.

Produkt/*Product*:
DCU 001, DCU 100, DCU 200, DCU 300, DCU 600

Angewendete Richtlinien, harmonisierte Normen und angewendete, nationale Normen:
Guidelines, harmonised standards, national standards in which have been applied:

EN 61010, EN 55011, EN 50081-1, EN 50082-2, IEC 801 1-4, VDE 0843-6

Unterschrift/*Signature*:



Pfeiffer-Vacuum GmbH
Emmeliusstrasse 33
35614 Asslar
Germany

(W. Dondorf)
Geschäftsführer
Managing Director

Konf.II/2000

Zentrale/Headquarters

Pfeiffer Vacuum GmbH

Berliner Strasse 43
D-35614 Asslar

Telefon 06441/802-0

Telefax 06441/802-202

Hotline 06441/802-333

<http://www.pfeiffer-vacuum.de>

Argentina

ARO S.A., Av. Belgrano 369,
1092 Buenos Aires, telephone +54 / 11 4331 5766,
telefax +54 / 11 4331 3572

Australia

Scitech Australia Pty. Ltd., Suite 1B,
10-18 Cliff Street, Milsons Point, NSW 2061,
telephone +61 / 2 9954 1925, telefax +61 / 2 9954 1939

Austria

Pfeiffer Vacuum Austria GmbH
Diefenbachgasse 35, A-1150 Wien,
telephone +43 / 1 8941 704, telefax +43 / 1 8941 707
Service Hotline: +43 / 1 8941704

Branch Office, Czech Republic

Pfeiffer Vacuum Austria GmbH, Branch Prague
Zvonarska 885
CZ-156 00 Praha 5
telephone +420/2 900 42981, telefax +420/2 579 23014

Belgium / Luxemburg

Pfeiffer Vacuum Belgium N.V./S.A.
Luxemburgstraat 5, B-9140 Temse
telephone +32 / 3 710 5920, telefax +32 / 3 710 5929
Service Hotline: +32 / 3 710 5922

Brazil

Emi Tec
Assistencia Técnica e Representação S/C Ltda.
Rua Bernardino de Campos, 551-Brooklin
CEP 04620-002 São Paulo, SP - Brasil
telephone +55 / 11 5532 0740, telefax +55 / 11 5535 3598

Chile

BERMAT S.A., Coyancura 2283, Oficina 601
Providencia, P.O. Box 9781, Santiago
telephone +56 / 2 231 8877, telefax +56 / 2 231 4294

Colombia

Arotex Colombiana S.A., Carrera 15 No.38-17
P.O. Box 050 862, Santafe de Bogota / D.C.
telephone +57 / 1 288 7799, telefax +57 / 1 285 3604

Denmark

Pfeiffer Vacuum Scandinavia AB, Vesterengen 2,
DK-2630 Taastrup,
telephone +45 / 43 52 38 00, telefax +45 / 43 52 38 50

France

Pfeiffer Vacuum France SAS
45, rue Senouque, BP 139
F-78531 BUC Cedex
telephone +33 / (0)1 30 83 04 00
telefax +33 / (0)1 30 83 04 04

Germany

Pfeiffer Vacuum GmbH,
Berliner Strasse 33, D-35614 Asslar
telephone +49 / 6441 802 400, telefax +49 / 6441 802 399
Service Hotline: +49 / 6441 802 333

Great Britain

Pfeiffer Vacuum Ltd.
2-4 Cromwell Business Centre
Howard Way, Interchange Park
Newport Pagnell, MK16 9QS, United Kingdom
telephone +44 / 1 908 500615, telefax +44 / 1 908 500616

Greece

Analytical Instruments S.A., 1 Mantzarou St.,
GR-15451 Athens,
telephone +30 / 1 674 8973, telefax +30 / 1 674 8978

Hong Kong

Pfeiffer Vacuum Asia Ltd.
Units 06-07, 17/F, Workingfield Commercial Building,
408-412 Jaffe Road, Hong Kong
telephone +852 2575 6688, telefax +852 2575 6993

India

Pfeiffer Vacuum India Ltd.
25-E Nicholson Road, Tarbundi
Secunderabad 500 009,
telephone +91 / 40 775 0014, telefax +91 / 40 775 7774

Israel

ODEM Scientific Applications Ltd.
9 Hamazera St., P.O.B. 2001 Nes Ziona
telephone +972 8 938 0333, telefax +972 8 938 0334

Italy

Pfeiffer Vacuum Italia S.p.a.
Via San Martino, 44 1-20017 RHO (Milano)
telephone +39 / 2 93 99 051, telefax +39 / 2 93 99 05 33

Japan

Hakuto Co. Ltd., C.P.O. Box 25,
Vacuum Scientific Instruments Division
C.P.O. Box 25, Tokyo 100-91
telephone +81 / 3 32 258 910, telefax +81 / 3 32 259 011

Korea

Pfeiffer Vacuum Korea Ltd.,
703 Ho, 853-1, Hankuk Mulru, Dongchonri, Suji-Eup,
449-843 Yong-in City, Kyungkido
telephone +82 / 31 266 0741, telefax +82 / 31 266 0747

Netherlands

Pfeiffer Vacuum Nederland BV
Veldzigt 30a, NL-3454 PW De Meern,
telephone +31 / 30 6666050, telefax +31 / 30 6662794

Peru

Ing. E. Brammertz s.r.l., José Pardo 182,
Apartado 173, PE-18 Miraflores,
telephone +51 / 1 445 8176, telefax +51 / 1 445-1931

Poland

Softtrade Sp.z.o.o, ul. Grunwaldzka 391,
PL-80-173 Poznan, telephone +48 / 61 8677 168,
telefax +48 / 61 8677 111

Portugal

Unilaser Lda, Taguspark
Núcleo Central, sala n° 268, Estrada Cacém-
Porto Salvo, P-2780 Oeiras
telephone +351 / 1 421 7733, telefax +351 / 1 421 7744

Singapore

APP Systems Services Pte. Ltd, 2 Corporation Road
06-14 Corporation Place, Singapore 618494,
telephone +65 / 268 2024, telefax +65 / 268 6621

Spain

Tecnovac
Tecnología de Vacío S.L., Ronda de Poniente, 6 Bajo F,
Centro Empresarial Euronova,
E-28760 Tres Cantos (Madrid)
telephone +34 / 91 804 11 34, telefax +34 / 91 804 30 91

Sweden

Pfeiffer Vacuum Scandinavia AB
Johanneslundsvägen 3
S-194 61 Upplands Väsby
telephone +46 / 590 748 10, telefax +46 / 590 748 88

Switzerland

Pfeiffer Vacuum Schweiz S.A.
Föhrlihubckstraße 30, CH-8005 Zürich
telephone +41 / 1 444 2255, telefax +41 / 1 444 2266

South Africa

Labotec Pty Ltd., P.O. Box 6553,
Halfway House
1685 Midrand
telephone +27 / 11 315 5434, telefax +27 / 11 315 5882

Taiwan

HAKUTO Taiwan Ltd. Hsinchu office No. 103,
Hsien Chen 11th Street, Chupei,
HsinChu County, Taiwan, R.O.C.
(zip/postal code: 302)
telephone +886 / 3 554 1020, telefax +886 / 3 554 0867

Thailand

Hakuto (Thailand) Ltd.
18th Floor, Chokchai Intil Bldg.
690 Sukhumvit Road
Klongton, Klongtoey
Bangkok 10110
telephone +662 / 259 6244, telefax +662 / 259 6243

U.S.A.

Pfeiffer Vacuum, Inc.
24 Trafalgar Square
Nashua, NH 03063-1988
USA
telephone +1/ 603 578 6500, telefax +1/ 603 578 6500

Venezuela

Secotec S.A., Apartado 3452, Caracas 1010-A,
telephone +58 / 212 573 8687
telefax +58 / 212 573 1932

Other countries

AVI - Applied Vacuum Industries GmbH
Leginglenstrasse 17A; CH-7320 Sargans
Switzerland
telephone +41 / 81 710 03 80
telefax +41 / 81 710 03 81

Scope of represented countries

Armenia, Azerbaijan, Bangladesh, Belarus, Bulgaria,
Cambodia, Estonia, Georgia, Kazakhstan, Kingdom of
Nepal, Kirghizia, Latvia, Lithuania, Maldiva,
Philippines, P.R. China, Rumania, Russia, Tajikistan,
Turkmenistan, Ukraine, Uzbekistan, Vietnam

A.E.M.S.

Advanced Equipment Materials and Systems
P.O. Box 25
Föhrenweg 18
FL-9496 Balzers
telephone +423/ 380 0550
telefax +423/ 380 0551

Scope of represented countries

Bahrain, Egypt, Iraq, Iran, Jordan, Kuwait, Lebanon,
Lybia, Oman, Pakistan, Saudi-Arabia, Sudan, Syria,
Turkey, United Arab Emirates, Yemen

Pumping Operations With DCU

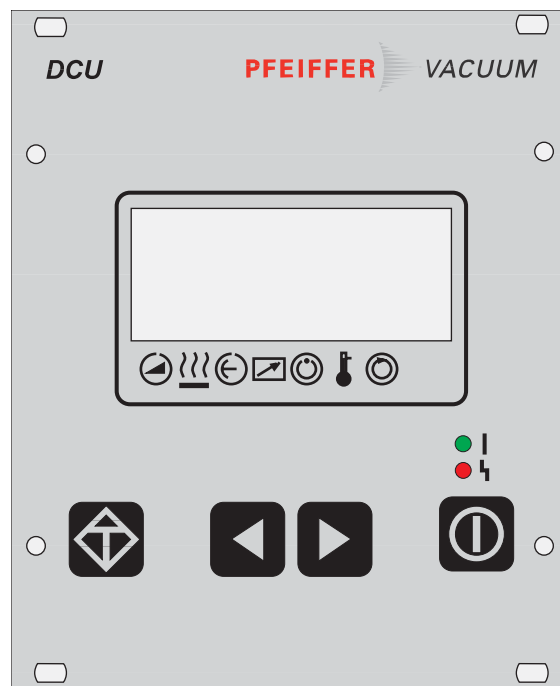

- Turbomolecular Pumps -

Index

	Page
1. Introduction To These Instruction.....	3
2. Parameters	4
2.1. General	4
2.2. Parameter Overview, Numeric DCU	4
2.3. Parameter Overview, Operations Orientated	5
3. Pumping Operations	6
3.1. General	6
3.2. Switching On The DCU.....	6
Self-Testing	6
3.3. Short Overview, Operating	6
3.4. Switching On The Pumping Station	7
Operations with mains voltages 90 - 132V	7
3.5. Switching Stand-By ON And OFF	7
3.6. Switching The Casing Heating ON And OFF	7
3.7. Sealing Gas Valve Operations	7
3.8. Operations With The Temperature Management System (TMS)	8
3.9. Gas Type Dependent Operations	8
3.10. Switching The Turbopump ON And OFF.....	9
3.11. Setting Rotation Speed Switch Point.....	9
3.12. Rotation Speed Setting Mode	10
3.13. Pressure Measurement	10
3.14. Backing Pump Operations.....	10
3.15. Switching Off The Pumping Station	11
3.16. Remote Control.....	11
Operating Modes With The Remote Control	11
Standard Remote Control	11
Remote Control Priority.....	11
Remote Control "malfunction acknowledgement"	12
3.17. Venting The Turbopump.....	12
3.18. Operations Via Serial Interface RS 485	13
3.19. Emergency Power Operations.....	13
3.20. Brake Mode (only with TC 600)	13
3.21. Configuration Of The Accessories Input And Output (only TC 100).....	13
3.22. Configuration of The Analog Output (only TC 100).....	13

	Page
4. Error Codes	14
4.1. General	14
4.2. Errors During Self-Testing	14
4.3. Errors During Operations With The TC 600.....	14
4.4. Warnings	15
5. Supplementary Information	15

Pictogram Definitions



Warning!
Danger of an electric shock.



Warning!
Danger of personal injury.



Caution!
Danger of damage to the unit or system.



Please Note!
Attention to particularly important information on the product, handling the product, or to a particular part of the documentation.

Used Abbreviations

DCU	Operation and Display Unit
TC	Electronic Drive Unit
TCK	Electronic Drive Unit (Print Modul)

Please note

Current operating instructions are also available via www.pfeiffer-vacuum.net under "infoservice".

1. Introduction To These Instructions

The Display Control Unit DCU is a universal operating unit for the control and monitoring of PFEIFFER vacuum pumps.

These operating instructions describe the operations in respect of PFEIFFER VACUUM turbomolecular pumps. This manual is a component of the complete operating manual for your modular turbopump system. Depending on the configuration of your system, other operating instructions are included in your delivery consignment (please see the table).

We make every effort to ensure that you are in possession of all the necessary product information but should anything be missing please get in touch with your local PFEIFFER VACUUM representatives or telephone the hotline number which you will find on the back cover of these operating instructions.

The respective documents are also available in PDF file format via the homepage www.pfeiffer-vacuum.de.

The following operating instructions are available for the TC pump program:

Product	Definition	Operating Manual Number
Turbomolecular Drag Pump	Definition of the turbopump	dependent on the type of pump*
Pumping operations with the DCU, turbopumps	Operating definitions /parameters	PM 800 547 BE
DCU 001, 100-600	Description of the control unit/installation	PM 800 477 BE
TPS 100, 200, 300, 600	Description of the power pack	PM 800 521 BE
Casing heating, turbopump	Description of the casing heating	PM 800 542 BE
Air cooling, turbopump	Description of the air cooling system	PM 800 543 BE
Water cooling, turbopump	Description of the water cooling system	PM 800 546 BE
Backing Pump relay box	Description of the backing pump control	PM 800 544 BE
Temperature Management System TMS	Description of the TMS installation	PT 0099 BE
Pfeiffer protocol RS 232/RS 485	Description of the serial interface protocol	PM 800 488 BE
Level Converter RS 232/RS 485	Description of the pumping control via the RS 232	PM 800 549 BE
TVF 005	Description of the venting valve	PM 800 507 BE
TIC 250	Description of the Profibus	PM 800 599 BE
PWM-Box	Description of the pulse width modulation	PM 800 563 BE
TCS 010	Description of the Pumping Station Control Unit	PT 0045 BE
Cover IP 54 for TC 600	Description of the water protection cover	PT 0024 BE
TBC 600	Description of the brake unit	PT 0018 BE

* The number is available from PFEIFFER VACUUM Service or from the internet address shown in this manual.

2. Parameter

2.1. General

All function relevant elements of the display control unit or pump are available in the DCU in the form of parameters. Each parameter has a parameter number and a clear text designation, for example **[P:026]** «OpMode TMP».

The value of the parameter is always readable and in some instances can be altered. In principle there are three different types of parameter:

Parameter Typ	Function
Setting command	Activating/deactivating a parameter
Status request	Parameter status request (readable only)
Set value standard	Altering a parameter

To adapt these parameters to the individual requirements of the user, the DCU provides two different parameter sets which are distinguished by the number of parameters involved. The respective parameter set is selected via **[P:794]** «Param. set». The parametering is always active.

Parameter Set	Comment	Setting [P:794] «Param. set»
Basic parameter set	Only parameters sorted according to number and parameter type	0
Extended parameter set	Complete parameter set, sorted according to number and parameter type	1

Parameters which do not appear in the display can nevertheless be operated via the serial interface.

2.2. Parameter Overview, numerical, DCU

Setting Commands (readable and writable)								Data type ²⁾	TC 600/750	TC 100/TCK 100
#	Display	Name, Description	min	max	fact. setting	RS 485 ¹⁾				
001	Heating	Pre-selection, heating ON/OFF	OFF	ON	OFF	R/W	0	•	•	
002	Standby	Standby ON/OFF	OFF	ON	OFF	R/W	0	•	•	
004	RUTime ctr	Run-up time monitoring, ON/OFF	OFF	ON	ON	R/W	0	•	•	
009	Error ackn	Error acknowledgement			-	W	0	•	•	
010	Pump stat	Pumping station ON/OFF	OFF	ON	ON(*)	R/W	0	•	•	
012	Vent enab	Venting enable ON/OFF	OFF	ON	ON(*)	R/W	0	•	•	
013	Brake enab	Pre selection brake ON/OFF	OFF	ON	OFF	R/W	0	•	-	
023	Motor TMP	Motor Turbopump ON/OFF	OFF	ON	ON(*)	R/W	0	•	-	
024	Conf. Out1	Configuration output K1; 0=switchpoint attained; 1= TMS regulator; 2=var. switchp.	0	2	0	R/W	7	•	-	
025	OpMode BkP	Operations mode backing pump, 0=non-stop; 1=intermittent; 2=switch on delayed	0	2	0	R/W	7	•	•	
026	OpMode TMP	Operations mode TMP 0=final rot. speed op.; 1=rot. speed setting m.	0	1	0(*)	R/W	7	•	•	
027	Gas mode	Gas mode 0=heavy inert gases; 1=other gases	0	1	0	R/W	7	•	•	
028	Opmode rem	Remote operations mode 0=standard, 1=Remote priority, 2 Remote error acknowl.	0	2	0	R/W	7	•	•	
029	OpMode Drv	Drive unit operations mode OFF=max., ON=reduced power intake	OFF	ON	OFF	R/W	0	•	•	
030	Vent mode	Venting mode 0=controlled venting ; 1=no venting; 2=venting "On"	0	2	0	R/W	7	•	•	
032	Conf Out4	Configuration heating output; 0=Heat/TMS operations; 1=sealing gas valve control	0	1	0	R/W	7	•	-	
035	Conf I/O1	Configuration accessories ON/Output 1 (see chapter 3.21)	0	3	0	R/W	7	-	•	
036	Conf I/O2	Configuration accessories ON/Output 2 (see chapter 3.21)	0	3	1	R/W	7	-	•	
055	Conf AO1	Configuration Analog Output 1 0=Rot Speed; 1=Power; 2=Current	0	2	0	R/W	7	•	•	
Status request (only readable)								Type ²⁾	TC 600/750	TC 100
#	Display	Name, Description	min	max	fact. setting	RS 485				
300		Unit remote controlled, not choosable by			-	R	0	•	•	
301	Oil defec	Oil deficiency turbopump	-	-	-	R	0	•	-	
302		Rotation switch point attained			-	R	0	•	•	
303	Error code	Actual error code „no Err“, „Errxxx“ or „Wrnxxx“			-	R	4	•	•	
304		Over temperature Electronic drive unit			-	R	0	•	•	
305		Over temperature turbopump			-	R	0	•	•	
306		Set rotation speed attained			-	R	0	•	•	
307		Turbopump accelerates			-	R	0	•	•	
308	Set rotspd	Set rotation speed TMP in Hz	0	2000	-	R	1	•	•	
309	Act rotspd	Actual rotation speed TMP in Hz	0	2000	-	R	1	•	•	
310	TMP I-Mot	Motor current TMP in A	0	15.0	-	R	2	•	•	
311	TMP Op hrs	Operating hours TMP in h (pump preset time)	0	99999	-	R	1	•	•	
312	Drv Softw	Software version electronic drive unit			-	R	4	•	•	
313	TMP DClink	Motor voltage TMP in V	0	200.0	-	R	2	•	•	
314	Drv Op hrs	Operating hours electronic drive unit	0	99999	-	R	1	•	•	
315	TMP finspd	Final rotation speed TMP in Hz	0	2000	-	R	1	•	•	
316	TMP power	Motor power TMP in W	0	1000	-	R	1	•	•	
319	Cycl count	Cycle counter	0	99999	-	R	1	•	•	
331	TMS ActTmp	Heating TMS, actual value in °C	5	200	-	R	1	•	-	
333	TMS steady	TMS regulator engaged ON/OFF	OFF	ON	-	R	0	•	-	
334	TMS maxTmp	Maximum TMS temperature occurred in °C	5	200	-	R	1	•	-	
335	Heat type	Heating type 0=conventional heating, 1=TMS	0	1	-	R	7	•	-	
340	Pressure	Actual pressure value in mbar ³⁾	1E-10	1E3	-	R	3	-	-	
349	Drv Name	Unit type electronic drive unit			-	R	4	•	•	
350	Ctr Name	Unit type operating and display unit ³⁾			-	R	4	-	-	
351	Ctr Softw	Software version Display and Control Unit DCU ³⁾			-	R	4	-	-	
360	Past Err1	Error storage, Position 1 (last error occuring)			-	R	4	•	•	
361	Past Err2	Error storage, Position 2			-	R	4	•	•	
362	Past Err3	Error storage, Position 3			-	R	4	•	•	
363	Past Err4	Error storage, Position 4			-	R	4	•	•	
364	Past Err5	Error storage, Position 5			-	R	4	•	•	
365	Past Err6	Error storage, Position 6			-	R	4	•	•	
366	Past Err7	Error storage, Position 7			-	R	4	•	•	
367	Past Err8	Error storage, Position 8			-	R	4	•	•	
368	Past Err9	Error storage, Position 9			-	R	4	•	•	
369	Past Err10	Error storage, Position 10			-	R	4	•	•	
Set values (readable and writable)								Type ²⁾	TC 600/750	TC 100
#	Display	Name, Description	min	max	fact. setting	RS 485				
700	TMP RUTime	maximum run-up time in mins	1	120	15 ⁴⁾ / 8 ⁵⁾	R/W	1	•	•	
701	Switch pnt	Rotation speed switchpoint in %	50	97	80	R/W	1	•	•	
704	TMSheatset	TMS heating temperature set value in °C	30	90	40	R/W	1	•	-	
707	TMPProt set	Rotation speed set value in rotation speed setting operations in %	20.0	100.0	50.0(*)	R/W	2	•	•	
708	DrvPwr set	Drive power set in %	10	100	80	R/W	7	•	•	
710	BKP Poff	Pmin for backing-pump interval operations [W]	0	1000	0	R/W	1	•	•	
711	BKP Pon	Pmax for backing-pump interval operations [W]	0	1000	0	R/W	1	•	•	
717	Stbyrotsset	Rotation speed set value at standby operations (%)	20	100	66	R/W	2	•	•	
719	Switch pnt2	Rotation speed switchpoint2 in %	5	97	20	R/W	1	•	•	
720	Vent frequ	Venting frequency as a % of the final rotation speed of the TMP	40	98	50	R/W	7	•	•	
721	Vent time	Venting time in s	6	3600	3600	R/W	1	•	•	
738	Gaugetype	Vacuum pressure gauge type ³⁾			-	R/W	4	-	-	
794	Param. set	Parameter set 0 = basic parameter set; 1 = extended parameter set ³⁾	0	1	0	R/W	7	-	-	
795	ServiceLin	insert service line			795	R/W	7	-	-	
797	Address	Unit address	1	255	1	R/W	1	•	•	

(*) Function can only be affected via remote plug (X16)

A number/parameter in bold type is a basic parameter set.

= Parameter setting is saved internal and activated after re-switching on.

1) R = Parameter readable via interface /W = parameter writeable via interface.

2) See Interface instruction "Pfeiffer Protocol RS 232/485" / PM 800 488 BN

3) Parameter only for DCU

4) TC 600/750

5) TC 100/TCK 100

2.3. Parameter Overview, Operations Oriented, DCU

#	Display	Name, Description	min	max	fact. set	RS 485	Sect.
Run-up time and rotation speed switchpoint							
004	RUTime ctr	Run-up time monitoring, 0=OFF; 1=ON	OFF	ON	ON	•	3.4.
700	TMP RUTime	maximum run-up time in mins	1	120	15 / 8	•	3.4.
701	Switch pnt	Rotation speed switchpoint in %	50	97	80	•	3.4.
719	Switch pnt2	Rotation speed switchpoint 2 in %	5	97	20		3.11.
General operating information							
315	TMP finspd	Final rotation speed TMP in Hz	0	2000	–	•	3.4.
310	TMP I-Mot	Motor current TMP in A	0	15.0	–	•	3.4.
313	TMP DClink	Motor voltage TMP in V	0	200.0	–	•	-
316	TMP power	Motor power TMP in W	0	1000	–	•	-
311	TMP Op hrs	Operating hours TMP in h	0	99999	–	•	3.1.
Operating adjustment turbopump							
002	Standby	Standby ON/OFF	OFF	ON	OFF(*)	•	3.5.
010	Pump stat	Pumping station ON/OFF	OFF	ON	–	•	3.4.
023*	Motor TMP	Motor Turbopump ON/OFF	OFF	ON	–	•	3.10.
026	OpMode TMP	Operations mode TMP 0=final rot. speed oper., 1=rot. speed setting	0	1	0	•	3.11.
027	gas mode	Gas mode 0=heavy inert gases; 1=other gases	0	1	0	•	3.8.
029	OpMode Drv	Operating mode drive unit OFF=max., ON=reduced power consumption	OFF	ON	OFF	•	3.4.
308	Set rotspd	Set rotation speed TMP in Hz	0	2000	–	•	3.4.
309	Act rotspd	Actual rotation speed TMP in Hz	0	2000	–	•	3.1.
717	Stbyrotsset	Rotation speed set value at standby operations (%)	20	100	66	•	
707	TMProt set	Rotation speed set value in rotation speed setting operations in (%)	20.0	100.0	50.0(*)	•	3.11.
Heating/cooling turbopump							
001	Heating	Pre-selection, heating. 0=OFF; 1=ON	0	1	0(*)	•	3.6.
032	Conf Out4	Configuration heating output; 0=Heat/TMS operations; 1=sealing gas valve control	0	1	0	•	3.7.
331*	TMS ActTmp	Heating TMS, actual value in °C	5	200	–	•	3.8.
333*	TMS steady	TMS regulator engaged ON/OFF	OFF	ON	–	•	3.8.
334*	TMS maxTmp	Maximum TMS temperature occurred in °C	5	200	–	•	-
335*	Heat type	Heating typ 0=conventional heating, 1=TMS, 2=cooling	0	2	–	•	3.6., 3.8.
704*	TMSheatset	TMS heating temperature set value in °C	30	90	40	•	3.8.
Vent valve controlling turbopump							
012	Vent enab	Venting enable ON/OFF	OFF	ON	ON	•	-
030	Vent mode	Venting mode 0=automatic venting ; 1=do not vent; 2=venting "On"	0	2	0(*)	•	3.15.
720	Vent frequ	Venting frequency as a % of the final rotation speed of the TMP	40	98	50	•	3.15.
721	Vent time	Venting time in s	6	3600	3600	•	3.15.
Pumping station controlling							
025	OpMode BkP	Operations mode backing pump, 0=non-stop; 1=intermittent; 2=switch on delayed	0	2	0	•	3.12.
035**	Conf I/O1	Configuration Accessories ON/Output 1 (see chapter 3.21)	0	3	0	•	3.20.
036**	Conf I/O2	Configuration Accessories ON/Output 2 (see chapter 3.21)	0	3	1	•	3.20.
340	Pressure	Actual pressure value in mbar	1E-10	1E3	–	•	3.11.
738	Gaugetype	Vacuum pressure gauge type			–	•	3.11.
710	BKP Poff	Pmin for backing-pump interval operations [W]	0	1000	0	•	
711	BKP Pon	Pmax for backing-pump interval operations [W]	0	1000	0	•	
Others							
013*	Brake enab	Preselection Brake ON/OFF	OFF	ON	OFF	•	
024*	Conf. Out1	Configuration output K1 0=switchpoint attained; 1= TMS regulator	0	1	0	•	3.8.
028	OpMode rem	Remote operations mode 0=standard, 1=Remote priority, 2 Remote error acknowl.	0	2	0	•	3.14.
055	Conf AO1	Configuration Analogue Output 1	0	2	0	•	3.19.
303	Error code	Actual error code „no Err“, „Errxxx“ oder „Wrnxxx“			–	•	–
312	Drv Softw	Software version electronic drive unit			–	•	–
351	Ctr Softw	Software version Display and Control Unit			–	•	–
794	Param. set	Parameter set 0=basic parameter set; 1=extended parameter set	0	1	0	•	3.4.-3.15.
795	Servicelin	insert serviceline			795	•	PM477BD
797	Address	Unit address	1	255	1	•	–
Table of failures							
360	Past Err1	Error storage, Position 1 (last error occuring)			–	•	4.3.
361	Past Err2	Error storage, Position 2			–	•	4.3.
362	Past Err3	Error storage, Position 3			–	•	4.3.
363	Past Err4	Error storage, Position 4			–	•	4.3.
364	Past Err5	Error storage, Position 5			–	•	4.3.
365	Past Err6	Error storage, Position 6			–	•	4.3.
366	Past Err7	Error storage, Position 7			–	•	4.3.
367	Past Err8	Error storage, Position 8			–	•	4.3.
368	Past Err9	Error storage, Position 9			–	•	4.3.
369	Past Err10	Error storage, Position 10			–	•	4.3.
* only for TC 600/750							
** only for TC 100 / TCK 100							
(*) Function can only be affected via remote plug (X16)							
• Function can be called by RS 485							

3. Pumping Operations

3.1. General

On delivery the pre-set basic parameter sets contain the following parameters:

Setting Command [P:0xx]	Status Request [P:3xx] (readable only)	Set Value Standard [P:7xx]
001: Heating (ON/OFF)	308: Set rotation speed, TMP (in Hz)	700: maximale Anlaufzeit (in min)
002: Stand-by (ON/OFF)	309: Actual rotation speed TMP (in Hz)	701: Schaltpunkt (in %)
	310: TMP Motor current (in A)	794: Parametersatz
	311: operating hours, TMP (in h)	

On delivery, parameter [P:794] «Param. Set» has been preset to the value "0" (basic parameter set). By setting the value to "1" you access the extended parameter set.

3.2. Switching On The DCU

➔ Make the connection to the Serial Interface RS 485.

DCU 001:

➔ Switch on the external voltage supply to the TOC.

DCU 100/150/200/300/600:

➔ Switch on the DCU with switch S1 on the rear panel.

Self Testing

After switching on, the DCU performs a self-test and also a test on the connected turbo electronics. During the test a bar appears in the display in line 4 and this shows the progress of this procedure.

Display test: All signs in the LC display are shown for a short time in black.

LEDs test: During the whole testing procedure the red and the green LEDs illuminate.

DCU self-test: The DCU hardware tests itself.

Testing the connection to the turbo electronics: The correct connection to the turbo electronics and their identity are checked.

Parameter test: Information regarding the parameters is loaded.



Identification of the connected components: The designation of the drive unit is displayed.

Providing there are no errors the DCU is now ready to operate.

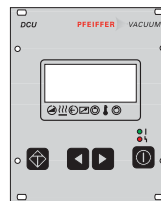
3.3. Short Overview Operation







Selecting Parameters

➔ Selecting parameters with push-button  (backwards) or  (forwards). keeping the key depressed enables rapid scrolling.

Setting Parameters

➔ Select Parameter.

➔ Depress key-button  and  simultaneously till an arrow (--->) will appear in the second line from the top.
→ Arrow disappears, if there is no setting after 8 sec..

➔ With key-button  reduce the value and with key-button  increase the value.

➔ Depress key-button  and  simultaneously till the arrow (--->) disappears.
→ The Parameter is set.

Error acknowledgement

➔ Depress key-button  for a duration of min. 2 seconds.

For a more comprehensive description please refer to the operating instructions for the DCU / PM 800 477 BN.

3.4. Switching The Pumping Station ON/OFF

Please Note:

Before switching on the pumping station the set value [P:7xx] and setting commands [P:0xx] should be checked for their suitability with regard to the selected pump and pumping process.

- ➔ Remove the remote plug on the TC (only TC 600).
- ➔ Switch on switch S1 on the mains power unit.
- ➔ Select «794 : Param. Set» and set to «1».
- ➔ Check the relevant set value standards and setting commands (Section 2.2.).
- ➔ Select «023 : motor TMP» and set to «ON» (only TC 600).
- ➔ Switch on the pumping station with key  on the DCU or via the serial interface remote control or Parameter [P:010] «Pump stat» on the DCU.

Start-up of the turbopump

After successful completion of the self test, the turbopump starts up and the backing pump is driven. The rotation speed switchpoint [P:701] must be attained within the pre-set start-up time [P:700]. Both parameters can be matched to the process. If an error code is displayed please refer to the error code table in section 4.

When the error is acknowledged the start-up time is reset.

Operations with mains voltages 90 - 132V



In case of this rated voltage the output power of the TPS (power supply) or DCU 600 (Control unit with power supply) is reduced.

Therefore the power input of the pump must be adapted with the DCU and via the parameters [P:029] and [P:708].

- ➔ Select «794 : Param. Set» and set to «1».
- ➔ Select «029 : OpMode drv».
- ➔ Set to «1» = reduced power take-up TC600.
- ➔ Select «708 : DrvPwr Set» and adjust to the relating pump type (see table below).

Pump type	Adjustment [P:708]
1001/1601/2201	80%
1201/1501/1801/2101/2301	60%

If the TC is not set the error code «E001» or «F007» is displayed.

3.5. Switching Stand-By ON/OFF

- ➔ Select «002 : Standby».
- ➔ Select «OFF» oder «ON».

“Stand-by mode” is the operation of the pump at 66% of its final rotation speed (factory setting). This value is changeable.

- ➔ Select «717 : Stbyrotset».
- ➔ Adjust Standby rotation speed in the range of 20-100%.

Stand-by is recommended during operating breaks. The function can also be selected via the remote control or the serial interface.

During activ stand-by the rotation speed set point [P:707] refers always to the adjusted stand-by rotation speed [P:717].

Stand-by mode is not possible in rotation speed setting mode (please see section 3.12).

At stand-by mode, pumps with integrated oil pump are first accelerated to 60% of their nominal rotation speed even if the set stand-by rotation speed is $<60\% \times f_{nom}$.

During this time the final rotation speed ist shown via [P:308] «set rotation speed». After reaching 60% of speed the adjusted stand-by rotation speed is displayed [P:717].

3.6. Switching The Casing Heating ON/OFF

The TC 600 automatically recognizes a connected casing heating and sets according to the parameters [P:355] «Heat type» to «0». If no heating is connected «1» is displayed.

To control the casing heating on the TC 100/TCK 100 it is necessary to select the respective accessory input and output (see section 3.21.)

- ➔ Select «794 : Param. Set» and set to «1».
- ➔ Select «335 : Heat type» and check setting to «0».
- ➔ Select «001 : Heating».
- ➔ Select «OFF» or «ON».

The casing heating is switched on and off dependent on the rotation speed switchpoint. Undershooting the rotation speed switchpoint causes the heating to be switched off. The status of the casing heating can be seen on the LC display on the DCU.

The function “casing heating” can be called up either via the serial interface or the remote control.

3.7. Sealing Gas Valve Control

Operation of the heating output "Heat/TMS" may be configured through [P:032]. At this output also a sealing gas valve may be driven by a venting valve.

- ➔ Select «794 : Param. Set» and set to «1».
- ➔ Select «032 : Conf Out4» and set to «1».

A valve connected to the connection "Heat/TMS" can be switched on at any time independently only through [P:001] or the corresponding control input "Heating ON" at the remote connector.

- ➔ Select «001 : Heating».
- ➔ Choose «OFF» or «ON».

3.8. Operations With Temperature Management System (TMS) (only TC 600/750)

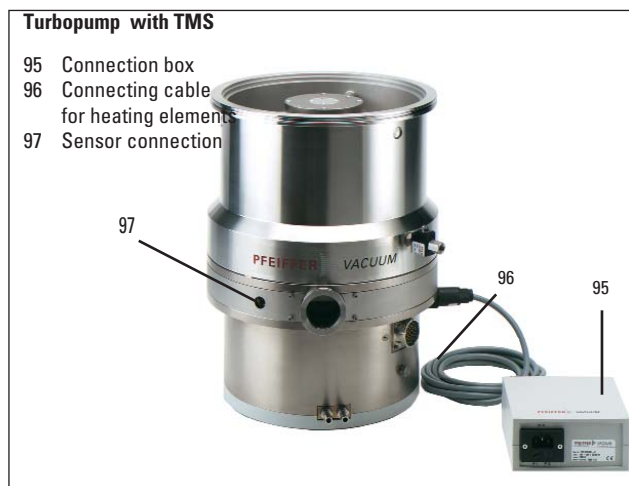

The Temperature Management System (TMS) comprises a regulatable heating system which is installed in the fore-vacuum part of the turbomolecular pump. Heating up to a maximum of 90°C prevents the condensation of process gases or by-products in this part of the pump.

As a matter of principle, the TMS heating is only activated on attainment of the rotation speed switchpoint [P:701]. The TC 600 automatically recognizes a connected TMS heating unit and sets the parameter [P:335] «Heat type» to «1».

Activating TMS mode

- ➔ Select «794 : Param. Set» and set to «1».
- ➔ Select «335 : Heat type» and check setting.
- ➔ Select «704 : TMSheatset».
- ➔ Enter set temperature value «30°C...90°C».
- ➔ Acknowledge the value.
- ➔ Select «001 : Heating» and set to «1».

With [P:001] «Heating» The TMS heating can be activated and deactivated at any time with «1» or «0» respectively.

In addition to the above parameters (which are used to start the TMS) other parameters are also available to support working with the TMS:

Calling up the TMS temperature

- ➔ Select «331 : TMS ActTmp» and read off the temperature.

TMS set temperature attained?

- ➔ Select «333 : TMS steady» and read off the information.

Function of switch "output 1" (only TC 600)

The switch output 1 is normally set to "high" on the rotation speed switchpoint being exceeded. The function of switch output 1 can be re-programmed so that switch output 1 is "high" only when the TMS set temperature is attained.

- ➔ Select «024 : Conf. Out1» and set to «1».

This information can be used, for example, as an input signal for a higher ordered process control.

3.9. Gas Type Dependent Operations

To protect the rotors against overheating, the maximum power on some turbopumps is limited to the nominal rotation speed. Normally, with a lower, pre-set rotation speed, more power can be provided. This frequency/power curve is dependent on the type of gas.

Selecting the gas type

- ➔ Select «794 : Param. Set» and set to «1».
- ➔ Select «027 : gas mode».
- ➔ Select «0» for heavy, noble gases and «1» for other gases.

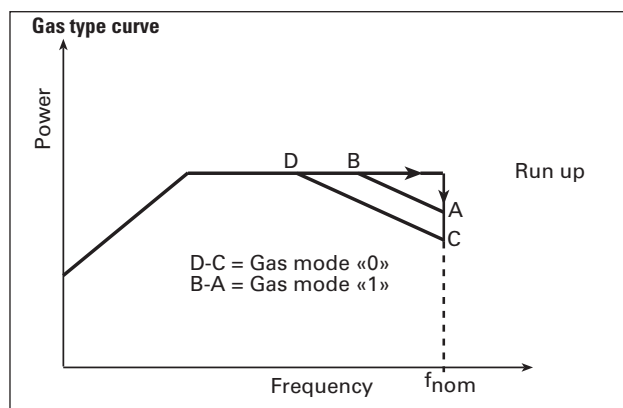

The rotation speed is reduced when the gas dependent maximum power is exceeded until there is equilibrium between the permissible power and the gas friction. To avoid rotation speed fluctuations it is recommended to set (in rotation speed setting mode) the equilibrium frequency or a somewhat lower frequency.

3.10. Switching The Turbopump ON/OFF (only TC 600/750)

During pumping station operations (pumping station "ON") the turbopump can be switched on and off separately:

- ➔ Select «023 : Motor TMP».
- ➔ Select «OFF», or «ON» as required.

3.11. Adjusting Rotation Speed Switchpoint

The speed switch point may be used to generate the message "Pump ready". As soon as the speed exceeds, respectively drops below the speed switch point 1 [P:701] «Switch pnt» the switched output is energized or de-energized. The factory default setting is 80%.

Simple Switch Point Adjustment (upper value only)

- ➔ Select «701 : Switch pnt» .
- ➔ Adjust the switch point in the range between 50-97%.
- ➔ Confirm the adjustment.

Depending on the setting of the parameter [P:024] «Conf Out1» the lower and the upper speed switch point may be influenced simultaneously.

The factory default setting is 20, respectively 80% of the final rotation speed.

Double switch point adjustment (lower and upper value)

With this function different switch points at start up or shut down can be set and evaluated.

- ➔ Select «024 : Conf Out1».
- ➔ Set the parameter to «2».
- ➔ Confirm the adjustment.

The speed switch point can now be varied through two further parameters:

Activated drive

In the case of an activated drive ([P:010] and [P:023] set to "ON") the switch point output is driven independently of the setting for the switch point 1 [P:701]. As soon as the speed exceeds the adjusted switch point, the switch point output is energized. The setting may be selected between 50 and 97% of the final rotation speed.

- ➔ Select «701 : Switch pnt».
- ➔ Adjust the switch point in the range between 50-97%.
- ➔ Confirm the adjustment.

Deactivated drive

In the case of a deactivated drive ([P:010] and [P: 023] set to "OFF") the switch point output is driven independently of the setting for the switch point 2 [P:719]. As soon as the speed drops below the adjusted switch point, the switch output is de-energized. The setting may be selected between 5 and 97% of full speed.

- ➔ Select «719 : Switch pnt2».
- ➔ Adjust the switch point in the range between 5-97%.
- ➔ Confirm the adjustment.

3.12. Rotation Speed Setting Mode

The rotation speed setting mode is selected if the turbopump volume flow rate should be reduced. The pressure ratio of the pump reduces exponentially with the rotation speed.

Rotation speed standard in rotation speed setting mode

- ➔ Select «794 : Param set» and set to «1».
- ➔ Select «707 : TMProt set».
- ➔ Select the rotation speed in the range from 20%.....100%.

Operating mode, turbopump

- ➔ Call up «026 : OpMode TMP».
- ➔ Select "1" for rotation speed setting mode.



The stand-by mode is ineffective in rotation speed setting mode. The rotation speed switch-point has been fixed at 20%. The rotation speed setting mode can be set via the remote control or the serial interface.

Pumps with integrated oil pumps are first accelerated, in rotation speed setting mode, to 60% of their rated rotation speed, also where the set rotation speed is $<60\% \cdot x_{f_{nom}}$.

During this time the final rotation speed is shown via [P:308] «set rotation speed». After reaching 60% of speed the adjusted stand-by rotation speed is displayed [P:717].

3.13. Pressure Measurement

With the use of a high vacuum pressure gauge the pressure in the vacuum chamber is shown in the DCU display.



Basically an exact pressure measurement is not possible by the DCU. This is especially indicated at linear working gauges in the lower pressure range. In case of doubt an intended measuring unit should be used.

The following pressure gauges are automatically recognized by the DCU:

Pressure Gauge	P _{min} [mbar]	P _{max} [mbar]
TPR 2xx	5E-4	1E+3
PKR 2xx	5E-9	1E+3
ACR 261/CMR 261/APR 250/260	1E-1	1E+3
ACR 262/CMR 262	1E-2	1E+2
ACR 263/CMR 263	1E-3	1E+1
CMR 264	1E-4	1E0

Requesting the type of pressure gauge

- ➔ Select «794 : Param set» and set to «1».
 - ➔ Select «738 : gauge type».
 - ➔ Read off the pressure gauge type.
- Some pressure gauges can only be recognized as a group (e.g. ACR 261-ACR 263) and have to be set manually.

Requesting the actual pressure value

- ➔ Select «794 : Param set» and set to «1».
- ➔ Select «340 : Pressure».
- ➔ Read off the pressure value in mbar.

The following can be displayed, depending on the pressure gauge type:

Display (Example)	Appears when
«--- mbar»	no pressure gauge is connected
«<5E-4mbar»	measuring range is non-attained (depending on the pressure gauge in use)
«>1E3mbar»	measuring range is exceeded (depending on the pressure gauge in use)
«6.3E-9mbar»	valid pressure measurement range
«idfam mbar»	pressure gauge type not yet identified
«TPR250»	pressure gauge TPR 250 connected
«ACR..?»	pressure gauge ACR 261, ACR 262 oder ACR 263 connected but not yet selected (in this case the display «idfam» [P:340] is shown)
«Error!»	error in the pressure gauge

3.14. Backing Pump Operations

The operating modes "non-stop operations", "interval operations" or "Switch ON delayed" can be selected depending on the selected backing pump and the vacuum application. Interval operations can be selected, for example, to prolong the working life of the diaphragms in diaphragm vacuum pumps. The backing pump is switched on and off depending on the power take-up of the turbopump.



Rotary vane pumps must not be used for internal operations.

Non-stop operations backing pump

- ➔ Select «**794 : Param set**» and set to «**1**».
- ➔ Select «**025 : OpMode BkP**» and set to «**0**» for non-stop operations.

Interval operations backing pump

- ➔ Select «**794 : Param set**» and set to «**1**».
- ➔ Select «**025 : OpMode BkP**» and set to «**1**» for interval operations.

For intermittent operations involving the backing pump, either a diaphragm pump with integrated semiconductor relay or a relay box with semiconductor relay should be used. The backing pump is switched on and off in accordance with the power take-up levels of the turbopump.

Differing power take-up levels on an idling turbopump lead to differing pressure switchpoints on various pumps. In addition, on diaphragm pumps there are differing final pressures resulting from the gas ballast equipment. This means that ideal pressure switchpoint setting via the power take-up level is not possible. Nevertheless, the advantage of intermittent operations can still be exploited by setting the pressure switch thresholds individually. In this respect operations between 5 and 10 mbar are recommended.

A vacuum meter, a DCU and a dosing valve are required in order to set the switching threshold. Instead of the vacuum meter a vacuum gauge can be connected directly to the DCU.

Setting the switching thresholds

- ➔ Select «**340 : Pressure**».
- ➔ Admit air into the fore-vacuum line with the dosing valve while the pumping station is running until the fore-vacuum pressure increases to 10 mbar.
- ➔ Select «**316 : TMP power**».
- ➔ Read off the take-up power at 10 mbar.
- ➔ Select «**711 : BKP Pon**».
- ➔ Save the read-off take-up power as the upper switching threshold.
- ➔ Proceed analogically with the lower switching threshold. Take 5 mbar as the pressure value.
- ➔ Select «**710 : BKP Poff**».
- ➔ Save the read-off take-up power as the lower switching threshold.

Switch On Delayed

- ➔ select «**794 : Param set**» and set to «**1**».
- ➔ select «**025 : OpMode BkP**»; choose «**2**» for delayed switch on.

When simultaneously switching on the turbopump and the backing pump, the gas flow could cause a failure with the error message **E913** during the starting phase. In order to prevent this, it is recommended to first start the turbopump and then the backing pump or open a driven fore-vacuum valve.

In the operating mode "delayed switch on" after activation of the parameter «Pump start» [**P:010**] and «Motor TMP» [**P:023**] the turbopump is started first and as soon as a speed of 6 Hz has been exceeded the backing pump controlled via the TC is then switched on.

Should the backing pump or a fore-vacuum valve be driven by a higher level system controller, it is recommended to proceed in the same way.

3.15. Switching Off The Pumping Station

➔ Depress **⓪** on the front panel. As an alternative, the pumping station can be switched off via the remote control, the serial interface or **[P:010]**.

3.16. Remote Control

The following functions can be activated via the remote control (please also refer to the operating instructions for the respective turbopump):

TC 600:

PIN	Function
2	Venting enable "ON/OFF"
3	Turbopump "ON/OFF" /remote priority "ON/OFF"
4	Pumping Station "ON/OFF"
5	Heating "ON/OFF"/Error acknowledgement
6	Stand-by "ON/OFF"
7	Rotation speed setting mode via pulse width modulation (PWM).

TC 100/TCK 100:

PIN	Function
2/d4	- Remote Priority "ON/OFF"
3/b4	- Accessory 1 "ON/OFF"
4/z4	- Accessory 2 "ON/OFF"
5/d6	- Pumping Station "ON/OFF"
6/b6	- Standby "ON/OFF" / Reset

Operating modes with the remote control

Basically there are three different possibilities with regard to the remote control with differing priorities with respect to the remote control functions:

Standard Remote Control

➔ Select **«028 : OpMode rem»** and set to **«0»**.

The individual functions which can be operated with the remote control are activated via "SPS High Level". Activated individual functions cannot be operated via the serial interface nor the keyboard. Individual functions deactivated with the remote control can be operated via the serial interface or the keyboard.

Remote Control Priority

Only TC 600:



«028 : OpMode rem» may only be altered to **«OFF»** when the pump is switched off (**«023 : Motor TMP»**).

Priority ON

In certain application cases as, for example, SPS control, the remote control functions can be assigned prioritized switching.

➔ Select **«028 : OpMode rem»** and set to **«1»**. Bridge pin 1/pin 3 on the connecting plug "remote".

→ All set functions will be switched off excepting "motor, turbopump ON" which remains on "ON".

→ The remote control functions can only be set via the connecting plug "remote". The DCU keyboard/serial interface is inactive.

The functions:

- Heating ON/error acknowledgment

- Stand-by ON

- Pumping station ON

- Enable venting

are activated and deactivated with the signals **«1»** and **«0»** respectively. In the rotation speed setting mode the set value standard is processed exclusively via pin 7 on the connecting plug "remote".

If pin 3 on the connection "remote" should be set to **«0»**:

→ Values set via the remote control will be taken over except in rotation speed setting mode. Here, the set value standard is processed via the serial interface or the keyboard.

Priority OFF

➔ Select **«028 : OpMode rem»** with $f=0$ Hz and set to **«1»**.

→ All set functions will be switched off excepting "motor, turbopump ON" which remains on "ON".

➔ Set Pin3/"Remote" to **«0»**.

→ Operating is only possible via the DCU keyboard/serial interface (remote control not active).

→ -Set values are not saved.

→ In rotation speed setting mode the rotation speed set via the keyboard or serial interface will be taken over.

If **«028 : OpMode rem»** should be re-set to **«0»**:

→ Values set via the keyboard or serial interface will be taken over. Values set with **«1»** via the remote control will also be taken over.

Only TC 100/TCK 100:

Priority ON

➔ Select «028 : OpMode rem» and set to «1».

TC 100

➔ Bridge pin 2/pin 7 on the connecting plug X3.

TCK 100

➔ Bridge pin d4/pin z28 on the connecting plug X4.

→ All set functions will be switched off.

→ The remote control functions can only be set via the connecting plug X3. The DCU keyboard/serial interface is inactive.

The functions:

- Accessory 1 ON
- Accessory 2 ON
- Pumping station ON
- Standby/Reset ON

are activated and deactivated with the signals «1» and «0» respectively.

Priority OFF

➔ Select «028 : OpMode rem» and set to «1».

➔ Remove bridge pin 2/pin 7 on the connecting plug X3.

→ Values set via the remote control will be taken over.

→ Operating is only possible via the DCU keyboard/serial interface (remote control not active).

→ -Set values are not saved.

If «028 : OpMode rem» should be re-set to «0»:

→ Values set via the keyboard or serial interface will be taken over. Values set with «1» via the remote control will also be taken over.

Remote Control "Malfunction Acknowledgement"

If the reset input on the remote control is not used, it can be utilized as an external malfunction acknowledgement via the remote control; this means that after a switch off and subsequent switch on via the "Motor TMP" or "Pumping Station" inputs, a malfunction acknowledgement will first be executed.

➔ Set «028 : OpMode rem» to «2».

3.17. Venting The Turbopump

Venting is possible after the pump has been switched off.

Basically, a delay time of 6 seconds is observed before each venting procedure to ensure that any possible high vacuum valve is closed. In a currentless state the venting valve is closed. Where a malfunction (error) is involved venting will proceed in accordance with the selected venting mode.

Three types of venting modes can be selected in the extended parameter set:

➔ Select «794 : Param set» and set to «1».

➔ TC 600: Allocate venting release via bridge PIN 1 and PIN 2 on the "remote" plug.

➔ TC 100: Allocate venting release via bridge PIN 1 and PIN 3 respectively PIN 4 (according to the output configuration).

➔ TCK 100: Allocate venting release via bridge z28 and b4 respectively z4 (according to the output configuration).

or

➔ Call up «012 : Vent enab». Select «ON».

➔ Call up «030 : Vent mode». Select «0», «1» oder «2».

Venting mode «0»: automatic venting

Automatic venting means that venting begins at a specific frequency [P:720] after the pumping station has been switched off or a mains power failure and continues for a specific duration [P:721].

In the event of a mains power failure, the set duration value cannot be guaranteed.

➔ Select «720 : Vent frequ».

➔ Set the venting frequency between «40-98%».

➔ Select «721 : Vent time».

➔ Set the venting duration in sec. between «0» and «3600».

→ The venting valve is closed after mains power has been restored.

Venting mode «1»: venting OFF

→ The pump will not be vented.

Venting mode «2»: venting ON

→ When the pumping station is switched off, in cases of malfunction and in the event of a power failure, after a time lag of 6 seconds, venting takes place. If a high vacuum valve is installed, it can be closed in the meantime. Where a mains power failure is involved, venting will only take place as long as the pump is able to supply power to the venting valve. After power has been restored the venting valve stays open. It closes when the pumping station is switched on.

3.18. Operations Via Serial Interface RS 485

The group address of the TC 600 is 960 of the TC 100/TCK 100 is 950. All units connected to the bus must have differing serial interface addresses [P:797]. The connection of an RS 232 (for example, a PC) is possible via Level Converter PM 051 054-X. The description of the data communication (PFEIFFER VACUUM protocol) can be found in Operating Instructions PM 800 488 BN.

3.19. Emergency Power Operations

If during turbopump operations the power fails (warning «F007»), the pump rotor acts as a generator and takes over the supply of power for the electronics. In addition, a power failure is signalled by flashing green and red LEDs on the front panel (50% ON; 50% OFF). At a certain rotation speed (depending on the pump), the pump energy is no longer sufficient and communication between the DCU and the TC is interrupted and error message «E698» appears.

3.20. Brake Mode (only TC 600)

In order to be able to more quickly brake the pump in rotation speed setting mode, some pumps allow the connection of an external braking system (accessory on request).

Activating brake mode

➔ Call up «013 : Brake enab»; select «ON».

De-activating brake mode

➔ Call up «013 : Brake enab»; select «OFF».



Malfunction «E002» results if the brake mode is activated and there is no connected braking system.

3.21. Configuration Of The Accessory Input/Output (only on the TC 100 with TCS 010 or TCK 100)

The following pumping station components can be connected:

- Air cooling, venting valve, heating, backing pump.

In this respect it is necessary to configure the accessory input/output in relation to the function optionally via [P:035] or [P:036].

- ➔ Select «035 : Conf. I/O1».
- ➔ Select function as required:
 - 0 = air cooling (set by factory)
 - 1 = Venting valve
 - 2 = Heating
 - 3 = Backing pump

- ➔ Select «036 : Conf. I/O2».
- ➔ Select function as required:
 - 0 = air cooling
 - 1 = Venting valve (set by factory)
 - 2 = Heating
 - 3 = Backing pump

3.22. Configuration Of The Analog Output

An analog signal (0-10 VDC) with the following information can be taken from the TC or TCK 100:

- Rotation speed of the turbopump
- Power input
- Current input.

In this respect it is necessary to configure the analog input/output in relation to the function.

- ➔ Select «055 : Conf. A01».
- ➔ Select function 0, 1 oder 2:
 - 0 = Rotation speed signal, 0-10 VDC = 0-100% x f_{end}
 - 1 = Power input signal, 0-10 VDC = 0-100% x p_{max}
 - 2 = Current supply signal, 0-10 VDC = 0-100% x I_{max}

Information about the values f_{end} , p_{max} , I_{max} are readable in the operating instructions of the additional pump.

4. Error Codes

4.1. General



Errors ("Errxxx" or Error "Exxx") always lead to shut-down of the TMP, the fan, the heating and the backing pump.

- ➔ After the error is eliminated, depress key .
- The unit is again ready to operate.

4.2. Errors During Self-Testing

The following errors can occur during self-testing performed when the DCU is switched on:

Display	Error	Possible Action
«Error E040»	Hardware error: external RAM defective	Inform PFEIFFER VACUUM-Service
«Error E042»	Hardware error: EPROM checksum	Inform PFEIFFER VACUUM-Service
«Error E043»	Hardware error: E ² PROM erratum	Inform PFEIFFER VACUUM-Service
«Error E090»	Insufficient RAM	Inform PFEIFFER VACUUM-Service
	DCU is connected to the wrong turbo electronics	Connect correct turbo electronics
«Error E698»	The connected drive unit does not respond	Check communication lead between TC and DCU, switch on TC

4.3. Errors During Operations

During operations, errors and warnings which occur are, independent of the function of the service line, always shown in the LC display and can be additionally requested in parameter [P:303] «Error code». In addition, parameters 360 to 369 retain the last ten errors or warnings which occurred.

After an error has occurred all parameters can be viewed but no longer altered. Exception: Error [E698] «TC does not respond». Here, no actualisation of the parameter is possible until the communication has been restored.

Code	Description	Occurs At	Error Elimination Action
E001	TMP excess rotation speed	B -	- Inform PFEIFFER VACUUM Service. - If operations with mains voltage 90 - 132 VAC, check settings [P:029] (see chapter 3.4)
E002	Power pack unit error	S/B	- Check power pack output voltage. - Check settings [P:013] (see chapter 3.20). - Inform PFEIFFER VACUUM Service.
E006	Start-up time error When the start-up phase is completed, the rotation speed of the pump drops below the rotation speed switchpoint.	S/B	- Set correct start-up time. - Open vacuum valve. - Reduce fore-vacuum pressure. - Eliminate leak. - Check free running of the turbo pump.
E007 ¹⁾³⁾	Operating fluid deficiency	S/B	- Check oil level. - Request status of the oil sensor via [P:301]. - Inform PFEIFFER VACUUM Service.
E008	Connection TC and pump	S/B	- Check connection TC and pump.
E014 ¹⁾	The heating type identified in the self test has been changed by pulling the plug or by an error.	B	- Change configuration of heating or cooling unit. - Inform PFEIFFER VACUUM Service.
E015	Error in the TC controller	S/B	- Reset the controller with mains ON/OFF with the pump at standstill (f=0 Hz). - Possibly Inform PFEIFFER VACUUM Service.
E021	Incorrect pump identification resistance	S	- Inform PFEIFFER VACUUM Service.
E025	Error in the temperature monitoring TC	S/B	- Reset the controller with mains ON/OFF with the pump at standstill (f=0 Hz). - Possibly Inform PFEIFFER VACUUM Service.
E026	Error of the temperatur sensor inside the TC	S/B	- Reset the controller with mains ON/OFF with the pump at standstill (f=0 Hz). - Possibly Inform PFEIFFER VACUUM Service.
E037	Error in the motor stages or control	S/B	- Possibly Inform PFEIFFER VACUUM Service.
E698	TC does not respond	S/B	- Check connection DCU - TC. - Change the DCU. - Possibly Inform PFEIFFER VACUUM Service.
E913 ²⁾	Error in the self test or when the pump starts up	S	- Error resets itself 5 times. Then switching off via «E006» - Possibly set the op. mode backing pump [P:025] up to "2" - Check the free rotation of the pump. - Possibly Inform PFEIFFER VACUUM Service.

¹⁾ only TC 600/TC750

²⁾ This error message is not displayed via switch output 2 (collective error message);

³⁾ Error acknowledgement of this failure is only possible for 5 times.
S: self test; B: operations

4.4. Warnings

Warnings ("Wrnx" or "Warning Fxxx") are only displayed and (otherwise than is the case with errors) do not cause components to be shut down.

Code	Description	Explanations
F001 ¹⁾	TMS heating start-up time elapsed	TMS heating start-up time elapsed.
F002 ¹⁾	TMS limit temperature	TMP-temperature > 100°C.
F003 ¹⁾	TMS-heating circuit temperature sensor	TMP temperature not within the range 5°C and 120°C.
F007	Mains power failure	Operations voltage has failed.
F039 ¹⁾	Protective conductor warning TC	Potential of the supply voltage in contact with the protective conductor PE
F110 ²⁾	Pressure gauge defective	Pressure gauge disconnected during operations

¹⁾ only TC 600/750
²⁾ Warning only in DCU.



Warning «F039» must be eliminated without delay otherwise there is a danger of an electric shock.

5. Supplementary Information

Information with regard to:

- Product
- Proper Use
- Installation
- Operation
- Errors
- Maintenance and Service
- Technical Data

can be found in Operating Instructions PM 800 477 BE for "Display And Operating Unit DCU" which is included in this consignment.

The PFEIFFER VACUUM protocol for Serial Interface RS 485 is described in Operating Instructions PM 800 488 BE which is included in this consignment.

Your Vacuum Technology Experts in



Turbo Pumps



Rotary Vane Vacuum Pumps



Roots Pumps



Dry Vacuum Pumps



Leak Test Units



Valves



Flanges, Feedthroughs



Vacuum Measurement



Gas Analysis



System Technology



Service

PFEIFFER  **VACUUM**

Pfeiffer Vacuum Technology AG · Headquarters/Germany

Tel. +49-(0) 64 41-8 02-0 · Fax +49-(0) 64 41-8 02-2 02 · info@pfeiffer-vacuum.de · www.pfeiffer-vacuum.net