



Vacuubrand PC 610 Select

Technical Specifications

		PC 610 select
Vacuum controller		VACUU-SELECT
Number of heads / stages		4 / 3
Max. pumping speed at 50/60 Hz	m ³ /h	3.4 / 3.8
Max. pumping speed at 50/60 Hz	cfm	2.0 / 2.2
Ultimate vacuum (abs.)	mbar/torr	1.5 / 1.1
Ultim. vac. (abs.) with gas ballast	mbar/torr	3 / 2.2
Ambient temperature range (operation)	°C	10 - 40
Ambient temperature range (storage)	°C	-10 - 60
Max. back pressure (abs.)	bar	1.1
Inlet connection		Hose nozzle DN 8-10 mm
Outlet connection		Hose nozzle DN 8-10 mm
Coolant connection		2 x hose nozzle DN 6-8 mm
Rated motor power	kW	0.25
Rated motor speed at 50/60 Hz	min-1	1500/1800
Protection class		IP 40
Dimensions (L x W x H)	mm	419 x 243 x 457
Weight	kg	20.4
Noise level at 50 Hz, typ.	dBA	45
ATEX conformity (only 230V)		II 3/- G IIC T3 X Internal Atm. only
Items supplied		Pumping unit completely mounted, ready for use, with manual.
Accessories		Coolant valve VKW-B (20674220) Vent valve VB M-B (20674217) Liquid level sensor (20699908) Rubber vacuum tubing DN 8 mm (20686001)



PROVAC

SALES

PHONE: 831-462-8900

FAX: 831-462-3536

WWW.PROVAC.COM

Vacuubrand PC 610 Select Pumping Curves

50Hz

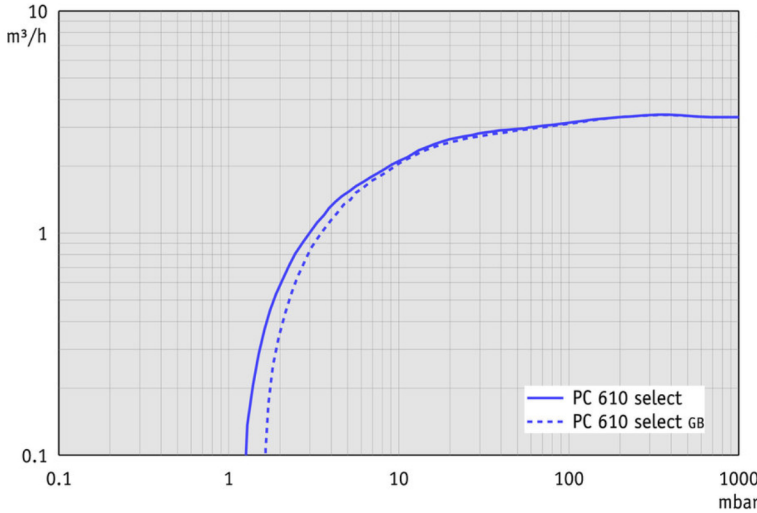

60Hz

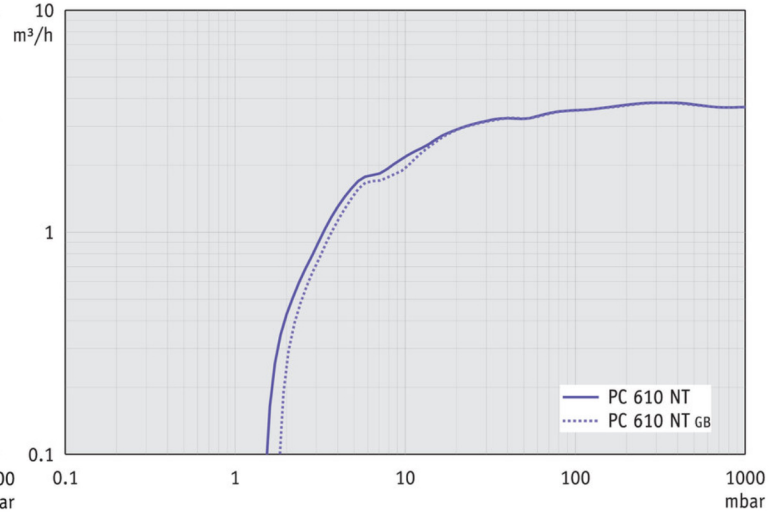

Dimensions

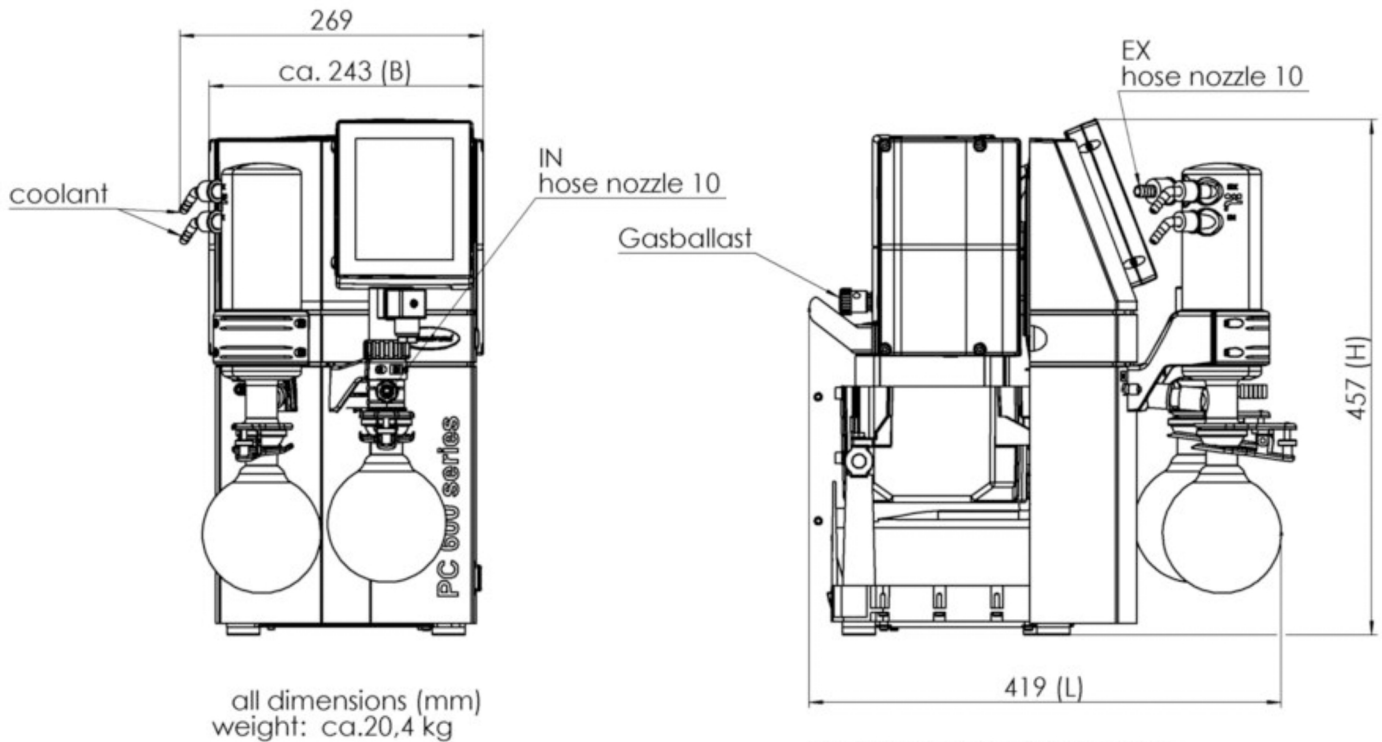

all dimensions (mm)
weight: ca.20,4 kg

VACUUBRAND PC 610 select
Version 2017/08/24



PROVAC

SALES

PHONE: 831-462-8900

FAX: 831-462-3536

WWW.PROVAC.COM

Vacuubrand PC 610 Select Features & Benefits

- excellent choice for supporting electronically controlled evaporation or drying processes with even many high boiling point solvents
- MD-4CNT 3-stage chemistry pump is the heart of this pumping unit
- integrated controller provides application based interface
- constantly monitors the pressure & switches to 2 point control mode to hold the pressure stable when a boiling point is detected
- inlet separator prevents particles & liquid droplets from entering pump
- exhaust vapor condenser provides near 100% solvent recovery

Applications

- rotary evaporators • vacuum concentrators • drying chambers
- vacuum distillation

