



# Vacuubrand PC 511 Select

## Technical Specifications

		PC 511 select
Vacuum controller		VACUU·SELECT
Number of heads / stages		2 / 2
Max. pumping speed at 50/60 Hz	m <sup>3</sup> /h	2.0 / 2.3
Max. pumping speed at 50/60 Hz	cfm	1.2 / 1.4
Ultimate vacuum (abs.)	mbar/torr	7 / 5
Ultim. vac. (abs.) with gas ballast	mbar/torr	12 / 9
Ambient temperature range (operation)	°C	10 - 40
Ambient temperature range (storage)	°C	-10 - 60
Max. back pressure (abs.)	bar	1.1
Inlet connection		2 x hose nozzle DN 8-10 mm
Outlet connection		Hose nozzle DN 8-10 mm
Coolant connection		2 x hose nozzle DN 6-8 mm
Rated motor power	kW	0.18
Rated motor speed at 50/60 Hz	min-1	1500/1800
Protection class		IP 40
Dimensions (L x W x H)	mm	435 x 243 x 457
Weight	kg	17.4
Noise level at 50 Hz, typ.	dBA	45
ATEX conformity (only 230V)		II 3/- G IIC T3 X Internal Atm. only
Items supplied		Pumping unit completely mounted, ready for use, with manual.
Accessories		Coolant valve VKW-B (20674220) Vent valve VB M-B (20674217) Liquid level sensor (20699908) Rubber vacuum tubing DN 8 mm (20686001)



# PROVAC

## SALES

PHONE: 831-462-8900

FAX: 831-462-3536

WWW.PROVAC.COM

# Vacuubrand PC 511 Select Pumping Curves

### 50Hz

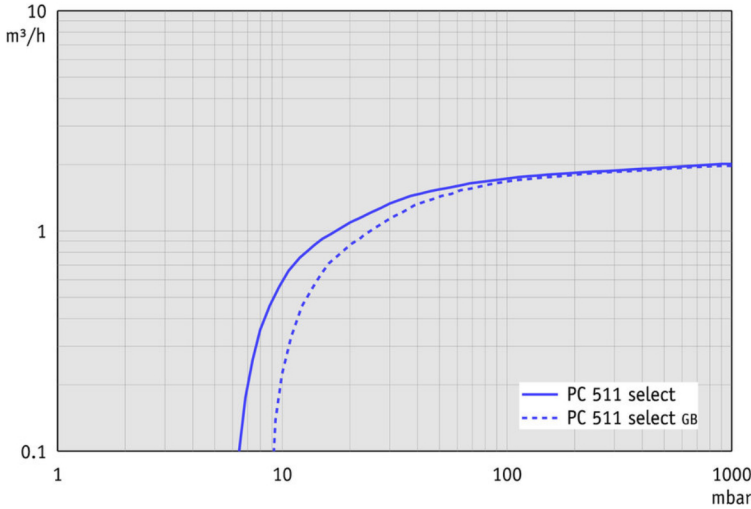

### 60Hz

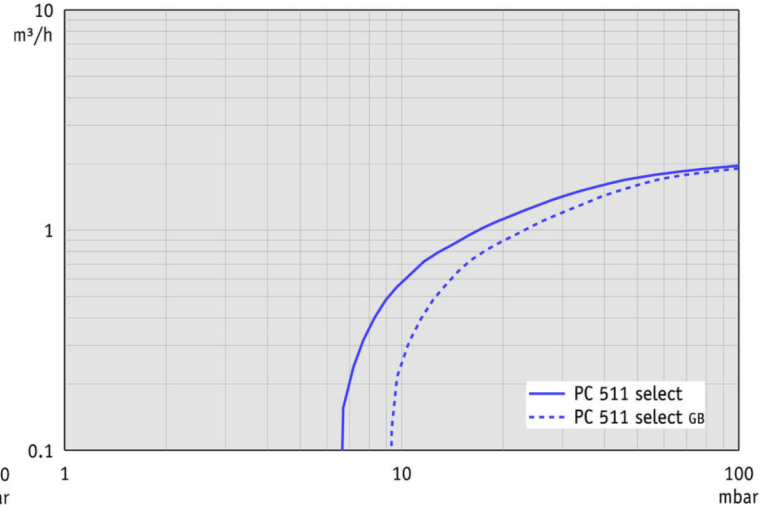

## Dimensions

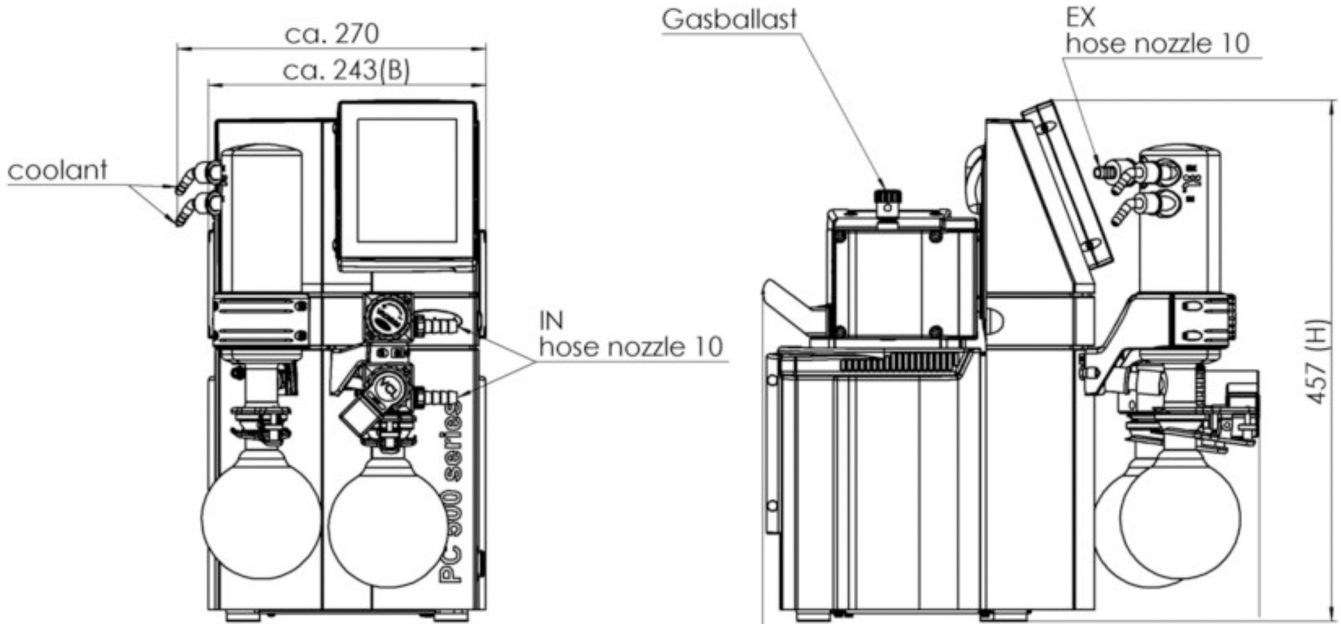

all dimensions (mm)  
weight: ca.17,4 kg

VACUUBRAND PC 511 select  
Version 2017/08/07



# PROVAC

## SALES

PHONE: 831-462-8900

FAX: 831-462-3536

WWW.PROVAC.COM

## Vacuubrand PC 511 Select Features & Benefits

- economical, compact solution for simultaneously running two independent applications with one pump
- MZ-2CNT is the heart of the pumping unit
- vacuum controller features graphical user interface
- electronically controlled port detects boiling pressure & switches to 2 point control to hold pressure steady when boiling point is detected
- a second, manually controlled vacuum port permits simultaneous operation of a second vacuum application on the same pump
- inlet separator prevents particles & liquid droplets from entering pump
- exhaust vapor condenser allows for near 100% solvent recovery when used with a chilled water line/recirculating chiller
- excellent chemical & condensate capability

## Applications

- rotary evaporators • vacuum concentrators • gel dryer • drying chambers

