



# OPERATING INSTRUCTIONS

EN

Translation of the original instructions

## MVP 020-3 AC

Diaphragm Pumps

**PFEIFFER**  **VACUUM**

# Table of contents

<b>1</b>	<b>About this manual</b> .....	<b>3</b>
	1.1 Validity .....	3
	1.2 Conventions .....	3
<b>2</b>	<b>Safety</b> .....	<b>4</b>
	2.1 Safety precautions .....	4
	2.2 Proper use .....	5
	2.3 Improper use .....	5
<b>3</b>	<b>Transport and storage</b> .....	<b>6</b>
	3.1 Transport .....	6
	3.2 Storage .....	6
<b>4</b>	<b>Product description</b> .....	<b>6</b>
	4.1 Product identification .....	6
	4.2 Function .....	7
<b>5</b>	<b>Installation</b> .....	<b>8</b>
	5.1 Setting up the pump .....	8
	5.2 Connecting the vacuum side .....	8
	5.3 Connecting the exhaust side .....	8
	5.4 Connecting to the mains power supply .....	9
<b>6</b>	<b>Operation</b> .....	<b>11</b>
	6.1 Before switching on .....	11
	6.2 Switching on the pump .....	11
	6.3 Pumping condensable vapours .....	11
	6.4 Switching off .....	12
<b>7</b>	<b>Maintenance</b> .....	<b>13</b>
	7.1 Precautions .....	13
	7.2 Cleaning and replacing diaphragms and valves .....	15
	7.3 Checking the pump .....	18
<b>8</b>	<b>Decommissioning</b> .....	<b>18</b>
	8.1 Shutting down for longer periods .....	18
<b>9</b>	<b>Malfunctions</b> .....	<b>18</b>
	9.1 Rectifying malfunctions .....	19
<b>10</b>	<b>Service</b> .....	<b>20</b>
<b>11</b>	<b>Spare parts</b> .....	<b>21</b>
<b>12</b>	<b>Accessories</b> .....	<b>21</b>
<b>13</b>	<b>Technical data and dimensions</b> .....	<b>22</b>
	13.1 General .....	22
	13.2 Technical data .....	23
	13.3 Dimensions .....	23
	13.4 Substances in contact with the media .....	24
	<b>Declaration of conformity</b> .....	<b>25</b>

# 1 About this manual

## 1.1 Validity

This operating manual is for customers of Pfeiffer Vacuum. It describes the functioning of the designated product and provides the most important information for safe use of the unit. The description follows applicable EU guidelines. All information provided in this operating manual refers to the current state of the product's development. The documentation remains valid as long as the customer does not make any changes to the product.

Up-to-date operating instructions can also be downloaded from [www.pfeiffer-vacuum.com](http://www.pfeiffer-vacuum.com).

### Applicable documents

MVP 020-3 AC	Operating instructions
Declaration of Conformity	Part of this document
Operating instructions for accessories (order-specifically)	see section "accessories"

\*also available via [www.pfeiffer-vacuum.com](http://www.pfeiffer-vacuum.com)

For information about other certifications, if applicable, please see the signet on the product or:

- [www.tuvdotcom.com](http://www.tuvdotcom.com)
- TUVdotCOM-ID 0000021320

## 1.2 Conventions

### Safety instructions

The safety instructions in Pfeiffer Vacuum operating instructions are the result of risk evaluations and hazard analyses and are oriented on international certification standards as specified by UL, CSA, ANSI Z-535, SEMI S1, ISO 3864 and DIN 4844. In this document, the following hazard levels and information are considered:

<b>DANGER</b>
<p><b>Imminent danger</b> Indicates an imminent hazardous situation that will result in death or serious injury.</p>
<b>WARNING</b>
<p><b>Possibly imminent danger</b> Indicates an imminent hazardous situation that can result in death or serious injury.</p>
<b>CAUTION</b>
<p><b>Possibly imminent danger</b> Indicates an imminent hazardous situation that can result in minor or moderate injury.</p>
<b>NOTICE</b>
<p><b>Command or note</b> Command to perform an action or information about properties, the disregarding of which may result in damage to the product.</p>

## Pictographs



Prohibition of an action to avoid any risk of accidents, the disregarding of which may result in serious accidents



Warning of a displayed source of danger in connection with operation of the unit or equipment



Command to perform an action or task associated with a source of danger, the disregarding of which may result in serious accidents



Important information about the product or this document

## Instructions in the text

→ Work instruction: here you have to do something.

## Symbols used

The following symbols are used consistently throughout in all illustrations:

- ⓪ Vacuum flange
- Ⓛ Power connection
- Ⓜ Exhaust flange

# 2 Safety

## 2.1 Safety precautions



### Duty to inform

Each person involved in the installation, operation or maintenance of the vacuum pump must read and observe the safety-related parts of these operating instructions.

→ The operator is obligated to make operating personnel aware of dangers originating from the vacuum pump, the pumped medium and the entire system.



### Installation and operation of accessories

Pfeiffer Vacuum pumps can be equipped with a series of adapted accessories. The installation, operation and maintenance of connected devices are described in detail in the operating instructions of the individual components.

→ For information on order numbers of components, see "Accessories".

→ Use original accessory parts only.

- Before pumping dangerous, corrosive or environmentally hazardous media, take suitable precautions:
  - Test the compatibility with substances in contact with the media.
  - Prevent the release of process gases and their reaction products and by-products or dispose of them according to the relevant regulations.
  - Safety measures (e.g. wearing protective clothing and safety goggles) to prevent inhalation and skin contact.
- Connect the vacuum pump to a shockproof socket only.

- Use only undamaged network cables which comply with the regulations.
- Make sure that the grounding is sufficient.
- Do not expose any body parts to the vacuum.
- Observe the safety and accident prevention regulations.
- Check regularly that all safety precautions are being complied with.
- Do not carry out any unauthorised modifications or conversions to the pumps.
- Depending on the operating and ambient conditions, the surface temperature of the pumps may rise above 70 °C. Use suitable finger guards if necessary.
- The unit has been accredited with protection class IP 40. Take necessary measures when installing into ambient conditions, which afford other protection classes.
- When returning the pumps to us please note the instructions in the Service section.

## 2.2 Proper use



### NOTICE

#### EC conformity

The manufacturer's declaration of conformity becomes invalid if the operator modifies the original product or installs additional components.

→ Following installation into a plant and before commissioning, the operator must check the entire system for compliance with the valid EU directives and reassess it accordingly.

- The vacuum pump may only be used to generate a vacuum.
- Installation, operating and maintenance regulations must be complied with.
- Other accessories, than those described in this manual, must not be used without the agreement of Pfeiffer Vacuum.
- When pumping gases which could form explosive or ignitable mixtures, take suitable precautions:
  - If necessary, connect inert gas for ventilation or gas ballast supply.

## 2.3 Improper use

Improper use will cause all claims for liability and warranties to be forfeited. Improper use is defined as usage for purposes deviating from those mentioned above, especially:

- pumping of corrosive or explosive media
- operation in potentially explosive areas
- pumping of gases containing impurities such as particles, dusts and condensate; note the vapour compatibility levels of the pump
- pumping of substances that tend to sublime
- use of the vacuum pump to generate pressure
- pumping of liquids
- connection to pumps or units which are not suitable for this purpose according to their operating instructions
- connection to units which have exposed voltage-carrying parts

## 3 Transport and storage

### 3.1 Transport

- Remove the locking cap from the vacuum and fore-vacuum flange immediately before connecting!
- Use only the handles provided for that purpose to lift the pump.
  - Do not use the interhead connections on the top side of the pump to carry the pump.

### 3.2 Storage

- Check that all the openings on the pump are securely closed.
- Store the pump in a cool, dry place; preferably at room temperatures (approx. 20 °C).
  - For a longer period of storage, seal the pump in a PE bag with drying agents enclosed.

## 4 Product description

### 4.1 Product identification

To correctly identify the product when communicating with Pfeiffer Vacuum, always have the information from the rating plate available.

- Pump model and model number
- Serial number
- Date of manufacture

#### Scope of delivery

- Pump with drive unit
- Operating instructions

## 4.2 Function

The diaphragm vacuum pumps of the series MVP 020-3 AC are dry compressor vacuum pumps with 3 pump stages. The pumps are positive displacement pumps with a periodic change of size of the suction chamber produced by the movement of the diaphragm. The gas flow causes the valves to open and close automatically. The pump units are directly connected to the drive motor.



Fig. 1: MVP 020-3 AC

## 5 Installation

### 5.1 Setting up the pump

#### Installation location

Observe the following requirements when setting up the pump:

- Consider the load-bearing capacity of the installation site.
  - Maximum installation altitude 2000 m (above mean sea level)
  - Permissible ambient temperature: +12 ... 40°C
  - Maximum relative humidity 85%
- Always place the pump on a firm, even surface.
- Where stationary installation is involved, anchor the pump on site.
- When installing the pump in a closed housing, ensure there is sufficient air circulation.
- Voltage and frequency information given on the motor rating plate must be visible.
  - Keep the ventilation openings at the motor free, in order to provide sufficient cooling air.

### 5.2 Connecting the vacuum side

- Remove locking cap on intake connection and connect vacuum pump to the apparatus.
- The connection between the pump and the vacuum chamber should be kept as short as possible.
- Depending on the pump type, use metallic hoses or PVC hoses with flange connections.
  - Separators, filters etc. may be installed upstream to protect the pump (see accessories). However, please observe the loss of pumping capacity due to the conductivity of the accessories.

### 5.3 Connecting the exhaust side



#### CAUTION

##### High pressure in the exhaust line!

Danger of damage to the seals and danger of the pump bursting.

- Install the line without shut-off valves on the exhaust side.
- Do not operate the pump with excess pressure at the inlet; observe the maximum allowable pressures and pressure differences.

- Choose the cross-section of the exhaust line to be at least the size of the nominal connection diameter of the vacuum pump's exhaust connection.
- Piping to the pump must be suspended or supported.
- Physical forces from the piping system must not be allowed to act on vacuum pumps.
- Lay piping from the pump sloping downward so that no condensate can flow back into the pump; otherwise fit a condensate separator.
- If an air trap is created in the system, then a device for draining condensation water must be provided at the lowest point.





### WARNING

#### Emission of toxic substances from the exhaust!

Danger of poisoning from emitted gases or vapours, which can be detrimental to health and/or can pollute the environment, depending on the particular application.

- Comply with the applicable regulations when working with toxic substances.
- Only officially approved filter systems may be used to separate and remove these substances.

## 5.4 Connecting to the mains power supply

The pump is driven by single-phase extended voltage range motors with reversible voltage ranges.



### NOTICE

#### Excess voltage!

Danger of destroying the motor.

- Power connections must comply with local regulations. Voltage and frequency information given on the motor rating plate must correspond to the mains voltage and frequency values.
- To protect the motor and supply cable in case of malfunction, mains fuse protection must be implemented.

### Single phase motors

- The mains voltage must be determined on-site each time before the pump is installed or moved to a different location.



### NOTICE

#### Overvoltage!

An incorrect voltage range setting can damage the motor.

- Always check the set voltage range before switching on the pump.
- Only change the voltage range when the pump is disconnected from the power mains.

#### Changing the voltage range

- Disconnect the pump from the power supply.
- Set the desired voltage range on the voltage selector switch using a suitable screwdriver.

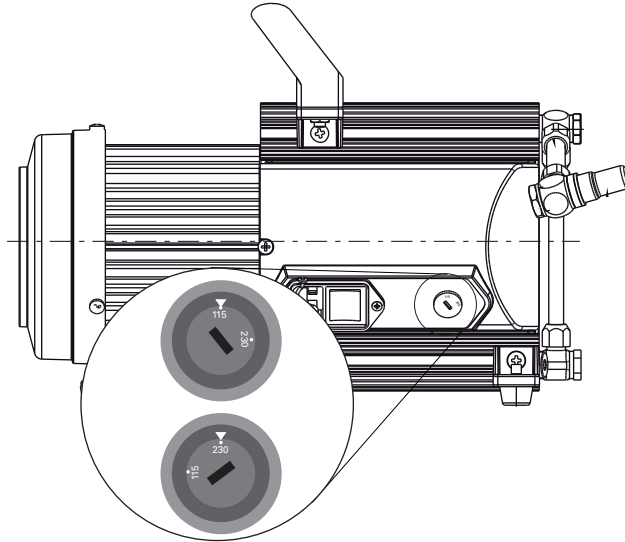

Switch position:	"115/120"	"230/240"
Voltage ranges:	90 ... 126 V, 50/60 Hz	180 ... 254 V, 50/60 Hz

**Motor protection**

A self-locking thermal winding protector switches off the pump motor in the event of over-heating (> 95°C).

→ Allow the pump to cool off several minutes and do not switch it back on until it has cooled off.

**Intermittent operation with TC via relay box (accessory)**

Connection of diaphragm pumps in the pumping station according wiring diagram in operating instructions of the relay box (accessory):

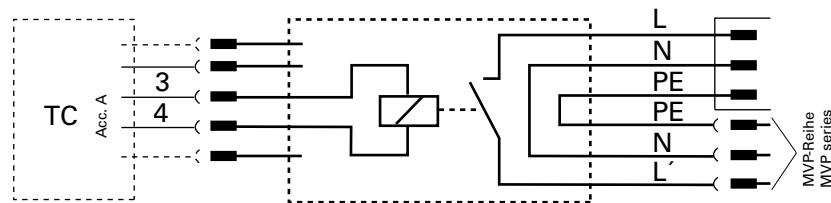

**Fig. 2: Connection of MVP 020-3 AC with relay box to TC 110/400**

## 6 Operation

### 6.1 Before switching on

- Compare the voltage information on the rating plate with the supply voltage.
- Check that the exhaust connection allows free flow (max. permissible pressure 1100 hPa absolute).
  - Activate the shut-off valves in such a way that they open before or at the same time as the pump is started.
- Protect the pump sufficiently from taking in contaminants by means of suitable precautions (e.g. dust filters).



#### CAUTION

##### Dangerous overpressure overload!

Mixing up the connections leads to a dangerous overpressure overload in the pump, and the motor could be damaged.

- Before commissioning, make sure that no impermissibly high pressure arises on the pressure side.
- Start pumps at a maximum pressure differential of 1000 hPa between inlet and outlet.

### 6.2 Switching on the pump

The pump can be switched on in any pressure range between atmospheric and ultimate pressure.

The pump attains the stated values for throughput rates and ultimate pressure levels only once the operating temperature is reached.

- Switch on the pump with the vacuum flange closed and allow to warm up for 15 minutes.



#### CAUTION

##### Hot surface!

Danger of burns if hot parts are touched. Depending on the operating and ambient conditions, the surface temperature of the pump may rise above 70 °C.

- In this case, use suitable finger guards.

#### Intermittent operation with TC via relay box (accessory)

To prolong the life of diaphragm pumps, intermittent operations can be selected with lesser gas throughputs of < 0.18 hPa l/s. This means that, dependent on the TMP power take-up, the backing pump will be switched on and off. TMP power take-up is dependent on the fore-vacuum pressure and gas throughput.

- By comparing the power take-up with an upper and a lower limit value, the relative switch-on duration with lesser gas throughputs can be reduced to approx. 1 to 60%.
- To avoid too frequent switching on, the buffer volume in the fore-vacuum line should amount to  $\geq 0.5$  liter from approx. 0.018 hPa l/s.

**Note!** For this operation mode there is no variable speed control possible.

- Connect galvanic isolated PWM-signal to signal input 16.
  - 0 V ==> Pump „off“
  - 24 V ==> Pump „on“ (max. rotation speed)

### 6.3 Pumping condensable vapours

Steam or moisture from pumped media can condense in the vacuum pump and hence impair the suction performance.



**WARNING**

**Reactive, explosive or otherwise dangerous mixtures!**

Uncontrolled gas inlet at the gas ballast valve can result in dangerous mixtures.

- By implementing the required safety measures, the user must prevent potentially explosive mixtures from occurring in the inside of the pump and from being ignited in the event of a diaphragm crack by mechanically produced sparks, hot surfaces or static electricity.
- If necessary, use inert gas for ventilation and gas ballast supply.



**NOTICE**

**Bad ultimate pressure and damage to the pump!**

Danger of condensation and a reduced ultimate pressure during operation without a gas ballast or in case of insufficient supply of flushing gas.

- Only pump vapors when the pump is warm and the gas ballast valve is open.
- When the process has been completed, allow the pump to continue running for about 30 minutes at atmospheric pressure with the gas ballast open.

**Purge orifice (option)**

The rate of expulsion of condensate can be increased by admitting a purge media (air) and the pump will attain the specified ultimate pressure within a shorter time.

- For this replace the screw plug 20 with a purge orifice 20.1.



**WARNING**

**Danger of process gas discharge!**

For intake pressures > 500 hPa process gas can discharge at the gas ballast valve.

- Use a suction line, if applicable.



**6.4 Switching off**

The pump can be switched off in any pressure range.

## 7 Maintenance

### 7.1 Precautions



#### WARNING

##### **Pump parts may be contaminated from pumped media!**

Danger of poisoning due to contact with harmful substances.

- Decontaminate the pump before carrying out any maintenance work.
- In the event of contamination, take suitable safety precautions to prevent your health from being harmed by any dangerous substances.

The valves and the diaphragms are wear parts. If the rated ultimate vacuum is no longer achieved, the pump interior, the diaphragms and the valves must be cleaned and the diaphragms and valves must be checked for cracks or other damage.

Depending on individual cases it may be efficient to check and clean the pump heads on a regular basis. In case of normal wear the lifetime of the diaphragms and valves is **10000** operating hours at nominal rotation speed.

- Turn off the vacuum pump, vent to atmospheric pressure and allow to cool.
- Only dismantle the pump as far as necessary to carry out maintenance.
- Use only alcohol or similar agents for cleaning pump parts.
- Reassemble pump in reverse order.



#### NOTICE

##### **Service work should be carried out by a qualified person only!**

Pfeiffer Vacuum is not liable for any damage to the pump resulting from work carried out improperly.

- Take advantage of our service training programs; additional information at [www.pfeiffer-vacuum.com](http://www.pfeiffer-vacuum.com).
- Please state all the information on the pump rating plate when ordering spare parts.

**Checklist for inspection, maintenance and overhaul**

Certain maintenance and overhaul work should only be performed by Pfeiffer Vacuum Service (PV). Pfeiffer Vacuum will be released from all warranty and liability claims if the required, below listed, intervals are exceeded or maintenance or overhaul procedures are not performed properly. This also applies if replacement parts other than Pfeiffer Vacuum OEM replacement parts are used.

Activity	daily	as required; at least once every six months	as required; at least after 10000 h	as required; at least every 2 years
Check silencer for contamination		X		
Clean, change valves and diaphragms			X	
Change silencer				X

Depending on the process, the required intervals for inspection and maintenance may be shorter than the guide values specified in the table. Please consult Pfeiffer Vacuum, if necessary.

## 7.2 Cleaning and replacing diaphragms and valves

### Cleaning and replacing the valves

- Turn off the vacuum pump, vent to atmospheric pressure and allow to cool.
- Disconnect the drive motor from the mains and secure it so that it cannot be switched on.
- Unscrew banjo bolt 11 with open-end wrench (SW 14) at housing cover 1.1;
  - loosen connecting hose only at the top.
- Loosen Phillips head screws at handle 9 and slide handle off the guide.
- Unscrew cylinder head screws 1.3 at the pump head and remove housing cover 1.1; be mindful of the position of the valve seals 3.
  - If the valve seals stick to the housing cover, carefully loosen the seals, otherwise remove the valve seals from the head covers.
  - Replace damaged valve seals.
- Remove head cover 3.1.
- Clean all parts and inspect for wear.



### NOTICE

#### Damage to the valves

Valves can be destroyed by gluing to after wrong installation.

- Pay attention to the fitting position of the inlet and outlet valves. The valve flap of the valves may not cover the groove in the head and housing cover.

- Reassemble pump in reverse order.
- Check the other membrane head in the same way.

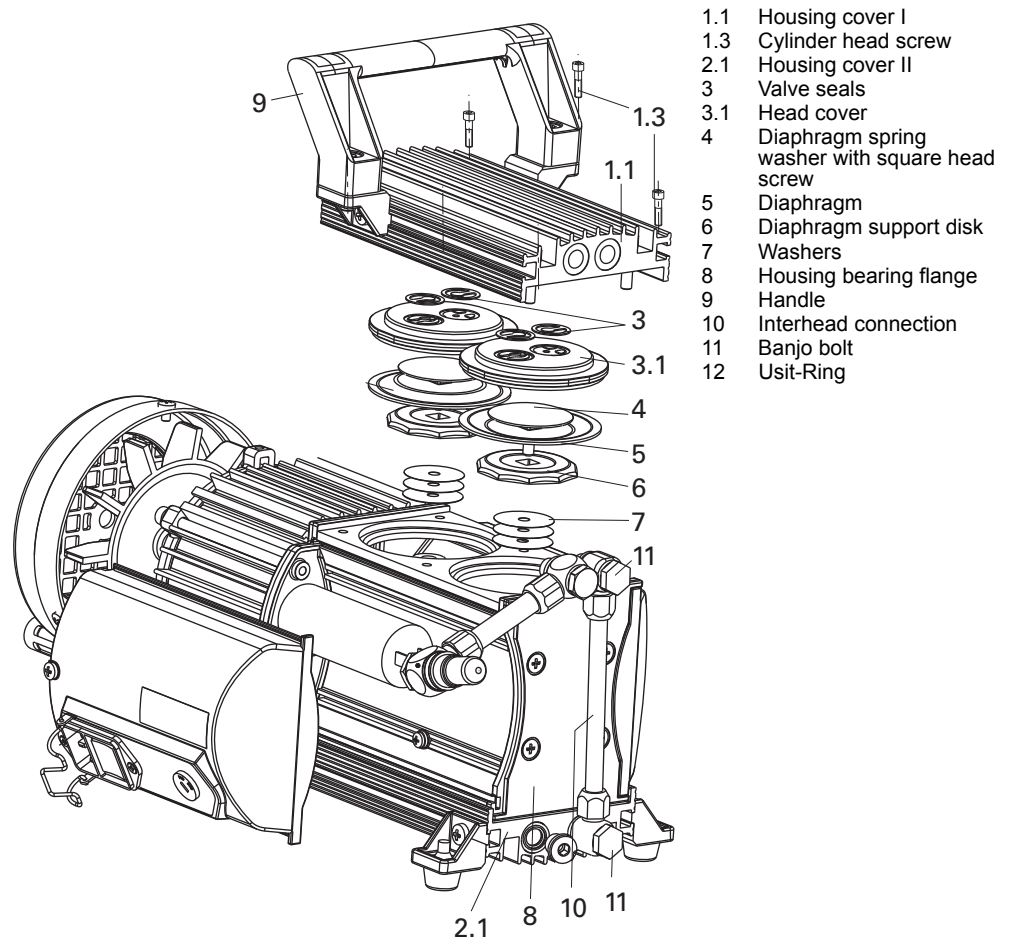
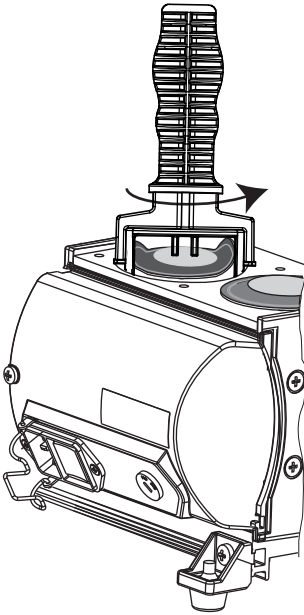

Fig. 3: MVP 020-3 AC

## Changing the diaphragm



Attach the diaphragm key



### NOTICE

#### Damage to the pump and bad ultimate pressure!

A changed dead centre (TDC) leads in the most unfavorable case to a bearing damage.

- Check for spacer disk 7.
- Make sure that the original number is reassembled at the individual membrane head.

- Carry out preliminary work as described before.
- Carefully raise the diaphragm at the side without causing it any damage; do not use sharp-edged tools.
- Slide diaphragm key under the diaphragm until it reaches the support disk.
- Use the diaphragm key to loosen the diaphragm support disk and unscrew together with diaphragm and diaphragm clamping disk.
- Detach diaphragm support disk 6 and diaphragm 5 from the square head of the connecting screw of the diaphragm clamping disk 4.
  - If it is difficult to separate the old diaphragm from the diaphragm support disk 6, loosen in alcohol or cleaning solvent, for example.

## Assembly

- **Assembling** is carried out in reverse order.
- Position new diaphragm 5 between diaphragm clamping disk 4 with square head screw and diaphragm support disk 6; make sure that the square head screw of the diaphragm clamping disk is correctly seated in the guide hole of the diaphragm support disk.



Assemble diaphragms with diaphragm keys

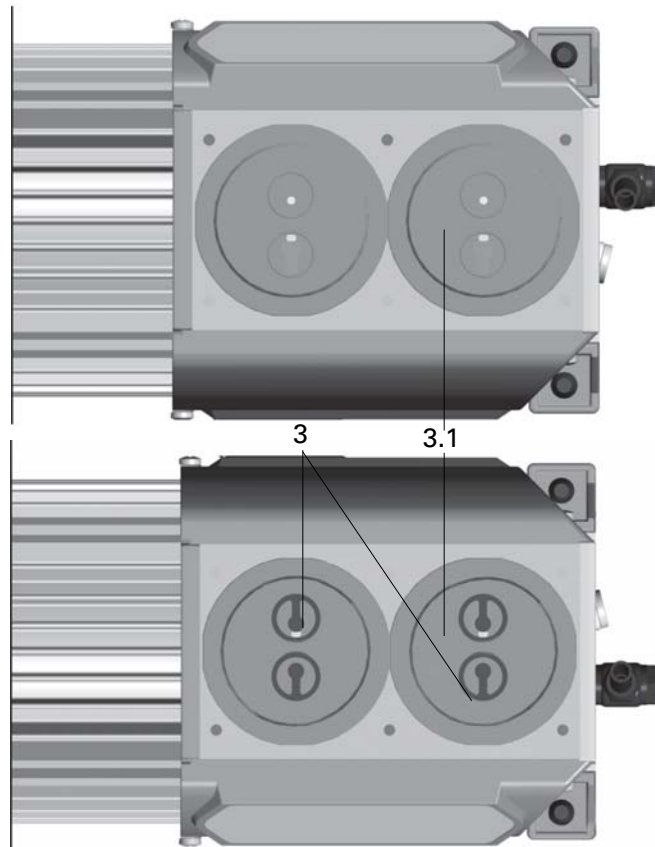
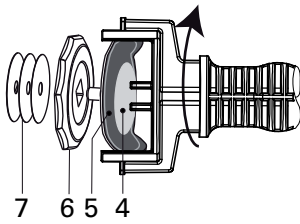

Fig. 4: Position of the valve seal

- Raise the diaphragm at the side and carefully slide the diaphragm key through to the diaphragm support disk.
- When existing, re-fit spacer disks 7 under the diaphragm support disk 6.
- Screw diaphragm clamping disk, diaphragm, diaphragm support disk and spacer disks (if applicable) by hand to connecting rod.
- Bring the diaphragms into a position in which they are in contact with the housing and centred with respect to the bore.
- Refit head cover and valve seals in reverse order, taking care with the position of valve seals (see fig.).
- Mount housing cover 1.1;
  - move housing cover slightly to make sure that the head covers are correctly positioned.
- First gently and then firmly tighten diagonally-offset cheesehead screws 1.3; torque: **6 Nm**.
- Turn pump 180° and similarly disassemble diaphragm head.
- Assemble handle 9 with screws and tighten.
  - Check for correct position of the handle above the centre of gravity of the pump. The handle is in correct position if the end of the handle matches with the end of the housing cover.
- Reassemble connecting hose 10 between the diaphragm heads and screw banjo bolt tightly with open-end wrench (SW 14).

## 7.3 Checking the pump



**The pump doesn't achieve the specified values for throughput and ultimate pressure!**

A run-in period of several hours is required before the pump achieves its specifications.

- Check connecting hoses between pump heads.
- If necessary examine the work performed.

# 8 Decommissioning

## 8.1 Shutting down for longer periods

Before shutting down the pump, observe the following procedure and adequately protect the pump system against corrosion:

**Shortly after condensate has formed:**

- Let the vacuum pump continue to run for several minutes with the intake port open.
- Should media get into the pump which could corrode the pump materials or form deposits, clean and check the diaphragm heads.

**In the long term:**

- Carry out the measures described for brief shutdowns.
- Disconnect the pump from the equipment.
- Close the gas ballast valve, if existing.
- Close the inlet and outlet opening (e.g. with transport caps).
- Store the pump in a dry place.

# 9 Malfunctions

Please note the following instructions should the pump malfunction:



### CAUTION

**Hot surface!**

Danger of burns if hot parts are touched. The surface temperature of the pump may rise above 105 °C in case of malfunction.

- Carry out work on the pump only after it has cooled to a safe temperature.

## 9.1 Rectifying malfunctions

Problem	Possible causes	Remedy
Pump will not start up	Pump temperature too low	Check control voltage
	Thermal protection switch of the motor has responded	Warm up pump to > 12 °C
	Diaphragms or valves dirty	Detect and fix cause of overheating; allow pump to cool off, if necessary
	Overpressure in the exhaust line	Clean pump ( <i>see p. 13, chap. 7</i> )
Pump switches off after a while after being started	Thermal protection switch of the motor has responded	Check exhaust line
	Exhaust pressure too high	Check opening of exhaust line and exhaust accessories
Pump not achieving the ultimate pressure	Condensate in the pump	Operate pump for a longer period of time at atmospheric pressure; open gas ballast valve, if necessary
	Flushing gas nozzle open	Close flushing gas nozzle
	Valves or diaphragms dirty or defective	Clean or change valves and diaphragms ( <i>see p. 13, chap. 7</i> )
	Leak in the system	Repair leak
Pumping speed of pump too low	Intake line not well dimensioned	Keep connections as short as possible and ensure that cross-sections are sufficiently dimensioned
	Exhaust pressure too high	Check opening of exhaust line and exhaust accessories
Unusual noises during operation	Diaphragms or valves defective	Clean or change valves and diaphragms
	Suction chamber dirty	Clean suction chamber
	Silencer loose or missing	Check silencer, replace if necessary
	Valves dirty or defective	Clean or change valves and diaphragms
	Connection rod or motor bearing defective	Contact Pfeiffer Vacuum Service



### NOTICE

#### Service work should be carried out by a qualified person only!

Pfeiffer Vacuum is not liable for any damage to the pump resulting from work carried out improperly.

→ Take advantage of our service training programs; additional information at [www.pfeiffer-vacuum.com](http://www.pfeiffer-vacuum.com).

→ Please state all the information on the pump rating plate when ordering spare parts.

## 10 Service

### **Pfeiffer Vacuum offers first-class service!**

- Maintenance/repairs on the spot by Pfeiffer Vacuum field service
- Maintenance/repairs in the nearby service center or service point
- Fast replacement with exchange products in mint condition
- Advice on the most cost-efficient and quickest solution

Detailed information and addresses at: [www.pfeiffer-vacuum.com](http://www.pfeiffer-vacuum.com) (Service).

### **Maintenance and repairs in the Pfeiffer Vacuum ServiceCenter**

The following steps are necessary to ensure a fast, smooth servicing process:

- ➔ Download the forms "Service Request" and "Declaration on Contamination".<sup>1)</sup>
- ➔ Fill in the "Service Request" form and send it by fax or e-mail to your service address.
- ➔ Include the confirmation on the service request from Pfeiffer Vacuum with your shipment.
- ➔ Fill in the contamination declaration and enclose it in the shipment (required!).
- ➔ Dismantle all accessories.
- ➔ Send the pump in its original packaging if at all possible.

### **Sending of contaminated pumps or devices**

No units will be accepted if they are contaminated with micro-biological, explosive or radioactive substances. "Hazardous substances" are substances and compounds in accordance with the hazardous goods directive (current version). If pumps are contaminated or the declaration on contamination is missing, Pfeiffer Vacuum performs decontamination at the shipper's expense.

- ➔ Neutralise the pump by flushing it with nitrogen or dry air.
- ➔ Close all openings airtight.
- ➔ Seal the pump or unit in suitable protective film.
- ➔ Return the pump/unit only in a suitable and sturdy transport container and send it in while following applicable transport conditions.

### **Service orders**

All service orders are carried out exclusively according to our repair conditions for vacuum units and components.

<sup>1)</sup> Forms under [www.pfeiffer-vacuum.com](http://www.pfeiffer-vacuum.com)

## 11 Spare parts

Pos.	Spare part package/ Spare parts	Pieces MVP 020-3 AC	No.	consisting of the parts
	Set of wearing parts		PU E22 003 -T	4 x Pos. 5, 8 x Pos. 3 Diaphragm key and sealing ring for silencer
2	Silencer	1	P 0995 942	
11	Banjo bolt	1 of 2	P 0995 943	
12	Usit sealing ring	1 of 8	P 3529 133 -P	
	Diaphragm key	1	P 0995 941	

## 12 Accessories

Designation	MVP 020-3 AC
Relay box, shielded, for backing pumps, 1-phase 7A for TC 110/120 and TCP 350, plug M8	PM 071 282 -X
Mains cable 115 / 230 V without plug, right angle IEC 320/C13 socket, 3 m	PK 050 111
Mains cable 230 V with safety plug CEE 7, right angle IEC 320/C13 socket, 2 m	PK 050 109
Mains cable 115 V with NEMA-plug, right angle IEC 320/C13 socket, 2 m	PK 050 110
Flushing gas nozzle for MVP 020-3 / MVP 030-3	PK 050 122
Screw-in flange DN 16 ISO-KF / G 1/8" incl. seal	PK 050 108 -T

Further detailed accessories are contained in the Pfeiffer Vacuum printed or Online Catalogue.

## 13 Technical data and dimensions

### 13.1 General

Conversion table: pressure units

	mbar	bar	Pa	hPa	kPa	Torr mm Hg
mbar	1	$1 \cdot 10^{-3}$	100	1	0.1	0.75
bar	1000	1	$1 \cdot 10^5$	1000	100	750
Pa	0.01	$1 \cdot 10^{-5}$	1	0.01	$1 \cdot 10^{-3}$	$7.5 \cdot 10^{-3}$
hPa	1	$1 \cdot 10^{-3}$	100	1	0.1	0.75
kPa	10	0.01	1000	10	1	7.5
Torr mm Hg	1.33	$1.33 \cdot 10^{-3}$	133.32	1.33	0.133	1

1 Pa = 1 N/m<sup>2</sup>

Conversion table: gas throughput units

	mbar·l/s	Pa·m <sup>3</sup> /s	sccm	Torr·l/s	atm·cm <sup>3</sup> /s
mbar·l/s	1	0.1	59.2	0.75	0.987
Pa·m <sup>3</sup> /s	10	1	592	7.5	9.87
sccm	$1.69 \cdot 10^{-2}$	$1.69 \cdot 10^{-3}$	1	$1.27 \cdot 10^{-2}$	$1.67 \cdot 10^{-2}$
Torr·l/s	1.33	0.133	78.9	1	1.32
atm·cm <sup>3</sup> /s	1.01	0.101	59.8	0.76	1

## 13.2 Technical data

Parameter	MVP 020-3 AC
Flange (in)	G 1/8" elbow union + enclosed hose DN 6 x 1000 mm with an elbow union in G 1/4" at the end
Flange (out)	G 1/8" + silencer
Pumping speed at 50 Hz	1.2 m <sup>3</sup> /h
Pumping speed at 60 Hz	1.4 m <sup>3</sup> /h
Ultimate pressure without gas ballast	≤ 2 hPa
Intake pressure max.	1100 hPa
Exhaust pressure, max.	1100 hPa
Rotation speed at 50 Hz	1500 min <sup>-1</sup>
Rotation speed at 60 Hz	1800 min <sup>-1</sup>
Leak rate	1 · 10 <sup>-2</sup> Pa m <sup>3</sup> /s
Emission sound pressure level without gas ballast	≤ 48 dB (A)
Ambient temperature	12-40 °C
Protection category	IP 40
Mains requirement: voltage 50 Hz	100-115; 200-230 V
Mains requirement: voltage 60 Hz	100-115; 120; 200-230 V
Switch	Yes
Current consumption	1.7 A
Altitude of site, max	2000 m
Weight	6.5 kg
Cooling method, standard	Air

## 13.3 Dimensions

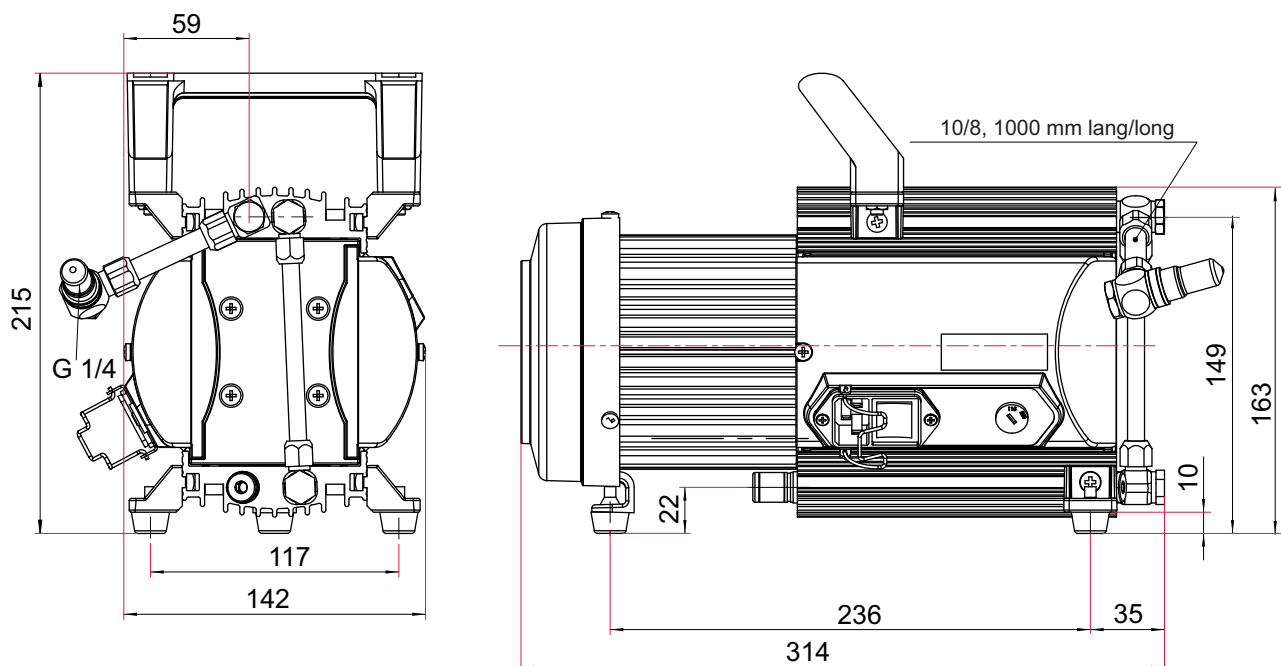

Fig. 5: MVP 020-3 AC (PK T01 110)

## 13.4 Substances in contact with the media

Pump components	Substances in contact with the media
Housing cover	Aluminium
Head cover	Aluminium
Diaphragm clamping disk	Aluminium
Valve seals	FPM
Diaphragm	PTFE coated FPM
Vacuum connection, hose nipple	Aluminium, anodised
Exhaust, silencer	Aluminium and Silicone
Hose	Polyethylene, highly cross-linked
Fittings	Aluminium, anodised





# Declaration of conformity

We hereby declare that the product cited below satisfies all relevant provisions according to the following **EC directives**:

- **Machinery 2006/42/EC (Annex II, no. 1 A)**
- **Electromagnetic Compatibility 2014/30/EU**
- **Restriction of the use of certain Hazardous Substances 2011/65/EU**

The agent responsible for compiling the technical documentation is Mr. Sebastian Oberbeck, Pfeiffer Vacuum GmbH, Berliner Straße 43, 35614 Asslar.

## **MVP 020-3 AC**

Harmonised standards and national standards and specifications which have been applied:

DIN EN ISO 12100 : 2011	DIN EN 61010-1 : 2011	DIN EN 61326-1 : 2013
DIN EN 1012-2 : 2011	IEC 61010-1 : 2010 (Ed. 3)	DIN EN 50581 : 2013

Signature:

Pfeiffer Vacuum GmbH  
Berliner Straße 43  
35614 Asslar  
Germany

---

(Dr. Ulrich von Hülsen)  
Managing Director

2016-07-12

## **VACUUM SOLUTIONS FROM A SINGLE SOURCE**

Pfeiffer Vacuum stands for innovative and custom vacuum solutions worldwide, technological perfection, competent advice and reliable service.

## **COMPLETE RANGE OF PRODUCTS**

From a single component to complex systems:

We are the only supplier of vacuum technology that provides a complete product portfolio.

## **COMPETENCE IN THEORY AND PRACTICE**

Benefit from our know-how and our portfolio of training opportunities!

We support you with your plant layout and provide first-class on-site service worldwide.

Are you looking for a  
perfect vacuum solution?  
Please contact us:

**Pfeiffer Vacuum GmbH**  
Headquarters • Germany  
T +49 6441 802-0  
info@pfeiffer-vacuum.de

[www.pfeiffer-vacuum.com](http://www.pfeiffer-vacuum.com)

**PFEIFFER**  **VACUUM**