



Vacuubrand ME-4CNT+2AK

Technical Specifications

		ME 4C NT +2AK
Number of heads / stages		2 / 1
Max. pumping speed at 50/60 Hz	m ³ /h	3.9 / 4.3
Max. pumping speed at 50/60 Hz	cfm	2.3 / 2.5
Ultimate vacuum (abs.)	mbar/torr	70 / 52
Ambient temperature range (operation)	°C	10 - 40
Ambient temperature range (storage)	°C	-10 - 60
Max. back pressure (abs.)	bar	1.1
Inlet connection		Hose nozzle DN 8-10 mm
Outlet connection		Hose nozzle DN 8-10 mm
Rated motor power	kW	0.18
Rated motor speed at 50/60 Hz	min-1	1500/1800
Protection class		IP 40
Dimensions (L x W x H)	mm	316 x 242 x 291
Weight	kg	13.6
Noise level at 50 Hz, typ.	dBA	45
NRTL certification		Canada and the USA
ATEX conformity (only 230V)		II 3/- G IIC T3 X Internal Atm. only
Items supplied		Pumping unit completely mounted, ready for use, with manual, with dual voltage motor.
Accessories		Upgrade kit manometer with valve (20699906) Rubber vacuum tubing DN 8 mm (20686001) Netzkabel CEE - L-förmige Kaltgerätedose (20637652) Netzkabel CH - L-förmige Kaltgerätedose (20637653) Netzkabel UK - L-förmige Kaltgerätedose (20637654) Netzkabel US - L-förmige Kaltgerätedose (20637655) Netzkabel CN - L-förmige Kaltgerätedose (20635770)



PROVAC

SALES

PHONE: 831-462-8900

FAX: 831-462-3536

WWW.PROVAC.COM

Vacuubrand ME-4CNT+2AK Pumping Curves

50Hz

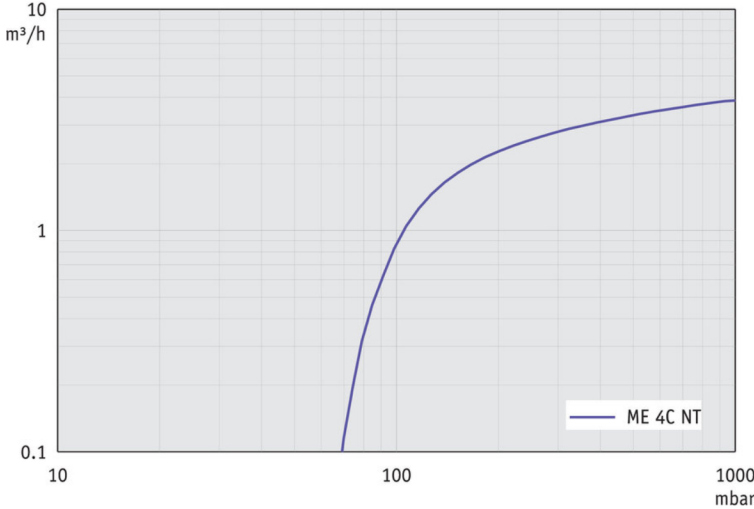

60Hz

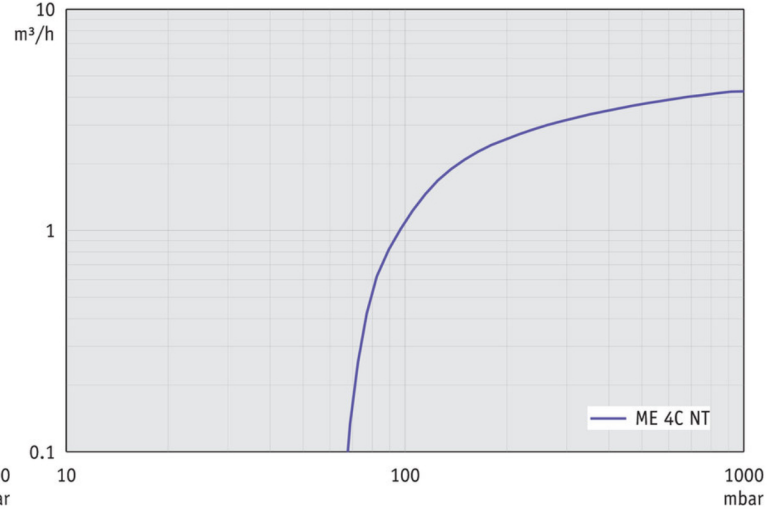

Dimensions

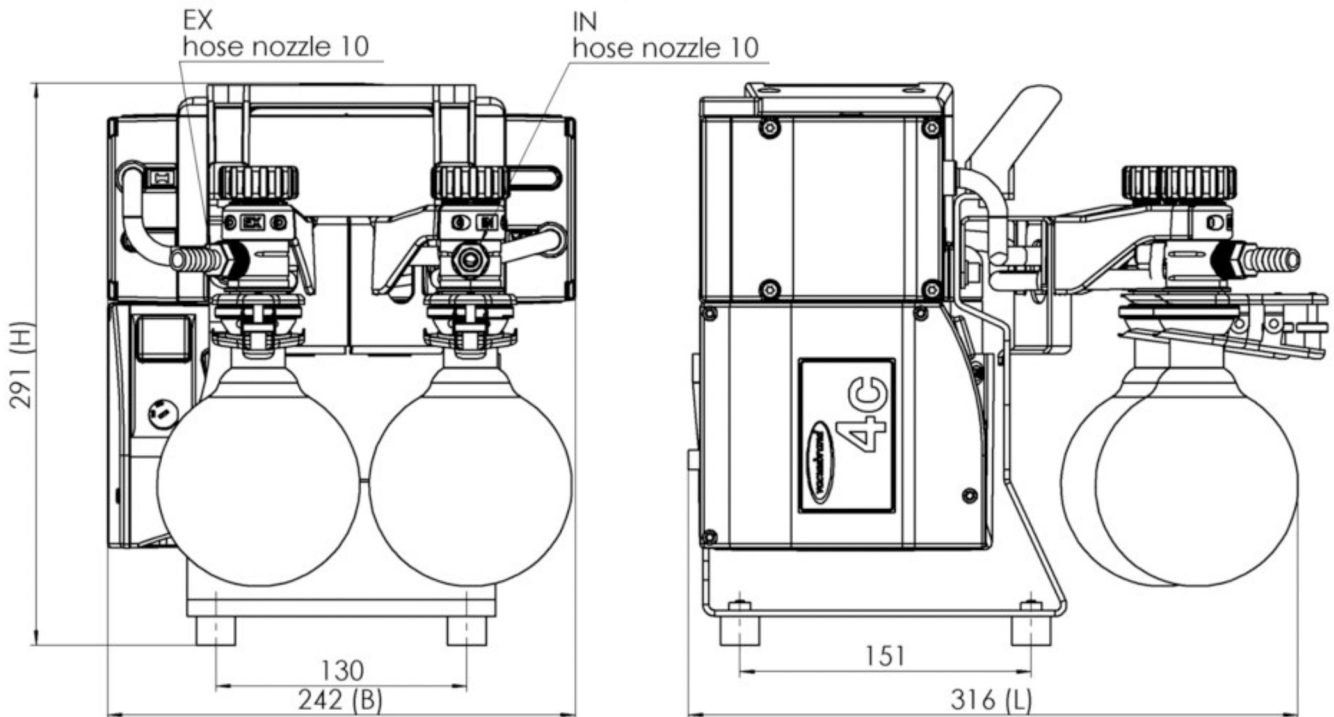

all dimensions (mm)

VACUUBRAND ME 4C NT 2AK
Version 2011/05/11



PROVAC

SALES

PHONE: 831-462-8900

FAX: 831-462-3536

WWW.PROVAC.COM

Vacuubrand ME-4CNT+2AK Features & Benefits

- advantageous combination of high pumping speed & low ultimate vacuum
- ideal for evacuating & pumping large amounts of gases & vapors
- separator at inlet retains particles & liquid droplets
- separator at outlet collects condensate & avoids condensate backflow towards the pump
- whisper quiet & very low vibration
- outstanding chemical resistance & superior vapor tolerance
- compact design

Applications

- drying chambers • filtration & solid phase extraction • local area vacuum networks for laboratories • chemical, biological, & pharmaceutical laboratories • vacuum ovens

