



Technology for Vacuum Systems

CHEMISTRY DIAPHRAGM PUMP

MV 10C VARIO select

MD 12C VARIO select

ME 16C VARIO select

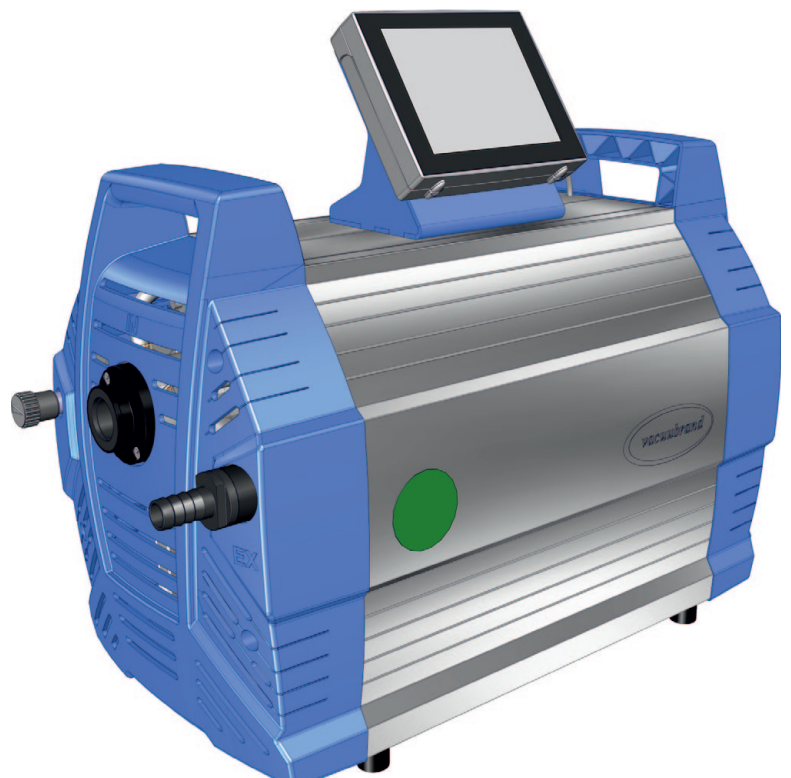

Instructions for use



**Original instructions
Keep for further use!**

This manual is only to be used and distributed in its complete and original form. It is strictly the user's responsibility to carefully check the validity of this manual with respect to the product.

Manufacturer:
VACUUBRAND GMBH + CO KG
Alfred-Zippe-Str. 4
97877 Wertheim
GERMANY

Phone:

- Head office +49 9342 808-0
- Sales +49 9342 808-5550
- Service +49 9342 808-5660

Fax: +49 9342 808-5555
Email: info@vacuubrand.com
Web: www.vacuubrand.com

*Thank you for purchasing this product from **VACUUBRAND GMBH + CO KG**. You have chosen a modern and technically high quality product.*

TABLE OF CONTENTS

| | | |
|----------|---|-----------|
| 1 | Introduction | 5 |
| 1.1 | User information | 5 |
| 1.2 | About this document. | 6 |
| 1.2.1 | Manual structure | 6 |
| 1.2.2 | Display conventions | 7 |
| 1.2.3 | Symbols and icons | 8 |
| 1.2.4 | Handling instructions (action steps). | 9 |
| 1.2.5 | Abbreviations | 9 |
| 1.2.6 | Term definitions. | 10 |
| 2 | Safety information | 11 |
| 2.1 | Usage. | 11 |
| 2.1.1 | Intended use | 11 |
| 2.1.2 | Improper use. | 12 |
| 2.1.3 | Foreseeable misuse. | 12 |
| 2.2 | Obligations | 13 |
| 2.2.1 | Operator obligations | 13 |
| 2.2.2 | Personnel obligations | 13 |
| 2.3 | Target group description. | 14 |
| 2.4 | General safety information | 15 |
| 2.4.1 | Protective clothing. | 15 |
| 2.4.2 | Safety precautions | 15 |
| 2.4.3 | Laboratory and working materials. | 16 |
| 2.4.4 | Eliminate sources of danger | 17 |
| 2.5 | Motor protection | 20 |
| 2.6 | ATEX equipment category | 21 |
| 2.7 | Disposal | 22 |
| 3 | Product description | 23 |
| 3.1 | Schematic design | 23 |
| 3.2 | Chemistry diaphragm pump series. | 24 |
| 3.3 | Example | 25 |
| 4 | Installation and connection | 27 |
| 4.1 | Transport | 27 |
| 4.2 | Installation | 28 |
| 4.3 | Controller base | 30 |
| 4.4 | Connection | 31 |
| 4.4.1 | Vacuum connection (IN) | 31 |
| 4.4.2 | Outlet connection (EX) | 33 |

| | | |
|----------|---|-----------|
| 4.4.3 | Venting connection (option) | 34 |
| 4.4.4 | Gas ballast (GB) | 35 |
| 4.4.5 | Electrical connection | 36 |
| 5 | Commissioning (operation) | 39 |
| 5.1 | Switch on | 39 |
| 5.2 | Operation | 39 |
| 5.2.1 | Operation (→ see <i>description of controller</i>) | 41 |
| 5.2.2 | Operation with gas ballast | 42 |
| 5.3 | Shutdown (switch off) | 43 |
| 5.4 | Storage | 44 |
| 6 | Troubleshooting | 45 |
| 6.1 | Technical support | 45 |
| 6.2 | Error – Cause – Remedy | 45 |
| 7 | Cleaning and maintenance | 49 |
| 7.1 | Information on service work | 50 |
| 7.2 | Cleaning | 52 |
| 7.2.1 | Diaphragm pump | 52 |
| 7.2.2 | Clean or replace molded PTFE hoses | 52 |
| 7.2.3 | Clean or replace the controller | 52 |
| 7.3 | Diaphragm pump maintenance | 53 |
| 7.3.1 | Maintenance items | 53 |
| 7.3.2 | Preparation | 54 |
| 7.3.3 | Suction/pressure distributor maintenance | 56 |
| 7.3.4 | Change the diaphragms and valves | 59 |
| 8 | Appendix | 75 |
| 8.1 | Technical information | 75 |
| 8.1.1 | Technical data | 75 |
| 8.1.2 | Wetted materials | 78 |
| 8.1.3 | Rating plate | 79 |
| 8.2 | Ordering information | 80 |
| 8.3 | Service | 82 |
| 8.4 | Index | 83 |
| 8.5 | EU Declaration of Conformity | 85 |

1 Introduction

This manual is part of your product. The manual applies to all versions of the pump and is intended in particular for laboratory staff.

1.1 User information

Safety

Instructions for use
and safety

- Read this manual thoroughly and completely before using the product.
- Keep this manual in an easily accessible location.
- Correct use of the product is essential for safe operation. Comply with all safety information provided!
- In addition to this manual, adhere to the accident prevention regulations and industrial safety regulations applicable in the country of use.

General

General
information

- For easier readability, the general term *diaphragm pump* is used as an equivalent to and instead of the product name *Mx 1xC VARIO select chemistry diaphragm pump*.
- If passing the product on to a third party, also give them this manual.
- The illustrations in this manual are only intended to facilitate comprehension.
- We reserve the right to make technical changes in the course of continuous product improvement.

Copyright

Copyright © and
copyright law

The content of this manual is protected by copyright. Only copies for internal use are allowed, e. g., for professional training.

© **VACUUBRAND GMBH + CO KG**

Contact

Contact us

- If your manual is incomplete, you can request a replacement. Alternatively, you can use our download portal: www.vacuubrand.com
- You are welcome to contact us at any time in writing or by telephone if you would like more information, have questions about our products or wish to share feedback with us.
- When contacting our Service Department, please have the serial number and product type at hand → see *Rating plate* on the product.

1.2 About this document

1.2.1 Manual structure

Modular instructions for use

The manual has a modular structure with separate instruction modules for the diaphragm pump, vacuum controller, and any accessories.

Instruction modules

Pump series and instructions for use

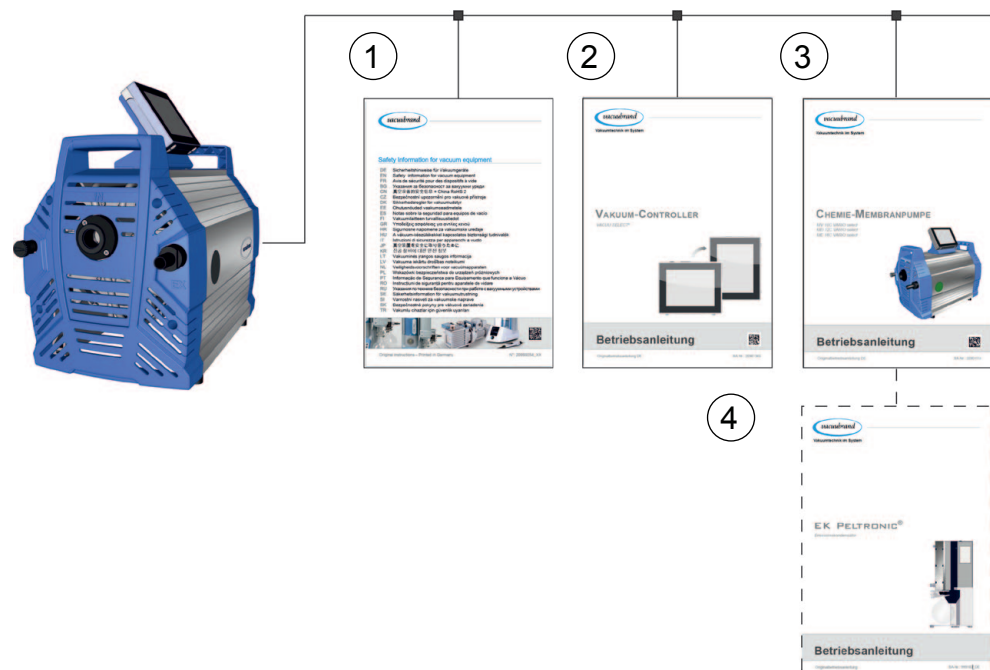

- 1 Safety information for vacuum equipment
- 2 Description: Vacuum controller – control and operation
- 3 Description: Vacuum pump – connection, operation, maintenance, mechanics
- 4 Optional description: Accessories

1.2.2 Display conventions

Warning levels

Display conventions

| | |
|--|---|
| | <p>DANGER</p> <p>Indicates an imminent hazardous situation. Disregarding the situation could result in extremely serious injury or death.</p> <p>⇒ Take appropriate action to avoid dangerous situations!</p> |
| | <p>WARNING</p> <p>Warns of a potentially hazardous situation. Disregarding the situation could result in serious injury or death.</p> <p>⇒ Take appropriate action to avoid dangerous situations!</p> |
| | <p>CAUTION</p> <p>Indicates a potentially hazardous situation. Disregarding the situation could result in minor injury or damage to property.</p> <p>⇒ Take appropriate action to avoid dangerous situations!</p> |
| <p>NOTE</p> <p>Indicates a potentially harmful situation. Disregarding the situation could result in damage to property.</p> | |

Additional notes

IMPORTANT!

- ⇒ Information or specific recommendation which must be observed.
- ⇒ Important information for trouble-free operation of your product.





- ⇒ Helpful tips + tricks
- ⇒ Additional information

1.2.3 Symbols and icons

This manual uses symbols and icons. Safety symbols indicate specific risks associated with handling the product. Symbols and icons are designed to help you identify risks more easily.









Safety symbols

Explanation of safety symbols

| | | | |
|---|--|--|-----------------------------|
|  | Hazardous substance – hazards to human health. |  | General prohibition sign. |
|  | General warning symbol. |  | Warning: risk of explosion. |
|  | Danger: electricity. |  | Warning: hot surface. |
|  | General mandatory sign. |  | Disconnect power plug. |
|  | Wear chemical-resistant protective gloves. |  | Wear protective goggles. |
|  | Read the instructions for repair. | | |

Additional symbols and icons

Additional symbols

| | | | |
|---|--|--|---|
|  | Positive example – Do this! Result – OK |  | Negative example – Don't do this! |
|  | Refers to content in this manual. |  | Refers to content in other supplementary documents. |
|  | Installation at temperatures < 40 °C. |  | Ensure sufficient air circulation. |
|  | Flow arrow Inlet – vacuum connection |  | Flow arrow Outlet – exhaust gas |

1.2.4 Handling instructions (action steps)

Display of operating steps

Instructions (single step)

⇒ Perform the step described.

- Result of action

Instructions (multiple steps)

1. First step

2. Next step

- Result of action

Perform the steps in the order described.

1.2.5 Abbreviations

Abbreviations

| | |
|---|--|
| Fig. | Figure |
| abs. | Absolute |
| ATM | Atmospheric pressure (bar graph, program) |
| d_i (di) | Interior diameter |
| DN | Nominal diameter |
| ECTFE | Ethylene chlorotrifluoroethylene |
| ETFE | Ethylene tetrafluoroethylene |
| EX* | Outlet (exhaust, exit), exhaust gas connection |
|  | ATEX equipment labeling |
| FFKM | Perfluoroelastomer |
| FKM | Fluoroelastomer |
| GB | Gas ballast |
| IN* | Inlet, vacuum connection |
| KF | Small flange |
| max. | Maximum value |
| min. | Minimum value |
| PP | Polypropylene |
| PPS | Polyphenylene sulfide |
| PTFE | Polytetrafluoroethylene |
| RMA no. | Return Merchandise Authorization number |
| SW | Wrench size (tool) |
| resp. | Responsible |
| e. g. | For example |

* Labeling on the vacuum pump or component

1.2.6 Term definitions

Product-specific
terms

| | |
|---------------------------------|---|
| Mx 1xC VARIO select | Vacuum pump with variable speed motor for precise vacuum control, including VACUU-SELECT® controller and VACUU-SELECT® Sensor . |
| VACUU-BUS® | Bus system from VACUUBRAND for communication between peripheral devices with VACUU-BUS® -enabled gauges and controllers. The maximum admissible cable length is 30 m. |
| VACUU-BUS® address | Address which enables the VACUU-BUS® client to be unambiguously assigned within the bus system, e. g., for connecting multiple sensors with the same measuring range. |
| VACUU-BUS® client | Peripheral device or component with VACUU-BUS® port which is integrated in the bus system, e. g., sensors, valves, level indicators, etc. |
| VACUU-BUS® connector | 4-pin round connector for the bus system from VACUUBRAND . |
| VACUU-BUS® configuration | Assigning a different VACUU-BUS® address to a VACUU-BUS® component using a gauge or controller. |
| VACUU-LAN® | Local area vacuum network. |
| VACUU-SELECT® | Vacuum controller, controller with touchscreen; consisting of operating panel and vacuum sensor. |
| VACUU-SELECT® Sensor | External vacuum sensor ▶ for VACUU-SELECT® <i>or</i> ▶ separately as an independent vacuum sensor. |
| VARIO® drive | Speed control for vacuum pump; the motor runs only as fast as necessary to meet demand. |

2 Safety information

The information in this chapter must be observed by everyone who works with the product described here.

The safety information is valid for the entire life cycle of the product.

2.1 Usage

Only use the product if it is in perfect working condition.

2.1.1 Intended use

Intended use

A chemistry diaphragm pump from the *Mx 1xC VARIO select* product series is a vacuum system consisting of a variable speed vacuum pump, controller, and sensor, for the creation and control of rough vacuum in designated systems, e. g., evacuating distillation equipment, as a vacuum dryer or in systems with VACUU-LAN local area vacuum network etc.

The vacuum system may only be used indoors in a non-explosive atmosphere.

Intended use also includes:



- observing the information in the document **Safety information for vacuum equipment**,
- observing the manual,
- observing the manual of connected components,
- observing the inspection and maintenance intervals and having maintenance performed by appropriately qualified personnel.
- using only approved accessories or spare parts.

Any other use is considered improper use.

2.1.2 Improper use

Improper use Incorrect use or any application which does not correspond to the technical data may result in injury or damage to property.

Improper use includes:

- using the product contrary to its intended use,
- using the product in non-commercial environments, unless the necessary protective measures and precautions have been taken by the company,
- operation under inadmissible environmental and operating conditions,
- operation despite obvious faults or defective safety devices,
- unauthorized extensions or conversions, in particular when these impair safety,
- usage despite incomplete assembly,
- operation with sharp-edged objects,
- pulling plug-in connections on the cable out of the socket,
- aspirating, conveying, or compressing solids or fluids.

2.1.3 Foreseeable misuse

Foreseeable misuse In addition to improper use, there are types of use which are prohibited when handling the pump:

Prohibited types of use include, in particular:



- use on humans or animals,
- installation and operation in potentially explosive atmospheres,
- use in mines or underground,
- using the product to generate pressure,
- fully exposing vacuum equipment to the vacuum,
- immersing vacuum equipment in liquids, or exposing it to water spray or steam jets,

Foreseeable misuse

- pumping oxidizing and pyrophoric substances, liquids or solids,
- pumping hot, unstable, or explosive media,
- pumping substances which may react explosively under impact and/or elevated temperature without an air supply.

IMPORTANT!

No foreign bodies, hot gases or flames from the application must be allowed to enter the equipment.

2.2 Obligations

2.2.1 Operator obligations

Operator obligations

The owner defines the responsibilities and ensures that only trained personnel or specialists work on the vacuum system. This applies in particular to connection, assembly and maintenance work, and troubleshooting.

Users in the areas of competence in the *Responsibility matrix* must possess the relevant qualifications for the activities listed. In particular work on electrical equipment must be performed only by qualified electricians.

2.2.2 Personnel obligations

Personnel obligations

In the case of activities which require protective clothing, personal protective equipment as specified by the operator is to be worn.

If the vacuum system is not in proper working order, it must be prevented from being accidentally switched back on.

- ⇒ Always be conscious of safety and work in a safe manner.
- ⇒ Observe instructions issued by the operator, and national regulations on accident prevention and industrial safety.



The way individuals act can help to prevent accidents at work.

2.3 Target group description

Target groups The manual must be read and observed by every person who is tasked with the activities described below.

Personnel qualification

| | | |
|---------------------------|-------------------------------|--|
| Qualification description | Operator | Laboratory staff, such as chemists, laboratory technicians |
| | Specialist | Person with professional qualification in mechanics, electrical equipment or laboratory devices |
| | Responsible specialist | Similar to a specialist, with additional specialist responsibility, or responsibility for a department or division |

Responsibility matrix

Responsibility matrix

| Activity | Operator | Specialist | Responsible specialist |
|------------------------------|----------|------------|------------------------|
| Installation | x | x | x |
| Commissioning | x | x | x |
| Network integration | | | x |
| Operation | x | x | x |
| Error report | x | x | x |
| Remedy | (x) | x | x |
| Maintenance | | x | x |
| Repair ¹ | | x | x |
| Repair order | | | x |
| Cleaning, simple | x | x | x |
| Shutdown | x | x | x |
| Decontamination ² | | x | x |

1 See also our website:

VACUUBRAND > Support > [Instructions for repair](#)

2 Alternatively, arrange for decontamination by a qualified service provider

2.4 General safety information

Quality standards and safety

Products from **VACUUBRAND GMBH + CO KG** are subject to stringent quality testing with regard to safety and operation. Each product undergoes a comprehensive test program prior to delivery.

2.4.1 Protective clothing

Protective clothing

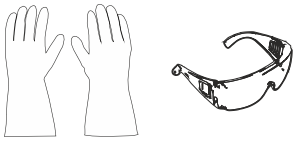

No special protective clothing is required to operate the vacuum pump. Observe instructions issued by the operator for your workplace.

During cleaning, maintenance and repair work, we recommend wearing chemical-resistant protective gloves, protective clothing and protective goggles.

IMPORTANT!

⇒ When handling chemicals, wear your personal protective equipment.

2.4.2 Safety precautions

Safety precautions

- ⇒ Use your vacuum equipment only if you have understood its function and this manual.
- ⇒ Replace defective parts immediately, e. g., a broken power cable, faulty hoses or faulty flasks.
- ⇒ Use only original accessories and components which are designed for the vacuum technology, such as a vacuum hose, separator, vacuum valve, etc.
- ⇒ When handling contaminated parts, follow the relevant regulations and protective measures; this also applies to equipment sent in for repair.

IMPORTANT!

Prior to returning any product to our Service Department for repair, contamination from hazardous substances needs to be excluded.

⇒ Fill out the [Health and Safety Clearance form](#) in full and confirm with your signature.

2.4.3 Laboratory and working materials

| | |
|---|--|
|  | DANGER |
| | <p>Hazardous substances could be discharged at the outlet.</p> <p>During aspiration, hazardous, toxic substances at the outlet can get into the ambient air.</p> <ul style="list-style-type: none"> ⇒ Observe the relevant safety regulations for safe handling of hazardous substances. ⇒ Please note that residual process media may pose a danger to people and the environment. ⇒ Mount and use suitable separators, filters or fume hood devices. |

Hazards due to different substances

Pumping different substances

Pumping different substances or media can cause the substances to react with one another.

Working materials which get into the vacuum pump with the gas flow can damage the vacuum pump. Hazardous substances can be deposited in the vacuum pump.

Possible protective measures, depending on the application:

- ⇒ Purge the vacuum pump with inert gas or air before changing the medium to be pumped.
- ⇒ Use inert gas to dilute critical mixtures.
- ⇒ Prevent the release of hazardous, toxic, explosive, corrosive fluids, gases or vapors or those that are harmful to health or the environment, for example, through suitable laboratory facilities with a fume hood and ventilation control.
- ⇒ Protect the inside of the vacuum pump from deposits or moisture, e. g, through the provision of a gas ballast.
- ⇒ Be aware of interactions and possible chemical reactions of the pumped media.
- ⇒ Check the compatibility of the pumped substances with the wetted materials of the vacuum pump.
- ⇒ Contact us if you have concerns about using your vacuum pump with certain working materials or media.

2.4.4 Eliminate sources of danger

Take mechanical stability into account

Note
mechanical load
capacity

The high compression ratio of the pump may result in a higher pressure at the outlet than the mechanical stability of the system allows.

- ⇒ Always ensure that the outlet line is clear and non-pressurized. The outlet must not be blocked to ensure that gases can exit freely.
- ⇒ Prevent uncontrolled overpressure, e. g, due to a locked or blocked piping system, condensate or clogged outlet line.
- ⇒ At the gas connections, the connections for the inlet **IN** and outlet **EX** must not be mixed up.
- ⇒ Be aware of the max. pressures at the inlet and outlet of the pump as well as the max. admissible differential pressure between the inlet and outlet, according to **8.1.1 Technical data on page 75**.
- ⇒ The system to be evacuated as well as all hose connections must be mechanically stable.

Prevent condensate return

Prevent backup in
the outlet line

Condensate can damage the pump head. Condensate must not flow back into the outlet **EX** or pump head through the hose line. Liquid must not accumulate inside the exhaust gas hose.

- ⇒ Avoid condensate return by using a separator (accessory). Condensate must not enter the inside of the housing via the hose lines.
- ⇒ Preferably route the exhaust gas hose with a fall from the outlet, i.e., running downward so that no backup forms.

Prevent incorrect measurements Incorrect measurements due to a blocked vacuum line, e. g., condensate in the vacuum line, can distort the measurements taken by the vacuum sensor.

⇒ Prevent overpressure > 1060 mbar (795 Torr) inside the suction line.

Prevent foreign bodies inside the pump

Observe vacuum pump design Particles, liquids and dust must not get inside the vacuum pump.

⇒ Do not pump any substances which could form deposits inside the vacuum pump.

⇒ Install suitable separators and/or filters upstream of the inlet. Suitable filters are chemically resistant, clog-proof and have a reliable flow rate, for example.

⇒ Replace porous vacuum hoses without delay.

Hazards during venting

Hazards when venting Depending on the application, explosive mixtures can form or other hazardous situations can arise in systems.

Hazards due to residual energy

Possible residual energy After the vacuum pump has been switched off and disconnected from the power supply, there may still be dangers due to residual energy:

- Thermal energy: Motor waste heat, hot surfaces, compression heat.

⇒ Allow the vacuum pump to cool down.

- Electrical energy: The capacitors on the electronic assembly have a discharge time of up to 3 minutes.

⇒ Wait until the capacitors have discharged.

Risk of burns due to hot surfaces or overheating

Surface temperatures

The surface of the vacuum pump can reach operating temperatures > **70 °C**, in particular when pumping heated media.

- ⇒ Avoid direct contact with the surface.
- ⇒ Use protection against accidental contact if the surface temperature is regularly elevated.
- ⇒ Allow the vacuum pump to cool down before performing maintenance work.

Overheating

The vacuum pump can be damaged due to overheating. Possible causes include insufficient air supply to the fan and failure to maintain minimum distances.

- ⇒ When installing the device, ensure that there is a minimum distance of 5 cm between the fan and adjacent parts (such as the housing, walls, etc.).
- ⇒ Always ensure a sufficient air supply; if applicable, provide external forced ventilation.
- ⇒ Place the device on a stable surface; a soft surface such as foam rubber as a sound absorber can impair and block the air supply.
- ⇒ Clean polluted ventilation slots.
- ⇒ Remove covers from the device before operating it.
- ⇒ Avoid excessive heat input due to hot process gases.
- ⇒ Observe the maximum admissible media temperature
→ see *chapter: 8.1.1 Technical data on page 75*.

Keep signs legible

- Labels and signs Keep any signs affixed to the device in an easily readable condition:
- ⇒ Connection labels
 - ⇒ Warning and information signs
 - ⇒ Motor data and rating plates

2.5 Motor protection

Overheating protection, blockage protection The pump motor has a temperature sensor on the circuit board as overload protection. In the event of excessive temperature or if the motor is blocked, the vacuum pump switches off.

Procedure for switching vacuum pump back on If the vacuum pump is switched off due to these safety precautions, the error must be cleared manually: Unplug vacuum pump from power supply -> eliminate cause of error -> switch vacuum pump back on.

2.6 ATEX equipment category

Installation and potentially explosive atmospheres



The installation and operation in areas where potentially explosive atmospheres can develop to a hazardous degree is not permitted.

ATEX approval only applies to the internal, wetted parts of the of the device, not to its surroundings.

ATEX equipment labeling

ATEX equipment category



Vacuum equipment labeled with ϵx has ATEX approval in line with the ATEX marking on the rating plate.

- ⇒ Only use the product if it is in perfect working condition.
- ⇒ The devices are designed for a low level of mechanical stress and must be installed in such a way that they cannot sustain mechanical damage from the outside.

ATEX equipment category and peripheral devices

The ATEX equipment category of the product is dependent on the connected components and peripheral devices. Components and peripheral devices need to have the same or higher ATEX approval.

Prevent ignition sources

The use of venting valves is only permitted if this would not normally, or only rarely, cause explosive mixtures within the device, or do so only for a short time.

- ⇒ If necessary vent with inert gas.

Information on the ATEX equipment category is also available on our website at: www.vacuubrand.com/.../Information-ATEX

2.7 Disposal



NOTE

Risk of environmental damage due to incorrect disposal of the product.

- ⇒ Do not dispose of the product with household waste! Electronic components are subject to hazardous waste treatment and must only be disposed of by certified specialists.
- ⇒ Observe the national regulations for safe disposal and environmental protection.
- ⇒ Detailed information on the respective regulations can be obtained from your local administrative authority.

3 Product description

The chemistry diaphragm pumps described essentially consist of a diaphragm pump with VARIO® drive, a **VACUU-SELECT®** vacuum controller, and a **VACUU-SELECT®** Sensor.

3.1 Schematic design

Side and front view

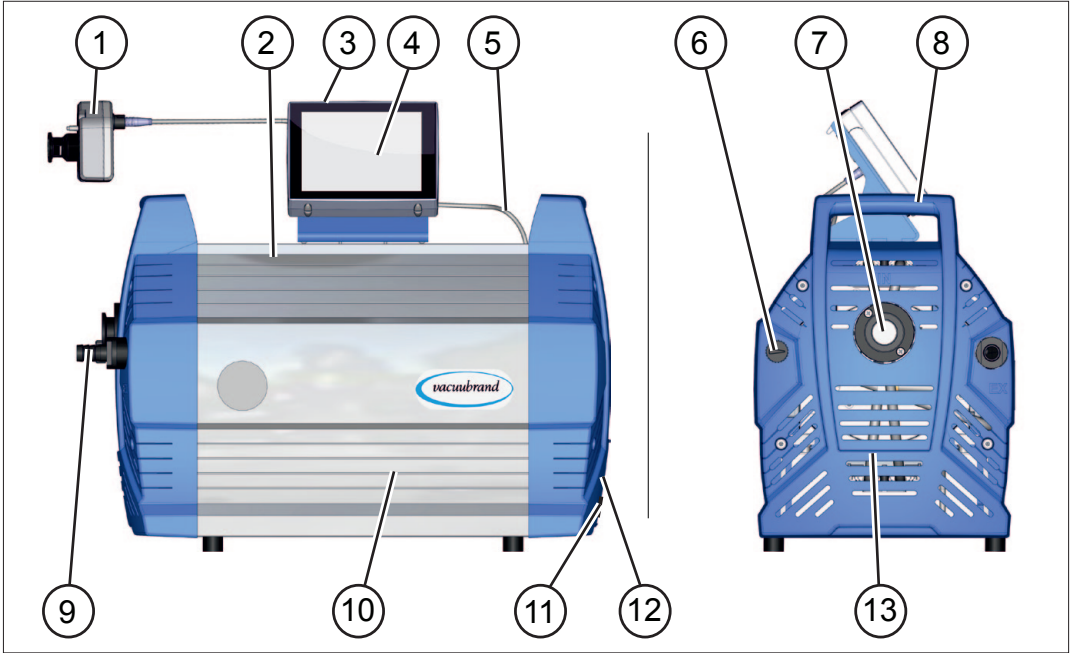

Meaning

| | |
|----|---|
| 1 | VACUU-SELECT® Sensor, to be mounted externally on suction line |
| 2 | Chemistry diaphragm pump |
| 3 | Vacuum controller ON/OFF button |
| 4 | VACUU-SELECT® operating panel |
| 5 | VACUU-SELECT® VACUU-BUS cable (power supply + control cable) |
| 6 | Gas ballast valve |
| 7 | Vacuum connection – inlet IN |
| 8 | Handles (2x) |
| 9 | Outlet connection – outlet EX |
| 10 | Side panel, cover |
| 11 | Power connection, ON/OFF button (rocker switch) |
| 12 | Rating plate |
| 13 | Housing section with handle, front |

3.2 Chemistry diaphragm pump series

Overview of chemistry diaphragm pumps

Mx 1xC VARIO
select chemistry
diaphragm pumps

| Chemistry diaphragm pump | Pump heads | Stages |
|--------------------------|------------|--------|
| ME 16C VARIO select | 8 | 1 |
| MD 12C VARIO select | 8 | 3 |
| MV 10C VARIO select | 8 | 4 |

3.3 Example

Local area vacuum network

→ Example
Local area vacuum
network

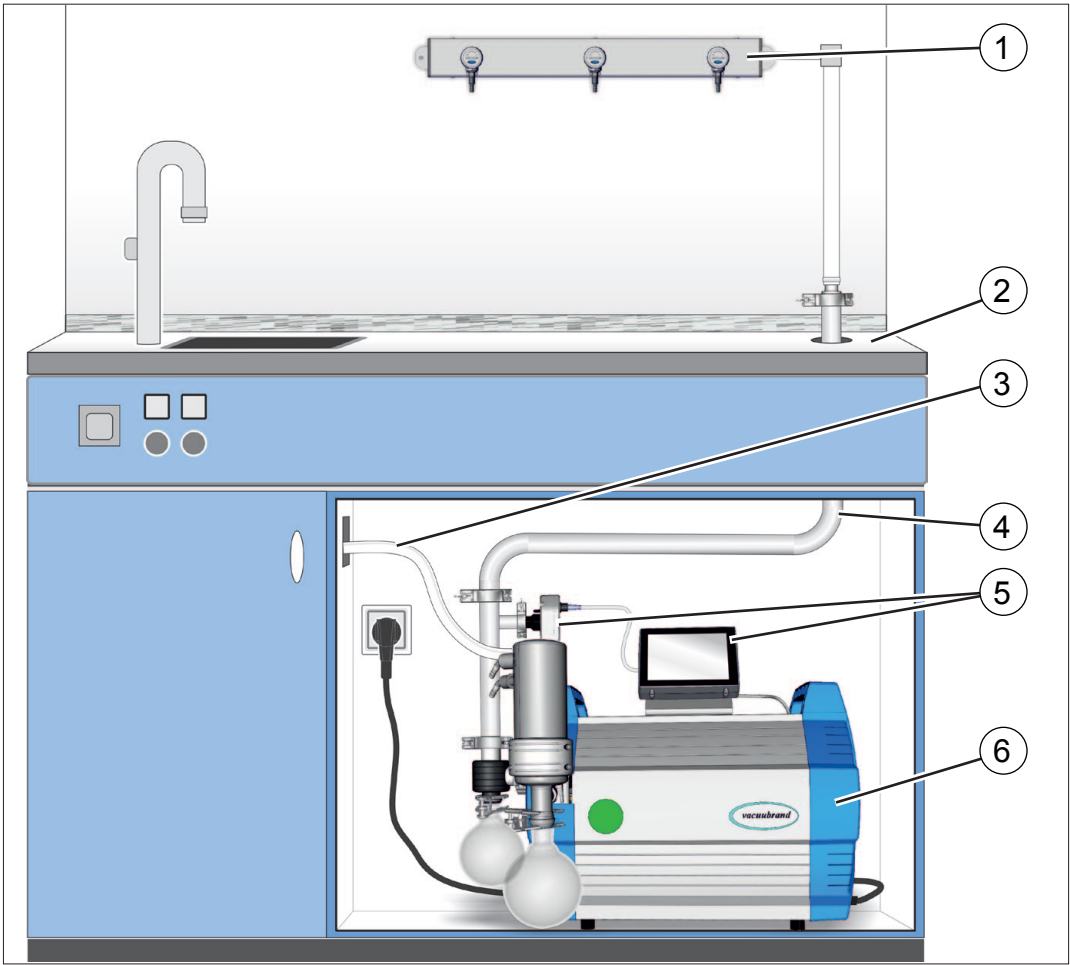

Meaning

- 1 Example: VACUU-LAN®, local area vacuum network with three valve modules
- 2 Lab furniture
- 3 Outlet hose (diverted into a fume hood)
- 4 Vacuum tubing
- 5 **VACUU-SELECT** operating panel + **VACUU-SELECT** Sensor
- 6 MD 12C VARIO select diaphragm pump (with accessories: separator at inlet and vapor condenser at outlet)

4 Installation and connection

4.1 Transport

Products from **VACUUBRAND** are packed in sturdy, recyclable packaging.



The original packaging is accurately matched to your product for safe transport.

⇒ If possible, please keep the original packaging, e. g., for returning the product for repair.

Goods receipt

Check the shipment for transport damage and completeness.

⇒ Immediately report any transport damage in writing to the supplier.

Unpacking

→ Example
Diaphragm pump in
original packaging
with enclosed
packages

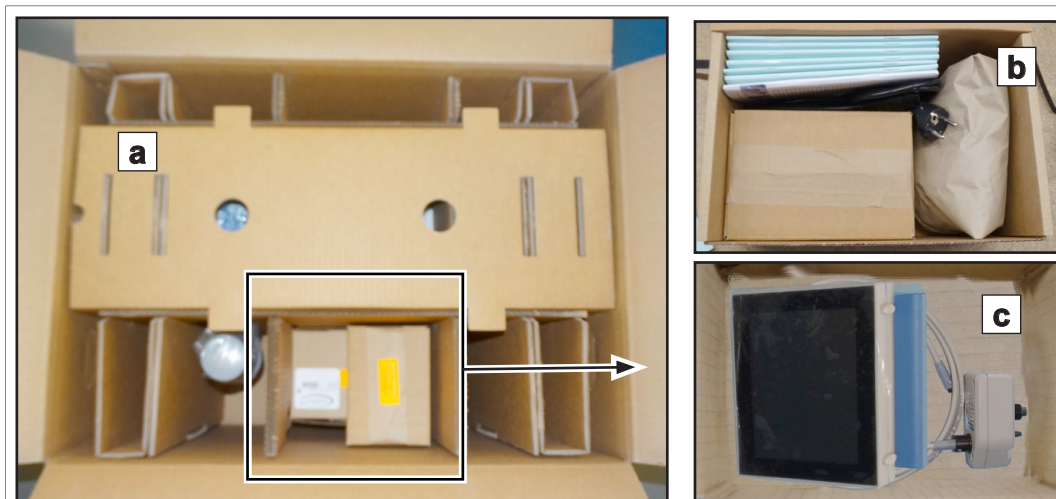

(a) = diaphragm pump (shown here with vapor condenser accessory)

(b) = manual, cable, and any accessories

(c) = controller, vacuum sensor, cable

⇒ Remove all enclosed packages from their original packaging and unpack them.

⇒ Compare the scope of delivery with the delivery note.

→ Example
Lift out the diaphragm pump (shown with vapor condenser accessory)



- ⇒ Please note that a **diaphragm pump can weigh approx. 25 kg**. We recommend using a lifting aid.
- ⇒ Lift the unit out of the packaging by the side handles.

4.2 Installation

NOTE

Condensate can damage the electronics.

A large temperature difference between the storage location and the installation location can cause condensation.

- ⇒ After goods receipt or storage, allow your vacuum device to acclimatize for at least 3-4 hours before initial use.

Check installation conditions

Check installation conditions

- The device is acclimatized.
- Ambient conditions have been observed and are within the limitation of use.
- The pump must have a stable and secure base without additional mechanical contact apart from the pump feet.

Installing the vacuum pump

⇒ Place the vacuum pump on a stable, non-vibrating, level surface.

→ Example Sketch of minimum distances in lab furniture

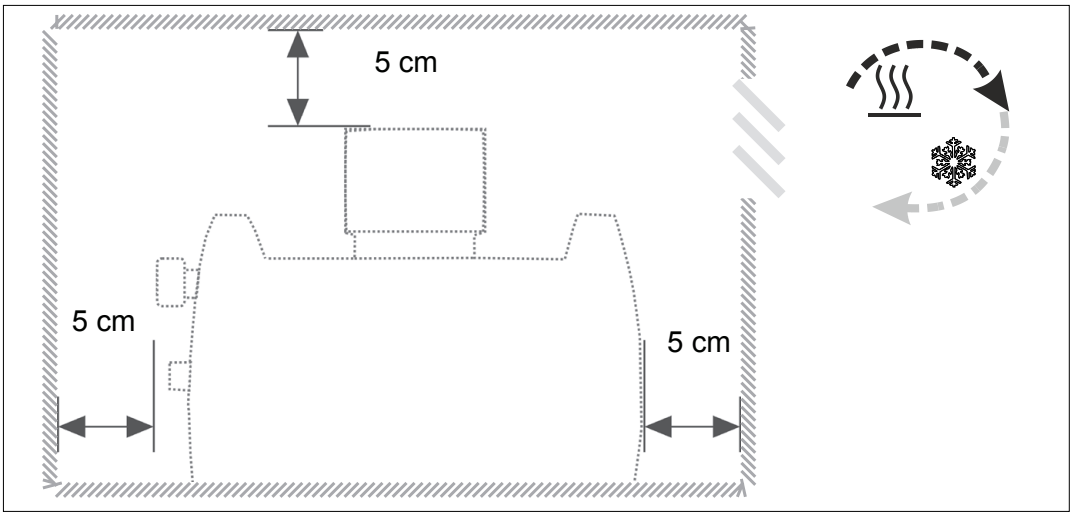

IMPORTANT!

⇒ When installing in lab furniture, maintain a minimum distance of 5 cm (2 in.) to adjacent objects or surfaces.

⇒ Prevent heat accumulation and ensure sufficient air circulation, especially in closed housings.

Observe limitation of use

Observe limitation of use

| Limitation of use | | (US) |
|---|---------------------------|----------------------------|
| Ambient temperature | 10–40 °C | 50-104 °F |
| Max. altitude | 2000 m above sea level | 6562 ft above sea level |
| Minimum distance to adjacent parts | 5 cm | 2 in |
| Relative humidity | 30-85 %, non-condensing | |
| Protection class | IP 40/IK 08 | |
| Prevent condensation or contamination from dust, liquids, or corrosive gases. | | |

IMPORTANT!

⇒ Note the IP protection class. IP protection is only guaranteed if the device is appropriately mounted and connected.

⇒ For connection also note the rating plate data and chapter **8.1.1 Technical data on page 75.**

4.3 Controller base

The base, controller, screw fittings and vacuum sensor are enclosed separately. Before installation, the base can be mounted on the pump and the controller clipped into place.

Alternatively, the controller can be clipped into a recess in the lab furniture or used as a freestanding unit (unfold the stand).

Mount the base

Mount the base to the diaphragm pump (option)

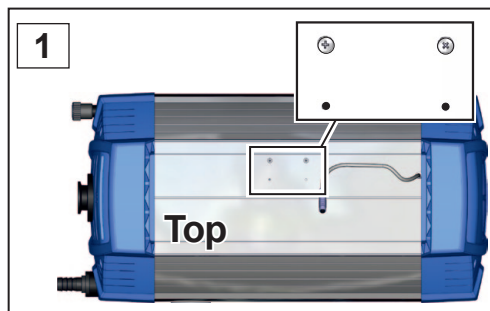

1. Unscrew the screws; Phillips screwdriver size 1.



2. Position the base on the diaphragm pump.

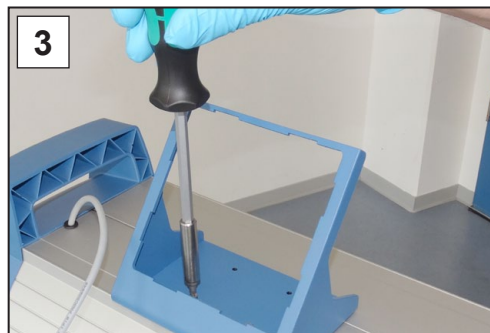

3. Screw the base onto the diaphragm pump.



4. Clip the controller into the base.



5. Plug the VACUU·BUS cable into the power connection on the back of the controller.



6. Also plug in the VACUU·BUS cables from peripheral devices. Use Y adapters (accessories) if there are not enough connections.

4.4 Connection

The diaphragm pumps have a vacuum connection and an outlet connection. Connect your diaphragm pump as described in the examples below.

4.4.1 Vacuum connection (IN)



CAUTION

Flexible vacuum hoses can contract during evacuation.

Connected components that are not secured can cause injury or damage due to jerky movement (shrinkage) of the flexible vacuum hose. The vacuum hose can come loose.

- ⇒ Secure the vacuum hose to the connections.
- ⇒ Secure connected components.
- ⇒ Take the maximum shrinkage into account when sizing the flexible vacuum hose.

NOTE

Foreign bodies in the suction line can damage the vacuum pump.

- ⇒ Prevent particles, liquids or contaminants from being aspirated or being able to flow back.

IMPORTANT!

- ⇒ Use a sufficiently stable vacuum hose that is designed for the required vacuum range.
- ⇒ Keep hose lines as short as possible.
- ⇒ The connection between hose lines and the vacuum pump must be gas-tight.
- ⇒ Avoid kinks in the vacuum hose.

Connect the vacuum hose

→ Example
Vacuum connection
at the inlet

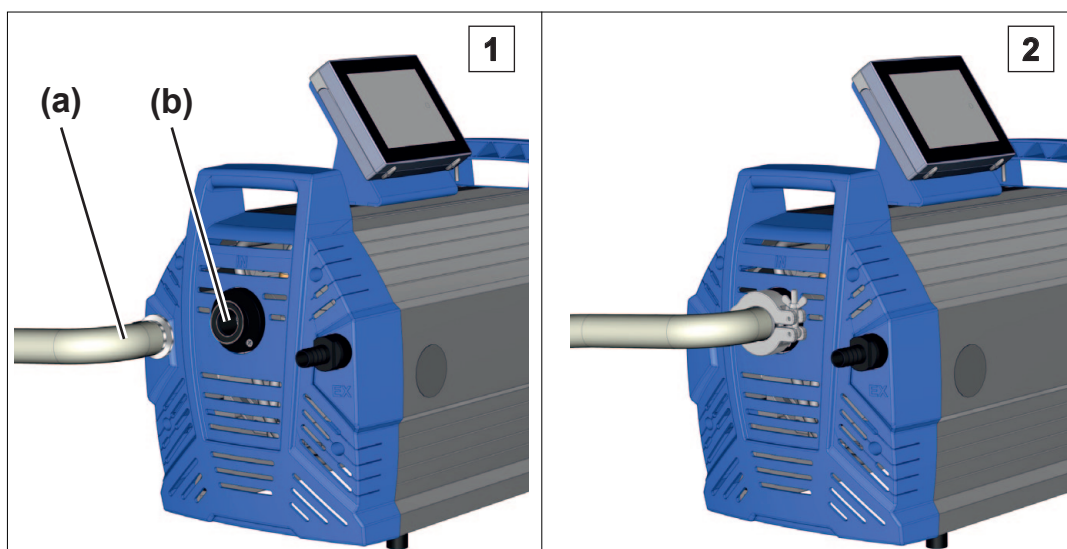

1. Take a vacuum hose **(a)** with a small flange connection KF DN 25.
2. Attach the vacuum hose to pump inlet **(b)** with a centering ring and clamping ring.



Observe the following points for optimum results:

- ⇒ Keep the vacuum line as short as you can with as large a cross-section as possible.
- ⇒ Alternatively, you can connect a vacuum hose via an adapter to the hose nozzle DN 15 mm → see accessories in **8.2 Ordering information on page 80**.

4.4.2 Outlet connection (EX)

| | |
|---|---|
|  | WARNING |
| | <p>Risk of bursting due to overpressure inside the outlet line.</p> <p>Inadmissibly high pressure in the outlet line can cause the vacuum pump to burst or damage seals.</p> <ul style="list-style-type: none"> ⇒ The outlet line (exhaust gas, gas outlet) must always be clear and non-pressurized. ⇒ Always route the exhaust gas hose with a fall or take measures to prevent condensate from flowing back into the vacuum pump. ⇒ Observe the maximum admissible pressures and pressure differences. |

Connect the exhaust gas hose

→ Example
Exhaust gas connection at the outlet EX

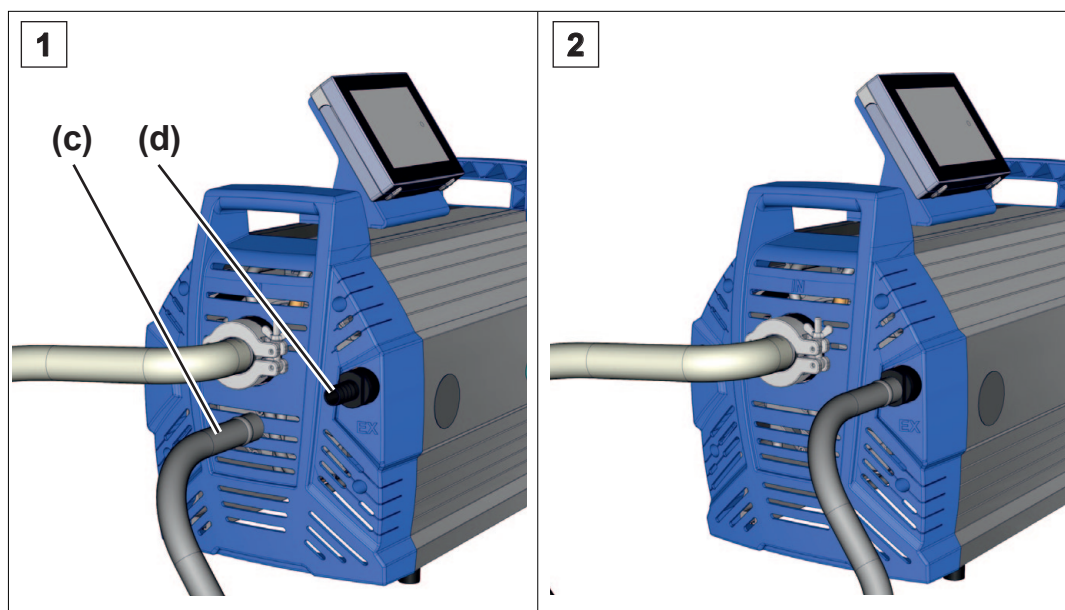

1. Take a vacuum hose (c), d_i 15 mm diameter.
2. Slide the outlet hose onto hose nozzle (d) and route the hose into a fume hood if necessary. If necessary fix the outlet hose, e. g., with a hose clip.

4.4.3 Venting connection (option)

| | |
|---|---|
|  | DANGER |
| | <p>Risk of explosion by venting with air.</p> <p>Depending on the application, venting can cause explosive mixtures to form or other hazardous situations to arise.</p> <ul style="list-style-type: none"> ⇒ Never vent processes with air which could form an explosive mixture. ⇒ In the case of flammable substances, use only inert gas for venting, e. g., nitrogen (max. 1.2 bar/900 Torr abs.). |

The diaphragm pump and controller have *no* direct ventilation connection. You can connect different venting valves, e. g., the supplied **VACUU-SELECT® Sensor** with integral venting valve.

VACUU-SELECT®
Sensor with venting
valve

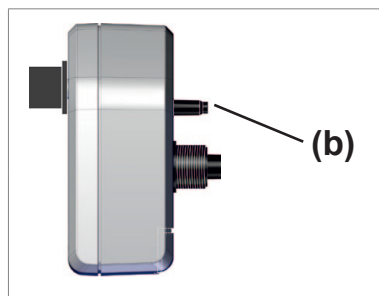

The ventilation connection **(b)** for a **VACUU-SELECT® Sensor** is described below.

Alternatively you can use a larger valve, e. g., a **VB M-B** (#20674217) for faster venting.

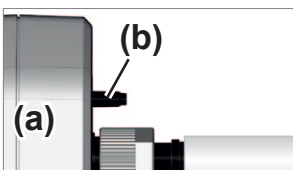

Vent with ambient air¹

For venting **(b)** with ambient air, nothing needs to be connected to the sensor **(a)**.

Vent with inert gas – connect venting valve¹

Required connection material: Hose for hose nozzle, e. g., silicone tube 4/5 mm

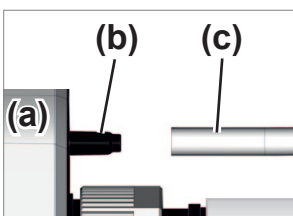

⇒ Attach hose **(c)** to the connection of venting valve **(b)** and connect inert gas (max. 1.2 bar/900 Torr, abs.).

- Venting valve with hose for venting with inert gas².



¹ Not applicable to sensors without an integrated venting valve.
² Avoid overpressure.

4.4.4 Gas ballast (GB)

Use of ambient air as gas ballast

→ Example
Position of gas
ballast valve

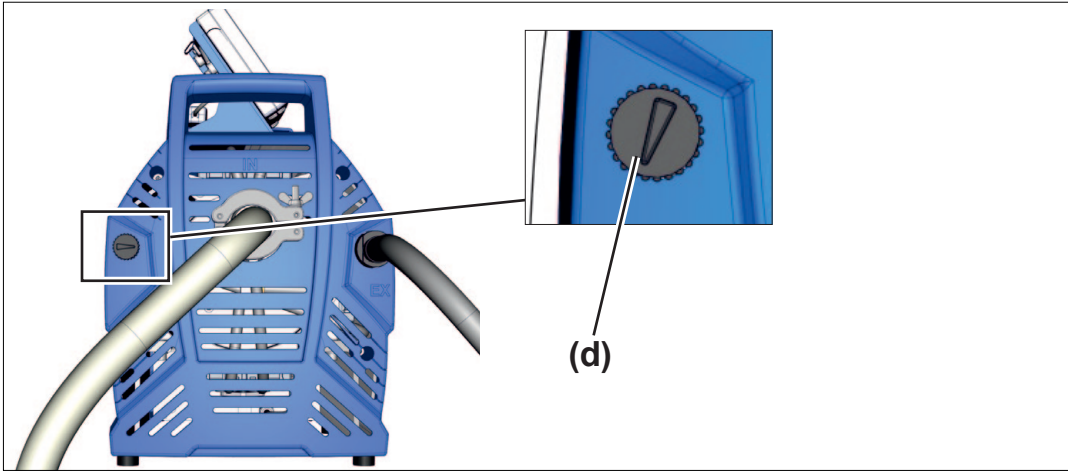

If ambient air is to be used as gas ballast, nothing needs to be connected at the diaphragm pump; gas ballast valve (d).
→ see also chapter 5.2.2 Operation with gas ballast on page 42

Use of inert gas as gas ballast – OPTION

Prepare inert gas
connection (GB)

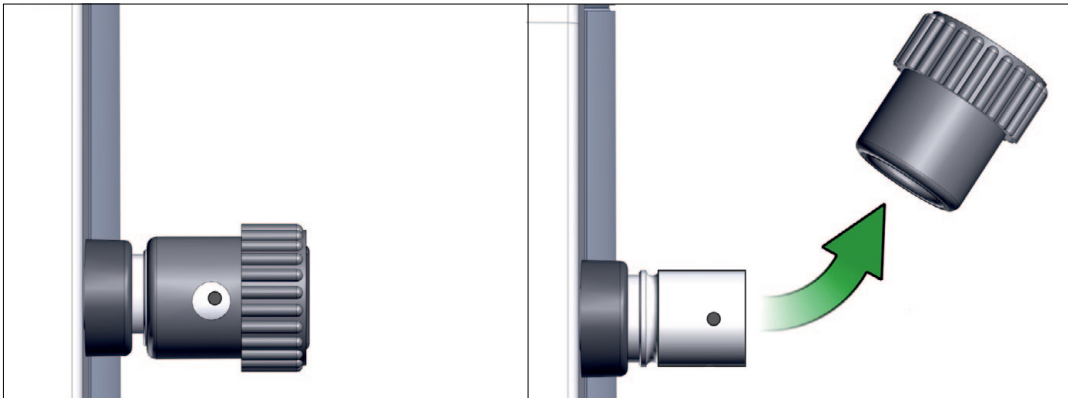

⇒ Remove the black gas ballast cap and connect a gas ballast adapter in its place.

i Connection options and adapter for hose nozzle or small flange are available on request.

4.4.5 Electrical connection

Pump electrical connection

→ Example
Electrical connection
for pump

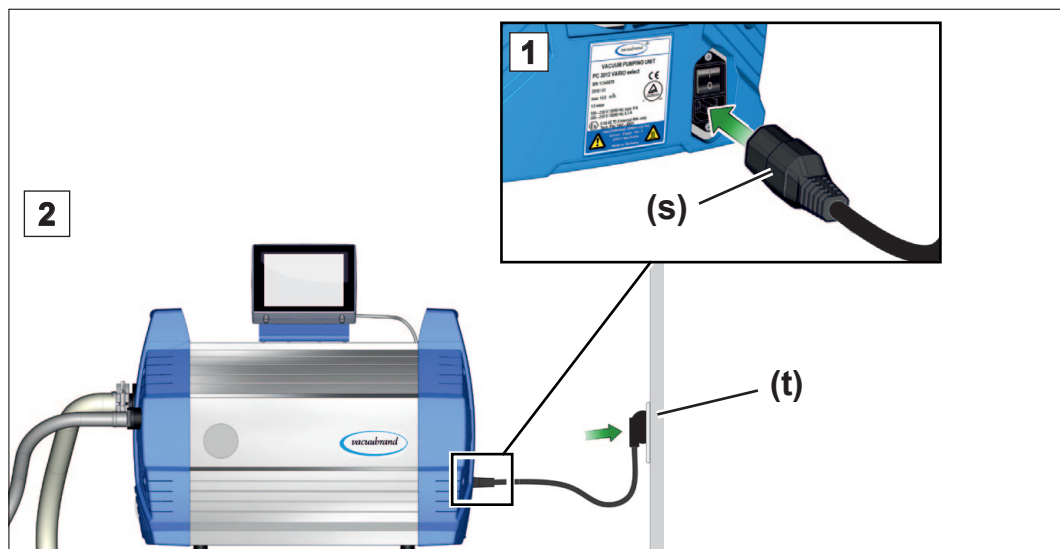

1. Plug the connector (s) on the power cable into the power connection of the vacuum pump.
2. Plug power plug (t) into the power outlet.
 - Vacuum pump electrically connected.

IMPORTANT!

⇒ Lay the power cable such that it cannot be damaged by sharp edges, chemicals, or hot surfaces.

Power connections with country code

Diagrams of
standard power
connections with
grounding contact

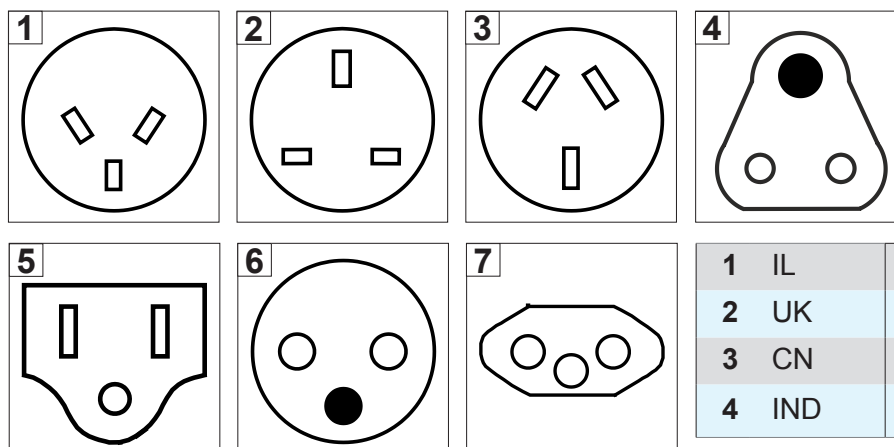

The vacuum pump is delivered ready for use with the appropriate power plug.

IMPORTANT!

- ⇒ Use the power plug which fits your power supply.
 - ⇒ Do not use multiple sockets connected in series as the power connection.
-

5 Commissioning (operation)

5.1 Switch on

Switch pump on

Switch pump on

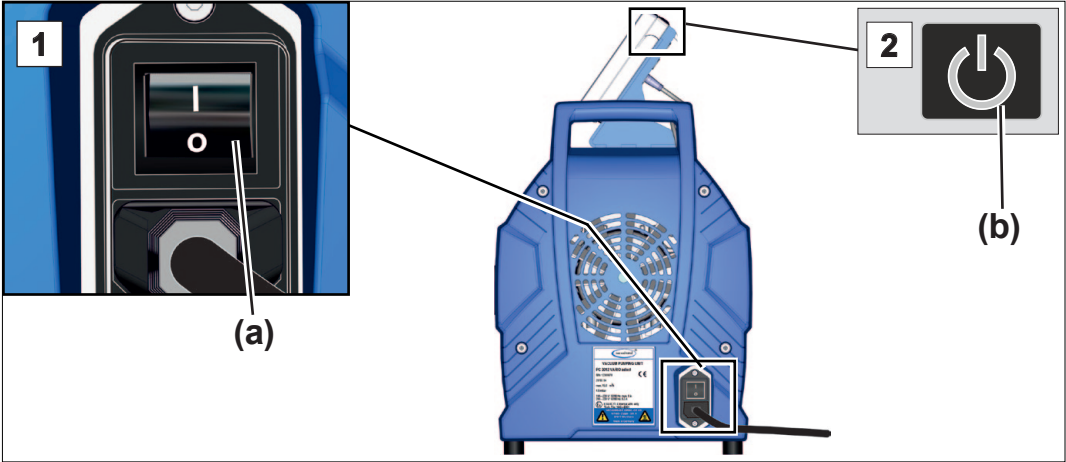

1. Switch rocker switch (a) on – switch position I.
2. Press ON/OFF button (b) on the controller.
 - The start screen is displayed.
 - After approx. 30 seconds, the process screen with the operating elements appears on the controller display.

5.2 Operation

Operation with vacuum controller

Apart from the chapters Switch on and Switch off, this manual describes the mechanical structure of the diaphragm pumps.

Operation of the installed vacuum controller and its functions are described in the separate **VACUU-SELECT** manual.

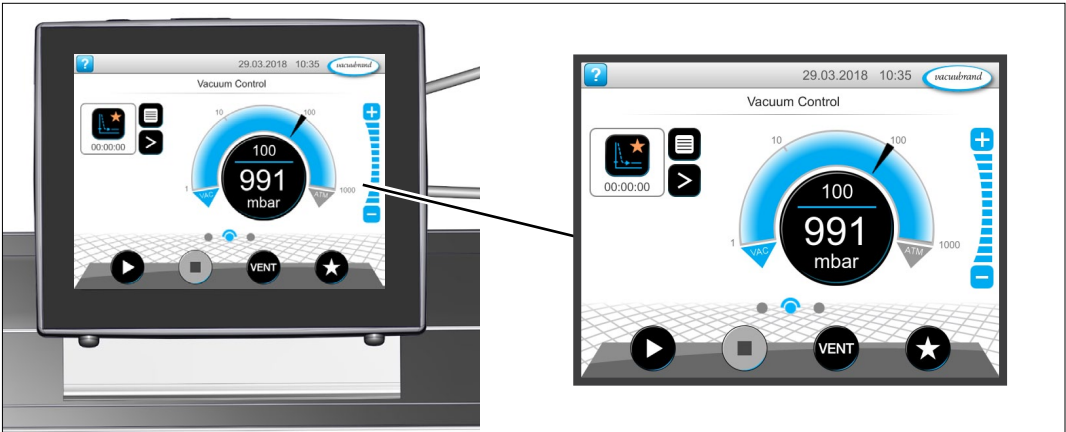

Process screen

Vacuum controller process screen

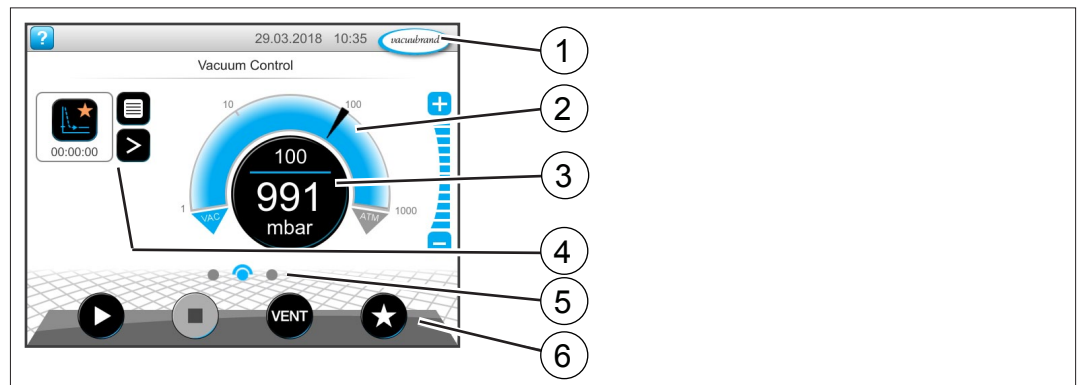

- 1 Status bar
- 2 Analogue pressure display – pressure curve
- 3 Digital pressure display – pressure value (target value, actual value, pressure unit)
- 4 Process screen with context features
- 5 Screen navigation
- 6 Operating elements for control

Operating elements

Vacuum controller operating elements

| Button | | Function |
|--------|--------|---|
| Active | Locked | |
| | | Start ▶ Start application – only available on the process screen. |
| | | Stop ▶ Stop application – always possible. |
| | | VENT – vent the system (option) ▶ Press button < 2 sec = vent briefly; control continues. |
| | | ▶ Press button > 2 sec = vent to atmospheric pressure; vacuum pump is stopped. |
| | | ▶ Press button during venting = venting is stopped. |
| | | Favorites ▶ View Favorites menu. |

* Button is only displayed if venting valve is connected or activated.

5.2.1 Operation (→ see description of controller)

Start the vacuum controller

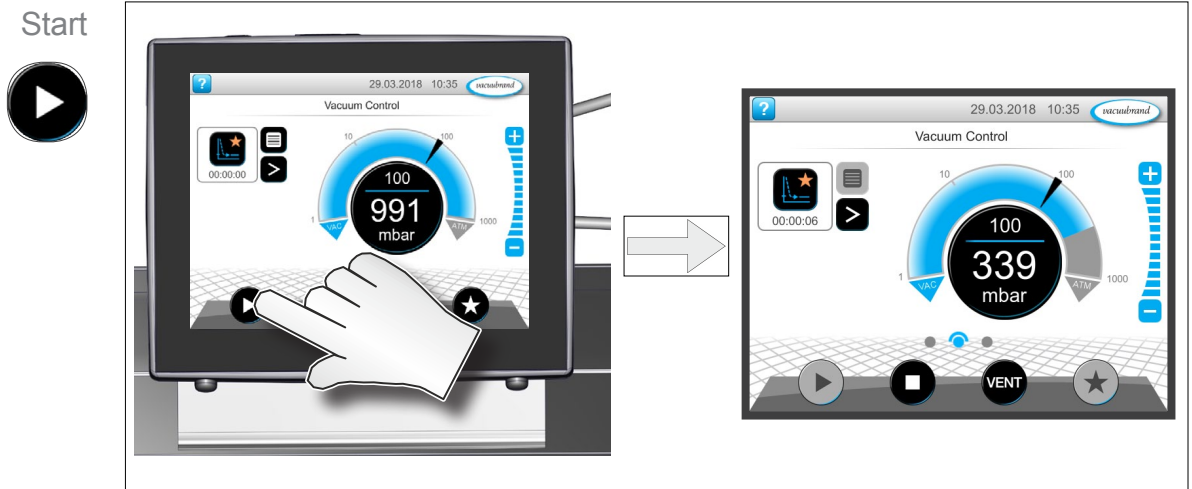

Stop the vacuum controller

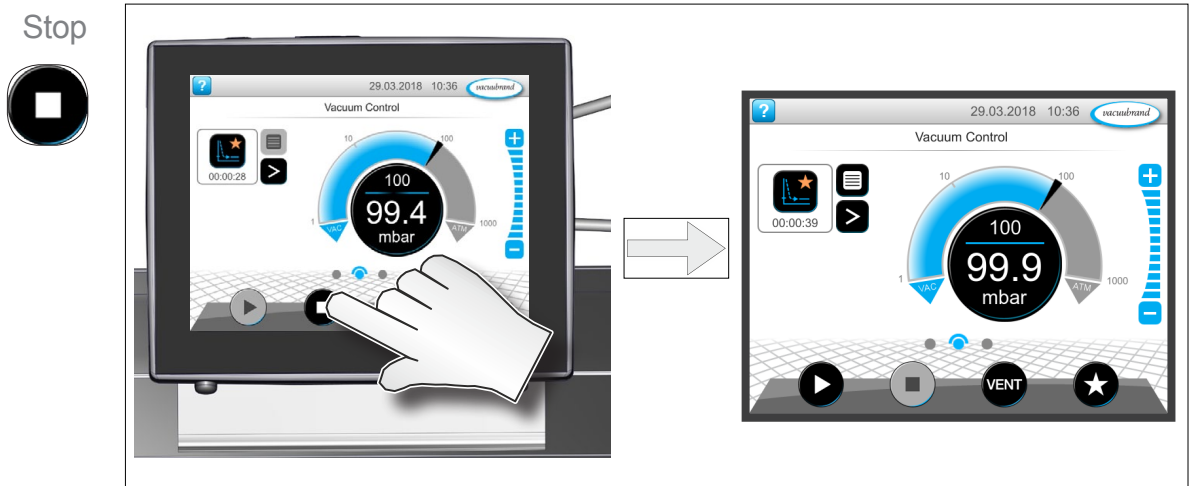

Venting

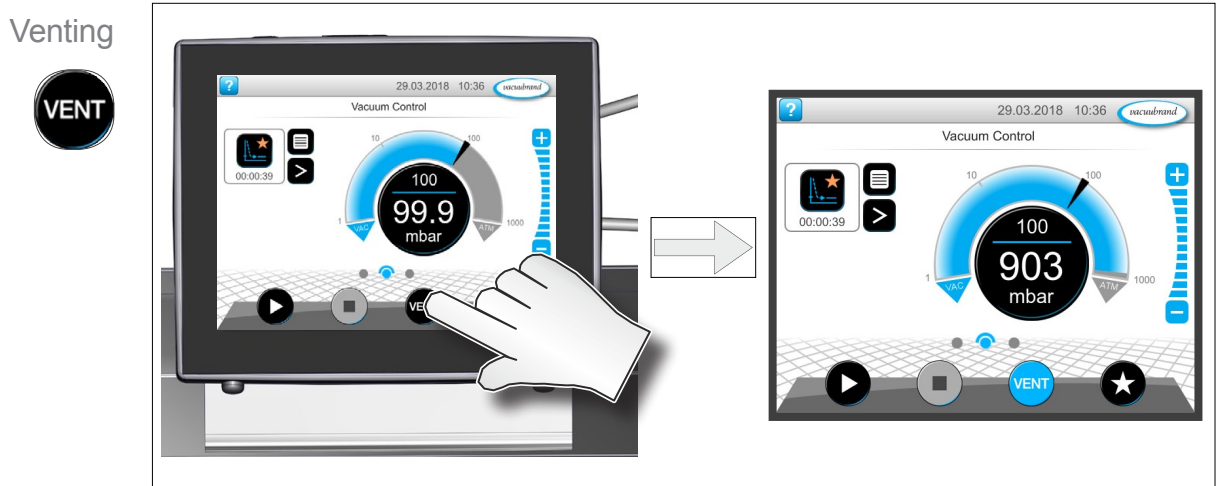

5.2.2 Operation with gas ballast

Meaning

The provision of gas ballast (= addition of gas) ensures that vapors do not condense inside the vacuum pump but are instead ejected from the pump. This makes it possible to pump larger amounts of condensable vapors, and also prolongs the service life. The ultimate vacuum with gas ballast is slightly higher.

Open/close the gas ballast valve

→ Example
Operate gas ballast
valve

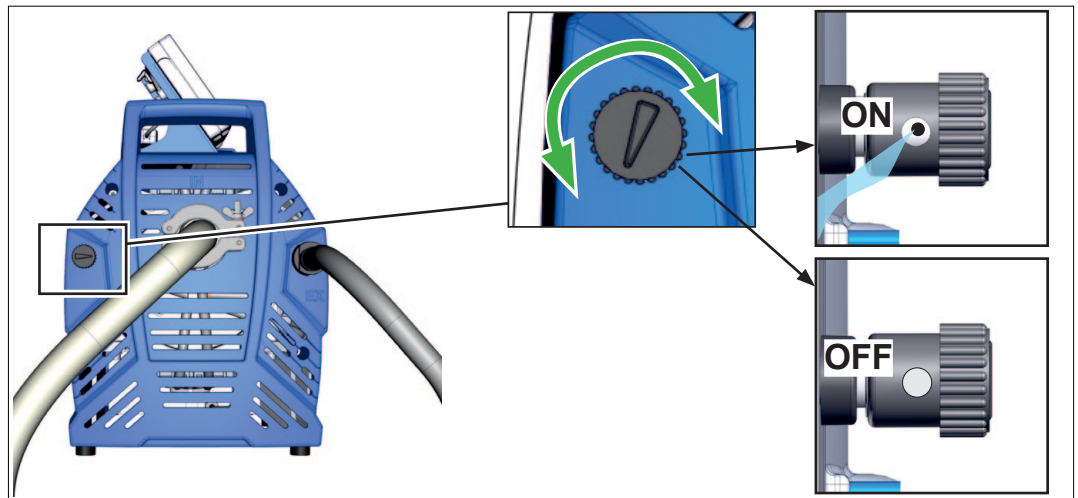

- ⇒ Turn the black gas ballast cap in any direction to open or close the gas ballast valve.
- ⇒ Evacuate condensable vapors, e. g., water vapor, solvents, etc. preferably only with the vacuum pump at operating temperature and with the gas ballast valve open.

IMPORTANT!

- ⇒ If necessary, connect inert gas as a gas ballast to prevent the formation of explosive mixtures.
- ⇒ Observe the admissible pressure at the gas ballast connection, max. 1.2 bar/900 Torr abs.



If the gas volume in the vacuum pump is low, a gas ballast may be able to be eliminated in these cases.

5.3 Shutdown (switch off)

Take the pump out of operation

Switch pump off

1. Stop the process and let the diaphragm pump run on for about 30 minutes, with open gas ballast or open inlet.
 - Condensate and media residues will be flushed out of the vacuum pump.

IMPORTANT! ⇒ Prevent deposits and rinse condensate out of the pump.

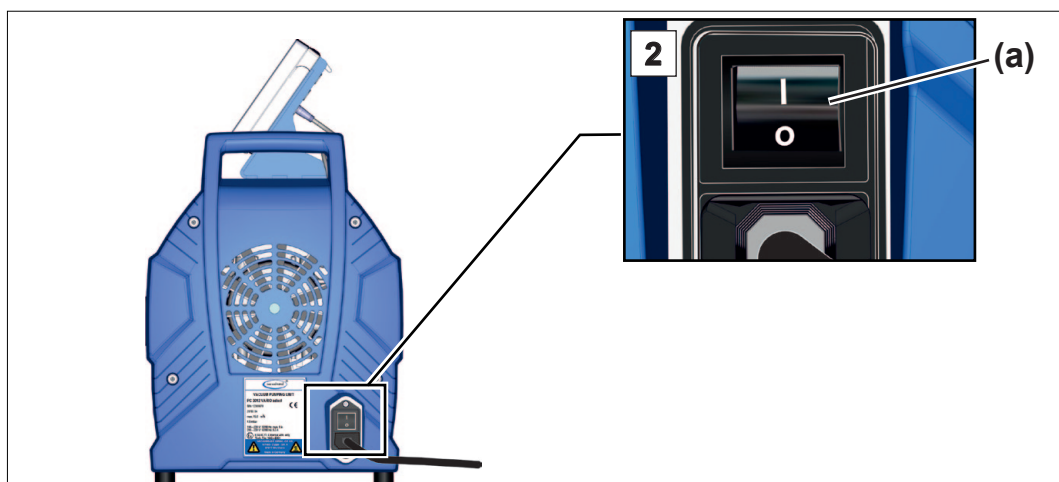

2. Switch rocker switch **(a)** off – switch position **O**.
 - Pump switched off.
3. Disconnect the pump from the apparatus.
4. Check the pump for dirt and damage.

5.4 Storage

Store the vacuum pump

1. Clean the vacuum pump if dirty.
2. Recommendation: Perform preventive maintenance before storing the vacuum pump. This is especially important if it ran more than 15,000 operating hours.
3. Close the suction and outlet lines, e. g., with the transport caps.
4. Package the vacuum pump such that it is protected from dust; enclose desiccants if necessary.
5. Store the vacuum pump in a cool, dry location.

IMPORTANT!

If damaged parts are stored for operational reasons, these should be clearly identified as **not ready for use**.

6 Troubleshooting

6.1 Technical support

⇒ To identify errors and potential remedies, please refer to the troubleshooting table *Error – Cause – Remedy*.

Technical support

For technical assistance or errors for which you require additional support, please contact our [Service Department](#)¹. or your local distributor.

 Only operate the product if it is in perfect working condition.

- ⇒ Observe the recommended maintenance intervals to ensure a fully functional system.
- ⇒ Send defective devices to our Service Department or your local distributor for repair!

6.2 Error – Cause – Remedy

Error – Cause – Remedy

| Error | Possible cause | ✓ Remedy | Personnel |
|--|--|---|------------|
| Readings deviate from the reference standard | <ul style="list-style-type: none"> ▶ Vacuum sensor dirty. ▶ Moisture in the sensor. ▶ Sensor defective. ▶ Sensor measures incorrectly. | <ul style="list-style-type: none"> ✓ Clean sensor measuring chamber. ✓ Allow sensor measuring chamber to dry, e. g., by pumping. ✓ Calibrate sensor with reference gauge. ✓ Replace defective components. | Specialist |
| Sensor does not pass on measured value | <ul style="list-style-type: none"> ▶ No voltage applied. ▶ VACUU·BUS plug-in connection or cables defective or not connected. | <ul style="list-style-type: none"> ✓ Check VACUU·BUS plug-in connection and cables to the controller. | Operator |
| | <ul style="list-style-type: none"> ▶ Sensor defective. | <ul style="list-style-type: none"> ✓ Replace defective components. | Specialist |

¹ -> Phone: +49 9342 808-5660, fax: +49 9342 808-5555, service@vacuubrand.com

Error – Cause –
Remedy



| Error | ▶ Possible cause | ✓ Remedy | Personnel |
|---------------------------------|---|---|------------------|
| Venting valve does not operate | <ul style="list-style-type: none"> ▶ No voltage applied. ▶ VACUU·BUS plug-in connection or cables defective or not connected. ▶ Venting valve dirty. ▶ Venting valve in sensor defective. | <ul style="list-style-type: none"> ✓ Check VACUU·BUS plug-in connection and cables to the controller. ✓ Clean venting valve. ✓ Perform component detection in VACUU·SELECT – see: Main menu/ Administration/ VACUU·BUS. ✓ If necessary, use another external venting valve. | Specialist |
| Vacuum pump does not start | <ul style="list-style-type: none"> ▶ Overpressure in the outlet line. ▶ Condensation in the vacuum pump. | <ul style="list-style-type: none"> ✓ Open the outlet line. ✓ Ensure clear passage. | Operator |
| | <ul style="list-style-type: none"> ▶ Pump switched off. ▶ Power plug not correctly plugged in or pulled out. ▶ VACUU·BUS plug-in connection or cables defective or not connected. | <ul style="list-style-type: none"> ✓ Switch pump on using rocker switch. ✓ Check power supply and cable. ✓ Check VACUU·BUS plug-in connection and cables to the controller. | Operator |
| | <ul style="list-style-type: none"> ▶ Motor overloaded. ▶ Thermal protection has been triggered. | <ul style="list-style-type: none"> ✓ Allow the motor to cool down. ✓ Clear error manually: → Unplug pump from the power supply → Eliminate cause of error → Switch pump back on | Specialist |
| No or very little suction power | <ul style="list-style-type: none"> ▶ Leak in the suction line or apparatus. | <ul style="list-style-type: none"> ✓ Check suction line and apparatus for leaks. | Operator |

Error – Cause – Remedy

| Error | ▶ Possible cause | ✓ Remedy | Personnel |
|---------------------------------|---|--|------------------|
| No or very little suction power | ▶ Vacuum line too long or cross-section too small. | ✓ Use a shorter vacuum line with a larger cross-section. | Resp. specialist |
| | ▶ Condensate inside the vacuum pump. | ✓ Allow vacuum pump to run for a few minutes with the suction nozzle open. | Operator |
| | ▶ Deposits inside the vacuum pump. | ✓ Clean and check pump heads. | Specialist |
| | ▶ Diaphragms or valves defective. | ✓ Replace diaphragms and valves. | Specialist |
| | ▶ High level of vapor generated in the process. | ✓ Check process parameter. | Specialist |
| | ▶ Gas ballast open | ✓ Close the gas ballast | Operator |
| | ▶ Gas ballast cap porous or no longer present. | ✓ Check gas ballast cap. ✓ Replace defective components. | Operator |
| No display | ▶ Pump switched off. ▶ Power plug not correctly plugged in or pulled out. ▶ VACUU·BUS plug-in connection or cables defective or not connected. ▶ Controller switched off or defective. | ✓ Switch pump on using rocker switch. ✓ Switch on controller. ✓ Check power supply and cable. ✓ Check VACUU·BUS plug-in connection and cables to the controller. ✓ Replace defective components. | Operator |
| Loud operating noises | ▶ No hose installed at outlet. | ✓ Check hose and install it correctly. | Operator |

| Error | ▶ Possible cause | ✓ Remedy | Personnel |
|-----------------------|---|---|------------------|
| Loud operating noises | <ul style="list-style-type: none">▶ Ball bearing defective.▶ Outlet line open. | <ul style="list-style-type: none">✓ Service the vacuum pump and replace defective parts or send in the device.✓ Check outlet line connections.✓ Connect the outlet line to an extraction system or fume hood. | Specialist |

7 Cleaning and maintenance

| | |
|--|--|
|  | <p>WARNING</p> |
|  | <p>Danger due to electrical voltage.</p> <ul style="list-style-type: none"> ⇒ Switch the device off before cleaning or maintenance work. ⇒ Unplug the power plug from the socket. |
|  | <p>Risk from contaminated parts.</p> <p>Pumping hazardous media can result in hazardous substances adhering to internal parts of the pump.</p> <ul style="list-style-type: none"> ⇒ Wear your personal protective equipment, e. g., protective gloves, eye protection and, if necessary, respiratory protection. ⇒ Decontaminate the vacuum pump before opening it. If necessary have decontamination carried out by an external service provider. ⇒ Take safety precautions according to your instructions for handling hazardous substances. |

NOTE

Damage possible if work is performed incorrectly.

- ⇒ Have maintenance work performed by a trained professional or at least by a trained person.
- ⇒ Recommendation: Before carrying out maintenance for the first time, please read through all the instructions to get an overview of the required service work.

7.1 Information on service work

Recommended maintenance intervals

| Maintenance intervals* | If required | 15,000 h |
|-----------------------------------|-------------|----------|
| Replace diaphragms | | X |
| Replace valves | | X |
| Replace O-rings | | X |
| Clean or replace molded PTFE hose | X | |
| Clean the vacuum pump | X | |

* Recommended maintenance interval according to operating hours and under normal operating conditions; depending on the environment and area of application, we advise performing cleaning and maintenance as needed.

Recommended aids

→ Example
Recommended aids
for cleaning and
maintenance



Protective gloves

IMPORTANT!

⇒ Always wear your personal protective equipment when performing activities which may bring you into contact with hazardous substances.

Tools needed for maintenance

→ Example Tools



| No. | Tool | Size |
|----------|--|--------|
| 1 | Service kit | |
| | Service kit MD 12C / MV 10C VARIO select #20696839 | 1x |
| | or | |
| | Service kit ME 16C VARIO select #20696867 | 2x |
| 2 | Diaphragm wrench #20636554 | SW66 |
| 3 | Flat nose pliers | |
| | To secure the hose clips | |
| 4 | Flat-head screwdriver | |
| | To open hose clips | Size 1 |
| 5 | Phillips screwdriver | |
| | Screw fittings, controller base | Size 1 |
| 6 | Torx screwdriver | |
| | Loosen/secure clamping claws | TX20* |
| 7 | Hex key | |
| | Screw fittings, side panels | Size 5 |
| | Screw fittings, head cover | Size 5 |
| | Screw fittings, housing sections with handle | Size 4 |
| | Loosen/secure side panel retaining plates | Size 4 |
| | Screw fitting, outlet holder | Size 3 |
| 8 | Torque wrench, adjustable 2–10 Nm | |

* In the example here with bit support

7.2 Cleaning

IMPORTANT!

This chapter does not contain descriptions for decontamination of the product. This chapter describes simple measures for cleaning and care.

⇒ Before cleaning, switch off the diaphragm pump.

7.2.1 Diaphragm pump

Clean the surfaces



Clean dirty surfaces with a clean, slightly damp cloth. We recommend using water or mild soapy water to moisten the cloth.

7.2.2 Clean or replace molded PTFE hoses

Maintenance provides the opportunity to check the components of the diaphragm pump, including the hoses.

⇒ Clean the inside of very dirty molded hoses, e. g., using a pipe cleaner or similar.

⇒ Replace brittle and defective molded hoses.

7.2.3 Clean or replace the controller

During maintenance, the controller can be disconnected and removed.

Clean the surfaces



⇒ Clean dirty surfaces with a clean, slightly damp cloth. We recommend using water or mild soapy water to moisten the cloth.

⇒ Reattach the controller after maintenance work has been completed.

7.3 Diaphragm pump maintenance

7.3.1 Maintenance items

Items that require maintenance

→ Example
Diaphragm
pump, front,
semi-transparent
view

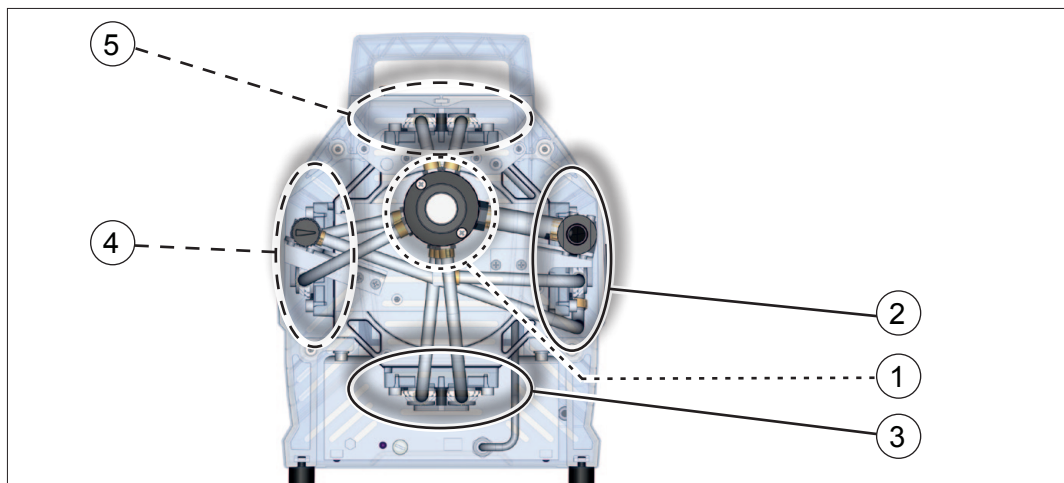

Meaning

Maintenance items and sequence

- | | |
|---|------------------------------|
| 1 | Suction/pressure distributor |
| 2 | Right pump head pair |
| 3 | Bottom pump head pair |
| 4 | Left pump head pair |
| 5 | Top pump head pair |



Straightforward maintenance due to split work steps. Observe the recommended sequence of maintenance steps according to the table:

- ⇒ Replace the O-ring and pressure relief valve in the suction/pressure distributor.
- ⇒ Next, on one pump head pair, first replace the diaphragms.
- ⇒ Then change the inlet/outlet valves.
- ⇒ Repeat these steps on the next pump head pair.

7.3.2 Preparation

Disassemble the controller and base

→ see also chapter: *4.3 Controller base on page 30*

Disassemble the device and housing sections

Disassemble the front housing section



1. Switch the diaphragm pump off and unplug the power plug.

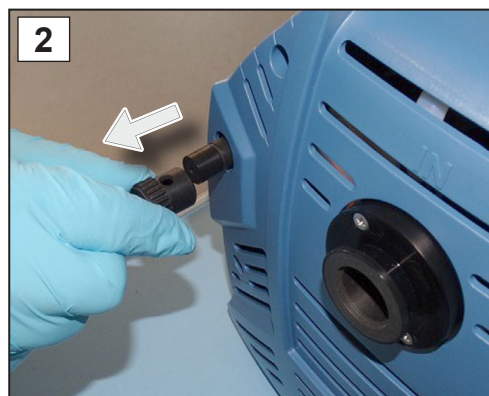

2. Remove the cap from the gas ballast.

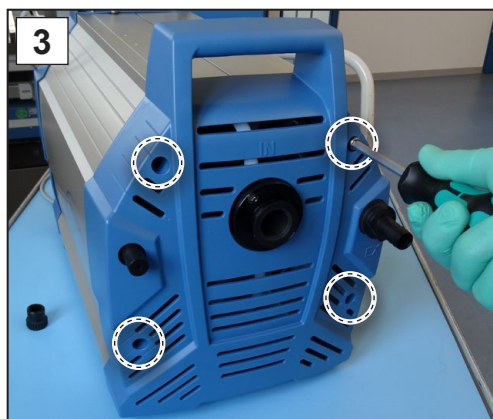

3. Unscrew the 4 screws from the front housing section; hex key size 4.

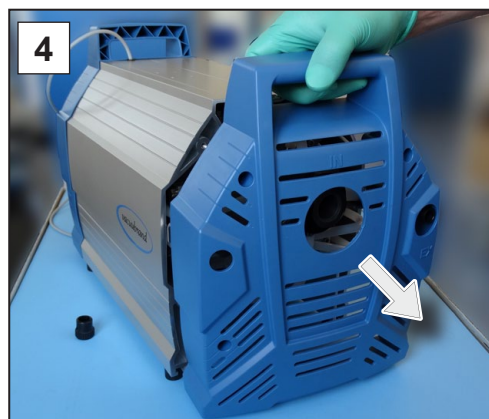

4. Remove the front housing section and set it aside.

Disassemble the outlet hose

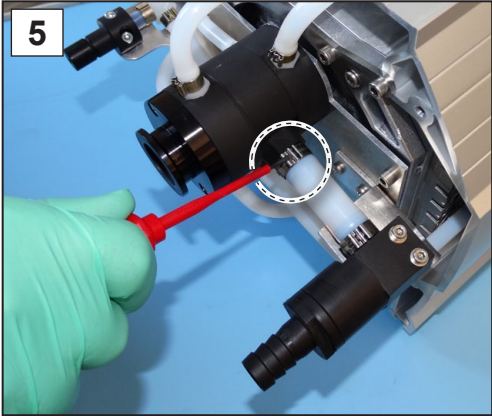

5. Open the hose clip on the molded hose leading to the outlet; flat-head screwdriver size 1.

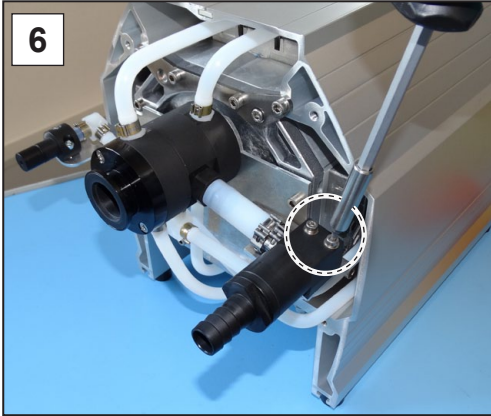

6. Unscrew the 2 screws from the outlet holder; hex key size 3.

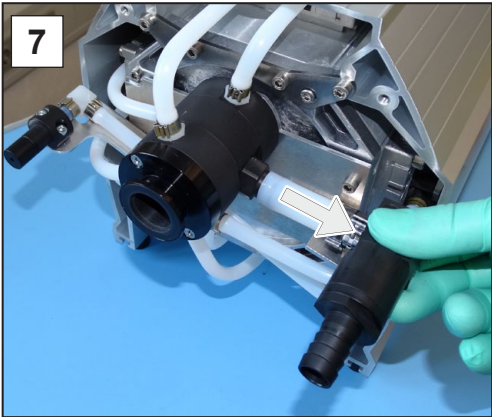

7. Pull the outlet holder, together with the hose, off the hose nozzle.

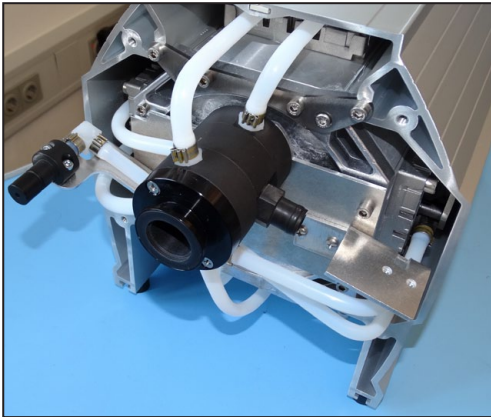

Diaphragm pump is prepared

7.3.3 Suction/pressure distributor maintenance

This description only applies to the following diaphragm pumps: MD 12C and MV 10C VARIO select.

Exploded drawing of suction/pressure distributor (example)

→ Example
Pressure relief valve

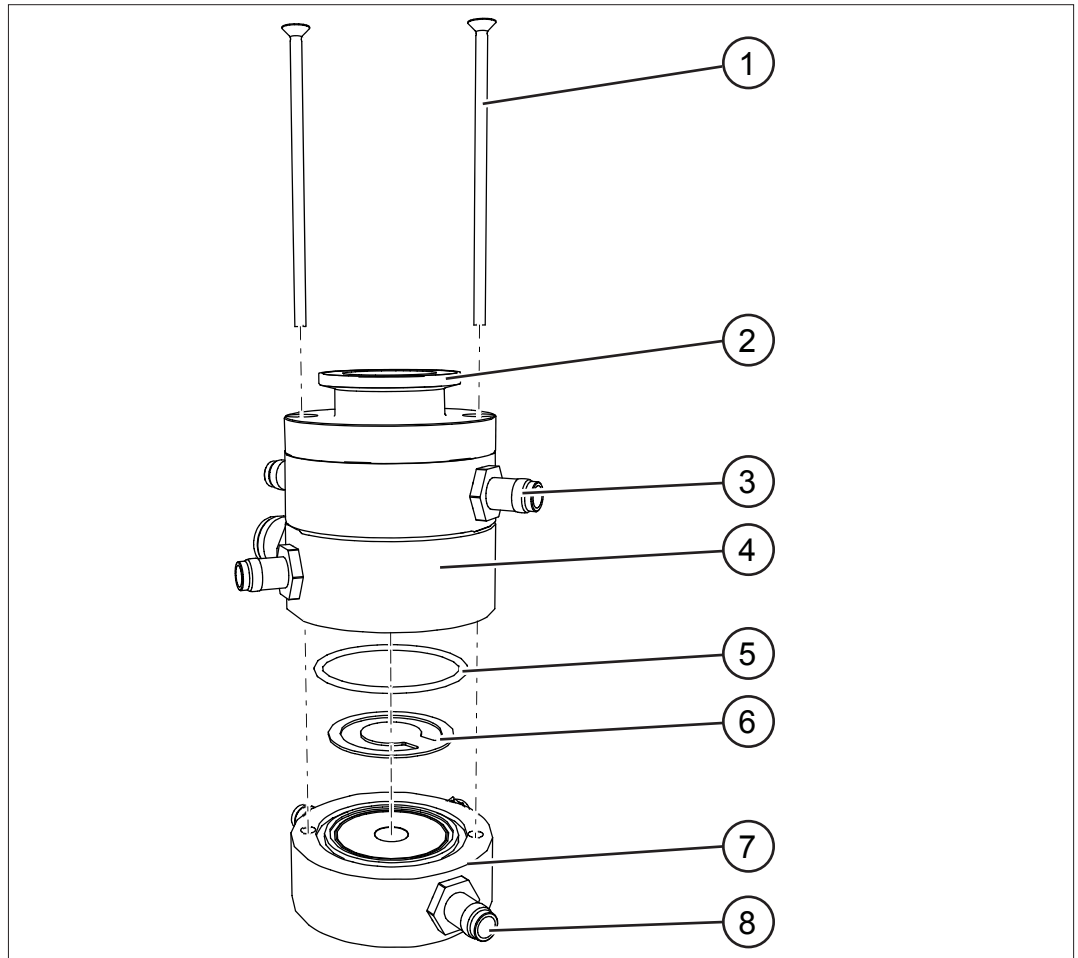

Meaning

Pressure relief valve + O-ring maintenance

- | | |
|---|---------------------------|
| 1 | Countersunk screw M4x80 |
| 2 | Connection DN 25 |
| 3 | Hose nozzle |
| 4 | Suction distributor |
| 5 | O-ring 40 x 2 |
| 6 | Pressure relief valve D37 |
| 7 | Pressure distributor |
| 8 | Hose nozzle |

Replace pressure relief valve + O-ring

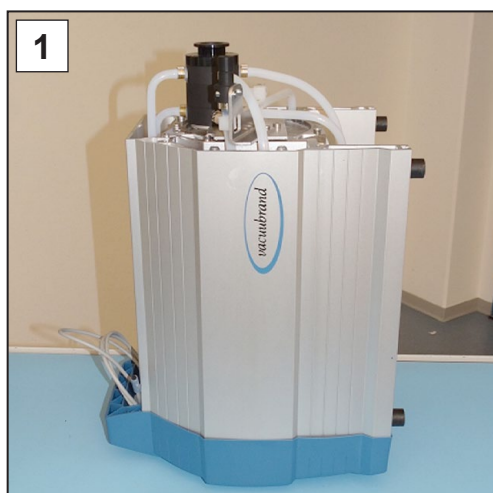

1. Place the vacuum pump on a clean, stable surface as shown.

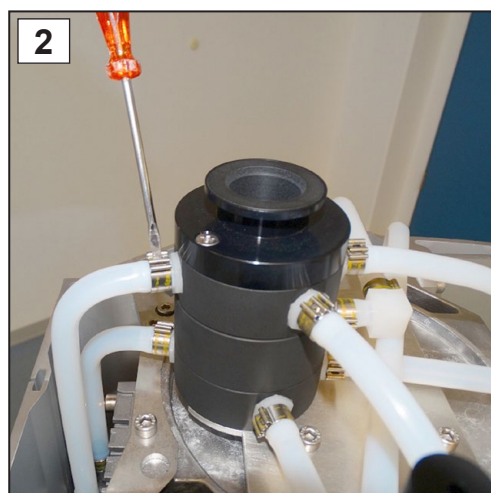

2. Only open the hose clips above the pressure distributor; flat-head screwdriver size 1.



3. Remove the molded hoses one by one from the hose nozzles.

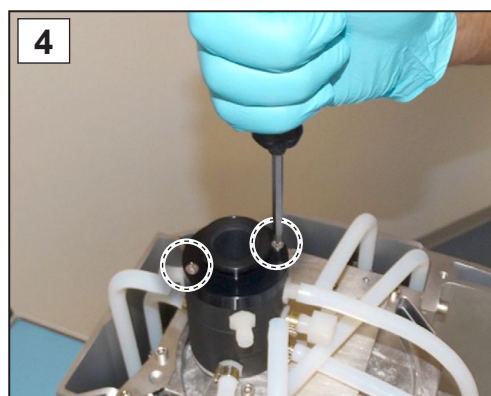

4. Unscrew the screw fittings. Phillips screwdriver size 2.



5. Remove the suction distributor with the screws and put it aside.

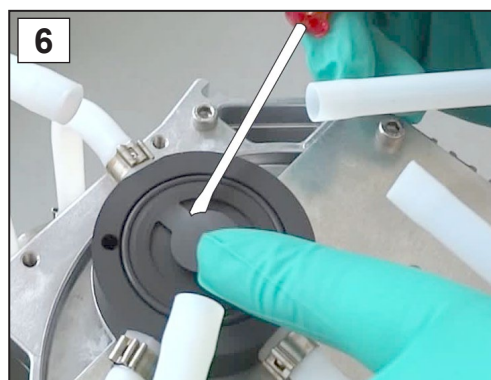

6. Carefully remove the used pressure relief valve, e. g., with a sturdy plastic rod or a narrow flat-head screwdriver.

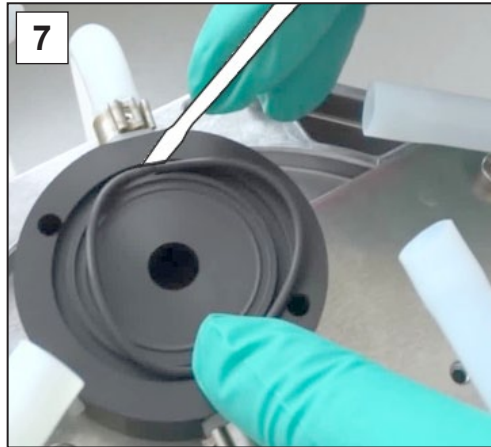

7. Replace the used O-ring.

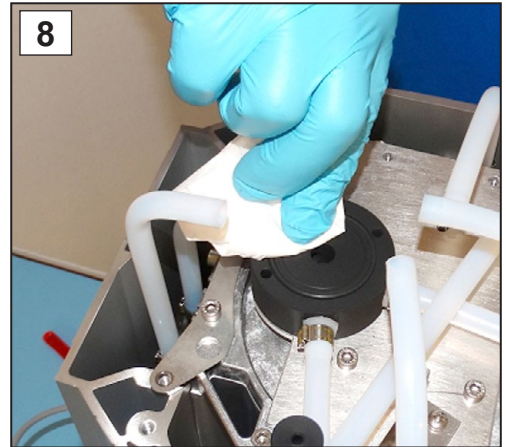

8. Clean the pressure distributor if necessary.

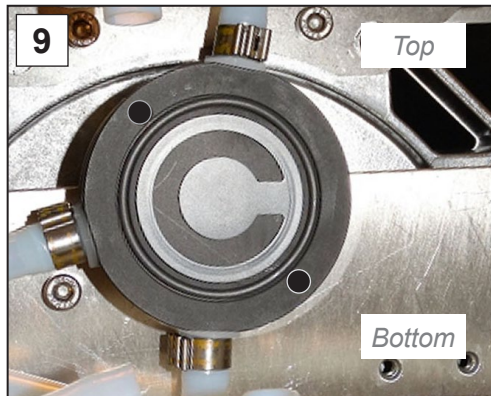

9. Place the new pressure relief valve on the clean surface. Ensure the pressure relief valve is positioned correctly on the pressure distributor.

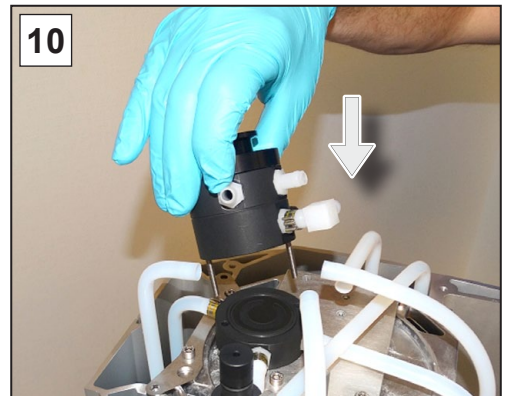

10. Position the suction distributor with screws and wind in the screw fittings until hand-tight; Phillips screwdriver size 2.



11. Push the molded hoses back into place on the hose nozzles.



12. Secure the hose clips on the hose nozzles, e. g., with flat nose pliers.

7.3.4 Change the diaphragms and valves

Disassemble the next housing sections

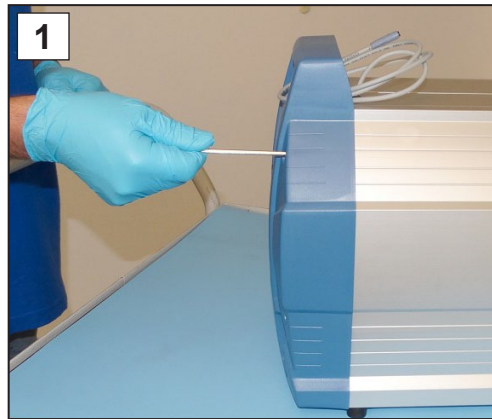

1. Unscrew the 4 screws from the rear housing section; hex key size 4.

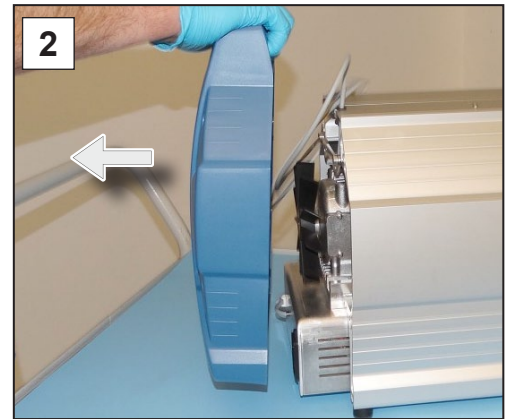

2. Remove the housing section and set it aside.

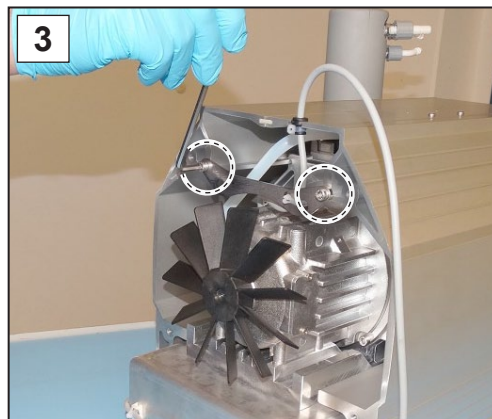

3. Unscrew the screws from the side panel retaining plate; hex key size 4.

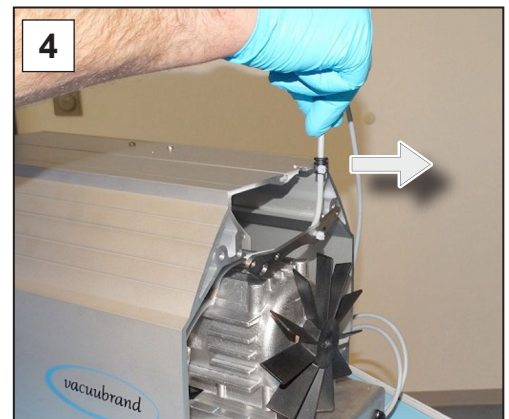

4. Route the cable out of the recess.

Remove the side panel

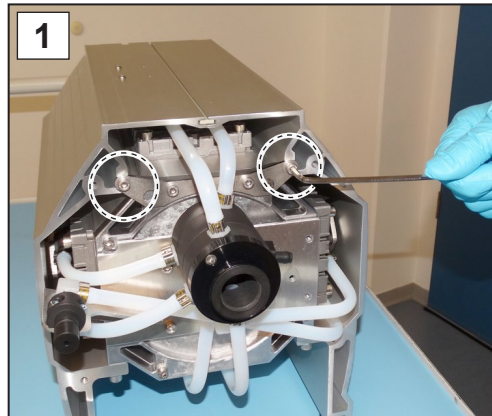

1. Unscrew the 2 outer screws from the retaining plate; hex key size 4.



2. Place the pump carefully on its side.

Remove the right side panel

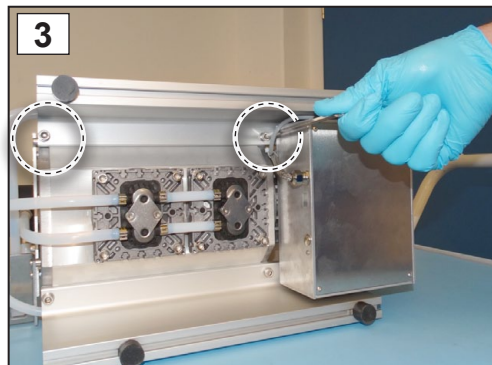

3. Unscrew the screw fittings from the side panel; hex key size 5.

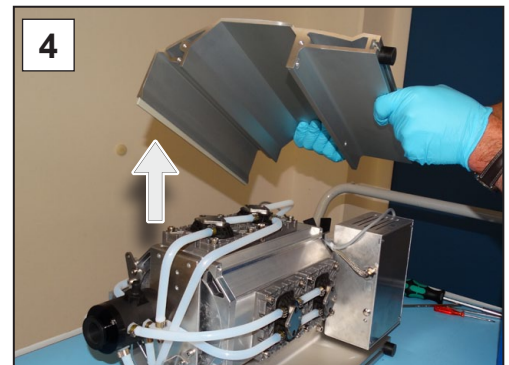

4. Lift the side panel off the pump. The lower side panel remains attached for now to provide stabilization.

IMPORTANT!

- ⇒ Service the pump head pairs one after the other.
- ⇒ Always change the diaphragms and valves completely in the pump heads.

Exploded drawing of pump head (example)

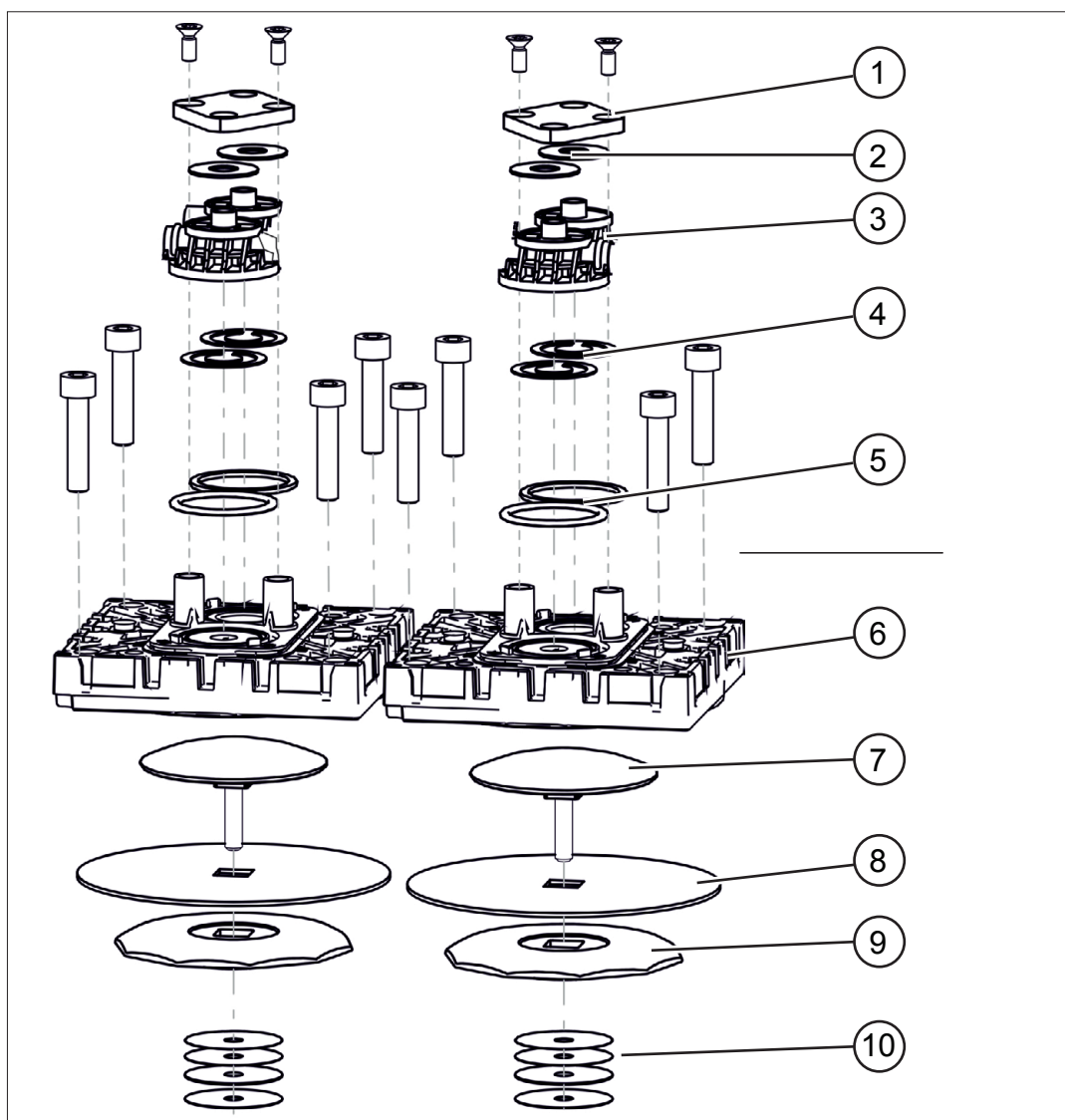

Valve maintenance

- 1 Clamping claw + screw fittings
- 2 Disc springs
- 3 Valve terminals
- 4 Valves
- 5 O-ring size 26 x 2

Diaphragm maintenance

- 6 Head cover + screw fittings
- 7 Diaphragm clamping disc with square head screw
- 8 Diaphragms
- 9 Diaphragm support disc
- 10 Spacer discs, max. 4 per pump head

Right pump head pair

→ Example
Right pump head pair

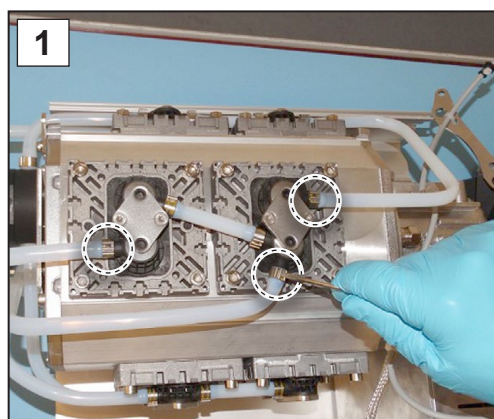

1. Open the hose clips on the outer hoses. Flat-head screwdriver size 1.

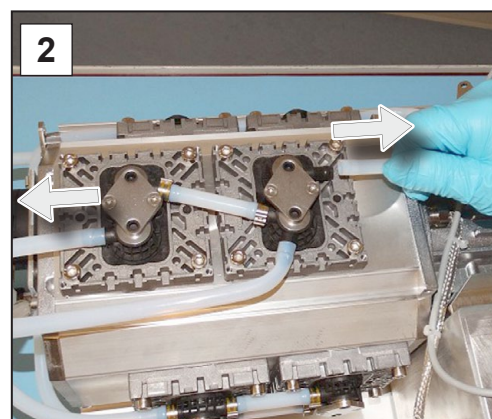

2. Pull off the molded hoses.

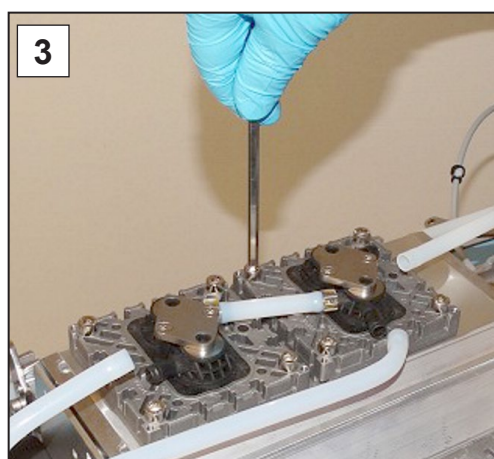

3. Unscrew the socket head screws from the head covers. Hex key size 5.

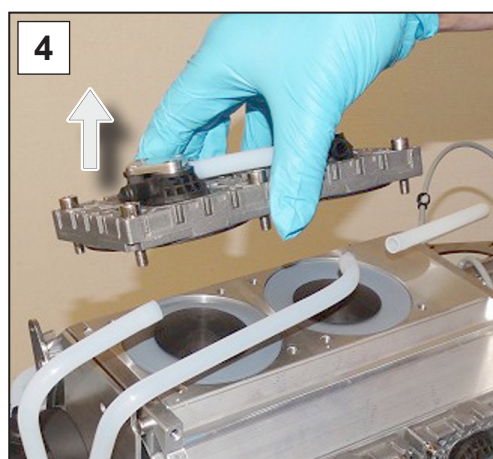

4. Remove the pump head pair with the screw fittings.

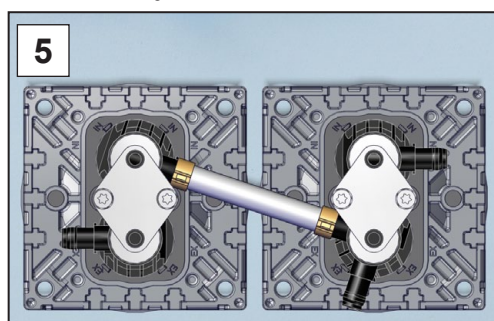

5. Set the pump head pair aside.

Replace the diaphragms

→ Example
Diaphragm
replacement

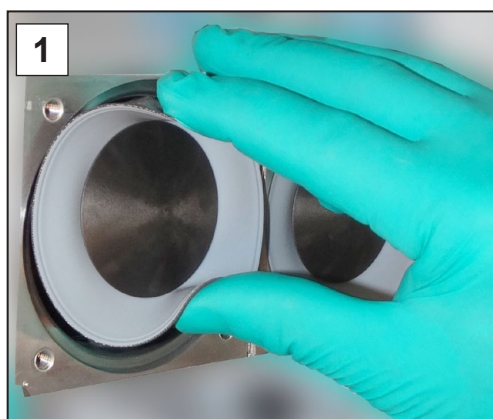

1. Lift the diaphragm upwards on either side.

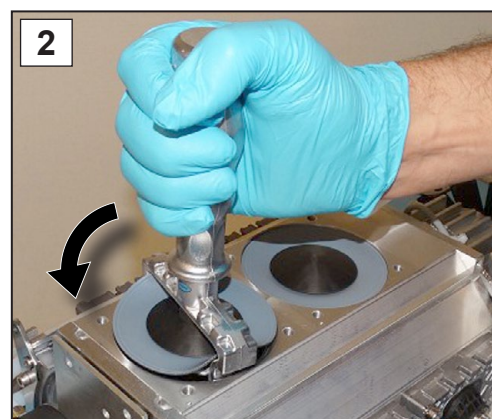

2. Carefully position the diaphragm wrench on the diaphragm support disc and unscrew the assembly with the diaphragm wrench attached.



3. Lift the diaphragm, along with all the parts, out of the vacuum pump.

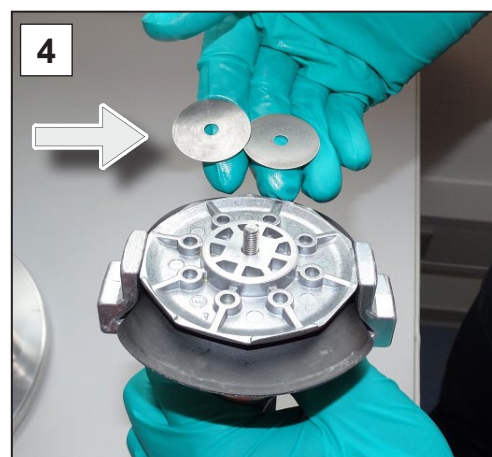

4. If the spacer discs adhere to the connecting rod, remove them carefully.

IMPORTANT!

- ⇒ Never drop spacer discs into the aluminum housing.
- ⇒ Keep the spacer discs. It is essential to reinsert the same number of spacer discs.

→ Example
Diaphragm
replacement

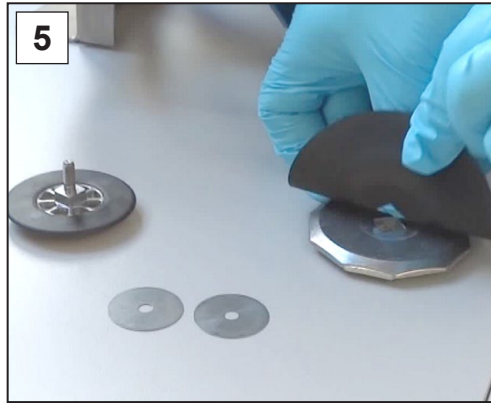

5. Pull out the diaphragm clamping disc and remove the used diaphragm.



6. Place the new diaphragm over the square head of the clamping disc.

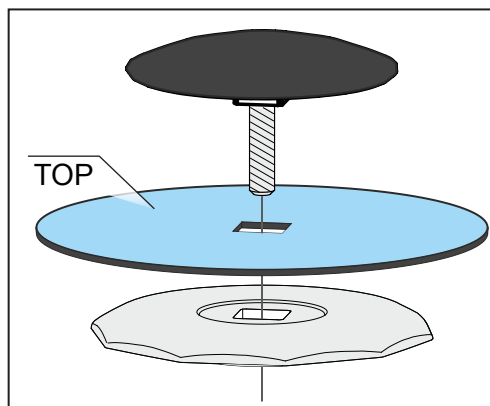

IMPORTANT!

- ⇒ Ensure that the diaphragm is inserted correctly, with the coated, light-colored side facing upwards.
- ⇒ Pay special attention to correct positioning on the square head.



7. Place all spacer discs on the thread pin.



8. Secure the diaphragm assembly inside the diaphragm wrench.

→ Example
Diaphragm
replacement



9. Hold the spacer discs firmly and place all the components carefully on the connecting rod thread.



10. Initially tighten the assembly with the diaphragm wrench by hand.

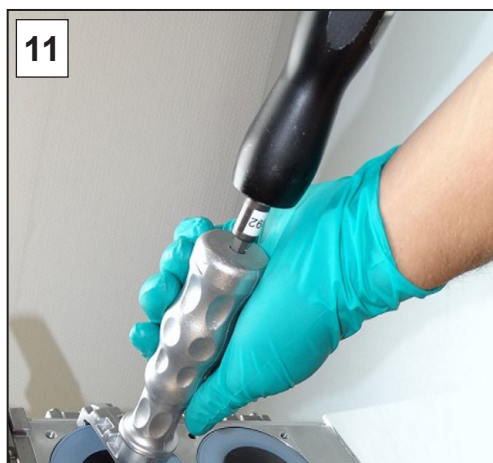

11. Then position a torque wrench with socket head bit on the diaphragm wrench and tighten the assembly to 6 Nm.

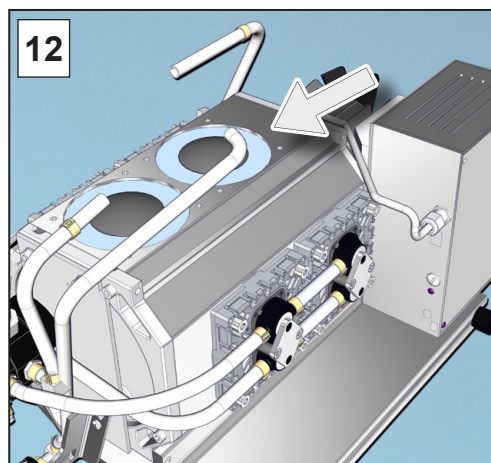

12. Repeat steps 1-11 for changing the next diaphragm.

→ Example
Valve replacement

Replace the valves

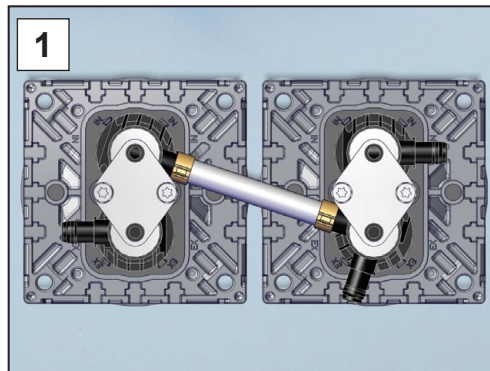

1. Take the pump head pair which you had set aside.

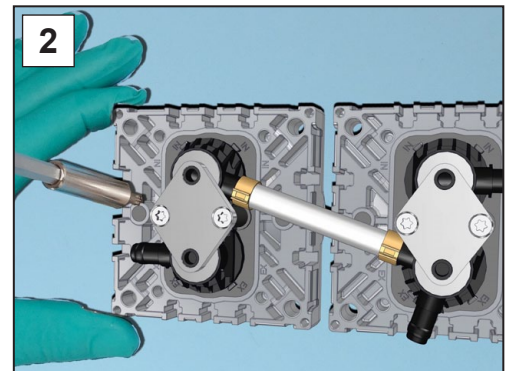

2. Unscrew the Torx screws. Torx screwdriver, size Tx20.

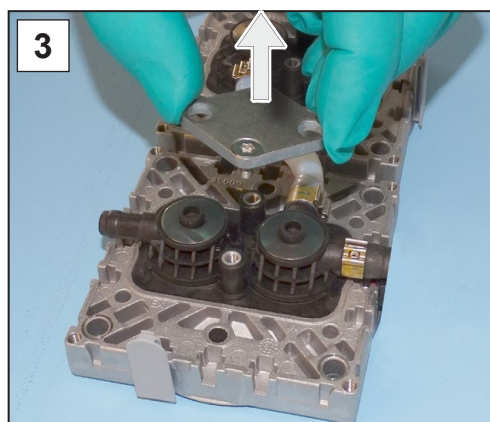

3. Remove the clamping claws from the valve terminals.

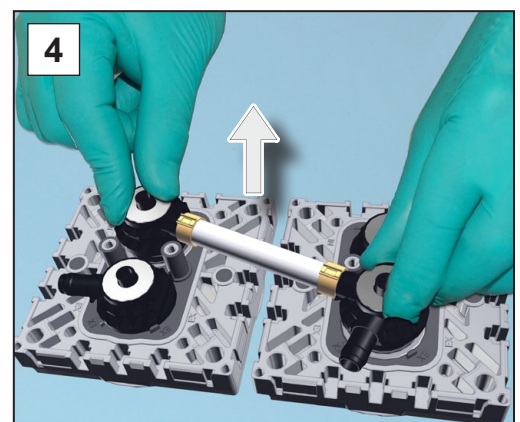

4. Remove the valve terminals with the disc springs.

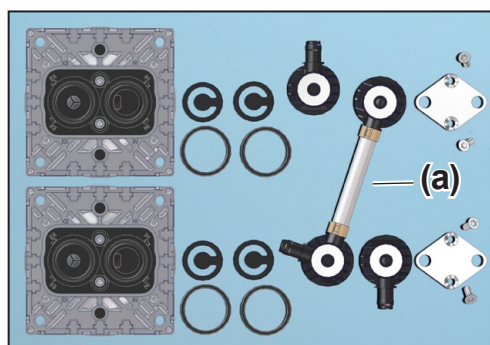

Example – view from above:
Valve terminals, valves, O-rings,
molded hose of a pump head pair.

NOTE

- ⇒ The number and wiring of molded hoses **(a)** depends on the position of the pump head pair. Pump head pairs must not be interchanged.
- ⇒ Valves can adhere to the underside of a valve terminal.
- ⇒ Depending on the pump type, the valve material is either PTFE (white) or FFKM (black).

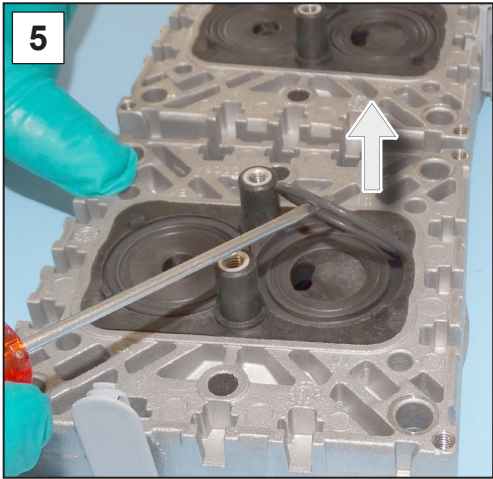

5. Carefully remove the used O-rings and valves.

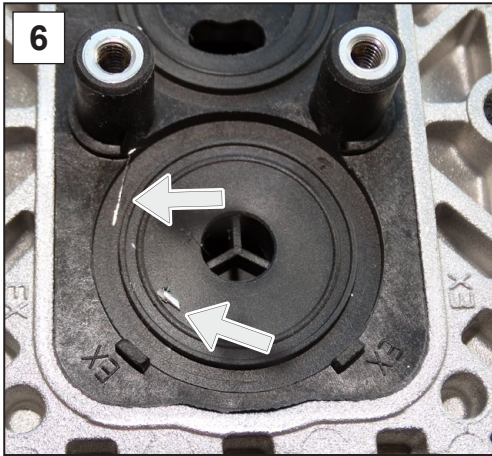

6. Check the surfaces for dirt.

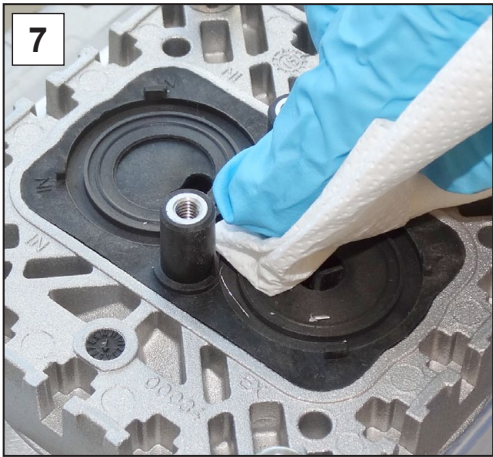

7. Clean dirty surfaces carefully.

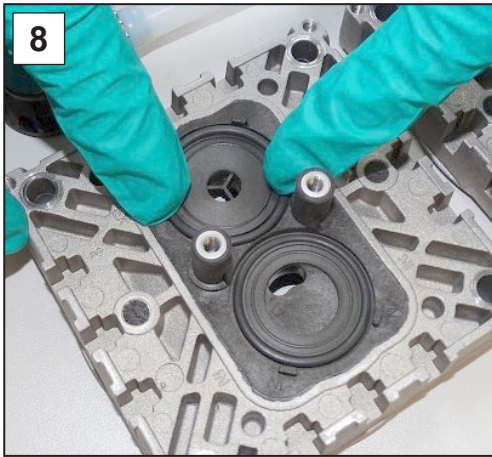

8. Insert the new sealing rings into the grooves.

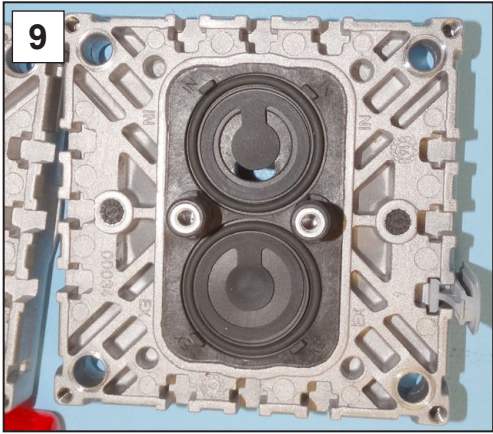

9. Place the new valves on top and align them.

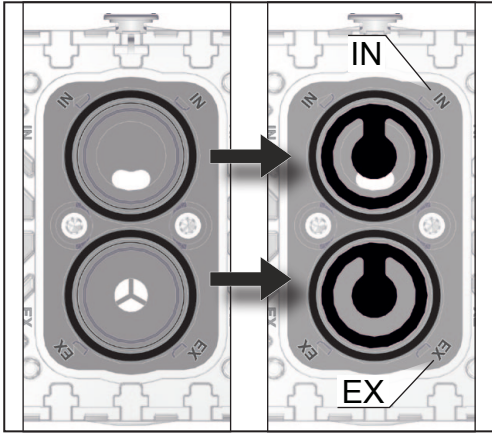

Cutout view from above: correct valve positioning. IN = inlet
EX = exhaust (outlet)

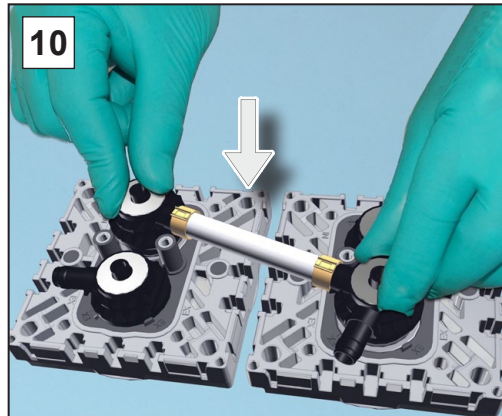

10. Place both valve terminals with the disc springs on the pump heads.

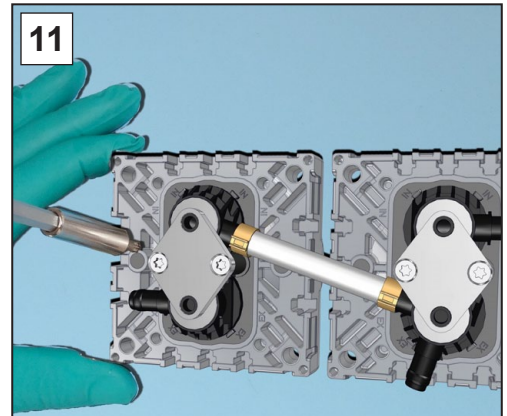

11. Place the clamping claws on the valve terminals and tighten the screw fittings first by hand, then with a torque wrench to 3 Nm.



12. Carefully press the diaphragms centrally into the housing opening, ensuring they are flush with it.

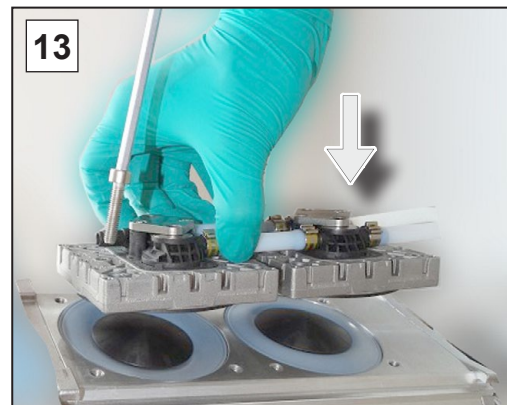

13. Hold the pump head pair at the vacuum pump and wind in the screw fittings; hex key size 5.

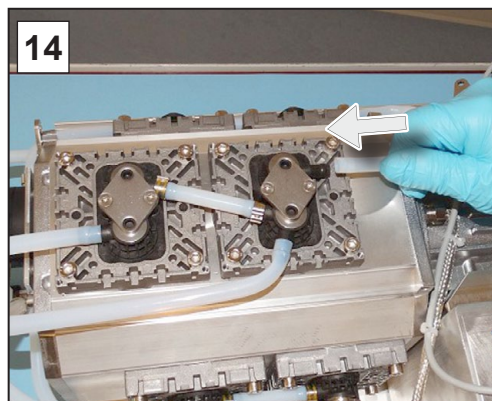

14. Slide the molded hoses back onto the hose nozzles.

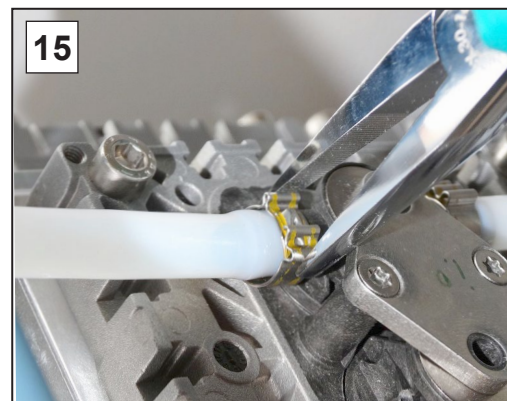

15. Secure the hose clips on the hose nozzles, e. g., with flat nose pliers.

Bottom pump head pair

Service the bottom pump head pair

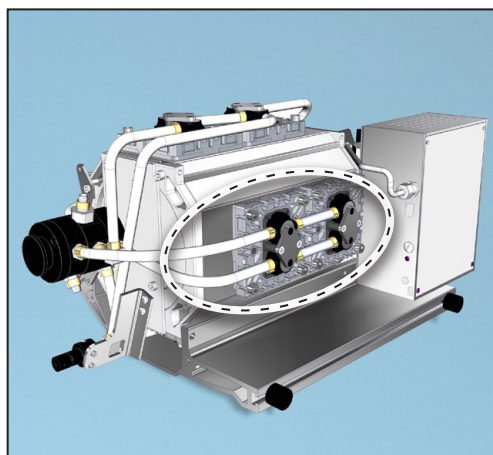

⇒ Follow the same procedure to change the diaphragms and valves as for the *Right pump head pair*, on pages 62 to 68 .

Left and top pump head pair

Service the left and top pump head pair

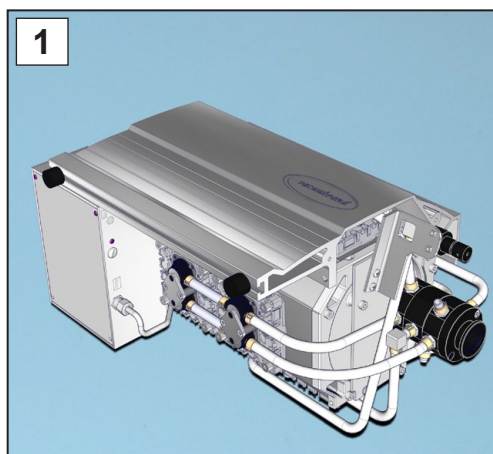

1. Turn the pump with the side panel upwards.

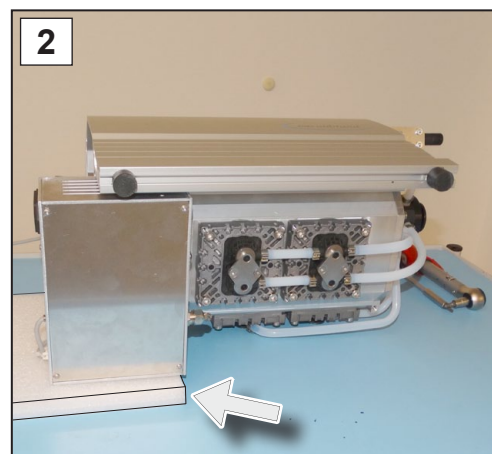

2. Support the pump, e. g., with rigid foam below the housing of the frequency converter.

Remove the left side panel

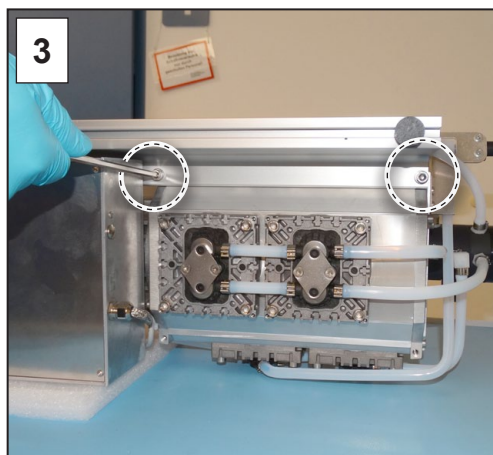

3. Unscrew the screw fittings from the side panel; hex key size 5.

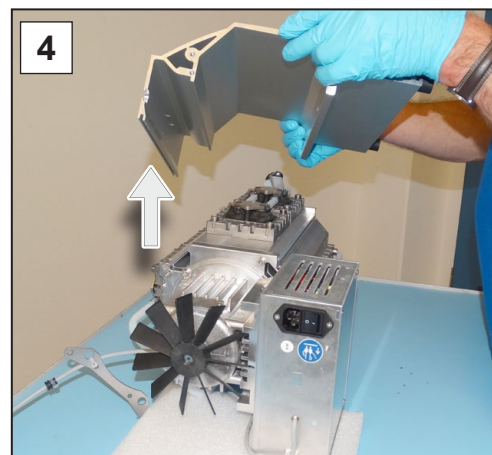

4. Lift the side panel off the pump.

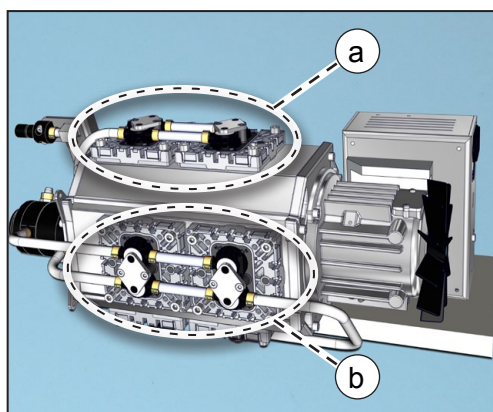

- a Left pump head pair
- b Top pump head pair

5. Follow the same procedure to change the diaphragms and valves as for the *Right pump head pair*, on pages 62 to 68 .

Assemble the device and housing sections

Before restarting the pump, all parts of the device and housing which had been removed must be fixed back in place.

Mount the side panel

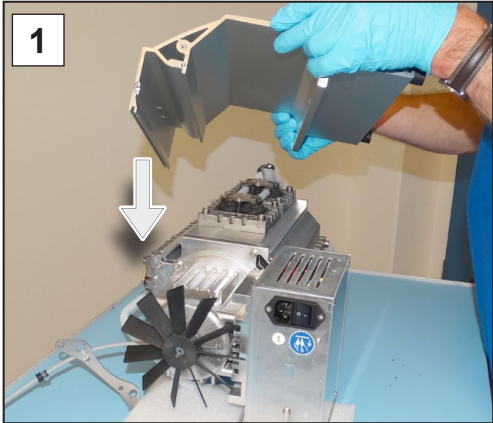

1. Replace the side panel on the pump.



2. Wind the screw fittings into the side panel; hex key size 5.

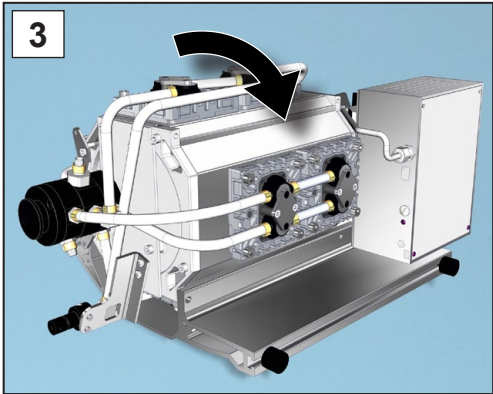

3. Turn the pump upwards and ensure it is positioned securely.

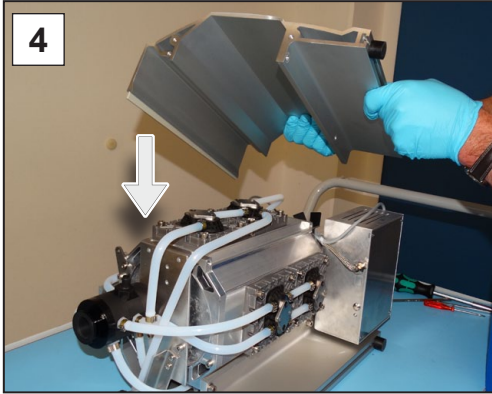

4. Replace the side panel on the pump.



5. Wind the screw fittings into the side panel; hex key size 5.

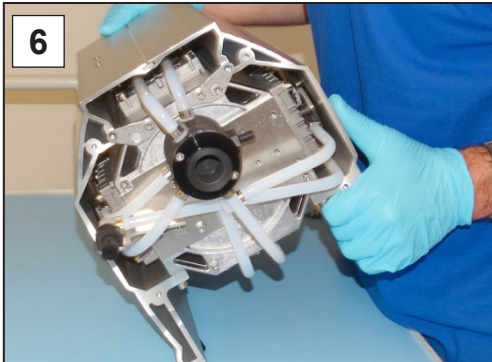

6. Stand the pump on its rubber feet.

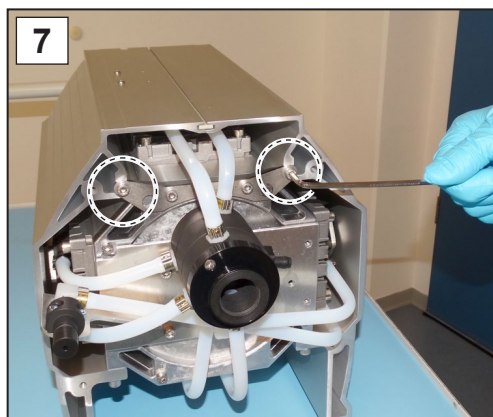

7. Wind in the 2 outer screws of the retaining plate; hex key size 4.

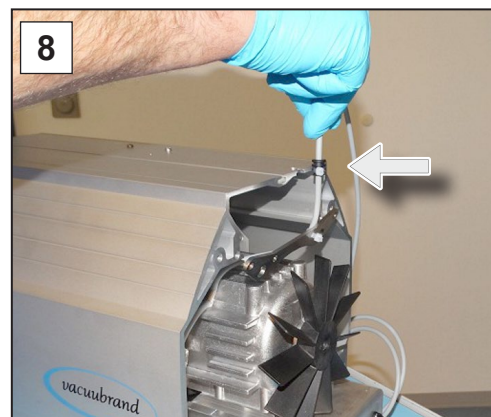

8. Secure the cable in the rear recess.

Assemble the rear housing section

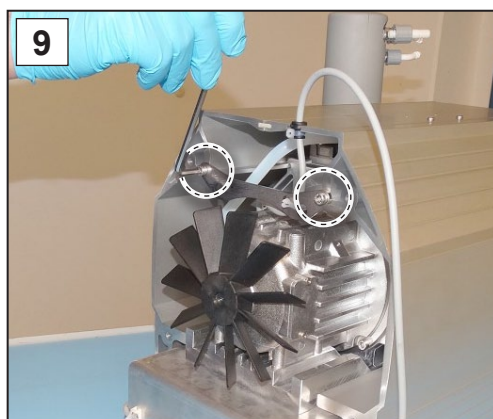

9. Wind in the screws of the side panel retaining plate; hex key size 4.

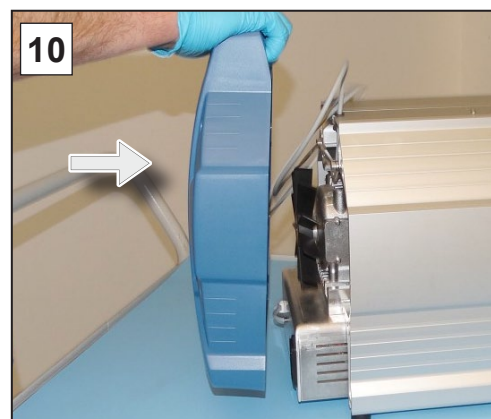

10. Replace the rear housing section.

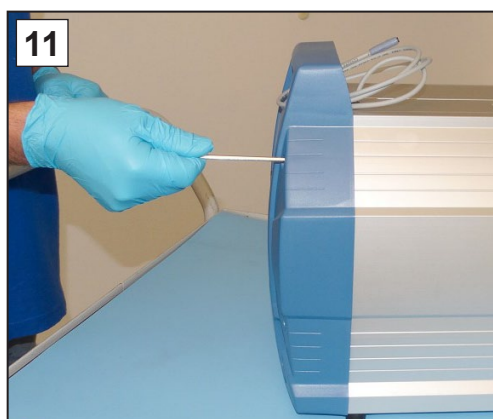

11. Wind in the screws of the housing section; hex key size 4.

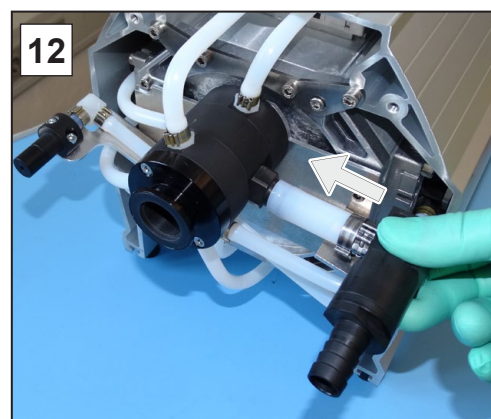

12. Attach the outlet holder, together with the hose, to the hose nozzle.

Assemble the outlet holder

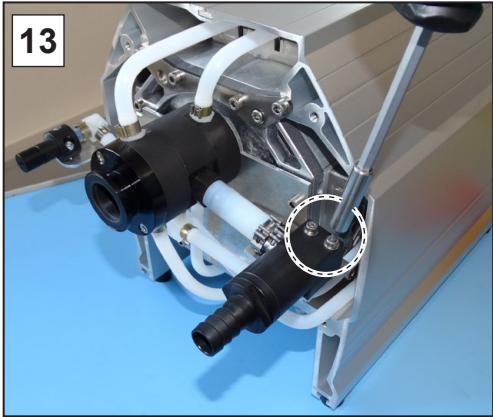

13. Wind in the 2 screws of the outlet holder; hex key size 3.

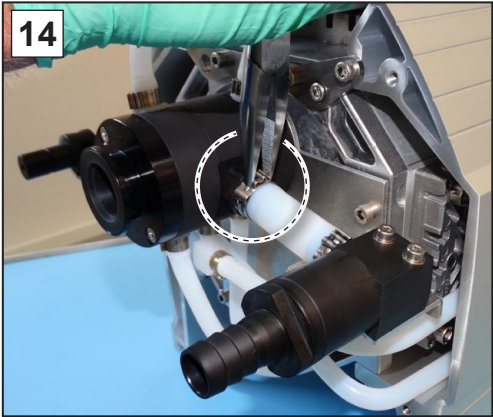

14. Secure the hose clip, e. g., with flat nose pliers.

Assemble the front housing section

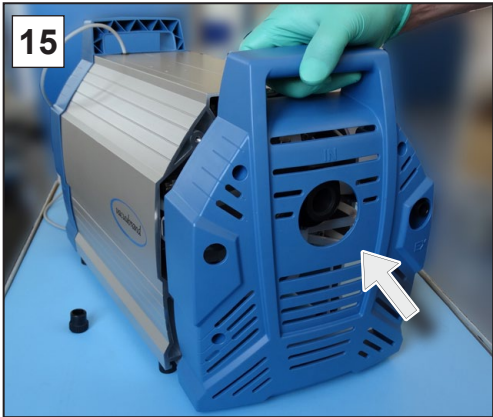

15. Replace the front housing section.

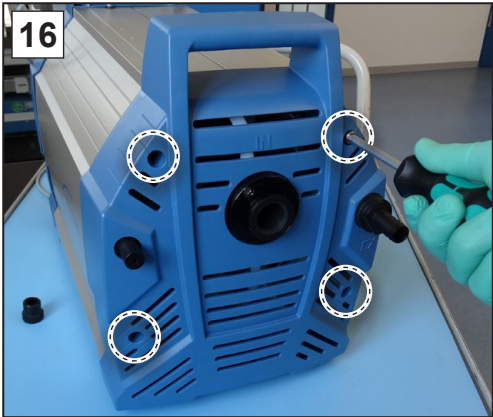

16. Wind in the screws of the housing section; hex key size 4.

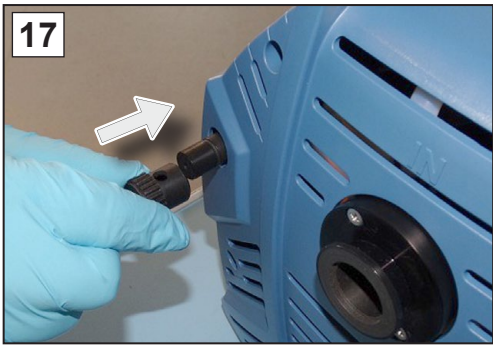

17. Place the cap on the gas ballast.



18. Secure the controller on the diaphragm pump and connect all cables.

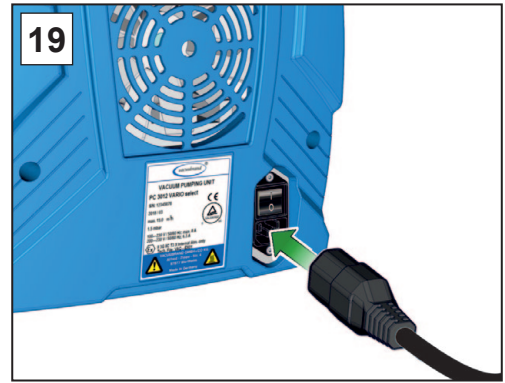

19. Plug in the power plug.

If maintenance work has been completed in full:

- ⇒ Connect the hoses for operation.
- ⇒ Connect the diaphragm pump to the power supply.
 - ☑ Diaphragm pump is ready to be returned to use.

If not reconnected:

- ☑ Diaphragm pump is ready for storage.

8 Appendix

8.1 Technical information

| | |
|--|----------------------------|
| Chemistry diaphragm pump series | |
| ME 16C VARIO select | MD 12C VARIO select |
| MV 10C VARIO select | |

8.1.1 Technical data

Technical data

| | | |
|-------------------------------|---------------------------|----------------------------|
| Ambient conditions | | (US) |
| Ambient temperature, max. | 10–40 °C | 50-104 °F |
| Working temperature | 10-40 °C | 50-104 °F |
| Storage/transport temperature | -10-60 °C | 14-140 °F |
| Max. altitude | 2000 m above sea level | 6562 ft above sea level |
| Relative humidity | 30-85 %, non-condensing | |
| Protection class | IP 40 / IK 08 | |

| | | |
|---|--------------------------------------|--------|
| Operating conditions | | (US) |
| Maximum admissible media temperature (gas), non-explosive atmosphere: | | |
| Short term | 80 °C | 176 °F |
| Continuous operation | 40 °C | 104 °F |
| ATEX conformity | II 3/- G IIC T3 X internal atm. only | |
| Maximum admissible media temperature (gas),  atmosphere: | | |
| Short term | 40 °C | 104 °F |
| Continuous operation | 40 °C | 104 °F |

| | |
|---|--|
| Connections | |
| Vacuum, inlet | Small flange KF DN 25 |
| Gas ballast GB | Gas ballast valve, manual |
| Inert gas adapter – OPTION | Small flange GB NT KF DN 16 Hose nozzle GB NT DN 6/10 |
| Venting valve (venting with inert gas) – OPTION | Silicone rubber hose 3/6 |
| Exhaust gas, outlet EX | Hose nozzle DN 15 |
| Cold device plug | + power supply CEE, CH, CN, UK, IN, US |
| Plug-in connector | VACUU·BUS® |

Technical data

| Electrical data | | (US) |
|---|---|--------------|
| Nominal voltage | 200-230 VAC | 100-120 VAC |
| Nominal frequency | 50 Hz/ 60 Hz | 50 Hz/ 60 Hz |
| Nominal current | 6.3 A | 8 A |
| Power, max. | 1 kW | |
| Interface | VACUU·BUS® | |
| Power cable | 2 m | |
| Vacuum data | | (US) |
| ME 16C VARIO select | | |
| Max. pump rate | 20 m ³ /h | 11.8 cfm |
| Ultimate vacuum, abs. | 70 mbar | 53 Torr |
| Ultimate vacuum with GB, abs. | 100 mbar | 75 Torr |
| Number of cylinders/stages | 8/1 | |
| MD 12C VARIO select | | |
| Max. pump rate | 15 m ³ /h | 8.8 cfm |
| Ultimate vacuum, abs. | 1.5 mbar | 1.1 Torr |
| Ultimate vacuum with GB, abs. | 3 mbar | 2.2 Torr |
| Number of cylinders/stages | 8/3 | |
| MV 10C VARIO select | | |
| Max. pump rate | 13 m ³ /h | 7.7 cfm |
| Ultimate vacuum, abs. | 0.6 mbar | 0.45 Torr |
| Ultimate vacuum with GB, abs. | 1.2 mbar | 0.9 Torr |
| Number of cylinders/stages | 8/4 | |
| Max. Inlet pressure, abs. | 1.1 bar | 825 Torr |
| Max. Outlet pressure, abs. | 1.1 bar | 825 Torr |
| Max. Differential pressure, abs. | 1.1 bar | 825 Torr |
| Max. Max. pressure at gas connections, abs. | 1.2 bar | 900 Torr |
| Sensor | integrated | integrated |
| Measuring principle | Ceramic diaphragm (aluminum oxide), capacitive, gas type independent, absolute pressure | |
| Accuracy of measurement | ±1 mbar/hPa/Torr, ±1 digit (after adjustment, constant temperature) | |
| Upper measurement limit | 1080 mbar | 810 Torr |
| Lower measurement limit | 0.1 mbar | 0.1 Torr |
| Temperature coefficient | < 0.15 mbar/hPa/K | 0.11 Torr/K |

| Weights* and dimensions (l x w x h) | | | (US) |
|--|-----------------------------|--|--------------------------------|
| ME 16C VARIO select | 533 mm x 260 mm x 450 mm | | 21.0 in x 10.2 in x 17.7 in |
| Weight* | 25.5 kg | | 56.2 lb |
| MD 12C VARIO select | 533 mm x 260 mm x 450 mm | | 21.0 in x 10.2 in x 17.7 in |
| Weight* | 25.5 kg | | 56.2 lb |
| MV 10C VARIO select | 533 mm x 260 mm x 450 mm | | 21.0 in x 10.2 in x 17.7 in |
| Weight* | 25.5 kg | | 56.2 lb |

* without cable

| Other information | |
|---|---------------------|
| Sensor type | VACUU-SELECT Sensor |
| Controller | VACUU-SELECT |
| Sound pressure level at 1500 rpm/62% (VARIO) | 47 dBA |

8.1.2 Wetted materials

Wetted materials

| Component | Wetted materials |
|--|--------------------------------------|
| Pump | |
| Head cover | ETFE carbon fiber reinforced |
| Diaphragm clamping disc | ETFE carbon fiber reinforced |
| Diaphragms | PTFE |
| Valves MD 12C VARIO select / MV 10C VARIO select | FFKM |
| Valves ME 16C VARIO select | PTFE |
| O-rings | FKM |
| Valve terminals | ECTFE, carbon fiber reinforced |
| Hose fittings | ETFE/ECTFE |
| Gas ballast pipe | PTFE carbon fiber reinforced |
| Hoses | PTFE |
| Inlet | PP glass fiber reinforced |
| Suction/pressure distributor | PTFE carbon fiber reinforced |
| Hose fitting to outlet/outlet holder | PTFE carbon fiber reinforced |
| Outlet/hose nozzle | PP |
| VACUU-SELECT Sensor | |
| Vacuum sensor | Aluminum oxide ceramic, gold-coated |
| Measurement chamber | PPS |
| Small flange | PP |
| Sealing ring at the sensor | Chemically resistant fluoroelastomer |
| Hose nozzle | PP |
| Venting valve seal | FFKM |

8.1.3 Rating plate

Data on rating plate



 ⇒ In the event of an error, make a note of the type and serial number on the rating plate.

⇒ When contacting our Service Department, please provide the type and serial number from the rating plate. This will allow us to provide you with specific support and advice for your device.

Diaphragm pump rating plate, general

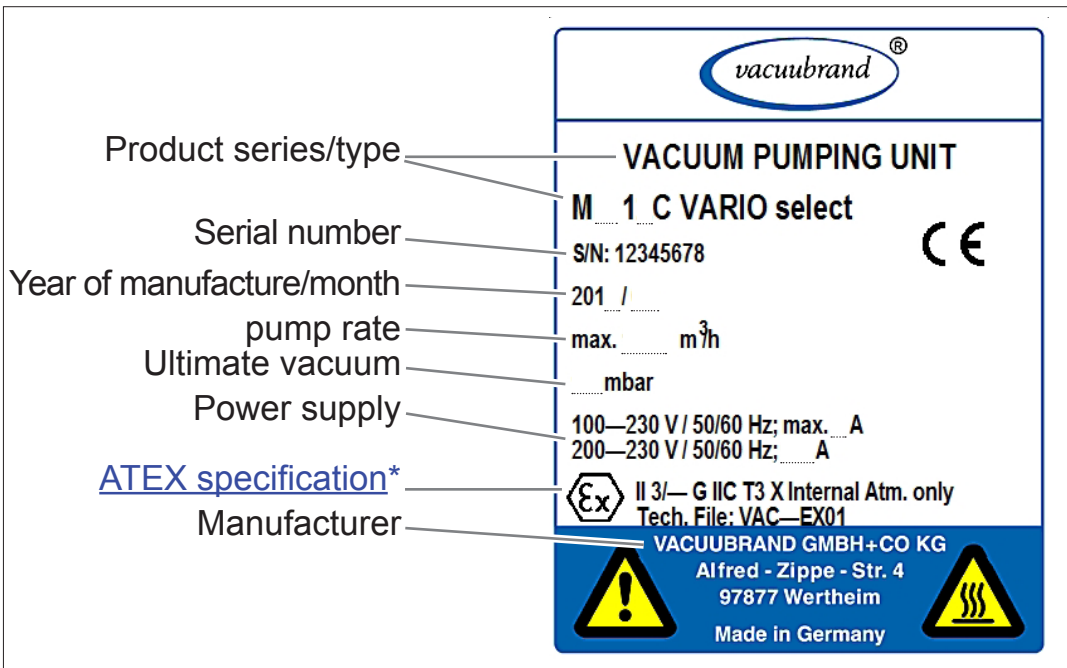
→ Example
Cut-out showing
rating plate

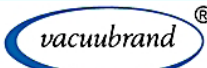

| | |
|----------------------------|---|
| |  |
| Product series/type | VACUUM PUMPING UNIT |
| Serial number | M 1 C VARIO select |
| Year of manufacture/month | S/N: 12345678 CE |
| pump rate | 201 / |
| Ultimate vacuum | max. _____ m ³ /h |
| Power supply | _____ mbar |
| <u>ATEX specification*</u> | 100—230 V / 50/60 Hz; max. _____ A 200—230 V / 50/60 Hz; _____ A |
| Manufacturer |  II 3/— G IIC T3 X Internal Atm. only Tech. File: VAC—EX01 |
| | VACUUBRAND GMBH+CO KG Alfred - Zippe - Str. 4 97877 Wertheim Made in Germany |

* Indicating documentation, group and category, marking G (gas), type of protection, explosion group, temperature class (see also: [Approval for ATEX equipment category](#)).

8.2 Ordering information

Ordering information
for pump series

| Diaphragm pump series | Order no.* |
|------------------------------|------------|
| ME 16C VARIO select | 207417xx |
| MD 12C VARIO select | 207437xx |
| MV 10C VARIO select | 207447xx |

* Order no. depends on power cable CEE, CH, UK, US, CN, IN

Ordering information
for accessories

| Accessories | Order no. |
|--|-----------|
| Vapor condenser expansion kit | 20699948 |
| Separator flask AK | 20699979 |
| PTFE hose KF DN 25 (l = 1000 mm) | 20686033 |
| Centering and sealing ring KF DN 25 C Al/FEP | 20635722 |
| Hose (rubber), d, 15 mm (length to order) | 20686003 |
| Stainless steel hose KF DN 25 (l = 1000 mm) | 20673337 |
| Coolant valve VKW-B | 20674220 |
| Venting valve VBM-B | 20674217 |
| Vacuum valve VS 25C, KF DN 25 | 20665008 |
| VACUU·SELECT Sensor with venting valve | 20700020 |
| Pressure sensor VSK 3000 | 20640530 |
| Hose nozzle KF DN 25/SW 15 | 20662808 |
| Threaded flange KF DN 16 / 1/2" | 20672101 |
| Adapter KF DN 25 to 2x PTFE pipes DN 10/8 | 20667052 |
| Silencer* G 1/2" | 20642473 |
| VACUU·BUS Y adapter | 20636656 |
| Extension cable VACUU·BUS, 0.5 m | 20612875 |
| Extension cable VACUU·BUS, 2 m | 20612552 |
| Extension cable VACUU·BUS, 10 m | 22618493 |
| DAkkS calibration with first delivery | 20900214 |
| DAkkS recalibration | 20900215 |

* Caution: Gases containing dust, deposits and condensed solvent vapors can affect the flow of gas through the silencer. These factors or a high gas flow rate can cause excess pressure to build up, which can damage the pump bearings, diaphragms, and valves. Do not use the silencer in such circumstances.

Ordering information
for spare parts

| Spare parts | | Order no. |
|--|-----|-----------|
| Anti-rotation protection D17x17.5 | | 20635113 |
| Gas ballast cap | | 20639223 |
| Service kit MD 12C / MV 10C VARIO select | | 20696839 |
| Service kit ME 16C VARIO select, 2x | | 20696867 |
| Power cable | CEE | 20612058 |
| | CH | 20676021 |
| | CN | 20635997 |
| | IND | 20635365 |
| | UK | 20612065 |



⇒ A full list of spare parts available can be found under
→ VACUUBRAND > Support > Instructions for repair >
[Chemistry diaphragm pumps](#).

Sources of supply

International
sales offices and
distribution

Purchase original accessories and original spare parts from a subsidiary of **VACUUBRAND GMBH + CO KG** or your local distributor.



⇒ Information about our complete product range is available in the current [product catalog](#).
⇒ Your local distributor or **VACUUBRAND GMBH + CO KG** [sales office](#) is available to assist you with orders, questions on vacuum control and optimal accessories.

8.3 Service

Service offer and
service range

Take advantage of the comprehensive range of services available from
VACUUBRAND GMBH + CO KG.



Services in detail

- Product consultation and practical solutions
- Fast delivery of spare parts and accessories
- Professional maintenance
- Immediate repairs processing
- On-site service (on request)
- Calibration (DAkkS-accredited)
- With Health and Safety Clearance form: return, disposal.

⇒ Visit our website for further information: www.vacuubrand.com.

Service handling

Meet the
terms of service

1. Contact your local distributor or our Service Department.
2. Request an RMA no. for your order.
3. Clean the product thoroughly or if necessary, decontaminate it professionally.
4. Fill out the Health and Safety Clearance form in full.
5. Return your product, including:
 - RMA no. and description of the error
 - Repair or service order
 - Health and Safety Clearance form
 - Attach everything to the outside of the package

Return (reshipment)



⇒ Reduce downtime, speed up processing. Please have the required data and documents at hand when contacting our Service Department.

- ▶ Your order can be quickly and easily processed.
- ▶ Hazards can be prevented.
- ▶ A brief description and/or photos will help locate the source of the error.

8.4 Index

Index

| | |
|---|--|
| A | L |
| Abbreviations 9 | Labels and signs 20 |
| Accessories 80 | Limitation of use 29 |
| Action steps 9 | Local area vacuum network 25 |
| Additional symbols 8 | M |
| Assemble the front housing section 73 | Maintain minimum distance 19 |
| Assemble the outlet holder 73 | Maintenance 49 |
| Assemble the rear housing section 72 | Maintenance intervals 50 |
| ATEX equipment category 21 | Mandatory sign 8 |
| ATEX equipment labeling 21 | Manual structure 6 |
| B | Measurement chamber 78 |
| Blockage protection 20 | Minimum distances 29 |
| C | Mount the base (option) 30 |
| Clean the surfaces 52 | Mount the side panel 71 |
| Connect venting valve 34 | O |
| Copyright © 5 | Operate gas ballast valve 42 |
| D | Operating elements |
| Disassemble the device and housing 54 | Vacuum controller 40 |
| sections 54 | Operating hours until maintenance 50 |
| Disassemble the front housing section 54 | Operating panel 10 |
| Disassemble the housing sections . 55 | Operation with gas ballast 42 |
| Display conventions 7 | Operator obligations 13 |
| Display of operating steps 9 | Ordering information 80 |
| Disposal 22 | Ordering information for pump series . 80 |
| Distributors 81 | Outlet 67 |
| E | Overheating 19 |
| EC Declaration of Conformity 85 | Overheating protection 20 |
| Electrical connection 36 | P |
| Eliminate sources of danger 17 | Peripheral devices and ATEX 21 |
| Error – Cause – Remedy . . . 45, 46, 47 | Personnel obligations 13 |
| Examples of use 25 | Personnel qualification 14 |
| EX = exhaust 67 | Power cable 36 |
| Exhaust gas connection 33 | Pressure relief valve 56 |
| Explanation of safety symbols 8 | Pressure relief valve + O-ring maintenance 56 |
| Exploded drawing of suction/pressure distributor 57 | Prevent blockages in the outlet line 17 |
| F | Prevent condensate return 17 |
| Foreseeable misuse 12, 13 | Prevent ignition sources 21 |
| G | Process screen (main screen) 40 |
| Goods receipt 27 | Product-specific terms 10 |
| H | Prohibition sign 8 |
| Handling instructions 9 | Protective clothing 15 |
| Hazards when venting 18 | Pump electrical connection 36 |
| Hot surfaces 19 | Q |
| I | Qualification description 14 |
| Icons 8 | Quality standard 15 |
| Improper use 12 | R |
| Incorrect measurements 17 | Rating plate 79 |
| IN = inlet 67 | Recommended aids for cleaning and maintenance 50 |
| Inlet 67 | Remove the left side panel 70 |
| Instruction modules 6 | Remove the right side panel 60 |
| Intended use 11 | Replace pressure relief valve + O-ring 57 |
| | Reset thermal fault 46 |

| | | |
|----------|--|--------|
| Index | Residual energy | 18 |
| | Responsibility matrix | 14 |
| | Return (reshipment) | 82 |
| | Return to use after maintenance . . . | 74 |
| S | | |
| | Safety information | 11 |
| | Safety information for vacuum equip- ment | 11 |
| | Safety precautions | 15 |
| | Service handling | 82 |
| | service range | 82 |
| | Service the bottom pump head pair | 69 |
| | Service the left and top pump head pair | 69 |
| | Sources of supply | 81 |
| | Spare parts | 81 |
| | Start | 41 |
| | Stop | 41 |
| | Storage, prepared | 74 |
| | Switch pump off | 43 |
| | Switch pump on | 39 |
| | Symbols | 8 |
| T | | |
| | Target groups | 14 |
| | Technical data | 75, 76 |
| | Technical information | 75 |
| | Technical support | 45 |
| | Term definitions | 10 |
| U | | |
| | Unpacking | 27 |
| | User information | 5 |
| V | | |
| | VACUU·BUS® | 10 |
| | VACUU·BUS® connector | 10 |
| | Vacuum connection | 32 |
| | Vacuum controller operation | 39 |
| | Valve replacement | 65, 66 |
| | Valves, pump head | 61 |
| | venting | 41 |
| | Vent with inert gas | 34 |
| W | | |
| | Warning symbol | 8 |
| | Wetted materials | 78 |

8.5 EU Declaration of Conformity

EU-Konformitätserklärung EC Declaration of Conformity Déclaration CE de conformité



Hersteller / Manufacturer / Fabricant:

VACUUBRAND GMBH + CO KG · Alfred-Zippe-Str. 4 · 97877 Wertheim · Germany

Hiermit erklärt der Hersteller, dass das Gerät konform ist mit den Bestimmungen der Richtlinien:

Hereby the manufacturer declares that the device is in conformity with the directives:

Par la présente, le fabricant déclare, que le dispositif est conforme aux directives:

2006/42/EG (M-RL), 2014/30/EU (EMV-RL), 2014/34/EU (ATEX-RL),
2011/65/EU (RoHS-2)

Chemie-Membranpumpen / Chemistry diaphragm pumps / Pompes à membrane *chimie*

Typ / Type / Type: **ME 16C VARIO select, MD 12C VARIO select,
MV 10C VARIO select**

Artikelnummer / Order number / Numéro d'article: **20741750, 20743750,
20744750**

Seriennummer / Serial number / Numéro de série: Siehe Typenschild / See rating plate / Voir plaque signalétique

Angewandte harmonisierte Normen / Harmonized standards applied / Normes harmonisées utilisées: DIN EN ISO 12100:2011, DIN EN 1012-2:2011, IEC 61010-1:2010 (Ed. 3), DIN EN 61010-1:2011, DIN EN 61326-1:2013, DIN EN 1127-1:2011, DIN EN ISO 80079-36:2016, DIN EN 50581:2013

Bevollmächtigter für die Zusammenstellung der technischen Unterlagen / Person authorised to compile the technical file / Personne autorisée à constituer le dossier technique: Dr. J. Dirscherl · VACUUBRAND GMBH + CO KG · Germany

Ort, Datum / place, date / lieu, date: Wertheim, 13.06.2018

(Dr. F. Gitmans)

*Geschäftsführer / Managing Director /
Gérant*

ppa.

(Dr. J. Dirscherl)

*Technischer Leiter / Technical
Director / Directeur technique*

VACUUBRAND GMBH + CO KG

Alfred-Zippe-Str. 4
97877 Wertheim

Tel.: +49 9342 808-0

Fax: +49 9342 808-5555

E-Mail: info@vacuubrand.com

Web: www.vacuubrand.com



Technology for Vacuum Systems

Manufacturer:

VACUUBRAND GMBH + CO KG
Alfred-Zippe-Str. 4
97877 Wertheim
GERMANY

Phone:

- Head office +49 9342 808-0
- Sales +49 9342 808-5550
- Service +49 9342 808-5660

Fax: +49 9342 808-5555

Email: info@vacuubrand.com

Web: www.vacuubrand.com