



Vacuubrand ME-16CNT

Technical Specifications

		ME 16C NT
Number of heads / stages		8 / 1
Max. pumping speed at 50/60 Hz	m ³ /h	16.3 / 18.4
Max. pumping speed at 50/60 Hz	cfm	9.6 / 10.8
Ultimate vacuum (abs.)	mbar/torr	70 / 53
Ultim. vac. (abs.) with gas ballast	mbar/torr	100 / 75
Ambient temperature range (operation)	°C	10 - 40
Ambient temperature range (storage)	°C	-10 - 60
Max. back pressure (abs.)	bar	1.1
Inlet connection		small flange KF DN 25
Outlet connection		Hose nozzle DN 15 mm
Rated motor power	kW	0.44
Rated motor speed at 50/60 Hz	min ⁻¹	1500/1800
Protection class		IP 40
Dimensions (L x W x H)	mm	533 x 260 x 359
Weight	kg	28.1
Noise level at 50 Hz, typ.	dBA	52
ATEX conformity (only 230V)		II 3/- G IIC T3 X Internal Atm. only
Items supplied		Pump completely mounted, ready for use, with manual.
Accessories		PTFE tubing KF DN 25 (1000 mm: 20686033) Inlet separator KF DN 25 (20699979) Centering and sealing ring KF DN 25 C AI/FEP (20635722) Emission condenser kit for NT pump models (20699948)



PROVAC

SALES

PHONE: 831-462-8900

FAX: 831-462-3536

WWW.PROVAC.COM

Vacuubrand ME-16CNT Pumping Curves

50Hz

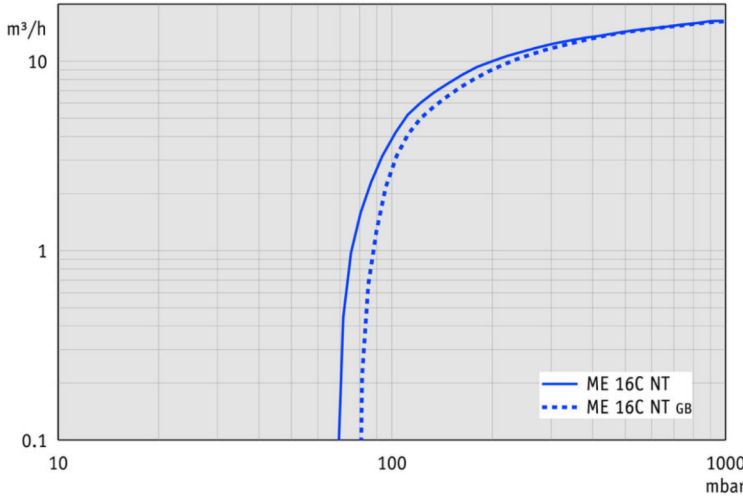

60Hz

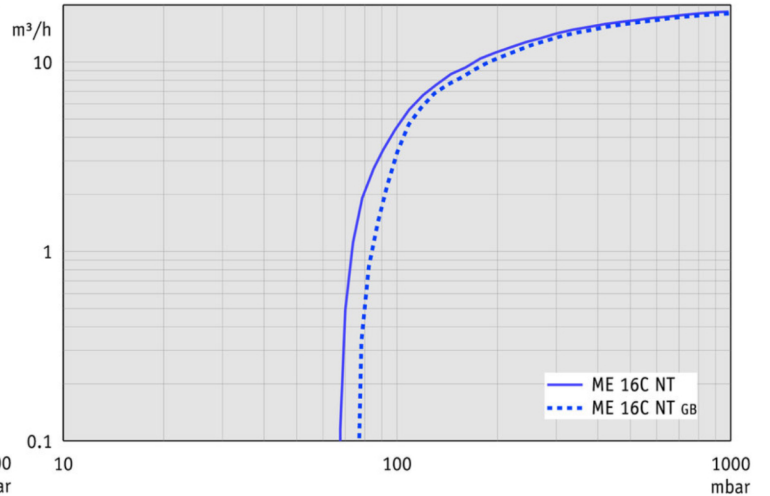

Dimensions

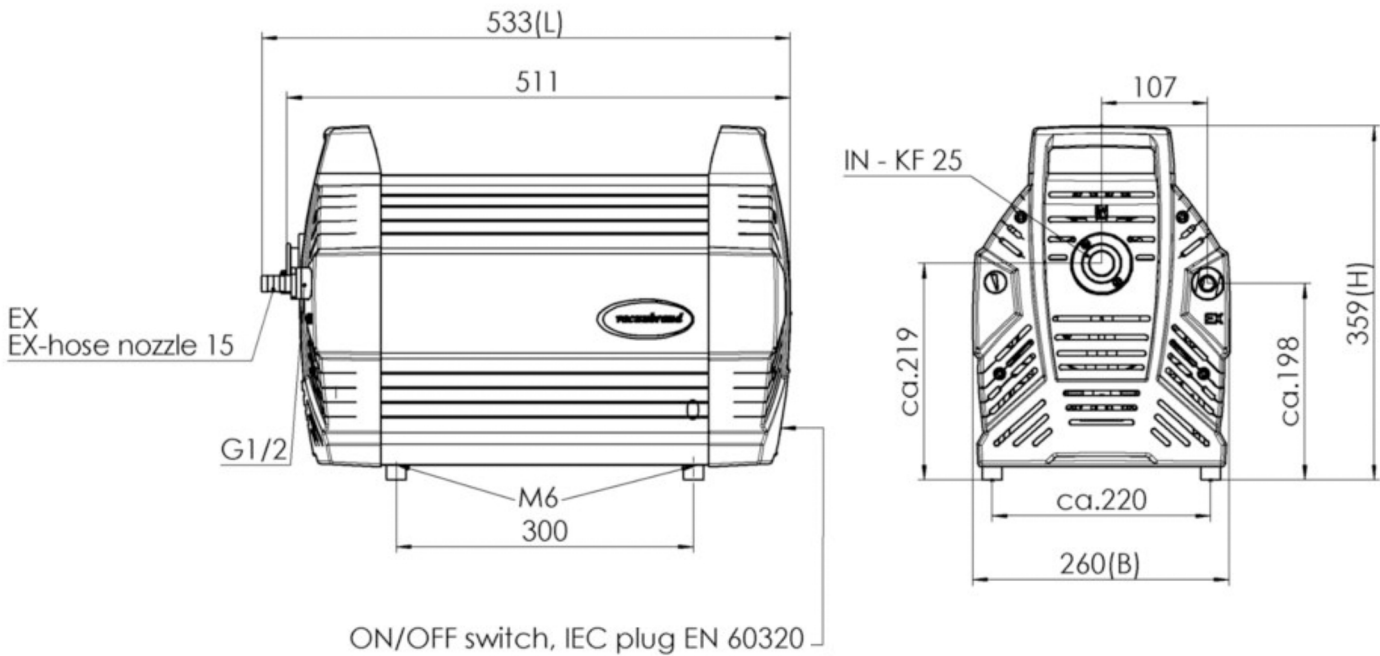

weight 28,1 kg
all dimensions (mm)

VACUUBRAND ME 16C NT, MD 12C NT, MV 10C NT
Version 2012/04/20



PROVAC

SALES

PHONE: 831-462-8900

FAX: 831-462-3536

WWW.PROVAC.COM

Vacuubrand ME-16CNT Features & Benefits

- excellent solution for continuous, oil-free pumping of corrosive gases & vapors
- advantageous combination of high pumping speed & low ultimate vacuum
- eight-cylinder pump provides particularly high performance together with a compact design
- outstanding chemical resistance & superior vapor tolerance
- whisper quiet & very low vibration operation
- long diaphragm life
- maintenance free drive system

Applications

- drying chambers • filtration & solid phase extraction • local area vacuum networks for laboratories

