

Vacuum Pumps

Instrumentation

Fittings and Valves



LEYBOLD VACUUM

GA 10.204 / 3.02



ULTRATEST UL 500

Helium Leak Detector

Cat. No.
155 85

Operating Instructions

LEYBOLD-Service

If an appliance is returned to LEYBOLD VACUUM GmbH, indicate whether the appliance is free of substances damaging to health or whether it is contaminated. If it is contaminated also indicate the nature of the hazard. LEYBOLD must return any appliance without a declaration of contamination to the sender's address.

General Note

The right of alterations in the design and the technical data is reserved.

The illustrations are not binding.

Contents

| | Page | | Page |
|----------|----------------------------------|----------|--|
| 1 | Description | | |
| 1.1 | General | 2.2.2.1 | Vacuum Mode |
| 1.1.1 | Unpacking | 2.2.2.2 | „SNIFF“ Mode |
| 1.1.2 | Transport at the Customer's Site | 2.2.3 | „INSP / MEAS“ Key |
| 1.1.3 | Purpose | 2.2.3.1 | „INSPECT“ Mode |
| 1.1.4 | Modules | 2.2.3.2 | „MEASURE“ Mode |
| 1.2 | Technical Data | 2.2.4 | „START / RESET MAX“ Key |
| 1.2.1 | Physical Data | 2.2.4.1 | „START / RESET MAX“ Key in STANDBY |
| 1.2.2 | Electrical Data | 2.2.4.2 | „START / RESET MAX“ Key in DETECT Mode |
| 1.3 | Technical Description | 2.2.5 | „STOP/VENT“ Key |
| 1.3.1 | Principle of Leak Detection | 2.2.5.1 | „STOP“ Function |
| 1.3.2 | Double-Entry Turbomolecular Pump | 2.2.5.2 | „VENT“ Function |
| 1.3.3 | Forepump | 2.2.6 | „ZERO“ Key |
| 1.3.4 | Auxiliary Pump | 2.2.7 | „CAL“ Key |
| 1.3.5 | Mass Spectrometer | 2.2.8 | „RATE / CONC“ Key |
| 1.3.5.1 | Ion Source | 2.2.9 | „PREC“ Key |
| 1.3.5.2 | Separation System | 2.2.10 | „MAX / ACT“ Key |
| 1.3.5.3 | Ion Collector | 2.2.10.1 | „MAXIMUM“ Function |
| 1.3.6 | Electronics Modules | 2.2.10.2 | „ACTUAL“ Function |
| 1.3.6.1 | Electrometer Amplifier | 2.2.11 | „FAST / SLOW“ Key |
| 1.3.6.2 | Mass Spectrometer Supply Unit | 2.2.12 | „Numeric Keypad“ |
| 1.3.6.3 | Turbomolecular Pump Supply Unit | 2.2.13 | „Decimal Point“ Key (.) |
| 1.3.6.4 | Power Distribution Unit | 2.2.14 | „EXP“ Key |
| 1.3.6.5 | Power Conversion Unit | 2.2.15 | „PLUS / MINUS“ Key (+/-) |
| 1.3.6.6 | Control Unit | 2.2.16 | „Arrow LEFT / RIGHT“ Keys |
| 1.3.6.7 | Keypad and Display Unit | 2.2.17 | „CLR“ Key |
| 1.4 | Equipment | 2.2.18 | „LIMIT LOW / LIMIT HIGH“ Key |
| 1.4.1 | Standard Specification | 2.2.18.1 | Operation with only „LIMIT LOW“ Activated |
| 1.4.2 | Accessories | 2.2.18.2 | Operation with „LIMIT LOW“ and „LIMIT HIGH“ Activated |
| 2 | Operation | 2.2.18.3 | Manual Ranging in Connection with set Upper and Lower Limit |
| 2.1 | Installation of UL 500 | 2.2.19 | „OPT“ Key |
| 2.1.1 | Layout of Controls and Displays | 2.2.20 | „HELP“ Key |
| 2.1.2 | Preparations for Initial Startup | 2.2.21 | „EXEC“ Key |
| 2.1.2.1 | Electrical Connections | | |
| 2.2 | Description of Controls | | |
| 2.2.1 | Power Switch | | |
| 2.2.2 | „SNIFF / VAC“ Key | | |

| | Page | | Page |
|----------|---|-----------|-------------|
| 2.2.22 | Volume Control | 24 | |
| 2.2.23 | Recorder Output and Remote Control Connection Socket | 25 | |
| 2.2.24 | Pin-out of the Multifunction Socket | 26 | |
| 2.2.25 | Headset Output | 26 | |
| 2.3 | Description of Displays | 27 | |
| 2.3.1 | Analog Display | 27 | |
| 2.3.1.1 | Analog Display in Conjunction with „LIMIT LOW / LIMIT HIGH“ Functions | 27 | |
| 2.3.2 | Digital Display | 27 | |
| 2.3.2.1 | Digital Display in Conjunction with „ACTUAL“ Function | 27 | |
| 2.3.2.2 | Digital Display in Conjunction with „MAXIMUM“ Function | 28 | |
| 2.3.3 | Limit Value Display (Low and High Limits) | 28 | |
| 2.3.4 | Status Displays | 28 | |
| 2.3.4.1 | Description of Status Displays | 28 | |
| 2.3.5 | Alphanumeric Display | 29 | |
| 2.3.6 | Acoustic Signal | 29 | |
| 2.4 | Startup (First Pumpdown Cycle) | 30 | |
| 2.5 | Operating Modes | 31 | |
| 2.5.1 | Vacuum Mode (VAC) | 31 | |
| 2.5.1.1 | Local Leak Detection in the Vacuum Mode | 31 | |
| 2.5.1.2 | Integral Leak Detection in the Vacuum Mode | 32 | |
| 2.5.2 | „SNIFF“ Mode | 33 | |
| 2.5.2.1 | Local Leak Detection in SNIFF Mode | 33 | |
| 2.5.2.2 | Integral Leak Detection in SNIFF Mode | 33 | |
| 2.5.2.3 | Calculation of Standard Leak Rate as a Function of Pressure Differential | 34 | |
| 2.5.3 | „INSPECT“ Mode | 34 | |
| 2.5.4 | „MEASURE“ Mode | 34 | |
| 2.6 | Shutdown | 35 | |
| 2.7 | Calibration | 35 | |
| 2.7.1 | Calibration in Vacuum Mode | 35 | |
| 2.7.1.1 | Calibration with Internal Calibrated Leak | 35 | |
| 2.7.1.2 | Calibration with External Calibrated Leak | 35 | |
| 2.7.2 | Calibration in SNIFF mode | 36 | |
| 2.7.2.1 | Calibration with a Known Helium Concentration | 36 | |
| 2.7.2.2 | Calibration of Helium Leak Rate | 36 | |
| 2.8 | Automatic Functions | 37 | |
| 2.8.1 | AUTOTUNE | 37 | |
| 2.8.2 | AUTOZERO | 37 | |
| 2.8.3 | AUTORANGE | 37 | |
| 3 | Maintenance | 39 | |
| 3.1 | Checking the Oil Level and Gas Ballast Switch of the Auxiliary Pump or Forepump | 39 | |
| 3.2 | Exchanging the Fluorescent Tube behind the Display | 39 | |
| 3.3 | Changing the Fuses on the Power Distribution (LV) Front Panel | 39 | |
| 3.4 | Exchanging the Filter Mat | 40 | |
| 3.5 | Draining Condensate from the Compressor Buffer Vessel | 41 | |
| | ANNEX 1 | 42 | |
| | Parameter entry mode (PARA MODE) | 42 | |
| | ANNEX 2 | 43 | |
| | Operation of the UL 500 on mass 2 and 3 (Hydrogen) | 43 | |
| | ANNEX 3 | 44 | |
| | Equipment messages; Messages for the operator on the text display | 44 | |
| | ANNEX 4 | 46 | |
| | Error messages | 46 | |

1 Description

1.1 General



These Operating Instructions contain important information on the functions, installation, operation, troubleshooting and maintenance of the ULTRATEST UL 500.

Before startup of the detector, please read Sections 1.1 and 1.4. For initial startup, follow Sections 2.1 and 2.4 to 2.6.

Important remarks concerning operational safety and protection are emphasized as follows:

Warning



Indicates procedures that must be strictly observed to prevent hazards to persons.

Caution

Indicates procedures that must be strictly observed to prevent damage to, or destruction of, the ULTRATEST UL 500 helium leak detector.

Note

Indicates special technical requirements that the user must comply with.

The references to diagrams, e.g. (2/5), consist of the Fig. No. and the Item No. in that order.

1.1.1 Unpacking

Unpack the helium leak detector immediately after delivery, even if it is to be put into operation at a later date.

Caution

Pull or push the instrument only at its housing and not at its display unit.

Examine the shipping container for any external damage and then completely remove the packaging materials.

Note

The shipping container and packaging materials must be kept in the event of complaints about damage.

Check that the ULTRATEST UL 500 is complete (Section 1.4) and carefully examine it visually.

Examine the display unit to ensure that no damage has occurred during shipment.

If any damage is discovered, report it immediately to the forwarding agent and insurer.

If the damaged part has to be replaced, please get in touch with the orders department.

1.1.2 Transport at the Customer's Site

For transport of the instrument pull or push it only at the housing and not at the display unit.

Special preparations are required for transportation of the UL 500 with a crane.

The set of crane eyes Ref. No. Nr. 200 59 475 contains an extended crane eye to prevent damage to the display unit through the steel wire. Further parts are included for stiffening of the frame:

Clamping pieces

to prevent the dislodging of the crane eyes from the aluminium profile.

Screws

to stiffen the bottom plate. From serial No. 018700090 and higher, the use of these screws it is not required.

Moreover it is recommended to use a transport frame so that the lifting forces are applied perpendicular to the work panel of the UL 500 and the profiles of the UL 500 are subjected only to pulling forces.

Caution

The **exclusive use** of standard crane eyes will result in damage to the display unit. The additional strengthening measures using the clamping pieces and screws must be introduced to prevent damage to the instrument.

1.1.3 Purpose

The ULTRATEST UL 500 helium leak detector is a helium leak indicator based on the mass-spectrometric principle of detection. It permits leak tests to be carried out on test objects of virtually all sizes and up to the largest volumes.

All equipment needed for leak detection is supplied with the UL 500.

1.1.4 Modules

The UL 500 comprises three main assemblies (see Fig.1) :

Operating level

- keypad (1/1)
- display unit (1/2)
- work panel (1/3)

Measurement and control level

- valve block (1/4)
- compressed air supply (1/5)
- high-vacuum plug-in (1/9)
- electronics plug-in (1/10)

- Pump level
- backing pump (1/6)
 - auxiliary pump (1/7)
 - mains transformer (1/8)
 - peripheral connections

- Response times
- up to test-object volumes of 10 l ≤ 1 s
 - up to test-object volumes of 50 l ≤ 5 s
 - permissible temperature range 10 to 40 °C

Display capabilities for leak rate:
 Quasi-analog display for leak rate:
 360 ° circular indicator, with logarithmic scale,
 1 decade per revolution,
 45 segments correspond to 5 %
 resolution of indicated value

Bar scale for leak rate exponent
 exponent display from -10 to +3

Digital display for leak rate 2 digits,
 2-digit exponent, sign

Units displayed ppm
 mbar·l·s⁻¹
 Atm·cc·sec⁻¹ (US unit)
 Pa·m³·s⁻¹

1.2 Technical Data

Safety

The instrument meets the specifications of protection class 1 according to VDE 0411 (IEC 348).

1.2.1 Physical Data

| | |
|---|---|
| Max. measurable helium leak rate | 10 mbar·l·s ⁻¹ |
| Max. indicatable helium leak rate (qualitative measurement) | 10 ³ mbar·l·s ⁻¹ |
| Min. measurable leak rate with time constant | 2·10 ⁻¹⁰ mbar·l·s ⁻¹ < 1 s |
| Max. inlet pressure | |
| for quantitative measurement | 100 mbar |
| for qualitative measurement | 1000 mbar |
| Max. total gas flow at inlet with limit of detection | |
| 2·10 ⁻¹⁰ mbar·l·s ⁻¹ | 0.1 mbar·l·s ⁻¹ |
| 1·10 ⁻⁹ mbar·l·s ⁻¹ | 0.5 mbar·l·s ⁻¹ |
| 5·10 ⁻⁵ mbar·l·s ⁻¹ | 400 mbar·l·s ⁻¹ |
| Time until ready to display | ≤ 5 min |
| Detectable masses | 2, 3, 4 amu |
| Pumpdown times until ready for leak detection | |
| without additional volume | 6 s |
| with test-object volume 1 l | 6 s |
| with test-object volume 50 l | 150 s |

Note

The measurement units displayed can only be changed in a special operating mode of the instrument (PARAMODE). Refer to Annex 1.

Two „limit“ displays to indicate the low and high range limits.

Display capabilities for status

Light spots for display status
 MAX / ACT storage of max. value
 FAST / SLOW smoothing of measured value
 BACKGRND suppression of zero

Light spots for leak detection status
 PREC sensitivity
 VAC / SNIFF operating mode
 STOP / VENT status of test object
 CAL calibration
 CAT2 cathode 2

Key to Fig. 1

- 1 Keypad
- 2 Display unit
- 3 Work panel
- 4 Valve block
- 5 Compressed air supply
- 6 Forepump
- 7 Auxiliary pump
- 8 Mains transformer
- 9 High vacuum plug-in
- 10 Electronics plug-in

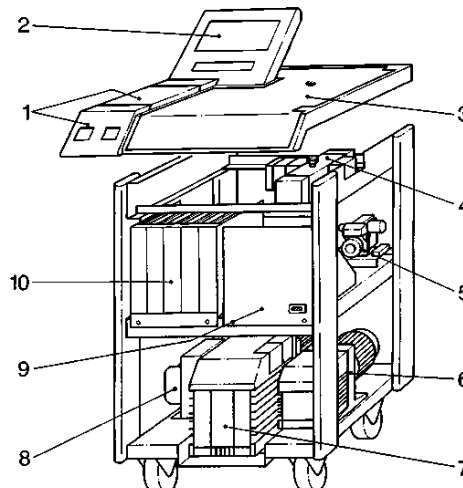

Fig. 1 Modules

| | |
|---|------------------------|
| Noise when running | max. 58 dBA |
| Dimensions (H x W x D) | 110.5 x 62.7 x 77.5 cm |
| Weight (with auxiliary pump TRIVAC D 25 B) | 205 kg |
| Cat.No. | 155 85 |

1.2.2 Electrical Data

| | |
|--------------------------------|--|
| Mains voltage, convertible | 100 V, 110 V, 127 V \pm 5 % 200 V, 208 V, 220 V, 240 V, 380 V \pm 5 % |
| Mains frequency | 50/60 Hz |
| Nominal power | $P_N = 2.2$ kW |
| Max. turn-on power | $P_S = 5.5$ kW |
| Mains connection for QUICKTEST | 220 V a.c. |

Caution This connection **always** carries **220 V a.c.** independently of the mains voltage.



| | |
|--|---|
| Recorder output | For recorder with an internal resistance of min. 2.5 k Ω |
| 1. Leak rate, linear | 1.0 - 9.9 V per decade |
| Leak rate exponent | 0.5 V per decade beginning with 1 V at 10 ⁻¹⁰ mbar·l·s ⁻¹ |
| 2. Leak rate, logarithmic | 0.5 V per decade beginning with 1 V at 10 ⁻¹⁰ mbar·l·s ⁻¹ |
| 3. Inlet pressure and fore pressure, logarithmic | 0.5 V per decade beginning with 1 V at 10 ⁻³ mbar |
| Headset output | |
| internal resistance of headset | min. 8 Ω , |
| output power | max. 500 mW |

1.3 Technical Description

1.3.1 Principle of Leak Detection

The UL 500 operates on the counterflow principle, i.e. helium diffuses against the turbomolecular pump's direction of flow into the mass spectrometer, while heavy gases, especially water vapours, are held back (mass-dependent compression capacity).

A cold trap in conjunction with liquid nitrogen is thus not needed.

A special feature of the UL 500 is the double-entry turbomolecular pump, whose inlet side at the test object ensures short response times. Furthermore, as a result the inlet of the UL 500 is not constantly linked to a forepump, hence preventing test objects from becoming contaminated with hydrocarbons.

The UL 500 thus achieves pumping and response times which are shorter than for the full-flow technique involving liquid nitrogen, without any appreciable reduction of sensitivity.

1.3.2 Double-Entry Turbomolecular Pump

The double-entry turbomolecular pump of the UL 500 combines in a single housing two turbomolecular pumps driven by a common motor.

The two turbomolecular pumps pump in opposite directions into a common forepressure connection.

One side of the turbomolecular pump (compression side) produces from the helium pressure in the foreline the helium pressure that is detected in the mass spectrometer. The pump's stable compression capacity for helium is exploited for this purpose. This capacity, together with the pumping capacity of the forepump, determines the sensitivity of the system.

The other side of the turbo pump (pump side) serves as a high-vacuum pump to evacuate the inlet resp. the test object.

The double-entry turbomolecular pump is a special pump for the UL 500; its designation is TURBOVAC 150.

1.3.3 Forepump

The forepump produces a proportional helium pressure from the helium flow entering the UL 500. The stable helium pumping capacity of the pump is exploited for this purpose. This capacity, together with the compression of one stage of the turbomolecular pump, determines the sensitivity of the system. A TRIVAC D 4 B rotary-vane vacuum pump is integrated in the UL 500 as forepump.

All data of the forepump are contained in the Operating Instructions GA 01.201.

1.3.4 Auxiliary Pump

The integrated auxiliary pump in the UL 500 evacuates a test object down to the pressure at which it can be connected to the pump side of the turbomolecular pump. In addition, it supports the forepump during leak detection in handling large gas quantities coming from the test object.

A TRIVAC D 25 B rotary-vane pump is installed in the UL 500 as auxiliary pump. For data of the auxiliary pump, see the Operating Instructions GA 01.202. Instead a TRIVAC D 16 B, D 40 B or D 65 B can be installed as auxiliary pump.

1.3.5 Mass Spectrometer

The main components of the mass spectrometer (MS) are an ion source, a magnetic separation system and an ion collector (3/5).

The ion source ionizes neutral gas particles, thereby generating an ion beam. Positively charged ions are accelerated out of the ion source and subsequently reach the magnetic field. There they are deflected into an orbit whose radius is dependent on the mass-to-charge ratio of the ions.

Only the helium ions meet the separation conditions and reach the ion collector, where they can be measured as current by the electrometer amplifier.

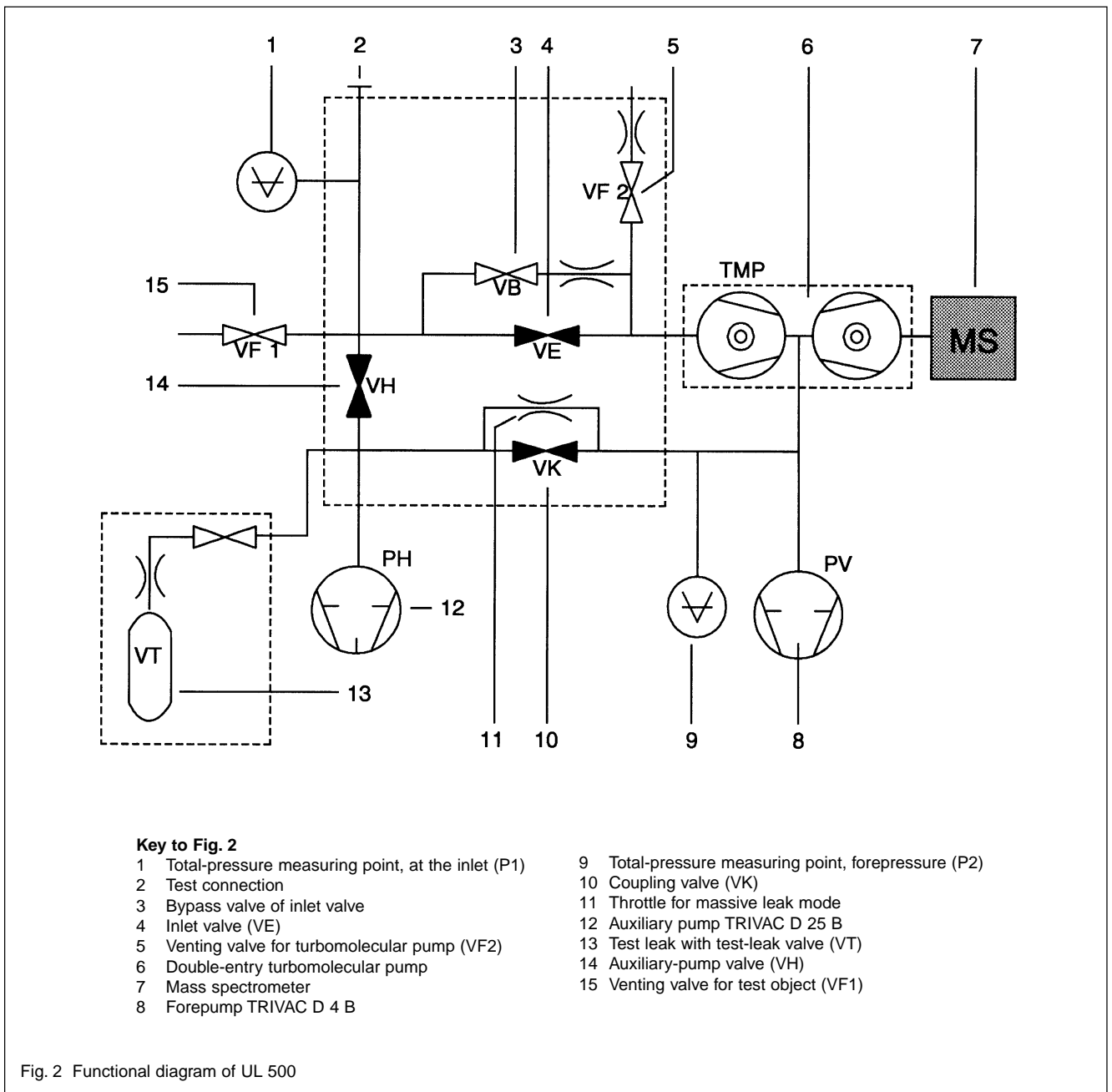

1.3.5.1 Ion Source

Electrons with 80 eV energy are used in the ion source. The electrons emerging from the hot cathode (3/1) are attracted by the positive anode (3/2). However, they do not immediately reach the anode (3/2), but oscillate to and fro for several times until finally reaching the wire spiral of the anode (3/2).

In this way the electrons ionize gas atoms through impact. These ions are extracted from the ion source by an extractor screen (3/10) connected to ground and enter the magnetic separation system.

The anode is heated during run-up to prevent polymerized hydrocarbon deposits (insulating layers that may impair the sensitivity).

After run-up the anode is no longer heated as the operating temperature of the ion source (cathode heating) is sufficient.

The cathodes (3/1) and (3/3) consist of iridium tape coated with thorium oxide. Owing to this thorium coating, the iridium filaments operate at a much lower temperature than tungsten ones and possess excellent resistance (burnout resistance) to embrittlement, oxygen, water vapour and hydrocarbons.

Caution Halogens or halogen-containing substances may adversely affect the service life of the cathodes.

1.3.5.2 Separation System

A magnetic sector field (3/8) with 180° deflection is used as separation system. Owing to the inhomogeneity of the magnetic field vertically in relation to the ion beam, additional concentration is achieved in this direction (Z-focusing), resulting in a high sensitivity.

The intermediate screen (3/9) ensures additional separation of unwanted ions of other gases.

1.3.5.3 Ion Collector

The ion collector (3/5) consists of a suppressor and its proper collector.

The suppressor has a positive potential slightly below the anode potential. It is designed to prevent scattered ions with a lower energy than required from reaching the collector. Resolution at low detection rates is thus improved.

The collector collects the incoming ions and neutralizes them. The corresponding current reaches the subsequent amplifier.

1.3.6 Electronics Modules

See Fig. 4.

1.3.6.1 Electrometer Amplifier

The electrometer amplifier amplifies the current generated at the ion collector of the mass spectrometer. Its gain can be changed in three stages. Changeover and processing of the analog output voltage are accomplished by the control unit. The detection limit in the most sensitive range is approx. $4 \cdot 10^{-15}$ A.

1.3.6.2 Mass Spectrometer Supply Unit

This unit generates all voltages and currents needed for operating the mass spectrometer:

- Anode heating voltage
- Cathode heating voltage

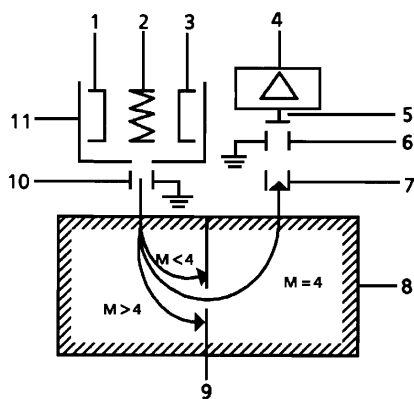

Key to Fig. 3

- 1 Cathode 1
- 2 Anode
- 3 Cathode 2
- 4 Amplifier
- 5 Ion collector
- 6 Shield for ion collector
- 7 Suppressor
- 8 Magnetic field
- 9 Intermediate screen
- 10 Extractor screen
- 11 Shield ring

Fig. 3 Schematic representation of the mass spectrometer

- Anode voltage
- Suppressor voltage

Malfunctions in the mass spectrometer are detected and communicated to the control unit. The latter monitors the mass spectrometer supply unit.

1.3.6.3 Turbomolecular Pump Supply Unit

This unit controls and monitors the turbomolecular pump. It is in turn monitored by the control unit, which thus controls the pump.

1.3.6.4 Power Distribution Unit

All circuits needed for operating and monitoring the rotary-vane pumps and valves are contained in the power distribution unit. This unit is in turn controlled by the control unit.

1.3.6.5 Power Conversion Unit

This unit generates from the AC supplied via the mains transformer all the DC supply voltages needed for operating the electronics units.

1.3.6.6 Control Unit

The control unit is the central component of the leak detector's electronics system. It controls and monitors all other modules. Its microprocessor is thus constantly informed of the status of the entire leak detector and can act accordingly. The control unit is linked to the operation and display unit so as to receive operator commands and to output measured values and messages.

1.3.6.7 Keypad and Display Unit

This unit serves the purpose of communication with the operator. It receives commands entered at the keypad and outputs measured values and messages via the display.

Like the control unit, this unit possesses a microprocessor. The two processors are in constant mutual contact for the purpose of exchanging commands and measured values.

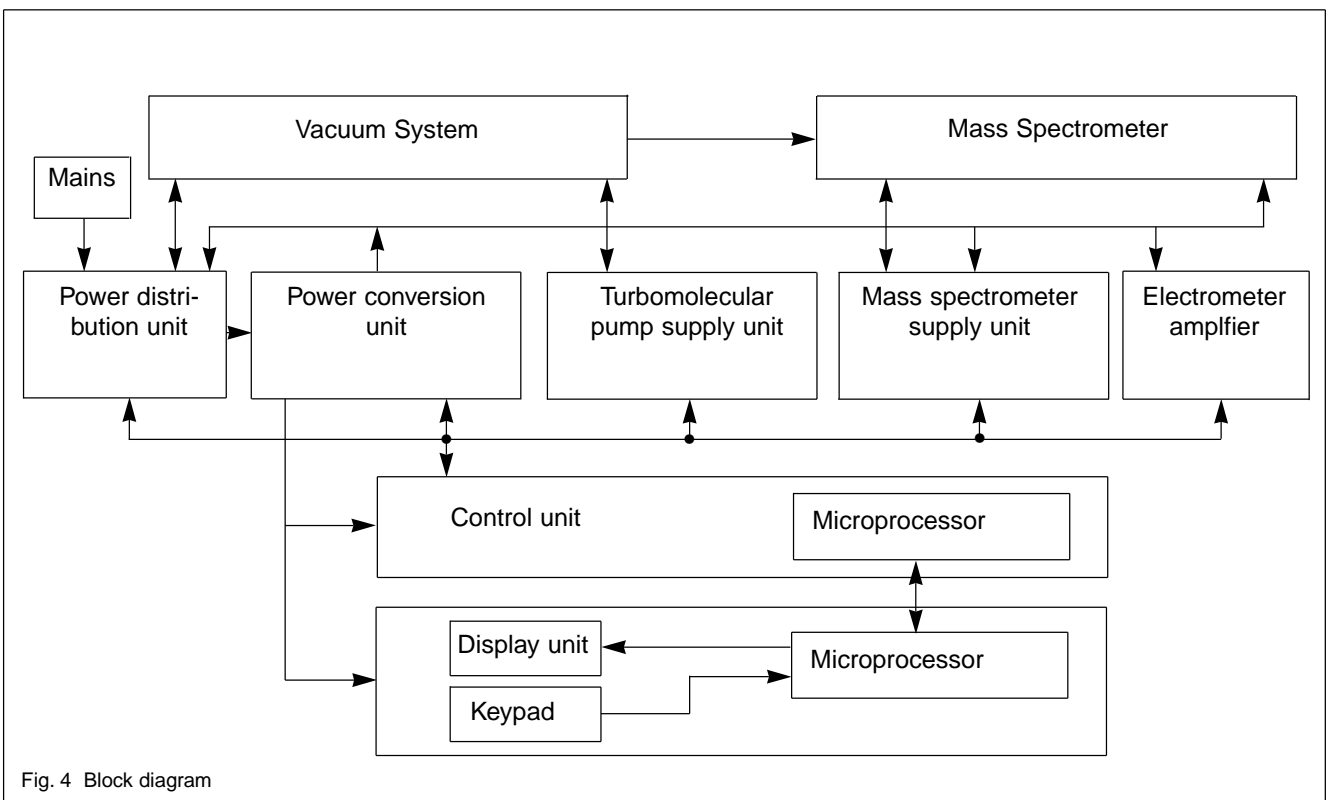

Fig. 4 Block diagram

1.4 Equipment

1.4.1 Standard Specification

The ULTRATEST UL 500 helium leak detector is delivered ready for use.

- UL 500 with built-in display unit and with power cord attached
- Set of gaskets
- Set of tools in bag
- Set of fuses
- Folder with operating instructions:
 - Rotary-vane vacuum pump
TRIVAC D 4 B = GA 01.201
 - Rotary-vane vacuum pump
TRIVAC D 25 B = GA 01.202
 - Spare parts list = ET 10.204
- 6-way plug for the recorder output, Ref. No. 500 17 119
- centering ring with grid insert for the inlet flange, Ref. No. 411 70 121

1.4.2 Accessories

| | Cat.No. / Ref. No. |
|--|---------------------------|
| Calibrated leak TL 9 | 155 81 |
| Calibrated leak TL 8 | 165 57 |
| Calibrated leak TL 6 | 155 66 |
| Calibrated TL 4 | 155 65 |
| Calibrated TL 4 - 6 | 155 80 |
| Reducer DN 40/16 | 183 89 |
| Helium spray gun with 5 m hose | 165 55 |
| Standard sniffer | 155 90 |
| Helium sniffer Quicktest | 155 78 |
| Headset | 165 07 |
| Interface V.24 / RS 232 C | 156 05 |
| Trigger outputs | 156 06 |
| Set of crane eyes | 200 59 475 |
| Solenoid gas ballast valves with air inlet | 200 59 643 |
| Antistatic work plate | 200 59 665 |
| Exhaust filter | 200 59 658 |
| Air filtering mat for the rear | 200 59 736 |
| Remote control | upon request |
| Air inlet for venting valve | upon request |

2 Operation

2.1 Installation of UL 500

When moving the UL 500 pull or push it only at its housing and not at the display.

When lifting the UL 500 with a crane, special preparations are required. See Section 1.1.2.

Moreover it is recommended to use a transport frame so that the lifting forces are applied perpendicularly to the work panel of the UL 500 and the profiles of the UL 500 are subjected only to pulling forces.

Caution



The **exclusive use** of standard crane eyes will result in damage to the display unit. The additional strengthening measures using the clamping pieces and screws must be introduced to prevent damage to the instrument.

2.1.1 Layout of Controls and Displays

Note

- Fig. 7 shows a list of the operating elements on the operating unit.

- Fig. 8 shows a list of the display elements on the display unit.

An overview of the controls on the top and front of the UL 500 is given in Fig. 5.

Caution

The mains socket (5/6) for the QUICK-TEST **always carries 220V a.c!**



In addition to the above controls (see Fig. 5) at the top and front of the UL 500, the headset connection (6/2), the loudspeaker (6/3), the loudspeaker volume control (6/1), the recorder connection socket (6/5) and the V.24 / RS 232 C interface connection socket (6/6)

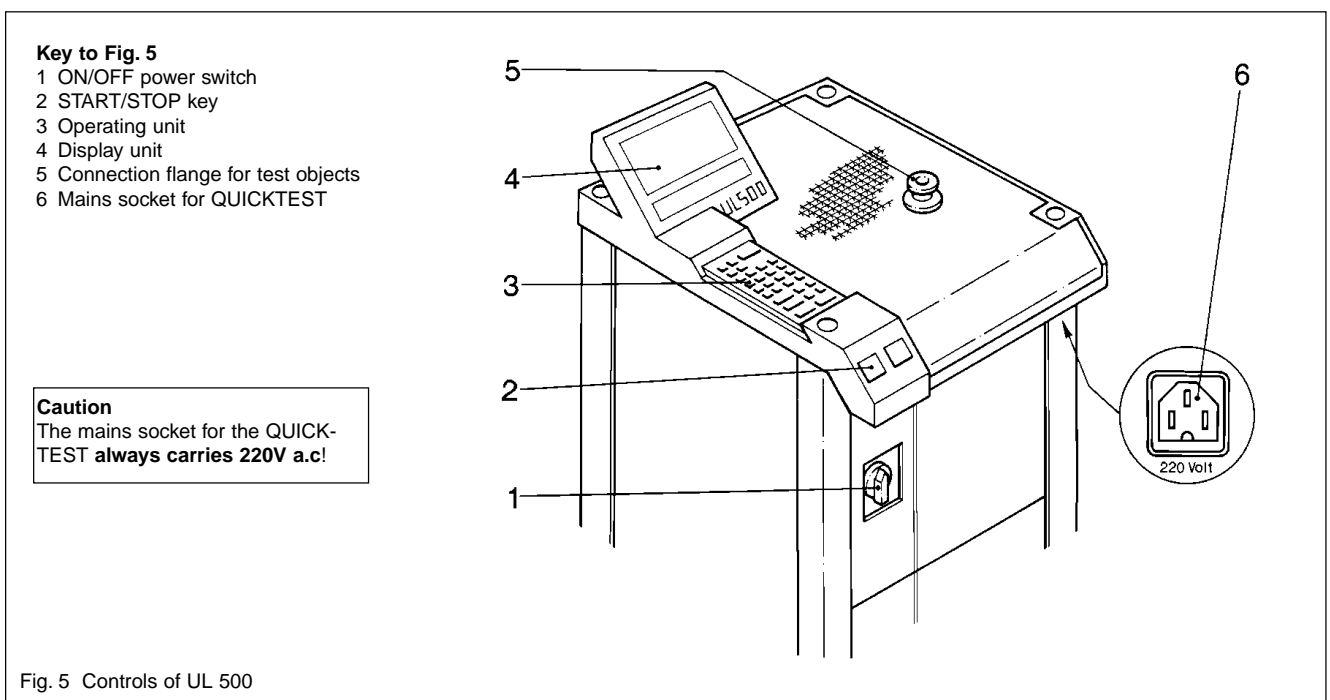

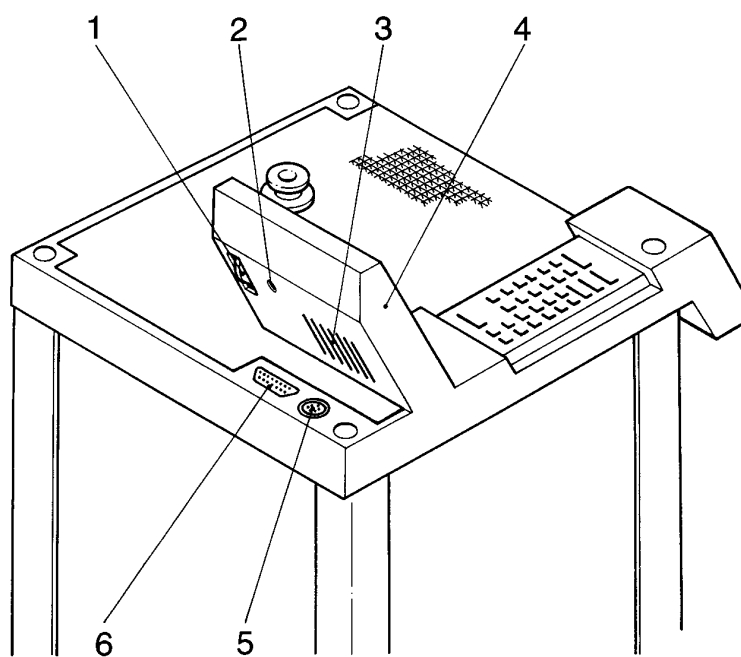

Key to Fig. 6

- 1 Volume control
- 2 Headset connection
- 3 Loudspeaker
- 4 Display unit
- 5 Connection socket for a recorder
- 6 Connection socket for V.24 / RS 232 C interface and trigger relay options

Fig. 6 Back of display unit

Key to Fig. 7

- 1 HELP**
Not used during normal operation.
- 2 OPT**
Start of an optional input / start or optional operating mode. Input of optional parameters.
- 3 EXEC**
Termination of an input and execution of the relevant command. Acknowledgement of a message by the operator.
- 4 CLR**
Cancellation of the last function entered.
- 5 EXP**
Setting the cursor to enter numbers in the exponent panels.
- 6 +/-**
Changing the sign when entering a number.
- 7 Arrow pointing to the right**
Moving the cursor (indicating the input position) to the right. Moving a lengthy display text further to the right.
- 8 Arrow pointing to the left**
Moving the cursor (indicating the input position) to the left. Moving a lengthy display text back to the left.
- 9 FAST / SLOW**
Switches the display to either fast or slow operating mode.
- 10 RATE / CONC**
Switches the display to indicate either leak rate or helium concentration.
- 11 MAX / ACT**
Switches the digital display to either „Retain the last maximum“ or „Display the currently measured value“.
- 12 PREC**
Switches the release of the most sensitive measuring range for autoranging either on or off.
- 13 ZERO**
Transfers the currently measured value to the display as „zero“.
- 14 STOP / VENT**
Terminates the pumping or measuring operation in progress. When pressed for longer than 2 s, it opens the inlet venting valve.
- 15 START / RESET MAX**
Starts the pumpdown and measurement operation. Transfer of currently measured value to the digital display and search for next maximum.
- 16 CAL**
Starts the internal or external calibration sequence.
- 17 INSP / MEAS**
Activates either the search mode or the measurement mode of the leak detector.
- 18 SNIFF / VAC**
Activates either the sniffing mode or the vacuum mode of the leak detector.
- 19 Point**
Input of the decimal point when entering a number.
- 20 Numeric keypad**
Digits 0...9
- 21 LIMIT HIGH**
Input of the upper limit of the measuring range to be displayed.
- 22 LIMIT LOW**
Input of the lower limit of the measuring range to be displayed.

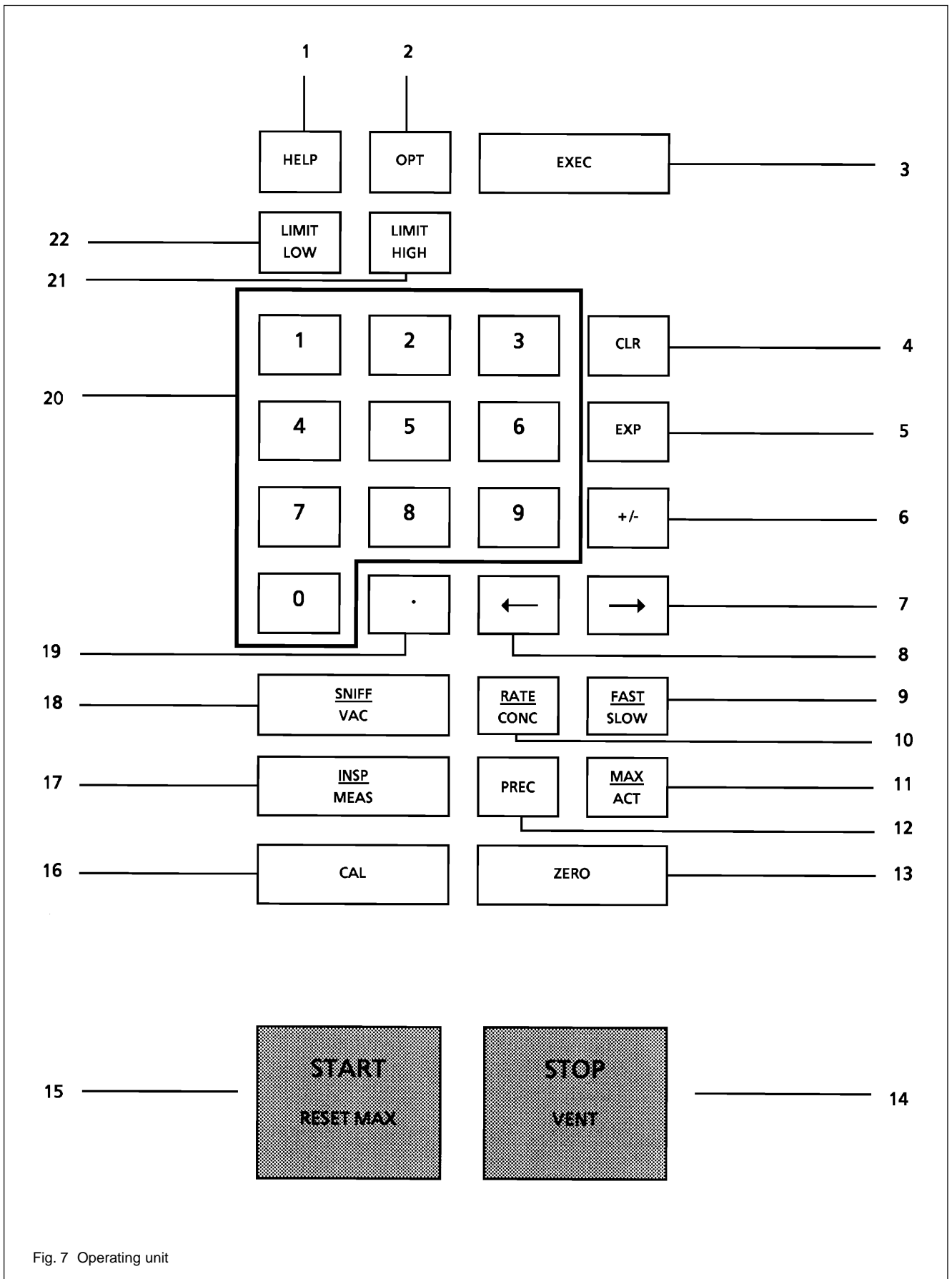
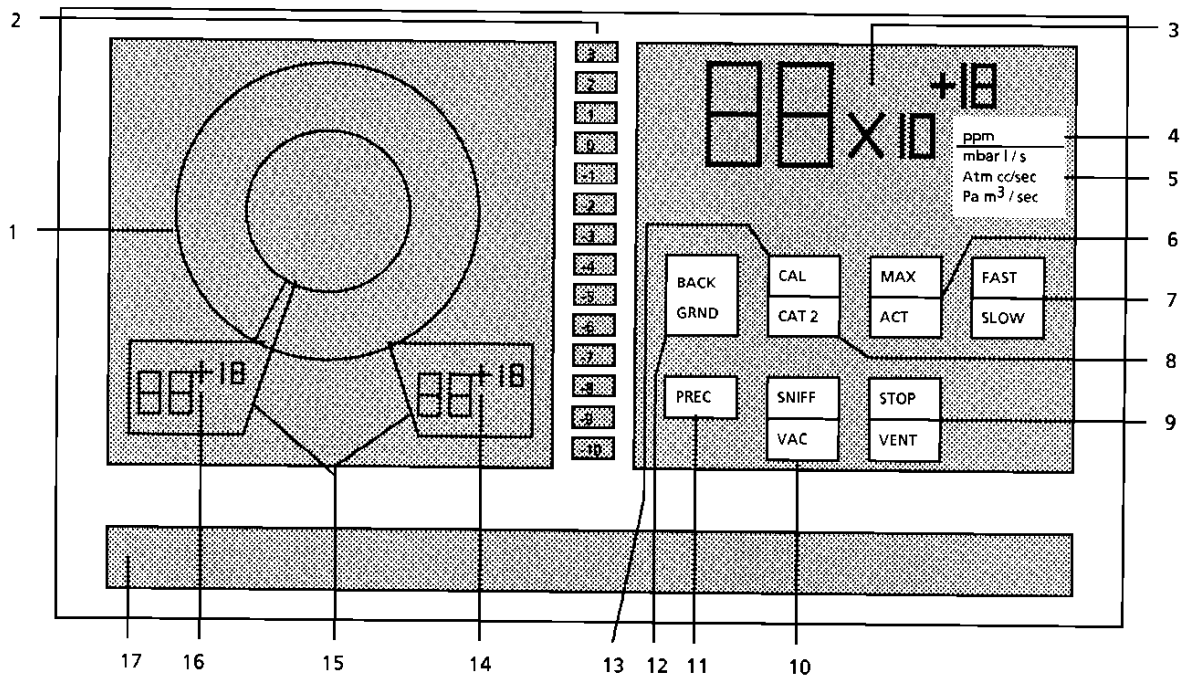

Fig. 7 Operating unit



Key to Fig. 8

- 1 Circular **quasi-analog display** of the leak rate in the „Inspect“ and „Measure“ modes. One revolution corresponds to one decade of the measuring range. Quasi-analog display of a measurement interval defined with the LIMIT values.
- 2 **Exponent scale**
For quasi-analog display of leak rate.
- 3 **Digital display of the measured value** as leak rate or concentration in the „MEASURE“ mode with mantissa and exponent.
- 4 **Unit** „ppm“ for „Concentration“ mode.
- 5 **Units** for „Rate“ mode.
- 6 **MAX / ACT**
Indicates the current operating status of the digital display.
- 7 **FAST / SLOW**
Indicates the current speed of overall display reaction.
- 8 **CAT 2**
Informs the operator that the second cathode of the ion source has been put into service.
- 9 **STOP / VENT**
Indicates the current operating status of the leak detector.

- 10 **SNIFF / VAC**
Indicates the current operating mode of the leak detector.
- 11 **PREC**
Indicates that the PRECISION measuring range for AUTORANGING has been released.
- 12 **BACKGRND**
Indicates that zero has been shifted for the displayed measured value.
- 13 **CAL**
Indicates that the operator should perform calibration.
- 14 **Digital display** for indicating and entering the high limit of a restricted measurement interval.
- 15 **Marks** for LIMIT LOW and LIMIT HIGH on the display in the interval measurement mode.
- 16 **Digital display** for indicating and entering the low limit of a restricted measurement interval.
- 17 **Alphanumeric display** line to show messages for the operator and to check the input of parameters by the operator.

Fig. 8 Display unit

Key to Fig. 9

- 1 Rear panel of UL 500
- 2 Terminal strip
- 3 Plug-in jumpers
- 4 Transparent plastic plate
- 5 Mains cord
- 6 Exhaust D 4 B
- 7 Exhaust D 25 B
- 8 Connection of air supply option
- 9 Label giving the set mains voltage (on plastic panel)
- 10 Label giving the electrical data
- 11 Plate with serial number

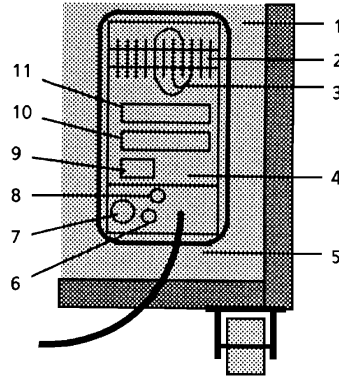

Fig. 9 Mains connection, name plates and exhaust connections

2.1.2 Preparations for Initial Startup

The UL 500 is delivered ready for use. The integrated rotary-vane pumps are filled with oil. The mains connection has to be matched to the existing mains voltage (see Section 2.1.2.1).

Caution



When operating the UL 500 in rooms and especially when leaktesting large-volume test objects or when operating the gas ballast, the exhaust connections (9/6) and (9/7) must be lead to the outside via suitable hoses.

As an alternative exhaust filters may be mounted (see Section 1.4.2).

In rooms with helium concentrations significantly above 5 ppm the use of air supply lines is recommended. In such cases helium-free air should be fed via a line to the venting valve (VF 1; 2/15). Special accessories are available for this purpose upon request.

Note

- Prior to initial startup, check the oil level of the auxiliary pump and forepump (see Section 3.1).
- Before connecting the UL 500 to the mains, check whether the mains voltage matches the voltage required (see Section 2.1.2.1).

2.1.2.1 Electrical Connections

Note

In general, the currently valid VDE 0100 regulations must be observed.

The transformer integrated in the UL 500 permits an universal adaptation to mains voltages used throughout the world, see Section 1.2.2. This is achieved by inserting several plug-in jumpers (9/3) into a terminal strip (9/2). The required position depending on the local mains voltage is given in Fig. 10.

A connection diagram for the different mains voltages according to Fig. 10 is also given inside the UL 500 on its rear panel.

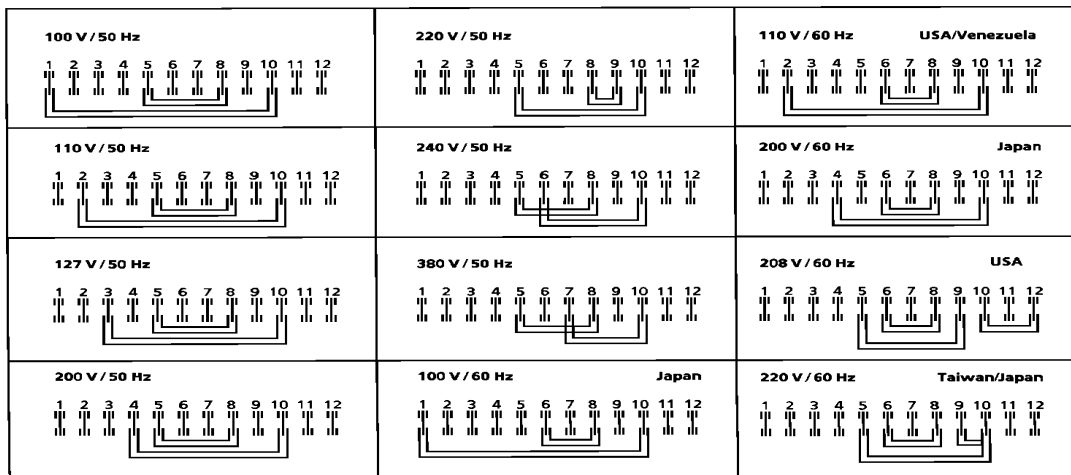

Fig. 10 Jumpers on the terminal strip for adaptation to different mains voltages

The mains voltage is adapted on terminal strip (9/2) at the rear of the UL 500 above the inlet for the power supply cord (9/5) and behind a transparent plastic plate (9/4). The factory set mains voltage is shown on the information label (9/9) mounted there.

Caution



The equipment voltage printed on the information label must correspond to the available mains voltage.

2.2 Description of Controls

Note

- Fig. 7 shows a list of the operating elements on the operating unit.
- Fig. 8 shows a list of the display elements on the display unit.

The UL 500 is designed for maximum simplicity and clarity of operation. Hence most of the control operations that can be executed via the keys, are supported by displays. Apart from the information in the following, descriptions of the individual key functions, the meanings of the displays are explained in Section 2.3. Also refer to:

- the list of operating elements see Fig. 7
- the list of display elements see Fig. 8

2.2.1 Power Switch

The entire leak detector is switched on by actuating the power switch.

The UL 500 first conducts a selftest of individual modules. If concluded with no faults, the pumps are switched on. After the turbomolecular pump has been run up (approx. 4 min), the UL 500 is ready to operate.

The UL 500 employs the alphanumeric display (8/17) to inform the operator of all automatically executed actions (see Section 2.4).

Note

During the selftest the turbopump valve VF2 is briefly actuated for testing purposes.

After completion of run-up the UL 500 is set automatically to the operating condition at the time it was switched off. All required parameters for this are stored in a battery-backed-up memory.

(The life of the battery is 6 years approx.)

The following parameters are stored when switching off:

- LIMIT LOW value
- LIMIT HIGH value
- LIMIT LOW ON / OFF
- LIMIT HIGH ON / OFF
- INSP or MEAS

- SNIFF or VAC
- RATE or CONC
- PREC on or off
- Status of the alphanumeric display (display P 1, P 2)
- Status of the recorder output (Output of P 1, P 2; leak rate linear or logarithmic)
- Status of the V.24 / RS 232 C option
- Status of the trigger option
- Equipment-specific parameters, programmed in the PARA MODE (see Annex 1)
- Factors from OPT CALEMV
- Anode voltage (value determined through AUTOTUNE)

2.2.2 „SNIFF / VAC“ Key



Note

The SNIFF / VAC key (7/18) may only be actuated in the STANDBY mode.

The „SNIFF / VAC“ key (7/18) is employed to select the basic operating modes SNIFF and VAC.

Changeover between SNIFF and VAC necessitates a few changes in the control sequence of the UL 500. The changeover is not carried out until acknowledged by pressing the „EXEC“ key (7/3). The operator receives the necessary information via the alphanumeric display line (8/17) and via the display „SNIFF“ and „VAC“ (8/10). The display of the mode still valid is lit, that of the mode which can be selected flashes at the same time.

2.2.2.1 Vacuum Mode

In this operating mode, leak detection can be conducted with the basic UL 500 unit.

The test object is evacuated with the integrated pumps of the UL 500 and sprayed with helium from the outside to localize leaks (also see Section 2.5). The mode is indicated by the display VAC (8/10) lighting up. The indicated measured values are always leak rates; it is possible for the display to indicate either of the following units (8/4) or (8/5):

- mbar·l·s⁻¹,
- Atm·cc·sec⁻¹ (USA unit)
- Pa·m³·s⁻¹

These units are default units of the UL 500 and they can only be changed in a special operating mode (PARA MODE, see Annex 1).

2.2.2.2 SNIFF Mode

In this operating mode, the UL 500 is normally operated with an external sniffer unit. This mode is indicated in the SNIFF display panel (8/10). It is possible to indicate the measured values as a helium concentration (ppm) or as a leak rate (mbar·l·s⁻¹) or as the unit which can only be

changed in the PARA MODE. The RATE/CONC (7/10) key is used for the switchover.

2.2.3 „INSP / MEAS“ Key



The INSP / MEAS key (7/17) can be pressed to choose between the INSPECT mode and the MEASURE mode. The major difference between them is the measurement accuracy.

2.2.3.1 „INSPECT“ Mode

Starting from the MEASURE mode, the INSPECT mode is activated by pressing the „INSP / MEAS“ key (7/17) and acknowledging the function with the „EXEC“ key (7/3).

The INSPECT mode gives the operator a quick overview of existing leaks and their location, without a quantitative display of a precise measured value. The representation is only via the quasi-analog display (8/1) and (8/2). The digital display (8/3) is deactivated in this operating mode, thus eliminating the possibility of switching over from „Retain the last maximum“ (MAX) to „Display the currently measured value“ (ACT) (see Section 2.2.10). It is not possible to calibrate the UL 500 in the INSPECT mode (see also Sections 2.2.7 and 2.7). The PRECISION function (7/12) cannot be selected.

2.2.3.2 MEASURE Mode

Starting from the INSPECT mode, the MEASURE mode is activated by pressing the INSP/MEAS key (7/17) and acknowledging the function with the „EXEC“ key (7/13).

The MEASURE mode is employed for quantitative determination of a leak. The measured leak rate is indicated both on the quasi-analog display (8/1) and (8/2) and on the digital display (8/3).

If possible, the UL 500 should be calibrated before operating it in the MEASURE mode (also see Sections 2.2.7 and 2.7).

2.2.4 „START / RESET MAX“ Key



The „START / RESET MAX“ key (7/15) assumes either of two functions depending on the main status of the UL 500.

2.2.4.1 „START / RESET MAX“ Key in STANDBY

Starting from the STANDBY mode of the UL 500, evacuation of a test object connected is initiated by pressing the „START“ key. The UL 500 operates with automatic measuring range selection, the AUTORANGING (see Section 2.8.3).

The measured values appear on the display in the following fashion:

- The circular display (8/1) in conjunction with the exponential scale (8/2) shows the current leak rate.
- The digital display (8/3) appears only in the MEASURE mode (7/17). Its function still depends on the type of display selected via MAX / ACT (7/11).

The message „DETECTING INSPECT“ or „DETECTING MEASURE“ appears on the alphanumeric display (8/17) if no special function of this display has been selected by pressing the „OPT“ key (7/2).

2.2.4.2 „START / RESET MAX“ Key in DETECT Mode

Starting from the DETECT mode already initiated, i.e. after having already pressed the „START“ key once, and with display type „Retain the last maximum“ (MAX) (7/11) activated, the RESET MAX function is executed every time the key is pressed.

From the point of actuation onward, all current leak rate values are displayed which are higher than a preceding one. The next max. value is sought and stored in the display.

Note

If the ACT display type (display the currently measured value) is activated, pressing the „RESET MAX“ key is ineffectual.

2.2.5 „STOP / VENT“ Key



The „STOP / VENT“ key (7/14) has either of two functions depending on how long it is pressed.

2.2.5.1 „STOP“ Function

Starting from the DETECT mode of the UL 500, evacuation of the test object is interrupted by pressing the „STOP“ key (7/14). To do so, the key must be pressed for less than 1.1 s. The unit switches to the STANDBY mode, i.e. all valves are closed.

Next a correction of the internal Zero level is carried out for the ranges FINE 3 and PREC. For this the coupling valve VK is opened briefly and then shut. At the same time the last internal leak rate signal is displayed which was determined as the offset after the last Zero determination in the two measurement ranges.

This takes approximately 10 s.

After Zero correction the detection limit is displayed.

The operator is informed of the status by the „STOP“ display (8/9) lighting up. In addition, the message „STANDBY FOR MEASURE“ or

„STANDBY FOR INSPECT“ appears in the alphanumeric display line (8/17) if no special function of the display has been selected by pressing the OPT key (7/2).

Note

If the UL 500 is already in the STANDBY mode, pressing the STOP key again will let the UL 500 determine the background.

2.2.5.2 „VENT“ Function

The VENT function is achieved only if the „STOP / VENT“ key (7/14) is held down for more than 1.1 s. After this period the inlet vent valve VF1 (2/15) is opened. The VENT indicator (8/9) lights up to report this operating mode. The valve VF1 can be closed again by:

- Briefly pressing the „STOP / VENT“ key again. The UL 500 then enters the STANDBY mode.
- Pressing the „START / RESET MAX“ key. The UL 500 then enters the DETECT mode.

2.2.6 „ZERO“ Key

ZERO A constant leak rate display can be suppressed by means of the ZERO function such as for example a constant helium background of a test sample.

The Zero function is only active in the DETECT mode, i.e. it is not possible to suppress internal backgrounds of the UL 500 itself. This is done by pressing the „STOP“ key. See Section 2.2.5.1. Pressing the „ZERO“ key (7/13) initiates storage of the current leak rate as „Zero“ without changing the internal Zero.

Only values above this Zero are displayed, resulting in enhanced resolution of the displayed measurement signal.

If measured values occur that are below the stored zero-point, an automatically floating zero-adaptation initiates storage of these negative leak rates as new zero points.

To draw the operator's attention to the suppressed background, the red warning indicator BACKGROUND (8/12) lights up. The enhanced resolution is limited by the measurement accuracy of the UL 500.

The zero, set through the ZERO function is derived from the actual measured value by:

- Setting the meas.-value mantissa to 0.0.
- Shifting the measured-value exponent by one decade.

Example:

Measured value $7.4 \cdot 10^{-3}$ after pressing the „ZERO“ key:
Display $0.0 \cdot 10^{-4}$ Exceptions:

- Normal AUTORANGING: At leak rates under $1.0 \cdot 10^{-8}$ mbar·l·s⁻¹ the exponent is not switched over any more.
- AUTORANGING with PRECISION: At leak rates under $2.0 \cdot 10^{-9}$ mbar·l·s⁻¹ the exponent is not switched over any more.

The ZERO function is deactivated by pressing the ZERO key again.

The ZERO function is automatically deactivated if the STOP / VENT key (7/14) is actuated.

Note

The Zero function acts only upon the display and not the recorder output.

2.2.7 „CAL“ Key

CAL Internal or external calibration is initiated by pressing the „CAL“ key (7/16). The UL 500 controls all subsequent steps automatically.

The UL 500 discerns automatically between internal calibrated leak and external calibrated leak which is connected to the inlet flange, depending on the operating mode at the point of entering the CAL command:

- Pressing the „CAL“ key (7/16) in the DETECTING mode: external calibration
- Pressing the „CAL“ key (7/16) in the STANDBY mode: Internal calibration

If an external calibration is to be performed the calibrated leak has to be connected to the inlet flange beforehand.

After pressing the „CAL“ key it is still possible to switch over between internal and external calibration by pressing „START“ (7/15) and „STOP“ (7/14).

The sequence varies depending on the operating mode of the UL 500 (also see Section 2.7.2).

Note

- After actuating the „CAL“ key (7/16), the initiation of calibration must additionally be acknowledged by pressing the „EXEC“ key (7/3).
- This initiation and the running process can be terminated by pressing the „CLR“ key (7/4).

2.2.8 „RATE / CONC“ Key

**RATE
CONC** The „RATE / CONC“ key (7/10) is used to change the measured value presentation from RATE to CONC, and vice versa. It is effectual only in the SNIFF mode of the UL 500.

RATE The measured value is displayed as leak rate in the unit selected (8/5).

CONC The helium concentration is shown in ppm (8/4).

2.2.9 „PREC“ Key

 Pressing the „PREC“ key (7/12) influences the meas. range of the UL 500 during AUTORANGING, i.e. with this key the release of the most sensitive measuring range is activated or deactivated.

The measuring range attainable by AUTORANGING normally ends at a leak rate of approx. $1 \cdot 10^{-9}$ mbar·l·s⁻¹. After pressing the „PREC“ key (7/12), maximum sensitivity is released for the detection of a leak rate of $2 \cdot 10^{-10}$ mbar·l·s⁻¹.

This release must be acknowledged by actuating the „EXEC“ key (7/3). The request for the operator to do so appears in the alphanumeric display line (8/17), while the PREC indicator (8/11) flashes.

This function can be cleared by operating the „CLR“ key (7/4).

The PRECISION function is indicated by the PREC display (8/11) staying lit.

Note

The PRECISION function is only possible in the MEASURE mode (7/17).

Leak rates under $1 \cdot 10^{-9}$ mbar·l·s⁻¹ can not be measured until the test object's pressure is sufficiently low, which is reached in the course of evacuation. This is noticeable especially when large volumes are involved.

The function is deactivated by pressing the PREC key (7/12) again and acknowledging via the EXEC key (7/3).

2.2.10 „MAX / ACT“ Key

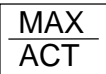
 The MAX / ACT key (7/11) can be used to select two functions:

- Retain the last maximum (MAX)
- Display the currently measured value (ACT)

Starting from the function just set, the function changes every time the key is pressed and this is visually represented on the MAX and ACT indicators (8/6).

The functions can only be selected in the MEASURE and DETECTING modes.

The key has no function in the INSPECT mode.

2.2.10.1 „MAXIMUM“ Function

Pressing the „MAX / ACT“ key (7/11) to obtain the function „Retain the last maximum“ has the result that only the maximum measured value which has occurred up to this point is shown in the digital display (8/3). The analog

circular display (8/1) and the exponential scale (8/2) are not affected. They always show the currently measured value.

Pressing the „START / RESET MAX“ key (7/15) clears the max. value being displayed, and the currently measured value appears. The next measurement cycle begins, with the max. measured value again being stored on the digital display.

Pressing the STOP/VENT key (7/14) clears the MAXIMUM function.

2.2.10.2 „ACTUAL“ Function

With this type of display the currently measured value is always indicated on the digital display (8/3) and on the quasi-analog display (8/1) and (8/2).

2.2.11 „FAST / SLOW“ Key

 The FAST / SLOW key (7/9) switches over the speed of the measured-value display. FAST results in the display reacting quickly; with SLOW an unsettled measured-value reading is damped to a greater degree.

Note

The FAST function should be selected when wanting to localize leaks.

The function changes whenever this key is pressed. The function just selected is shown on the display (8/7).

2.2.12 Numeric Keypad

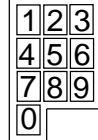
 The numbers 0 to 9 (7/20) are employed to enter parameters required to operate the UL 500.

2.2.13 Decimal Point Key (.)

 The decimal point key (7/19) is used in combination with the numeric keypad (7/20) to enter digits.

2.2.14 „EXP“ Key

 The „EXP“ key (7/5) is used when entering numbers. The possible input point (cursor) immediately jumps to the first digit of the exponent when the key is pressed.

2.2.15 „PLUS / MINUS“ Key (+/-)

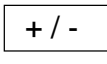
 The „PLUS / MINUS“ key (+/-) (7/6) is used to change the sign when entering numbers.

2.2.16 „Arrows LEFT/RIGHT“ Key

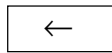
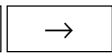
  The keys Arrow pointing RIGHT (7/7) and Arrow pointing LEFT (7/8) have several functions:

- When entering numbers for the functions LIMIT LOW (7/22) and (8/16) and LIMIT HIGH (7/21) and (8/14), the input position (cursor) is moved to the right or left by pressing the key (7/7) or (7/8), respectively. The position just selected flashes. The same function is employed in conjunction with inputs made via the alphanumeric display line (8/17).
- With LIMIT LOW and LIMIT HIGH (measurement range interval) active the display range can be shifted up or down by one decade. Thus it is possible to manually set the measurement range (manual ranging).
- Selection of an option (see Section 2.2.19).



2.2.17 „CLR“ Key

 The „CLR“ key (7/4) is used to cancel the last function entered.

The following functions are possible:

- Clear the command INSPECT / MEASURE.
- Clear the command SNIFF / VACUUM.
- Clear the command PRECISION.
- Clear the command CALIBRATE.
- Clear the command LIMIT LOW.
- Clear the command LIMIT HIGH.
- Clear the command OPTION.
- Clearing the display in case of a momentary error.
- Clearing the entry of the last entered programmed parameter.
- Termination of CAL.
- Termination of OPT AUTOTUNE.
- Termination of OPT ZERO.
- Termination of OPT CALEMV.

2.2.18 „LIMIT LOW / LIMIT HIGH“ Keys

  With the aid of the „LIMIT LOW“ (7/22) and „LIMIT HIGH“ (7/21) keys it is possible to enter a lower or higher limit for the measuring range.

LIMIT LOW affects only the possible measuring range of the UL 500, while LIMIT HIGH also changes the representation on the analog circular display.

The LIMIT HIGH function depends on LIMIT LOW. LIMIT HIGH can only be operated if LIMIT LOW has already

been activated.

Pressing one of the keys causes the corresponding digital display (8/14) or (8/16) to light up. The last limit value entered in the UL 500 appears with its first digit flashing. The following keys can be employed to change the numeric value:

Numeric

keypad: Changing the flashing digit by writing over it.
Point: Shifting the flashing input position to the decimal point.

Exponent: Shifting the flashing input position to the tens position of the exponent. This position can only be occupied with 0 or 1. An input automatically moves the input position forward to the ones position.

+ / -: Changing the sign of the exponent.

Arrow

left / right: Shifting the cursor through mantissa and exponent.

The following are also necessary to input the limit values:
EXECUTE: The „EXEC“ key terminates the input and accepts the number as the limit for measured values.

CLEAR: The „CLR“ key (7/4) terminates the function of the limit for measured values. The number in the display is cleared.

2.2.18.1 Operation with Only „LIMIT LOW“ Activated

The numeric value entered defines the minimum leak rate which can be displayed. The AUTORANGE process is limited at the sensitivity associated with this leak rate. Normal measurement operation of the UL 500 and the display functions remain unchanged.

Pressing LIMIT LOW (7/22) and CLR (7/4) one after the other deactivates a low limit that has been set. The last numeric value entered remains stored and is shown again whenever LIMIT LOW is pressed.

2.2.18.2 Operation with „LIMIT LOW“ and „LIMIT HIGH“ Activated

The numeric values entered for the limits define the minimum and maximum leak rates which will be indicated.

The LIMIT HIGH function (7/21) can only be called if a lower measurement limit has already been entered with LIMIT LOW (7/22). Deactivating the low limit automatically deactivates the high limit as well. Deactivating the high limit alone initiates the transfer to the LIMIT LOW function (see Section 2.2.18.1).

Entering LIMIT HIGH changes the representation on the analog circular display (8/1). Two arrow symbols are displayed to indicate the possible representation range. The entire measuring range between the limits is now shown on this limited circular display.

The same also applies for the frequency range of the acoustic signal.

Note

The interval must always be equal to, or exceed one decade.

If the upper limit is not entered a corresponding error message will be displayed.

Through LIMIT LOW the operation of the AUTORANGING is limited in the direction of higher sensitivities. However, LIMIT LOW has no effect on the switching in the direction of lower sensitivities at higher leak rates. If a measured value exceeds a set upper limit a segment above the limit value starts to flash and a warning signal can be heard.

2.2.18.3 Manual ranging in connection with set upper and lower limit

The keys „→“, „←“ can be used to shift the measurement range interval as set through LIMIT HIGH and LIMIT LOW by one decade up or down each time the arrow key is pressed. Thus it is possible to select the measurement range manually at a freely selectable resolution (minimum one decade).

2.2.19 „OPT“ Key

With the aid of the „OPT“ key (7/2) it is possible to select or control optional functions of the UL 500 to which no key has been specifically assigned.



After pressing the „OPT“ key, the desired function can be selected with the support of a menu which indicates the designation of the option and the option number in the alphanumeric display line (8/17). On activating the OPT key, the last option selected is always displayed again, or after switching the unit on, option number 01 appears.

The low-order position of the option number flashes and can be changed. An option can be selected by means of - the two arrow keys. The arrow to the right increases the option number, and the arrow to the left decreases it. Like this, the operator can easily obtain overview of all option functions. - the numeric keys. A digit is directly entered at the flashing low-order position; if a second digit is entered, the first is shifted to the high-order position. In this way, a specific option function can be directly selected.

Execution of a desired option function is initiated by pressing the „EXEC“ key (7/3). If the function produces a display in the alphanumeric display line, the display remains there until a key is actuated. The following applies:

- Pressing the „OPT“ key (7/2) causes the option menu to reappear.
- Pressing any other key produces a normal operational

display of the UL 500.

To cancel a request for an option, press the „CLR“ key (7/4). If an option number has not been assigned a function, the following display appears: OPT UNAVAILABLE.

The following optional functions are available in software version 1.7:

01: Display P1 ON (OFF)

Switches on the continuous display of pressure P1 (inlet pressure) in the alphanumeric display line.

This display is switched off by reselecting OPT 01: DISPLAY P1 OFF.

Display of P1 causes display of P2 to be switched off.

02: Display P2 ON (OFF)

Switches on the continuous display of pressure P2 (foreline pressure) in the alphanumeric display line.

This display is switched off by reselecting OPT 02: Display of P2 causes display of P1 to be switched off.

03: DISPLAY DATE

Switches the alphanumeric display briefly (approx. 1s) to display the current date: The display indicates:

DATE dd.mm.yy
(d = day, m = month, y = year)

Note

This is only displayed provided the clock module has been built into the control pcb. Otherwise the following message is displayed:

NOT AVAILABLE

04: DISPLAY TIME

Switches the alphanumeric display briefly (1s) to display the current time: The display indicates:

TIME hh.mm.ss
(h = hour, m = minute, s = second)

Note

This is only displayed provided the clock module has been built into the control pcb. Otherwise the following message is displayed:

NOT AVAILABLE

05: GASBALLAST OP/ CLO

Opens and closes the optional electromagnetically actuated gas ballast valves of the pumps PH and PV.

When the valves are open this is continuously indicated on the alphanumeric display:

GASBALLAST OPEN

The display will become erratic while the pumps give off helium, thus preventing sensitive measurements.

Note

This function can only be selected provided the opti-

on is built-in. The presence of this option is automatically sensed upon switching on of the UL 500. If the option is not built-in this condition is sensed and when selecting OPT 05 the display indicates:

NOT AVAILABLE

06-09: OPT UNAVAILABLE

No functions assigned yet.

10: TRIGGER ON/OFF

Switches the functions of the optional trigger relay pcb. on and off. The leak rate values at which the relays are actuated are entered through the function LIMIT LOW and LIMIT HIGH. Moreover the limits have to be set to active so that the relays can switch according to the set thresholds.

Note

- This function can only be switched on provided the trigger relay pcb. has been built in. The presence of this option is sensed automatically when switching the UL 500 on.
- If the trigger relay option is not sensed and when selecting OPT 10 the display indicates:

10: NO TRIGGER

11: LK REC LOG ON (OFF)

Switches on the output of the leak rate at the recorder output in logarithmic form. When reselecting OPT 11 the output switches off.

The recorder output is assigned as follows:

Channel 1

(pin 5 of recorder socket)

Output of leak rate with 1.0 V to 10 V, 0.5 V per decade.

1.0 V corresponds to a leak rate of $1.0 \cdot 10^{-10}$ mbar·l·s⁻¹ and
1.5 V corresponds to a leak rate of $1.0 \cdot 10^{-9}$ mbar·l·s⁻¹ etc.

The associated ground wire is pin 3 of the recorder socket.

Channel 2

Channel 2 is not used.

The options OPT 11, OPT 12, OPT 13 and OPT 14 switch each other over.

12: LK REC LIN ON (OFF)

Switches on output of the leak rate at the recorder output in linear form. The output is switched off by reselecting OPT 12.

The recorder output is assigned as follows:

Channel 1

(pin 5 of recorder socket). Output of leak rate with 1.0 V to 9.9 V per decade.

The associated ground wire is pin 3 of the recorder socket.

Channel 2

(pin 1 of recorder socket) Output of leak rate exponent in steps of 0.5 V per decade.

1.0 V corresponds to the exponent -10; 1.5 V corresponds to -9, etc.

13: P1 - REC LOG ON (OFF)

Switches on output of pressure p_1 (inlet pressure) at the recorder output. The output is switched off by reselecting OPT 13.

Output in logarithmic form:

Channel 1

(pin 5 of recorder socket) Output of pressure with 1.0 V to 10 V in 0.5 V per decade.

1.0 V corresponds to a pressure of $1.0 \cdot 10^{-3}$ mbar, and
1.5 V corresponds to a pressure of $1.0 \cdot 10^{-2}$ mbar.

The associated ground wire is pin 3 of the recorder socket.

Channel 2

Channel 2 is not used.

The options OPT 11, OPT 12, OPT 13 and OPT 14 switch each other over.

14: P2 - REC LOG ON (OFF)

Switches on output of pressure p_2 (foreline pressure) at the recorder output. The output is switched off by reselecting OPT 14.

Output in logarithmic form:

Channel 1

Channel 1 (pin 5 of recorder socket) Output of pressure with 1.0 V to 10 V in 0.5 V per decade.

1.0 V corresponds to a pressure of $1.0 \cdot 10^{-3}$ mbar, and 1.5 V corresponds to $1.0 \cdot 10^{-2}$ mbar.

The associated ground wire is pin 3 of the recorder socket.

Channel 2

Channel 2 is not used.

The options OPT 11, OPT 12, OPT 13 and OPT 14 switch each other over.

15: OPT UNAVAILABLE

No function assigned yet.

16: DISP TMP ROTOR

Displays once the current frequency of the rotor of the turbomolecular pump (revolutions per second).

Display: TM-PUMP ROT: xxx RPS

For the measurement the turbomolecular pump is switched off briefly.

17: DISP TMP GENERAT

Displays once only the current generator frequency of the turbomolecular pump (revolutions per second).

Display: TM-PUMP GEN: xxx RPS

The nominal rotational speed depends on the equipment (see OPT 18).

18: DISP TMP NOMINAL

Displays the nominal frequency of the turbomolecular pump (revolutions per second), which varies within a certain range depending on the equipment.

Display: TM - PUMP NOM: xxx RPS

Also see OPT 17.

Note

The nominal value is also stated on the name plate of the pump.

19: DISP TESTLK TEMP

Displays once only the current temperature of the integrated calibrated leak (in °C).

Display: TESTLEAK TEPM: + xx C

20: DISP INT. TESTLK

Displays the leak rate of the integrated calibrated leak (mbar·l·s⁻¹).

Display: TESTLK: x.x E - yy ML/S

21: DISP SEL MASS NO

Displays the mass number to which the mass spectrometer is aligned.

Display: MASS: x u

Possible values for x are: 2, 3 or 4. Standard value is: 4 (helium).

22: DISP VERS. NO STE

Displays the number of the software version of the control processor.

Display: STE: VERSION x.xx

Note

- The first two digits of the software version number must be the same as for the communication processor (see OPT 23).
- To exchange the software see separate instructions „Exchanging the EPROMs in the helium leak detector ULTRATEST UL 500“.

23: DISP VERS. NO KOM

Displays the number of the software version of the communication processor.

Display: KOM: VERSION x.xx

Note

- The first two digits of the software version number must be the same as for the control processor (see OPT 22).
- To exchange the software see separate instructions „Exchanging the EPROMs in the helium leak detector ULTRATEST UL 500“.

24: TUNE? EXEC / CLR

This option performs the alignment of the acceleration voltage for the mass spectrometer, in order to

set the sensitivity to maximum for the programmed mass.

This process is performed in two stages.

Initially a coarse alignment is performed followed by fine tuning. This process can only be started from the STANDBY mode. Otherwise the following error message will occur:

NO TUNE IN DETECT

Note

The fine alignment for maximum is performed tuning each calibration process (with the exception of the first CAL after switching on; see also AUTOTUNE in Section 2.8.1).

25: ZERO? EXEC / CLR

This function performs the determination of the internal helium background in all measurement ranges. Thus ZERO expands the background resp. Zero determination in the FINE and PREC ranges each time the STOP cycle is run through.

The thus expanded values are taken into account during all further measurements for checking the leak rate.

This can only be done starting from the STANDBY mode. Otherwise the following error message will be displayed:

NO ZERO IN DETECT

Note

The background is determined each time the calibration process is run.

26: CAL EMV? EXEC / CLR

Determines the ratio between the output voltages of the high impedance amplifier for the 5 GΩ and 50 GΩ range as well as between the 50 GΩ and the 500 GΩ range.

By calculation of these factors it is possible to compensate resistance and thus gain errors between the measurement ranges during all further leak rate measurements.

The once determined values remain stored even in the case mains failure.

To perform the alignment a variable calibrated leak, range 1·10⁻⁵ mbar·l·s⁻¹ must be connected to the inlet (for example TL 4-6, Cat. No 155 80).

The UL 500 must be set to operate in the DETECT mode by pressing START. Otherwise the following error message will be displayed:

NO CALEMV IN STBY

The alphanumeric display provides further information for the user. As the leak rate of the calibrated leak must be within a certain range the following messages can occur:

SIGNAL TOO LOW

when the leak rate is too low

SIGNAL TOO HIGH

when the leak rate is too high.

The setting of the variable leak has to be changed until the message:

SIGNAL IN RANGE

is displayed. After this the setting of the calibrated leak may not be changed any more. The calibration process is then performed automatically.

The process can be terminated by pressing the „CLR“ key (7/4) and this is acknowledged briefly by the display of

CLEAR CALEMV

Note

As the resistance values change only slowly with time this alignment has to be carried out only very rarely. However it must be carried out after exchanging the amplifier or the EPROMs of the control processor.

27: SETTING EXT V.24

This permits the setting of the parameters of the optional V.24 / RS 232 C interface. See GA 10.292.

Note

- These settings can only be made with the interface pcb. built in. Its presence is automatically detected upon switching on the UL 500.
- If the interface pcb. is not sensed and when selecting OPT 27 the following error message is displayed:

NO EXT-V.24

2.2.20 „HELP“ Key

HELP

The „HELP“ key (7/1) has no meaning during normal operation.

2.2.21 „EXEC“ Key

EXEC

The „EXEC“ key (7/3) is used to start or acknowledge functions which have been initiated via other keys.

Acknowledgements of messages of the UL 500 can be input via the „EXEC“ key (7/3).

2.2.22 Volume Control

The volume of the acoustic signal can be adjusted with the volume control (6/1).

Turning the volume control up increases the volume, turning it down decreases it.

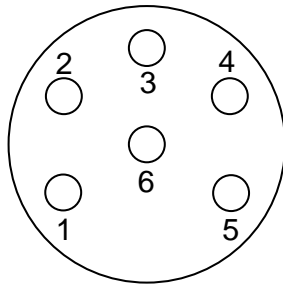

Fig. 11 Recorder output and remote control connection

Key to Fig. 11

| Pin | Function |
|-----|---|
| 1 | Channel 2 (exponent trigger voltage) / |
| 2 | +15 V supply voltage for remote control / |
| 3 | Analogue ground (for channel 1 and 2) / |
| 4 | Connection remote control START / STOP / |
| 5 | Channel 1 (measurement value lin. / log.) / |
| 6 | Ground (screen) / |

3.2.23 Recorder Output and Remote Control Connection Socket

The pin-out of the recorder output and remote control connection socket is given in Fig. 11.

The measurement data are output in analogue form, depending on the operating mode selected via OPT 11 to OPT 14. The following voltages are output (recorder with an input resistance exceeding 2.5 kΩ):

- | | |
|--|--|
| 1. Leak rate linear | 1.0 - 9.9 V per decade (channel 1 / Pin 5) |
| Leak rate exponent | 0.5 V per decade starting at 1 V at 10^{-10} mbar·l·s ⁻¹ (Channel 2 / Pin 1) |
| 2. Leak rate logarithmic | 0.5 V per decade starting at 1 V at 10^{-10} mbar·l·s ⁻¹ (Channel 1 / Pin 5) |
| 3. Inlet and forevacuum- pressure logarithmic | 0.5 V per decade starting at 1 V at 10^{-3} mbar (Channel 1 / Pin 5) |

The corresponding ground connection for channel 1 and channel 2 is the analogue ground pin 3.

Note

The output to the recorder is always in units of mbar·l·s⁻¹ resp. mbar. This is independent of the unit selected for the display.

The recorder output socket can additionally be used for the connection of a remote control unit through which is it possible to control the functions START and STOP / VENT.

Different voltages applied to the input (pin 4) provide the following functions.

- DC + 12.5 V to + 15 V: START
- DC 0 V to + 2.5 V for < 1.1 s : STOP
- DC 0 V to + 2.5 V for > 1.1 s : VENT

The + 15 V available at pin 2 can be used for the above purposes.

- Important**
- The voltage is not short-circuit proof.
 - The ground available at pin 6 (screen) must be used for the control inputs!

A suitable circuit is given in Fig. 12.

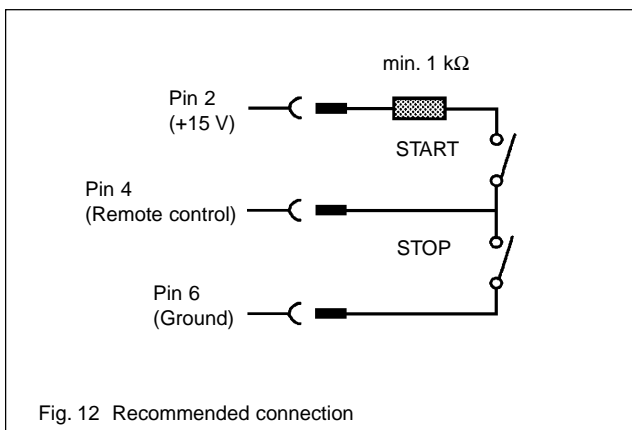

Fig. 12 Recommended connection

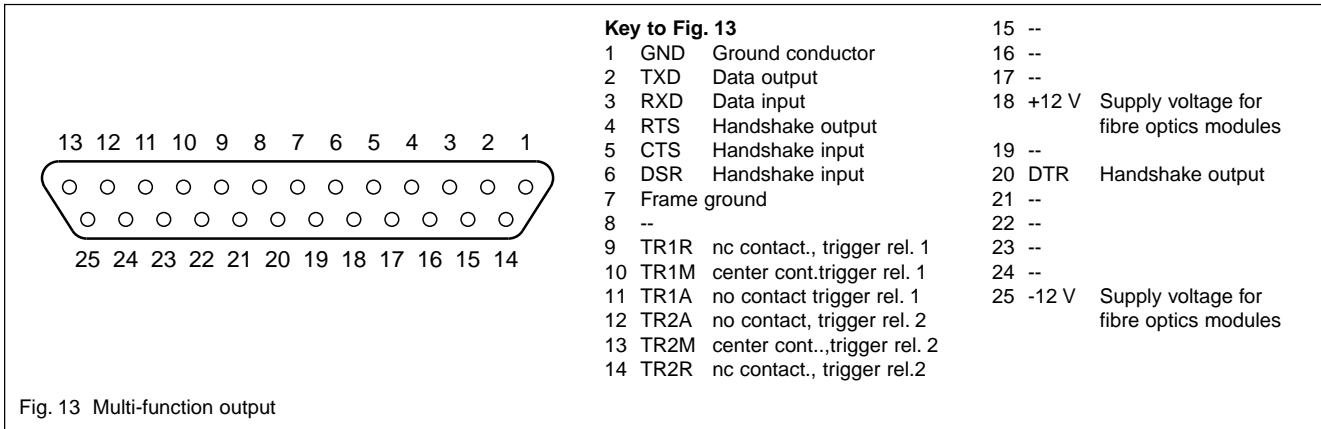

Fig. 13 Multifunction output

2.2.24 Pin-out of the Multifunction Socket

The multifunction socket is only operative with built-in V.24 / RS 232 C option and / or trigger option. Details are given in the corresponding operating instructions for these options.

- V.24 / RS 232 C interface (GA 10.292)
- Trigger relay pcb. (GA 10.291)

The pin-out of the multifunction socket is given in Fig. 13.

2.2.25 Headset Output

See Fig. 6 for the connection of a headset. The loudspeaker is switched off when connecting a headset. The volume of the headset signal is adjusted via the volume control (see Section 2.2.22).

2.3 Description of Displays

Note

For the following explanations see also fig. 8.

The displays of the UL 500 serve, on the one hand, to indicate the measured values generated by the unit and, on the other, to provide information on the operating modes that have been set and to inform the operator as to the measurement sequence and requirements.

The displays are divided into three main groups:

- Measured-value displays as analog and digital displays,
 - Status displays,
 - General-purpose alphanumeric display.
- In addition there is available as a further „display“ function an
- Acoustic signal.

2.3.1 Analog Display

The primary function of the analog display of the UL 500 is to indicate the trend of the measured values for the leak rate quickly and clearly during leak detection.

The circular display (8/1) composed of 45 individual segments shows the measured leak rate in a quasi-analog form via a rotating illuminated indicator. Clockwise revolution means a rising leak rate, and counterclockwise revolution a falling one. It is therefore easily possible to localize the maximum leak rate by observing the direction in which the indicator is moving, which facilitates leak detection especially when great distances are involved with test objects.

In the equipment operating mode INSPECT the leak rate is shown only on the circular display (8/1). Depending on the operating mode selected for the display, there are two different types of representation on the circular display. The exponent associated with the measured value is displayed on the bar scale (8/2) beside it. Here one panel with the exponent number lights up in each case.

If no limit or only the low limit (see Section 2.2.18) has been activated to restrict the measuring range of the UL 500, the circular display is in the normal operating mode.

This means that the leak rate measuring range is shown in decades on the circular display. One revolution of the indicator corresponds to one decade of the measured value from 1.0 to 9.9. The starting point of each decade at 1.0 is identified by a constantly illuminated line at the bottom of the circular display.

The display within each decade is in logarithmic form, thus permitting a more uniform representation when measured values are changing rapidly.

2.3.1.1 Analog Display in Conjunction with „LIMIT LOW / LIMIT HIGH“ Functions

The analog display range is limited by entering a low and a high limit value (see Section 2.2.18).

If both limit values of the measuring range are activated, the measuring interval thus defined is no longer indicated by several revolutions of the indicator. The entire interval is shown on a sector of the circular display limited by two arrow-like markers (8/15) which light up next to the limit-value indicators on the circular display.

The indicated interval always consists of entire measured value decades, with the measured value being indicated in logarithmic form within this interval.

2.3.2 Digital Display

In the MEASURE mode, the measured value for the leak rate is shown on the analog display and also quantitatively as a number.

The digital display (8/3) provides a two-digit representation of the mantissa of the measured value and a two-digit number for the exponent.

„u“ or „o“ may appear in addition at certain measured values before the displayed number.

Here the „u“ means that the real measured value is below the displayed one (underflow). This happens at the lowest levels of the measuring ranges and in case of running below an adjusted low limit (LIMIT LOW).

The „o“ means that the real measured value is above the displayed one (overflow), which occurs in case of exceeding an adjusted upper limit.

The display of the valid measurement unit (8/4) or (8/5) accompanies the digital display.

In the VACUUM mode, the leak rate units can be selected (see Section 2.2.2.1).

In the SNIFF mode, the display appears as leak rate or as concentration in ppm, depending on whether RATE or CONC was chosen. The representation of the numbers varies, depending on whether the ACTUAL or MAXIMUM function was selected (see Section 2.2.10).

2.3.2.1 Digital Display in Conjunction with „ACTUAL“ Function

The digital display always indicates the current measured value. This corresponds to the one shown on the analog display.

2.3.2.2 Digital Display in Conjunction with „MAXIMUM“ Function

The digital display shows the maximum leak rate value which has occurred during the measurement cycle initiated with the „START / RESET“ „MAX“ key (7/15). It is reset by again pressing „START / RESET“ „MAX“ or by pressing the „STOP / VENT“ key (7/14).

2.3.3 Limit Value Display (Low and High Limits)

Two displays with digits (8/14) and (8/16) are located below the circular display so that the high and low limits can be entered and checked. The left panel shows the value of the low limit, and the right panel that of the high limit. The representation of the panels corresponds to that of the digital display of measured values (8/3).

A two-digit mantissa of the measured value and a two-digit exponent with sign are displayed. The relationship to the analog display is explained in Section 2.3.1.

2.3.4 Status Displays

The status displays, which are of different colors, are used to indicate visually the functions that have been set.

- | | |
|------------------|---|
| Yellow displays: | Display statuses |
| Orange displays: | Equipment statuses related to the vacuum system |
| Red displays: | Warnings |

2.3.4.1 Description of Status Displays

FAST / SLOW

The FAST display (8/7) lights up when the measured-value display is set to react rapidly. The SLOW display (8/7) lights up when the measured-value display is set for greater damping.

MAX / ACT

The MAX display (8/6) lights up as a checkback signal when the function „Retain the last maximum“ has been set.

The ACT display (8/6) lights up as a checkback signal when the function „Display the currently measured value“ has been set.

BACKGRND

This display (8/12) lights up (red) when the measured value is not the absolute leak rate but when a helium background was suppressed by operating the „ZERO“ key (Section 2.2.6).

SNIFF / VAC

The SNIFF and VAC displays (8/10) respond as follows to a change in the operating mode:

- The display indicating the previous operating mode remains lit; the display for the newly selected mode flashes.
- If the „EXEC“ key is pressed, the display stops flashing and becomes steady, while the other is switched off.

STOP / VENT

The STOP and VENT displays (8/9) indicate the mode which the unit is in after the „STOP / VENT“ key (7/14) has been actuated for a short or long time (see Fig. 14).

In the STANDBY mode of the UL 500, STOP lights up; in the VENTED mode, VENT always lights up as well.

PREC

The PREC display (8/11) identifies the expanded AUTORANGE.

Pressing the „PREC“ key (7/12) causes the PREC display (8/11) to start flashing. A request appears in the alphanumeric display line that the activation or deactivation of the PRECISION range will be acknowledged by pressing the „EXEC“ key (7/3).

CAL

The CAL display (8/13) signals three statuses:

Deactivated:

- Always in the INSPECT mode.
- While the unit is warming up; during this phase, calibration is not feasible.
- In the MEASURE mode, with the unit warmed up and calibration already performed.

Flashing:

As the initial request to perform calibration when the warm-up phase is over (15 min approx.) and the unit has been or is being switched to the MEASURE mode. This is skipped if a calibration was performed during this time.

Steady light:

Further requests to perform calibration whenever the control processor considers this necessary owing to temperature-related drifting (± 5 °C) after prolonged periods of operation.

CAT 2

The ion source of the UL 500 is equipped with two cathodes. As soon as the cathode 1 normally used malfunctions, automatic switchover to cathode 2 occurs.

The red CAT 2 warning display (8/8) informs the operator that switchover has taken place, because failure of cathode 2 would then result in the failure of the entire unit.

2.3.5 Alphanumeric Display

Any desired text can be shown in the alphanumeric display line (8/17) to support the operator in using the UL 500. The following can be displayed:

- Specific measured values, e.g. inlet or foreline pressure.
- Notes in the event of operator errors or illegal entries. The notes appear on the alphanumeric display for approx. 2 s; thereafter the normal display returns.
- Requests for certain activities to be executed.
- Error messages in the event of malfunctions, see Section 2.9. The error messages remain in the display until they are cleared by pressing the „EXEC“ key (7/3).

2.3.6 Acoustic Signal

The acoustic signal is used to indicate the leak rate. Its frequency is a measure of the leak rate value. The entire measuring range shown on the analog display is represented by a frequency range of approximately 60 Hz to 4 kHz.

The volume can be varied via a volume control (6/1).

2.4 Startup (First Pumpdown Cycle)

| Step | Activity | Response | Displayed text |
|------|---|--|---|
| 1 | Close connecting flange (5/5) with blind flange | -- | |
| 2 | Set power switch (5/1) to ON | <p>Start of automatic self test;</p> <p>Visual check of microprocessor modules;</p> <p>Visual check of status displays on display unit (Fig. 8)</p> <p>Activation of auxiliary pump and forepump</p> <p>Start of automatic runup of turbomolecular pump (up to 4 min)</p> <p>Alternate display of turbomolecular pump speed and fore vacuum pressure p_2</p> <p>Tuning of mass spectrometer to maximum sensitivity for helium</p> <p>Determination of electric offset voltage and helium background to correct the measured values</p> <p>Status display STOP on display unit lights up</p> | <p>LEYBOLD VACUUM UL 500 VERSION x.x PERFORMING SELFTEST</p> <p>ROM CHECK OK RAM TEST OK</p> <p>PERFORMING LCD-TEST</p> <p>SELFTEST: NO ERRORS RUNNING UP</p> <p>TM-PUMP ACT: xxx RPS P2: x.xE-yy mbar</p> <p>SENSITIVITY CHECK PERFORMING AUTOZERO</p> <p>STANDBY FOR (INSP)</p> |
| 3 | Press „START“ key (7/15) briefly | <p>Initiation of measurement procedure (pumpdown of dead volume at the inlet)</p> <p>Deactivation of status display STOP</p> <p>Display of leak rate on analog display</p> | <p>PREPARING (DETECT)</p> <p>DETECTING (INSP)</p> |
| 4 | Press „STOP“ key (7/4) for more than 1.1 s | <p>Initiation of STOP procedure</p> <p>Activation of status display STOP</p> <p>Display of detection limit</p> <p>Initiation of venting procedure</p> <p>Vent valve opens after approx. 1.1 s</p> <p>Activation of status display VENT</p> | <p>PREPARING (STOP)</p> <p>STANDBY FOR (INSP)</p> <p>PREPARING (VENT)</p> <p>STANDBY FOR (INSP)</p> |
| 5 | Open connecting flange (5/5) | -- | |
| 6 | Connect test object | -- | |
| 7 | Press „START“ key (7/15) briefly | <p>Initiation of measurement procedure (pumpdown)</p> <p>Deactivation of status displays STOP and VENT</p> | <p>PREPARING (DETECT)</p> <p>DETECTING (INSP)</p> |
| 8 | Spray test object with helium | Display of leak rate on analog display | |
| 9 | Press „STOP / VENT“ key for more than 1.1 s | <p>Initiation of STOP procedure</p> <p>Activation of status display STOP</p> <p>Display of detection limit</p> <p>Initiation of venting procedure</p> <p>Vent valve opens after approx. 1.1 s</p> <p>Activation of status display VENT</p> | <p>PREPARING (STOP)</p> <p>STANDBY FOR (INSP)</p> <p>PREPARING (VENT)</p> <p>STANDBY FOR (INSP)</p> |
| 10 | Disconnect test object | -- | |

2.5 Operating Modes

The standard UL 500 is equipped for two basic operating modes: vacuum mode (VAC) and sniffing mode (SNIFF).

In each of these modes, the UL 500 can operate in the inspection mode (INSP) or measurement mode (MEAS). See Fig. 14.

2.5.1 Vacuum Mode (VAC)

In the VAC mode, a test object is flanged to the inlet of the UL 500 and evacuated by pressing the „START“ key. The pressure in the test object may vary between 1000 mbar and less than 10^{-3} mbar. When the evacuated test object is sprayed with helium, helium can enter the test object through any existing leak, owing to the pressure difference. The helium reaches the mass spectrometer where the gas molecules are ionized and detected.

Qualitative leak detection is possible as soon as pumping is started.

Note

If the ambient air is found to be enriched with helium carry out one of the following measures:

- Connect hoses to the exhaust lines at the rear of the UL 500 (9/6 and 9/7) and lead them to helium-free air.
- Feed-in fresh air through a hose connected to venting valve VF1 (2/15).

2.5.1.1 Local Leak Detection in the Vacuum Mode

For local leak detection, the test object (15/2) connected to the UL 500 must be sprayed with helium at the points where leaks are suspected. If possible, use a spray gun with a fine nozzle (15/4).

In order to detect very small leaks next to leaks already discovered on the test object, the latter must be sealed by coating them with alcohol or by preventing the access of helium by screening the leak. See Fig. 15.

In the case of systems with pumps of their own, check the sensitivity of the entire system with a calibrated leak. Because of the additional pumps the UL 500 measures only a partial flow of the total leak rate, i.e. the detection limit will now be above $2 \cdot 10^{-10}$ mbar·l·s⁻¹.

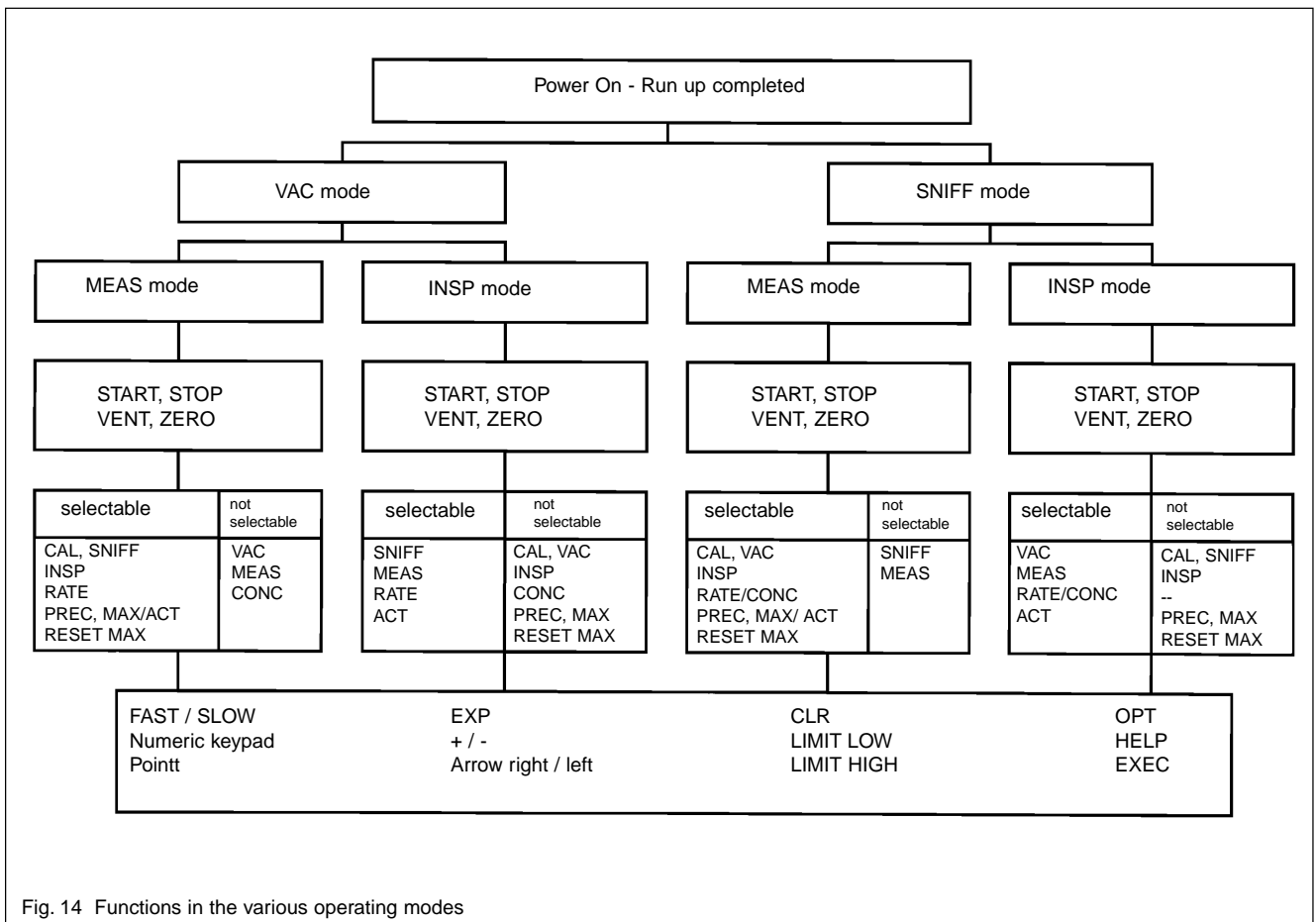

Fig. 14 Functions in the various operating modes

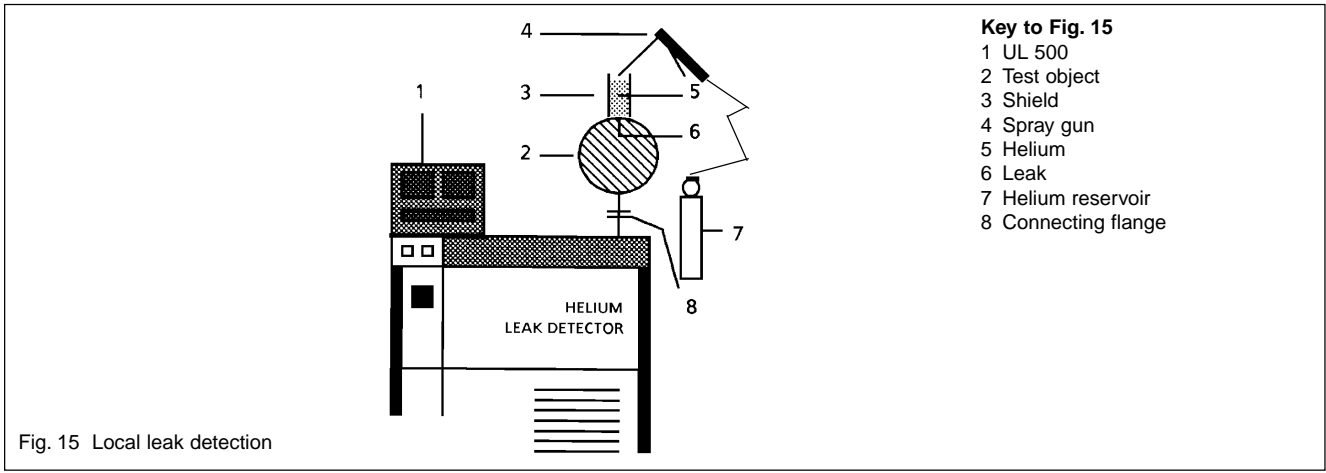

Fig. 15 Local leak detection

A calibration may be performed with an external calibrated leak by pressing the „CAL“ key even in the case of high partial flow ratios (Section 2.7.1.2).

The response time is also determined with a calibrated leak. To do this, a calibrated leak is connected to the test object at the point furthest away from the test connection. The leak rate indicated by the UL 500 is the leak rate of the calibrated leak. The calibrated leak is closed, and simultaneously the time is measured until the leak rate indicated by the UL 500 has dropped to about 37 % of the original value. The time thus recorded is the response time.

During quantitative local leak detection helium has to be sprayed onto the leak at least as long as the response time. Otherwise the displayed value may lie considerably below the actual leak rate.

2.5.1.2 Integral Leak Detection in the Vacuum Mode

For integral leak detection, the test object (16/2) is enclosed in a hood (16/3), e.g. a PVC bag, filled with a known helium concentration (16/4). If possible, the connecting flange (16/6) should not be surrounded by the hood, since helium might diffuse through the connec-

ting gasket and cause a background.

The test time should be kept as short as possible for integral leak detection. If it is too long, the test object may become contaminated (see Fig. 16).

Note

In the case of very large leaks (for example by sudden damage to the test sample) there is a risk of helium contamination of the foreline pumps, leading to an erratic background signal thus preventing sensitive measurements. In such a case the following error message is displayed:

BACKGROUND TOO HIGH
OPEN GASBALLAST

Measures:

- Set LIMIT LOW to a higher value so that the background is no longer displayed (provided only large leaks are of interest).
 - Open the gas ballast on both pumps so that helium-free air may enter. Electromagnetically actuated gas ballast valves are available as accessories for this. They can be actuated through OPT 05.
- If option 05 has not been implemented it is possible to manually open the gas ballast on the pump (18/5) and

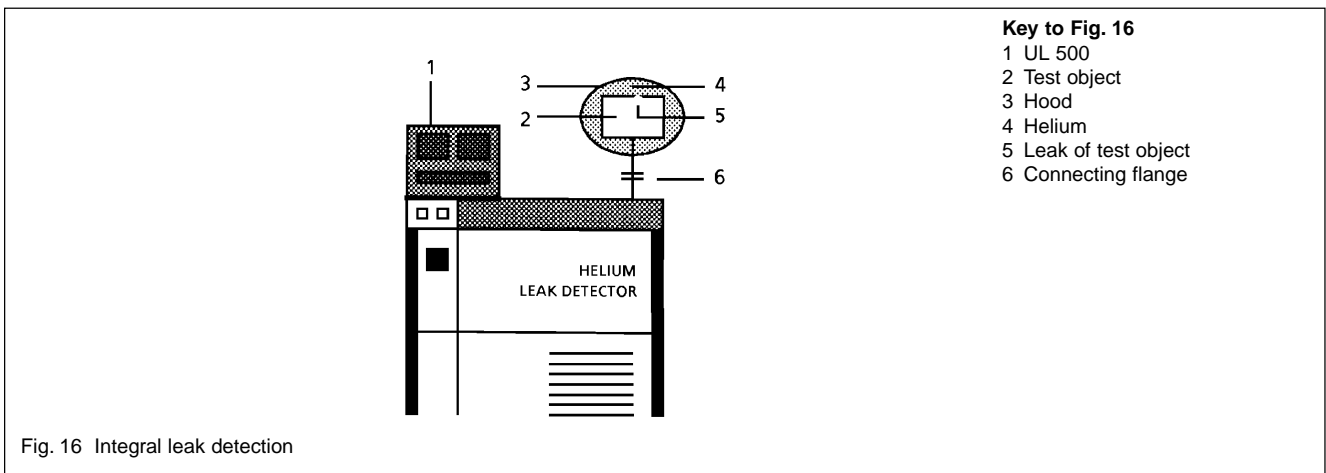

Fig. 16 Integral leak detection

(18/6). Take care that the ambient air is not contaminated with helium!

2.5.2 SNIFF Mode

In this basic operating mode, leak detection on a test object filled with helium at overpressure is possible. For this purpose, a standard or QUICKTEST sniffer is connected to the inlet of the UL 500.

If there is a leak in the helium-filled test object, helium is forced out by the overpressure and can be sucked in by the UL 500 via the sniffer.

Helium thus reaches the mass spectrometer, where the gas molecules are ionized and detected. In the SNIFF mode, quantitative determination of the leak rate is also possible.

The main difference between the SNIFF and VAC modes are the calibration possibilities of the former.

2.5.2.1 Local Leak Detection in the SNIFF Mode

For local leak detection in the SNIFF mode, a test object filled with helium is scanned locally with the sniffer probe to find any leaks.

The actual leak rate of the test object can only be displayed after calibration under defined sniffing conditions.

The calibration factor for the UL 500 can be determined through the CAL function in the SNIFF (MEAS) mode.

To do this press the following keys:

„SNIFF“, „MEAS“, „RATE“, „FAST“

See Section 2.7 for details on this calibration.

The calibration only applies for the position of the sniffer tip used for the calibration. Correction of leak rate to standard leak rates (100 % He, 1 bar to 0 bar) see Section 2.5.2.3.

Preparations for determining the actual leak rate:

Press the following keys :

„SNIFF“, „MEAS“, „RATE“, „MAX“ and „FAST“.

The calibration factor is calculated on the UL 500 by the calibration function in the SNIFF mode (MEAS).

Determination of the actual leak of a test object:

The test object must be scanned with the same sniffing speed and the same sniffing distance as was used for the calibration procedure.

With calibration completed, the actual leak rate is then displayed on the UL 500.

Note

If the test object is not filled with 100 % helium, the actual leak rate obtained on the test object (Q_{LEAK}) must be cor-

rected using a helium concentration factor in order to obtain the true leak rate.

2.5.2.2 Integral Leak Detection in the SNIFF Mode

For integral leak detection in the SNIFF mode, the helium-filled test object is placed in a sealed hood. If there are one or more leaks, helium gradually flows into the hood where it enriches slowly. To measure the rise in the helium concentration in the hood, the sniffer tip is introduced into the hood at the end of the waiting period.

After appropriate concentration calibration (see Section 2.7) for example with air helium, the UL 500 directly displays the helium concentration.

Preparations for determining the actual leak rate:

Press the following keys on the UL 500:

„SNIFF“, „MEAS“, „CONC“, „ACT“ and „SLOW“.

To determine the actual leak rate (Q_{LEAK}), the air-helium concentration (Q_L) is first measured with the UL 500 and set to zero with the aid of the „ZERO“ key.

Then, using a thick PVC foil, a sealed volume is established around the point to be tested, and the actual hood volume is established.

Note

An error in estimating the hood volume has a linear effect on the leak rate determination, i.e. percentage error in volume = percentage error in leak rate.

After an adequate waiting period (Δt), the sniffer is introduced into the hood and the finally displayed value (ΔC_{HE}) is recorded.

Calculation of the actual leak rate (Q_{LEAK}):

Data needed:

V_H hood volume in liters

P_O atmospheric pressure in mbar

t waiting time in seconds

ΔC_{HE} change in helium concentration in hood

Note

The displayed change in concentration is only correct if the initial value (air-helium concentration) was set to zero with the ZERO key.

$$Q_{LEAK} = \frac{V_H \cdot P_O \cdot C_{HE}}{\Delta t} \quad [1]$$

Note

The determined leak rate of the test object is only valid for the parameters prevailing during the test. Other leak rates are obtained if the pressure differential, type of gas, temperature or liquid charge changes. If the test object is not filled with a 100 % helium concentration, the leak rate must also be corrected with a helium concentration factor.

2.5.2.3 Calculation of Standard Leak Rate as a Function of Pressure Differential

The leak rate obtained must be converted to arrive at the standard leak rate Q_0^N .

This is the helium flow in $\text{mbar}\cdot\text{l}\cdot\text{s}^{-1}$, that passes through the leak in the case of 100 % helium in front of the leak and a pressure differential of 1 bar vs. 0 bar.

If the test sample is not filled with 100 % helium but with x % helium the following correction has to be made:

$$Q_{\text{corr}} = (Q_{\text{meas}} / x) \cdot 100$$

With Q_{corr} it is then possible to carry out the following correction for higher pressures in the test sample. In the following Q_{corr} is abbreviated by Q ; the standard leak rate to be determined (100 % He, 1 bar \rightarrow 0 bar) is termed Q_0 .

The calculation given below permits conversion of the measured leak rate (at the true pressure differential) into the leak rate at 1 bar helium pressure in front of the leak and 0 bar pressure behind it. This leak rate is termed Q_0 . In the laminar flow region, the leak rate is a square function of the pressure differential.

$$Q (P_1 \rightarrow P_2) = Q_0 (P_1^2 - P_2^2) \quad (1)$$

- Q measured leak rate
- P_1 absolute pressure in test object
- P_2 atmospheric pressure = 1 bar
- Q_0 leak rate at 1 bar helium vs. 0 bar

Rearranging Eq. (1) results in:

$$Q_0 = \frac{Q_{\text{Korr}}}{P_1^2 - P_2^2} \quad [2]$$

and with $p_2 = 1$ bar

$$Q_0 = \frac{Q_{\text{Korr}}}{P_1^2 - 1} \quad (P_1 \text{ in bar}) \quad [3]$$

2.5.3 „INSPECT“ Mode

The INSPECT mode can be selected in both the VAC and SNIFF modes.

In the INSPECT mode, the operator of the UL 500 is able to locate leaks as soon as the STANDBY message appears.

In this mode, the analog display permits precise localization of the leak; the digital leak rate display is deactivated.

Note

It is not necessary to calibrate the UL 500. (For quantitative leak detection, the MEASURE mode has to be selected.)

2.5.4 „MEASURE“ Mode

In this case, too, leak detection is possible as soon as the STANDBY message appears. The MEASURE mode can be performed in both the VAC and SNIFF modes.

The operator can activate the integrated CAL function of the UL 500 at any time. Then leaks can be quantitatively determined between $10 \text{ mbar}\cdot\text{l}\cdot\text{s}^{-1}$ and $2 \cdot 10^{-10} \text{ mbar}\cdot\text{l}\cdot\text{s}^{-1}$ in the VAC mode (in the SNIFF mode, this is dependent on the sniffing parameters, up to $10^{-6} \text{ mbar}\cdot\text{l}\cdot\text{s}^{-1}$).

It is possible to display the maximum value on the digital display in order to read the precise leak rates during local leak detection (see 2.2.10.1 and 2.2.10.2.).

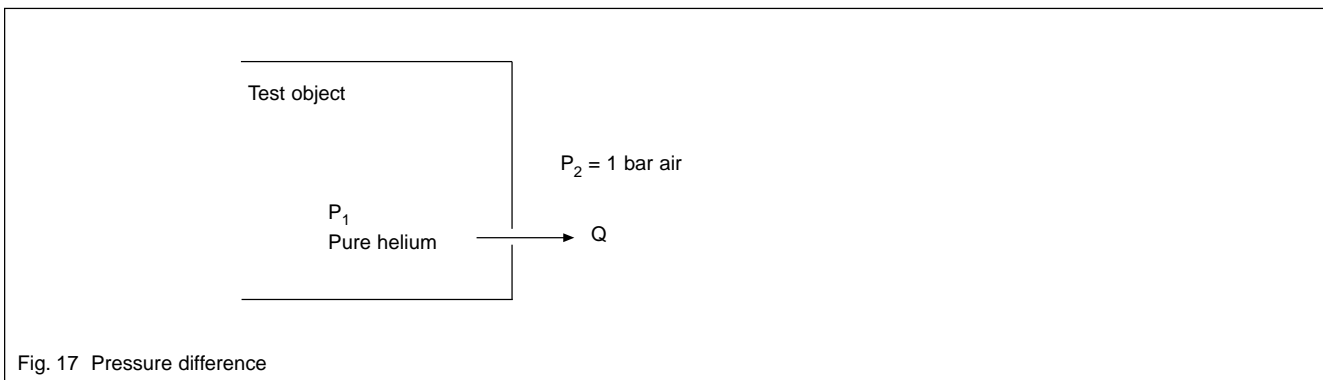

Fig. 17 Pressure difference

2.6 Shutdown

To put the UL 500 out of operation, set the main switch (5/1) to „OFF“. No further action is necessary.

The operating mode of the UL 500 is stored in a battery backed-up memory when switching off, so that the same operating mode is set up automatically when switching on again (see also Section 2.2.1).

2.7 Calibration

2.7.1 Calibration in the Vacuum Mode

In the vacuum mode (VAC), the UL 500 can be calibrated with its integrated calibrated leak or with an external calibrated leak mounted directly at the test connection.

Note

If the UL 500 is connected to a vacuum system, external calibration must be performed with a calibrated leak mounted at the furthest point of the vacuum system.

2.7.1.1 Calibration with Internal Calibrated Leak

For leak testing of components a calibration with the integrated helium test leak is normally initiated by pressing the „CAL“ key (see Section 2.2.7). It can only be performed in the STANDBY status. Then the UL 500 automatically controls the subsequent operations.

These are:

- Measurement of Zero,
- Measurement of actual value (opening and closing of the calibrated leak),
- Calculation of calibration factor.

Initiation of internal calibration:

- Press „STOP“ key
- Press „CAL“ key
- Press „EXEC“ key

Termination of internal calibration:

- Press „CLR“ key.

2.7.1.2 Calibration with External Calibrated Leak

In order to take proper account of the influence of the test object's pressure and possible pressure conditions in partial-flow operation, calibration with an external calibrated leak is required. The use of calibrated leaks is permissible which produce a reading between $8 \cdot 10^{-9}$ and $9.9 \cdot 10^{-4}$.

Note

If the volume flow rate of the vacuum system is high the real leak rates of the calibrated leaks must be considerably higher in order to produce a useful reading.

For an external calibration it is important that the UL 500 is in the DETECT mode (see also „CAL“ key in Section 2.2.7).

The external calibration process is prepared by connection of an external calibrated leak to the system or the test samples.

Starting the process:

- Press „START“ and after pumpdown wait for the „DETECTING“ message
- Press „CAL“ key (7/16)
- Press „EXEC“ key (7/3).

The running process may be terminated by pressing the „CLR“ key (7/4).

After starting, messages appear on the alphanumeric display line (8/17) informing the operator of the sequence and requesting him to perform further operations.

CAL EXT. ? : EXEC / CLR

Press „EXEC“ key (7/3).

EXT. TLK ? = x.xE-xx

Enter leak rate of the calibrated leak.

Press „EXEC“ key (7/3).

OPEN TESTLEAK ! EXEC

Open calibrated leak, acknowledge by pressing „EXEC“.

SIGNAL STABLE ? EXEC

Wait until the signal is stable, then press „EXEC“ key (7/3).

CLOSE TESTLEAK ! EXEC

Close calibrated leak, then press „EXEC“ key.

SIGNAL STABLE ? EXEC

Wait until the signal is stable, then press „EXEC“ key (7/3).

The UL 500 automatically determines the calibration factor for the leak rate measurement, followed by the message:

CALIBRATION FINISHED

The instrument is now ready for further measurements. The „CLR“ key can be used to erase this message.

Note

In order to determine the calibration factor a minimum difference in the leak rate signal is required between opened and closed calibrated leak. If this difference is too small the following error message occurs:

ER : CAL - DIFFERENCE <<

In such a case select PREC and repeat the calibration!

2.7.2 Calibration in the SNIFF Mode

In the SNIFF mode the UL 500 can only be calibrated externally. However it is possible to perform this calibration for concentrations (ppm) and leak rates ($\text{mbar}\cdot\text{l}\cdot\text{s}^{-1}$). For the calibration the UL 500 must be in the DETECT mode with the sniffer connected (Press „START“ key).

Note

In order to obtain the highest possible sensitivity the UL 500 should be set to the PREC mode.

2.7.2.1 Calibration with a Known Helium Concentration

Range 5 ppm to $9.9\cdot 10^3$ ppm.

In the simplest case the calibration is carried out with air helium (5 ppm). This air must not be contaminated by helium, i.e. helium must not have been sprayed in the vicinity.

If considerably higher concentrations are to be measured later on it is advisable to produce a corresponding known helium concentration in a bag.

Special bags with an aluminium coating are used for this purpose. Initially the bag is filled with pure inert gas (e.g. Ar, N₂) and helium is filled in using a syringe.

Both the amount of inert gas and helium have to be known precisely. It is only then possible to calculate the concentration.

Switch the UL 500 to „CONC“ with the key „RATE/CONC“. The display is now in ppm.

Starting the calibration:

- Press „START“ key; after pumpdown wait for the message „DETECTING“.
- Press „CAL“ key.
- Press „EXEC“ key.

The running process may be terminated by pressing the „CLR“ key.

After starting, messages appear on the alphanumeric display line (8/17) informing the operator of the sequence and requesting him to perform further operations.

CAL EXT. ? : EXEC / CLR

Press „EXEC“ (7/3) key.

CONC [PPM] ? = x.xE-xx

Enter the test concentration (e.g. 5 ppm = 5.0E-00).

Press „EXEC“ (7/3) key.

SNIFF CONC ! EXEC

Hold the sniffer tip into the gas with the known helium concentration (e.g. air), then press „EXEC“ (7/3) key.

SIGNAL STABLE ? EXEC

Wait until the signal is stable, then press „EXEC“ key (7/3).

The UL 500 automatically determines the calibration factor for the concentration measurements based on the determined concentration and the last available value of the internal Zero.

This is followed by the message:

CALIBRATION FINISHED

The instrument is now ready for further measurements. The „CLR“ key can be used to erase this message.

Note

In order to determine the calibration factor a minimum difference between signal and Zero is required. If this difference is too small the following error message occurs:

ER : CAL - DIFFERENCE <<

In such a case select PREC and repeat the calibration!

2.7.2.2 Calibration of Helium Leak Rate

Range $1\cdot 10^{-6}$ to $9.9\cdot 10^{-4}$ $\text{mbar}\cdot\text{l}\cdot\text{s}^{-1}$.

The calibration of the helium leak rate requires a sniffer calibrated leak (e.g. Cat. No. 155 88, TL 4-6) (a sample of a faulty component filled with helium may also be used for comparative purposes!).

After having entered the set point leak rate and unscrewing the blocking valve at the leak (the leak is then directly accessible) proceed as follows:

Switch the UL 500 to „RATE“ with the key „RATE / CONC“.

The displayed values will then be in the unit whichever was preselected.

Starting the calibration:

- Press „START“ key; after pumpdown wait for the message „DETECTING“ .
- Press „CAL“ key.
- Press „EXEC“ key.

The running process may be terminated by pressing the „CLR“ key .

After starting, messages appear on the alphanumeric display line (8/17) informing the operator of the sequence and requesting him to perform further operations.

CAL EXT. ? : EXEC / CLR

Press „EXEC“ (7/3) key.

EXT. TLK ? = x.xE-xx

Enter the leak rate of the calibrated leak and then press the „EXEC“ key.

SNIFF TESTLEAK ! EXEC

Hold the sniffer tip at a defined distance from the calibrated leak and then press the „EXEC“ key.

SIGNAL STABLE ? EXEC

Wait until the signal is stable, then press „EXEC“ key (7/3).

SMELL AIR ! EXEC

Hold the sniffer tip in uncontaminated air, then press EXEC key (7/3).

SIGNAL STABLE ? EXEC

Wait until the signal is stable, then press „EXEC“ key (7/3).

The UL 500 automatically determines the calibration factor for the leak rate measurement, followed by:

CALIBRATION FINISHED

The instrument is now ready for further measurements. The „CLR“ key can be used to erase this message.

Note

In order to determine the calibration factor a minimum difference in the signal between cal. leak and air is required. If too small the following error message occurs:

ER : CAL - DIFFERENCE <<

In such a case select PREC and repeat the calibration.

2.8 Automatic Functions

The UL 500 has three automatically executed functions which ensure that the displayed measured values are correct.

2.8.1 AUTOTUNE

This function automatically aligns the mass spectrometer to the maximum leak rate display. For this purpose, the UL 500 uses the internal, helium-filled calibrated leak. The control processor varies the accelerating voltage of the ions in the selected mass range until a maximum ion current is registered on the ion collector.

This is done in two steps: Coarse and fine alignment (see OPT 24).

A fine alignment is performed automatically before each calibration.

2.8.2 AUTOZERO

This function is employed to define the unit's internal Zero for the leak rate signal in order to prevent the display of the internal helium background and offset voltages as measured values.

This function is carried out automatically each time the UL 500 is switched from DETECT to STANDBY by pressing the „STOP“ key. (See also the function of the key „STOP / VENT“.)

The value of the helium signal is measured in the ranges FINE 3 and PREC and the measured values are stored as „Zero references“. Each further measured leak rate value is corrected by the applicable offset value.

If negative leak rate values are produced through this correction all stored offset values are changed so that the smallest value will be Zero. Thus the values are automatically adapted to a gradually decreasing background.

If the helium background increases this cannot be automatically sensed. This increase is only considered after a transition from DETECT to STANDBY.

2.8.3 AUTORANGE

The UL 500 possesses an automatic measuring-range selection, which covers the entire leak rate range from 10^3 to $2 \cdot 10^{-10}$ mbar·l·s⁻¹. Not only the leak rate signal but also the test-object and mass-spectrometer pressure are used for control. The measuring ranges are switched over as follows:

- Main switchover to the main ranges MASSIVE, GROSS, FINE and PREC by means of valve switchover.

MASSIVE Display limit $1 \cdot 10^{-1}$ mbar·l·s⁻¹

| | |
|-------|---|
| | if $p_1 > 100$ mbar |
| | valve position: V _H open |
| GROSS | Display limit $5 \cdot 10^{-5}$ mbar·l·s ⁻¹ |
| | if $p_1 > 0.1$ mbar |
| | valve position: V _H , V _B open |
| FINE | Display limit $1 \cdot 10^{-9}$ mbar·l·s ⁻¹ |
| | if $p_2 > 2 \cdot 10^{-2}$ mbar |
| | or not PREC |
| | valve position: V _E , V _K open |
| PREC= | Display limit $2 \cdot 10^{-10}$ mbar·l·s ⁻¹ |
| | Valve: V _E open |

- Fine range switching within the main ranges by switching of the resistors within the amplifier.

Note

- If there is a lot of gas and thus a high pressure p_1 at the inlet flange it may be impossible to switch to a higher sensitivity despite of a low helium signal. This can occur for the transition MASSIVE 1 to GROSS 1 when p_1 exceeds 100 mbar, for the transition GROSS 2 to FINE 1 when p_1 exceeds 0.1 mbar and for the transition FINE 3 to PREC when p_2 exceeds $2 \cdot 10^{-2}$ mbar.
- The AUTORANGE process can be limited by setting of LIMIT LOW and LIMIT HIGH. This permits manual ranging by the user. See Section 2.2.18.3.

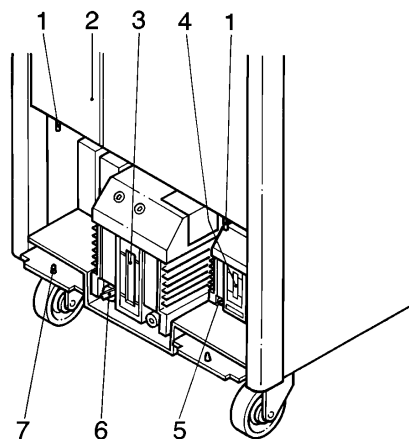

Key to Fig. 18

- 1 Guide pins for bottom front panel
- 2 Top front panel
- 3 Oil-level glass of auxiliary pump
- 4 Oil-level glass of forepump
- 5 Gas ballast switch of forepump (in zero position)
- 6 Gas ballast switch of auxiliary pump (in zero position)
- 7 Bottom support cam

Fig. 18 Oil-level glasses of the auxiliary pump and forepump

3 Maintenance

3.1 Checking the Oil Level and Gas Ballast Switch of the Auxiliary Pump or Forepump

Swing down the top front panel (18/4) into a horizontal position.

Raise the bottom front panel vertically until it can be pulled forward at its bottom edge and lifted off the two support cams (18/7).

Then pull it forward and down out of two guide pins (18/1) mounted on the center cross-strut.

The auxiliary pump and the forepump are now freely accessible.

The oil level must be visible between the two marks on the oil-level glasses (18/3) and (18/4). If necessary, refill the adequate oil (see Operating Instructions GA 01.201 or GA 01.202). A required oil change must be carried out as to the a.-m. operating instructions. In addition, both gas ballast switches (18/5) and (18/6) must be to the right, in the zero position.

After the check, remount the bottom front panel in the reverse order.

Note

Make sure that the bottom front panel is locked home in a vertical position in the bottom support cam (18/7).

3.2 Exchanging the Fluorescent Tube Behind the Display

Exchanging the fluorescent tube (life 1000 to 2000 operating hours) behind the display should be left to the LEYBOLD service as the display can easily be damaged in the process. The exchange must be carried out closely following the service instructions (SA 10.204).

3.3 Changing the Fuses on the Power Distribution (LV) Front Panel

The fuses are located on the lefthand plug-in (LV assembly, behind the upper front panel (see Fig. 19).

The fuses are assigned as follows:

| | | |
|-----|-------|-----------------------------------|
| S4 | T 4 A | Pump PV |
| S5 | T 1 A | Compressor motor |
| S6 | T 2 A | Ventilator |
| S7 | T 1 A | QUICKTEST connection (Plug ST 40) |
| S8 | T 2 A | Spare |
| S9 | T 1 A | Spare |
| S10 | T 2 A | VP 2 (+24 V) valves |

Key to Fig. 19

- 1 QUICKTEST connection socket (220 V)
- 2 Reset pushbutton for error messages
- 3 Seven segment error message display
- 4 Front panel
- 5 Power distribution assembly (LV)

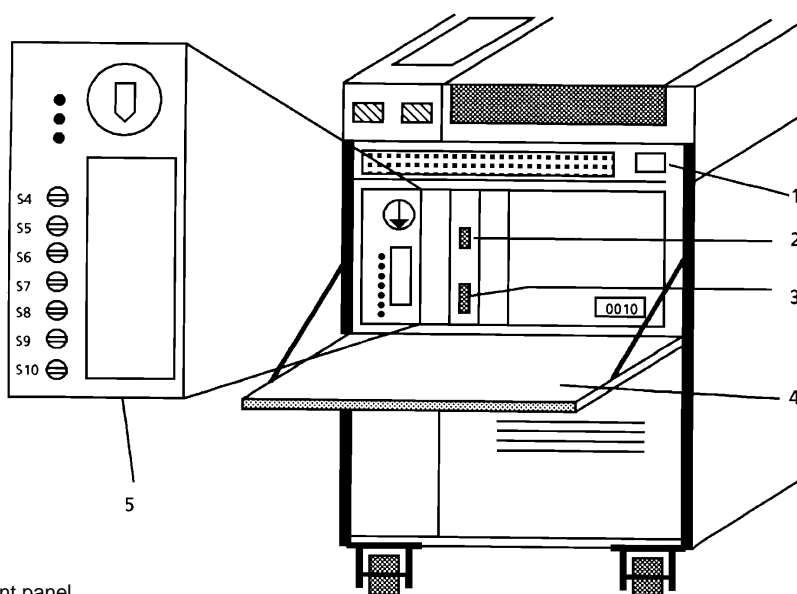
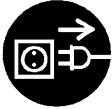

Fig. 19 Fuses on the power distribution (LV) front panel

Exchanging the fuses:

Caution

Before exchanging the fuses, switch off the unit and disconnect it from the mains.



Flip the upper front panel (19/4) down so that it is placed horizontally.

Use a screwdriver to loosen the required fuse cap by turning it to the right (Bajonett lock).

Take out the fuse cap together with the fuse.

Exchange the fuse.

Reassemble in the reverse order.

Note

The main fuses of the UL 500 are located on the LV assembly board and can only be changed by removing the board. They may only be exchanged by suitably qualified electricians!

3.4 Exchanging the Filter Mat

The filter mat (20/4) is located inside the rear panel and has to be exchanged when applicable. (It is available as an accessory Ref. No. 200 59 736.)

Use a screwdriver to turn the quick locks (20/2) by 90 °, thus loosening them.

Carefully flip the upper part of the rear panel backwards.

Pull the plug (20/6) for the ventilators located on the middle bar.

Carefully pull the rear panel (20/1) up and backwards from the fixing bolts and push slightly to the back.

Note

When pushing back the rear panel take care that the connected mains cable and any possibly connected hoses are not caught by the cut-out.

Remove both clips (20/3) from the holding rods (20/5).

Detach the filter mat (20/4) and exchange it.

After having exchanged the filter mat slightly compress the clips so as to insert them between the holding rails.

Then reassemble in the reverse order.

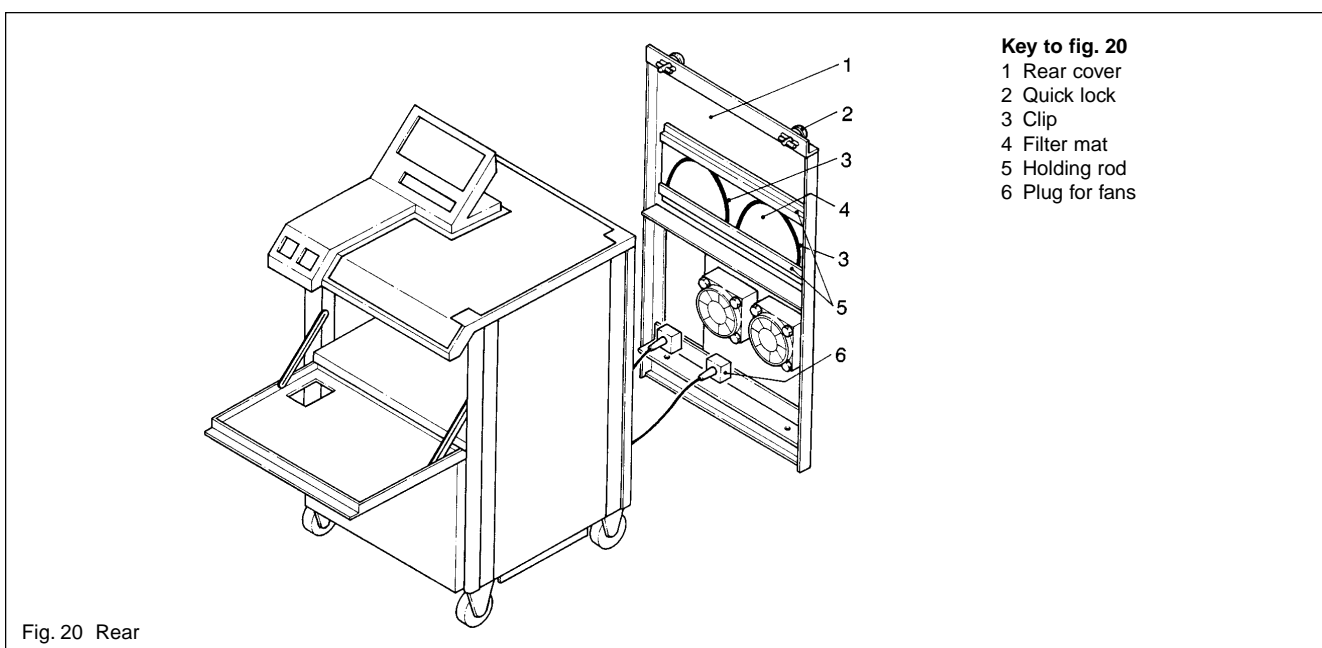

Key to fig. 20

- 1 Rear cover
- 2 Quick lock
- 3 Clip
- 4 Filter mat
- 5 Holding rod
- 6 Plug for fans

Fig. 20 Rear

3.5 Draining Condensate from the Compressor Buffer Vessel

Depending on the operating conditions condensed water may collect in the compressor buffer vessel (21/3) of the compressor assembly (21/1).

The buffer vessel has to be drained when applicable.

Note

Each time the oil of the pumps is exchanged the buffer vessel should also be checked.

Use a screwdriver to turn the quick locks (20/2) by 90 °, thus loosening them.

Carefully flip the upper part of the rear panel backwards.

To drain the buffer vessel (21/3) it has to be unscrewed from the pressure distribution block (21/2).

A 17 mm spanner is required for this purpose.

Note

A gasket is placed on the thread of the buffer vessel, which may drop off when draining the buffer vessel. A lost gasket can be replaced by a new gasket available under Ref. No. 239 73 136.

Next drain the buffer vessel with the opening pointing downwards.

Before reassembly check the seating of the gasket on the buffer vessel.

Then reassemble in the reverse order.

Key to Fig. 21

- 1 Compressor assembly
- 2 Pressure distribution block
- 3 Buffer vessel

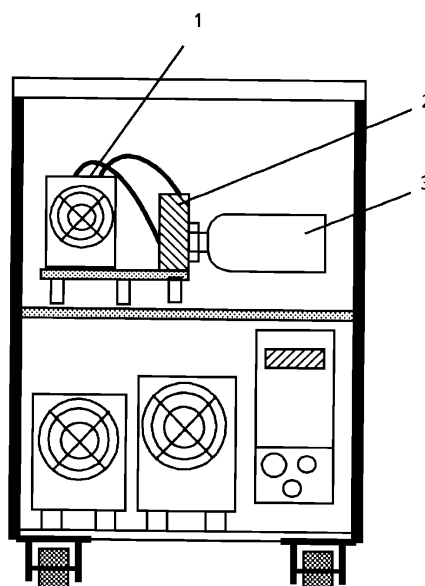

Fig. 21 Rear (compressor unit)

ANNEX 1

Parameter entry mode (PARA MODE)

For proper operation the UL 500 requires some parameters, which are partly specific to the unit and some which can be changed by switching to other operating modes. The parameters are stored in a battery backed up memory and are not lost when switching off the mains. Should none-the-less the data be lost, the entry of the parameters is automatically requested after switching on the mains.

Stored are the following:

- Nominal speed of the turbo pump
- Leak rate of the internal calibrated leak
- Set mass
- Type of the built-in auxiliary pump
- Set leak rate unit
and in case of a built-in clock
- Date
- Time.

In order to display these data and to change them, the UL 500 has to be set up in the parameter entry mode:

- The UL 500 is switched off or must be switched off from normal operation (leave switched off for several seconds).
- Operate the mains switch and **at the same time** press the „OPT“ pushbutton and keep it pressed down further. The alphanumerical display will indicate one after the other:

LEYBOLD VACUUM Remains for 1 s.
PARA INPUT ? EXEC/CLR Now the „OPT“ pushbutton may be released.

- For switching on the PARA mode this question has to be acknowledged by the „EXEC“ pushbutton. (Operating „CLR“ will lead to normal operation.)
After „EXEC“ the following is displayed:

PREPARING PARA INPUT Remains for 1 s
UL 500 VERS 1.7 Remains for 1 s.

- Now at first the same selftest of the processors is performed as for normal operation.

PERFORMING SELFTEST

- If this test is performed without errors the UL 500 is set to the PARA mode. All programmed parameters can be displayed and changed (for entering any changes numbers can be entered at the flashing positions or the parameter selections selected by the pushbuttons „ARROW RIGHT“ and „ARROW LEFT“.) Every selection has to be acknowledged by „EXEC“. Any already programmed parameters can be called up again by „CLR“.

TMP = ? 600 RPS

- The programmed nominal speed of the turbomolecular pump is indicated.
(A value between 600 and 720).
If the value is to be changed after exchanging the TMP the number given on the name plate of the pump has to be entered. This name plate is accessible behind the right hand front panel.
- Complete the entry with „EXEC“. The following is displayed:

TESTLK = ? 5.0E-07 ML/S

- Enter the correct value of the calibrated leak (e.g. 6.5E-07 ML/S). This value can be read off the calibrated leak after removing the rear cover of the work panel. Two leak rates are given on the calibrated leak, these being the calibrated leak rate and the effective corrected leak rate due to the mounting situation. The corrected value has to be entered. Permitted range $1 \cdot 10^{-7}$ to $9.9 \cdot 10^{-7}$.
- Complete the entry with „EXEC“. The following is displayed:

MASS = ? 4 u

- Enter the correct mass number (2, 3 or 4 u).
- Complete the entry with „EXEC“. The following is displayed:

PH = ? D25 B

- Select the type of built-in auxiliary pump with „ARROW RIGHT“ or „ARROW LEFT“ (D16B, D25B, D40B, D65B).
- Complete the entry with „EXEC“. The following is displayed :

LEAKRATE UNIT = ? MLS

- Select the desired leak rate unit with „ARROW RIGHT“ or „ARROW LEFT“ (**MLS** = mbar·l·s⁻¹, ACS = Atm·cc/s, PMS = Pa·m³/s).
- Complete the entry with „EXEC“. The following is displayed:

DATE = ? dd.mm.yy.

- Enter the current date (Day - Month - Year). This is only requested, provided the clock module has been built-in.
- Complete the entry with „EXEC“. The following is displayed:

TIME = ? hh:mm:ss

- Enter the current time (Hour - Minute - Second). This is only requested, provided the clock module has been built-in.
- Complete the entry with „EXEC“.

This completes the entry process and the instrument will automatically start running up the pumps, thereby returning to normal operation.

ANNEX 2

Operation of the UL 500 on mass 2 and 3 (Hydrogen)

For special applications the UL 500 may be switched from operation on mass 4 (helium) to operation on mass 2 or mass 3 (see Annex 1, PARA MODE).

Mass 2 represents the molecular hydrogen ion H_2^+ and mass 3 the H_3^+ ion, which is produced by addition of the molecular H^+ ion (from H_2O).

Depending on the number of operating hours of the unit, a relatively high hydrogen background may accumulate relative to the detection limit, which requires the adaptation of some automatic sequences especially for operation on mass 2.

The differences are given in Table 1.

Besides for measurements on hydrogen, mass 3 can be used for the detection of $3He$. The UL 500 is linear also for this mass, but the detection limit is somewhat reduced because of the existing background.

Table 1 Difference in operation on mass 2, 3 and 4

| | Mass 2 | Mass 3 | Mass 4 |
|--|---------------------|---------------------|--|
| Run up | no | no | yes, with internal leak |
| Sensitivity test | | | |
| AUTOTUNE | yes with background | yes with background | Test pos.: no Test neg.: yes with int. leak |
| ZERO | yes | yes | yes |
| Lowest display limit: | | | |
| VAC ($mbar \cdot l \cdot s^{-1}$) | $2 \cdot 10^{-6}$ | $2 \cdot 10^{-9}$ | $2 \cdot 10^{-10}$ |
| SNIFF / RATE ($mbar \cdot l \cdot s^{-1}$) | $2 \cdot 10^{-3}$ | $2 \cdot 10^{-6}$ | $2 \cdot 10^{-7}$ |
| SNIFF / CONC (ppm) | $2 \cdot 10^2$ | $2 \cdot 10^{-1}$ | $2 \cdot 10^{-2}$ |
| CAL INT possible | no | no | yes |
| CAL EXT possible | yes | yes | yes |

ANNEX 3

Equipment messages; Messages for the operator on the text display

The following messages on the alphanumeric text display inform the user about incorrect entries during certain operating modes. These are listed in the following together with further explanations where applicable.

Messages during LIMIT function

INVALID KEY

An invalid key was operated.

INVALID INTERVAL

The interval selected is too small.

INVALID ARGUMENT

A number should have been entered.

LIMIT LOW<<

Value entered for limit low was too low.

LIMIT LOW>>

Value entered for limit low was too high.

LIMIT HIGH<<

Value entered for limit high was too low.

LIMIT HIGH>>

Value entered for limit high was too high.

NO INTERVAL IN ZERO

It is not possible to enter an interval with upper and lower limit when the Zero function is active.

SET FIRST LIMIT LOW

The upper limit can not be entered before entering the lower limit.

Messages during OPT function

CLEAR CAL EMV

Termination of the CAL EMV process.

PERFORMING CAL EMV

CAL EMV process is running.

PERFORMING AUTOTUNE

The sensitivity alignment for AUTOTUNE is running.

PERFORMING AUTOZERO

The Zero alignment for AUTOZERO is running.

26:NO CALEMV IN STBY

OPT 26: CALEMV is not possible during STANDBY (switch to DETECT).

27:NO EXT-V.24

OPT 27 cannot be carried out as the V.24 interface option has not been built-in.

24:NO TUNE IN DETECT

OPT 24: TUNE is not possible during DETECT (switch to STANDBY).

10:NO TRIGGER

OPT 10 cannot be carried out as the trigger option has not been built-in.

25:NO ZERO IN DETECT

OPT 25: ZERO is not possible during DETECT (switch to STANDBY).

CLEAR AUTOTUNE

Termination of the AUTOTUNE process.

15:OPT UNAVAILABLE

OPT function is not used.

CLEAR AUTOZERO

Termination of the AUTOZERO process.

Messages when pressing other keys

CLEAR CAL EXTERN

Termination of the external calibration process.

CLEAR CAL INTERN

Termination of the internal calibration process.

CAL EXTERN

Running of the external calibration process.

CAL INTERN

Running of the internal calibration process.

GAS BALLAST IS ACTIV

Option: Elektromagnetic gas ballast is open.

DETECTING <INSP>

INSPECT measurement mode

INVALID ARGUMENT

Entry of a wrong key

INTERPRETER ERROR

Internal software or hardware error.

DETECTING <MEAS>

MEASURE measurement mode

NO CAL IN <INSPECT>

Calibration during the INSPECT mode is not possible.

NO CAL IN <STANDBY>

In the SNIFF mode only external calibration is possible. Switch to MEASURE.

WARNING:MAX IS ACTIV

For external calibration the MAX function should be switched off.

NO CONC IN <VACUUM>

In the VACUUM mode no concentrations can be displayed.

NO CHANGE IN DETECT

Switching to VAC / SNIFF is only possible during STANDBY.

NO INPUT DURING CAL

No entries can be made during a calibration.

NO MAX IN <STBY>

MAX function is only possible during DETECT.

NO MAX IN <INSP>

MAX function is only possible in the MEASURE mode.

NO PREC IN <INSPECT>

PREC is only possible MEASURE mode.

NO ZERO IN <STBY>

The ZERO function is only possible during DETECT.

NO ZERO IN INTERVAL

The Zero function cannot be selected when displaying intervals.

NO INPUT IN REMOTE

No entries can be made via keys when the V.24 interface is active.

RESET MAX

Resetting of the MAX function.

PLEASE SEE OP-MANUAL

Refer to Operating Instructions.

STANDBY FOR <INSP>

STANDBY condition in the INSPECT mode.

STANDBY FOR <MEAS>

STANDBY condition in the MEASURE mode.

TESTLEAK<<

Helium signal of the calibrated leak is too small.

Messages sent by the control processor

AUTOTUNE FINISHED

OPT 24 finished.

AUTOZERO FINISHED

OPT 25 finished.

AUTOTUNE MASS x

AUTOTUNE for mass x running: x = 2, 3, 4

BACKGROUND TOO HIGH

Internal background is too high.

CAL: TUNING MASS x

During calibration: x = 2, 3, 4

CAL: PERFORMING ZERO

Performing Zero alignm. during calibration.

CAL: CALIBRATION

Calibration process running.

CALIBRATION FINISHED

Calibration process finished.

CATHODE 2

Switching to cathode 2 after detecting a faulty cathode 1.

CLOSE TESTLEAK! EXEC

For external calibration: Close calibrated leak.

EMISSION OFF

Emission switched off because of a fault.

NOT AVAILABLE

This function has not been implemented.

OPEN GAS BALLAST

The internal background is too high. Open gas ballast to reduce it.

OPEN TESTLEAK! EXEC

For external calibration:

Open calibrated leak.

OPEN VAR LEAK E-5 MS

During EMV resistance alignment:

Open variable leak.

PERFORMING AUTOZERO

Zero alignment performed during run up.

PLEASE WAIT

Wait until the internal process has been completed.

RUNNING UP

The turbomolecular pump is running up.

SELFTEST WITH ERRORS

Fault during initialization + hardware test.

SENSITIVITY CHECK

Sensitivity check during run up.

SIGNAL IN RANGE

During EMV resistance alignment:

The set leak rate is correct.

SIGNAL STABLE ? EXEC

During external calibration: The operator has to decide whether or not the value is stable after having made changes to the calibrated leak.

SIGNAL TOO HIGH

During EMV resistance alignment:

The leak rate set on the variable leak has been set too high.

SIGNAL TOO LOW

During EMV resistance alignment:

The leak rate set on the variable leak has been set too high.

SNIFF AIR! EXEC

During external calibration:

Place the sniffer tip in air.

SNIFF CONC! EXEC

During external calibration:

Place the sniffer tip in the concentration.

SNIFF TESTLEAK! EXEC

During external calibration:

Place the sniffer tip in the calibrated leak.

STOP: PUMP OVERLOAD

The leak detector has been in the MASSIVE range for over 10 min, and has then switched to STANDBY.

STOP: TM DEFECT

TM P1 or P 2 is defective.

TOTAL FAIL

The unit was switched off because of a failure.

TUNIG MASS x

During TUNE OPT 24 while running. x = 2, 3, 4



ANNEX 4; Error messages

The UL 500 is provided with comprehensive selftest routines. If a fault condition is detected by the control processor a corresponding error message is displayed as far as this is still possible.

The error message is displayed as clear text on the alphanumerical display (1/2) and as code on the seven segment display on the front panel of the control processor assembly (19/3).

Listed in the following are all possible error messages together with a brief explanation as to the cause of the fault. More details are given in the Service manual SA 10.204.

Important When reading „B“ and „6“ on the seven segment display reading errors can easily be made. The letter „B“ is displayed as lower case „b“ , the number 6 is displayed with an additional cross bar.

Note :  =B  =6

The seven segment display is not reset automatically but has to be reset via the pushbutton on the front panel of the STE control assembly (8/2).

| Alphanum. display | Seven segment- display |
|--|---------------------------|
| ER: TEMPERATURE>55 °C Temperature at the cal. leak is higher 55 °C. | 01H: |
| ER: TEMPERATURE<10 °C Temperature at the calibrated leak is lower than permissible. | 02H: |
| ER: RUNNING UP > 6 min Run-up time after switching on the backing pump is too long. | 03H: |
| ER:P1-U << Bridge voltage of the P1 gauge head is too low. | 04H: |
| ER:P1-U>> Bridge voltage of the P1 gauge head is too high. | 05H: |
| ER:P2-U << Bridge voltage of the P2 gauge head is too low. | 06H: |
| ER:P2-U>> Bridge voltage of the P2 gauge head is too high. | 07H: |
| ER: I-120V I>> Supply voltage VN4 is too high. | 08H: |
| ER: I-120V I<< Supply voltage VN4 is too low. | 09H: |

| | | | |
|--|-------------|---|-------------|
| ER:MSP-ANOD-CAT-U>> Difference between anode potential and cathode potential is too high. | 0AH: | ER:PEAK NOT IN RANGE In TUNE mode no maximum is found within the normal range. Maximum at the range limit. | 1CH: |
| ER:MSP-ANOD-CAT-U<< Difference between anode potential and cathode potential is too low. | 0BH: | ER:SIGNAL NOT STABLE In TUNE mode no stable signal is measured. | 1DH: |
| ER:MSP-SUP-POT>> Suppressor potential of the mass spectrometer is too high. | 0CH: | ER:TUNE DIFFERENCE In the TUNE mode the minimum/maximum voltage difference in the normal range is too small for reliable peak detection. | 1EH: |
| ER:MSP-SUP-POT<< Suppressor potential of the mass spectrometer is too low. | 0DH: | ER:CAL-DIFFERENCE<< In the CAL mode the voltage difference maximum/minimum is too small. | 1FH: |
| ER:MSP-ANOD-POT>> Anode potential of the mass spectrometer is too high. | 0EH: | ER:MSP-SUP-NOM>> Error message from MV, if the set value is too high in the suppressor control loop. | 20H: |
| ER:MSP-ANOD-POT<< Anode potential of the mass spectrometer is too low. | 0FH: | ER:MSP-ANOD-NOM>> Error message from MV, if the set value is too high in the anode potential control loop. | 21H: |
| ER: +/-15V>> Supply voltage VP/VN is too high. | 10H: | ER:I-CAT-HEATER>> Error message from MV, if the cathode current is too high. | 22H: |
| ER: +/-15V<< Supply voltage VP/VN is too low. | 11H: | ER:I-CAT-HEATER<< Error message from MV, if the cathode current is too low. | 23H: |
| ER: +24V>> Supply voltage VP/2 is too high. | 12H: | ER:FUSE-ANO-HEAT DEF Fuse of the anode heating circuit has blown on MV. | 24H: |
| ER: +24V<< Supply voltage VP/2 is too low. | 13H: | ER:MSV-24V<< Error message from MV when the supply voltage is too low. | 25H: |
| ER:TMP +15V>> Voltage of TMP-supply is too high. | 14H: | ER:NO EMISSION Error message from MV when the emission current fails . | 28H: |
| ER:TMP +15V<< Voltage of TMP-supply is too low. | 15H: | ER:COMPRESSOR-I>> Current of compressor motor is too high. | 2CH: |
| ER:BATTERY-U<< Voltage of the backup battery is too low (applicable only without clock assy.). | 16H: | ER:COMPRESSOR-I << Current of the compressor motor is too low (is only measured if the signalling pressure switch indicates that the pressure in the vessel has dropped below 1.5 bar). | 2DH: |
| ER:D/A U-REF>> Reference voltage on control assy. STE is too high. | 17H: | ER:ROUGHING-P,-I>> Current of auxiliary pump motor too high. | 2EH: |
| ER:D/A U-REF<< Reference voltage on control assy. STE is too low. | 18H: | ER:ROUGHING-P,-I<< Current of the auxiliary pump motor too low and the auxiliary pump relay is active . | 2FH: |
| ER:A/D-CONVERTER DEF A/D converter on control assy. STE is faulty. | 19H: | | |
| ER:STE-MUART DEF MUART-IC on the CPU of control assy. STE is faulty. | 1AH: | | |
| ER:EMV-OFFSET>> Electrical offset of the high impedance input amplifier is too high. | 1BH: | | |

| | | | |
|--|-------------|--|-------------|
| ER:BACKING-P-I>> Current of backing pump motor too high. | 30H: | ER:ROUGHING-P, OVERL Overload of auxiliary pump. (contact not energized) | 49H: |
| ER:BACKING-P-I<< Current of backing pump motor too low. | 31H: | ER:TMP-VENT V. DEF Venting valve VF2 for turbomolecular pump and rough vacuum does not switch. | 50H: |
| ER:TMP U-LINK>> Error message of the TPV if the intermediate circuit dc is too high. | 3CH: | ER:TESTLEAK V. DEF Calibrated leak valve VT does not switch. | 51H: |
| ER:TMP U-LINK<< Error message from the TPV if the intermediate circuit dc is too low. | 3DH: | ER:COUPLING V. DEF Coupling valve VK does not switch. | 52H: |
| ER:TMP I-LINK>> Error message from the TPV if the intermediate circuit dc is too high. | 3EH: | ER:BYPASS V. DEF Bypass valve VB does not switch. | 53H: |
| ER:TMP I-LINK<< Error message from the TPV if the intermediate circuit dc is too low. | 3FH: | ER:INLET V. DEF Inlet valve VE does not switch. | 54H: |
| ER:TMP-FREQ>> Error message from the TPV if the nominal speed of the rotor of the turbomolecular pump is too high. | 40H: | ER:ROUGHING V. DEF Auxiliary pump valve VH does not switch. | 55H: |
| ER:TMP-FREQ<< Error message from the TPV if the nominal speed of the rotor of the turbomolecular pump is too low. | 41H: | ER:VENTING V. DEF Venting valve VF1 does not switch. | 56H: |
| ER:TMP OVERLOAD-T Error message from TPV in case of over-temperature of the motor (T > 65 °C). | 42H: | ER:GASBALLAST V. DEF Gas ballast valves VG1 / VG2 do not switch (only with built-in option). | 57H: |
| ER:TMP OVERLOAD-I Error message from TPV in case of over-current of the TMP motor (I > 12 A). | 43H: | ER:COMPRESSOR-P<< Pressure in the compressor vessel is too low | 5AH: |
| ER:TMP OVERLOAD-U Error message from TPV in case of overvoltage of the TMP motor (U > 80 V). | 44H: | ER1:STATUS-CRC-ERROR Error during check of status byte. | 60H: |
| ER:TMP OVERLOAD-FREQ Error message of TPV if the actual speed of the turbopump exceeds the set value. | 45H: | ER1:INVALID STATE Invalid equipment status. | 61H: |
| ER:TMP-CONT NO COMMU Connection between TPV assy. and STE assy. is not working properly. | 46H: | ER1:INVALID STRING Invalid data or commands on the internal V.24 interface. | 62H: |
| ER:PHASE MISSING In case of 3-phase mains supply one phase is missing. | 47H: | ER1:VERSION CONFLICT Software conflict between the two processors. | 91H: |
| ER:PHASE SEQUENCE In case of 3-phase mains supply two of the phases are interchanged. | 48H: | ER1:CHECK ERROR E.O. Error within the internal V.24 connection. | 92H: |
| | | ER1:CHECK ERROR ID Error within the internal V.24 connection. | 93H: |
| | | ER1:TIME OUT IDENT Error within the internal V.24 connection | 95H: |
| | | ER1:TIME OUT INIT Error within the internal V.24 connection. | 96H: |
| | | ER1:DSR INACTIV INIT Error within the internal V.24 connection. | 97H: |
| | | ER1:DSR INACTIV Error within the internal V.24 connection. | 98H: |

ER1:TIME OUT ECHO O.
Error within the internal V.24 connection.

9AH:

ER1:ACIA-OVERRUN
Error within the internal V.24 connection.

9BH:

ER1:DSR AKTIV
Error within the internal V.24 connection.

9CH:

ER1:PARITY-ERROR
Error within the internal V.24 connection.

9EH:

ER1:DATA LOST
Error within the internal V.24 connection.

9FH:



Declaration of Contamination of Vacuum Equipment and Components

The repair and/or service of vacuum equipment and components will only be carried out if a correctly completed declaration has been submitted. Non-completion will result in delay. The manufacturer could refuse to accept any equipment without a declaration.

This declaration can only be completed and signed by authorized and qualified staff.

Copies: Page 1 (white) to manufacturer or representative - Page 2 (yellow) attach to consignment packaging security - Page 3 (blue) copy for file of sender

1. Description of Vacuum Equipment and Components

- Equipment type/model: _____
- Code No.: _____
- Serial No.: _____
- Invoice No.: _____
- Delivery date: _____

2. Reason for Return

3. Condition of the Vacuum Equipment and Components

- Has the equipment been used?
yes no
- What type of pump oil/liquid was used? _____
- Is the equipment free from potentially harmful substances?
yes (go to Section 5)
no (go to Section 4)

4. Process related Contamination of Vacuum Equipment and Components:

- toxic yes no
- corrosive yes no
- explosive*) yes no
- biological hazard*) yes no
- radioactive*) yes no
- other harmful substances yes no

*) Vacuum equipment and components which have been contaminated by biological explosive or radioactive substances, will not accepted without written evidence of decontamination!

Please list all substances, gases and by-products which may have come into contact with the equipment:

| Trade name Product name Manufacturer | Chemical name (or Symbol) | Dangerous material class | Measures if spillage | First aid in case of human contact |
|--|------------------------------|-----------------------------|-------------------------|---------------------------------------|
| 1. | | | | |
| 2. | | | | |
| 3. | | | | |
| 4. | | | | |
| 5. | | | | |

5. Legally Binding Declaration

I hereby declare that the information supplied on this form is complete and accurate. The despatch of the contaminated vacuum equipment and components will be in accordance with the appropriate regulations covering Packaging, Transportation and Labelling of Dangerous Substances.

Name of organisation or company: _____

Address: _____ Post code: _____

Tel.: _____

Fax: _____ Telex: _____

Name: _____

Job title: _____

Date: _____ Company stamp: _____

Legally binding signature: _____

This page has been left blank for your comments.

