

Vacuum Solutions

Application Support

Service



LEYBOLD VACUUM

GA 05.223/4.02



# TURBO.DRIVE S

Frequency Converter for  
Turbomolecular Pumps

Part No. 800070Vxxxx

Operating Instructions

---

## Contents

	Page
1 Description .....	3
1.1 Standard equipment .....	3
1.2 Ordering data .....	6
1.3 Technical data .....	12
2 Connections .....	14
2.1 Operating environment .....	14
2.2 Mount the frequency converter .....	14
2.3 Connect the pump .....	14
2.4 Connect the power supply .....	15
2.5 Relay status .....	18
3 Operation .....	19
3.1 Switching on .....	19
3.2 Shutting down .....	19
3.3 Maintenance .....	20
4 Interface description .....	20
4.1 RS 232 interface .....	22
4.2 RS 485 interface .....	23
4.3 Profibus DP .....	23
4.4 Parameter list .....	25
4.5 Specific parameter data for the pumps .....	29
4.6 Error codes for the parameter P171 .....	30
5 Troubleshooting .....	31
EC Declarations .....	36

## Figures

The references to the diagrams, e.g. (2/10), consist of the figure number and the item number, in that order.

## Warning

Identifies working and operating procedures which must be strictly observed to prevent hazards to persons.

## Caution

Indicates working and operating procedures which must be strictly observed to prevent damage to or destruction of the appliance.

We reserve the right to alter the design or any data given in these Operating Instructions.  
The illustrations are approximate.

---

# 1 Description

The TURBO.DRIVE S supplies power to the TW series turbo-molecular pumps and is used to control their operation.

The TURBO.DRIVE S is suited for operation of the following pumps:

- TURBOVAC TW 70 H
- TURBOVAC TW 220/150 S, TW 220/150/15 S
- TURBOVAC TW 250 S
- TURBOVAC TW 300, TW 300 H

Other pumps may only be operated after approval from Leybold or if the operation of such pumps is expressly permitted in the Operating Instructions for the specific pump.

The TURBO.DRIVE S is either integrated in the pump or it is separate and linked to the pump by means of a connecting cable.

The TURBO.DRIVE S requires a supply voltage of 24 V DC. It is equipped with interfaces for programmable controls (REMOTE) and an optional interface for serial communication.

The TURBO.DRIVE S complies with SELV requirements (Safety Extra Low Voltage).

The TURBO.DRIVE S must only be opened by certified Leybold Service Centres. Opening by unauthorised personnel voids warranty.

## Warning



Inside the unit there is the risk of suffering burns from hot components.

### 1.1 Standard equipment

Included with the delivery are the DC connector Hirose HS16P-3, four moving nuts M4 for affixing the frequency converter and the Operating Instructions.

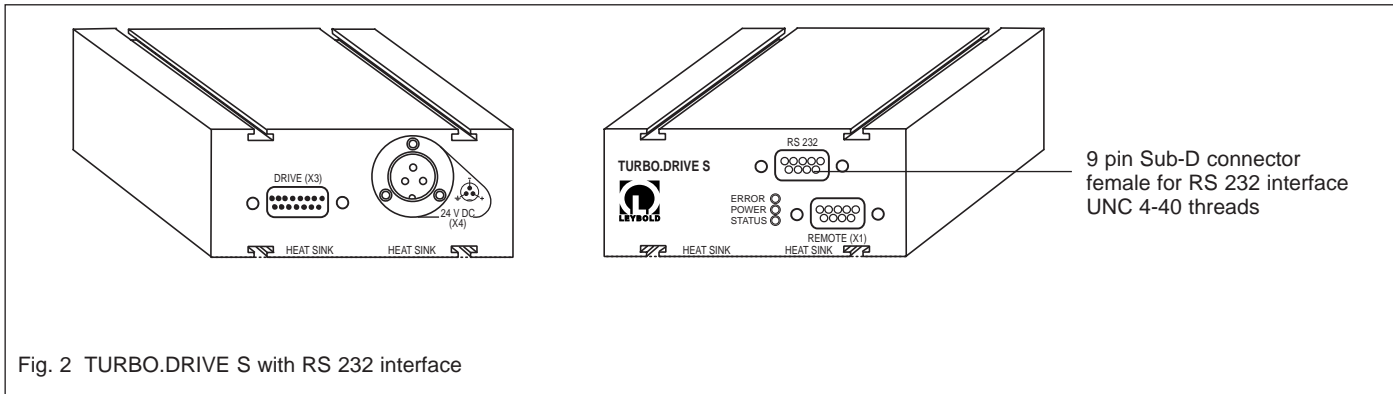
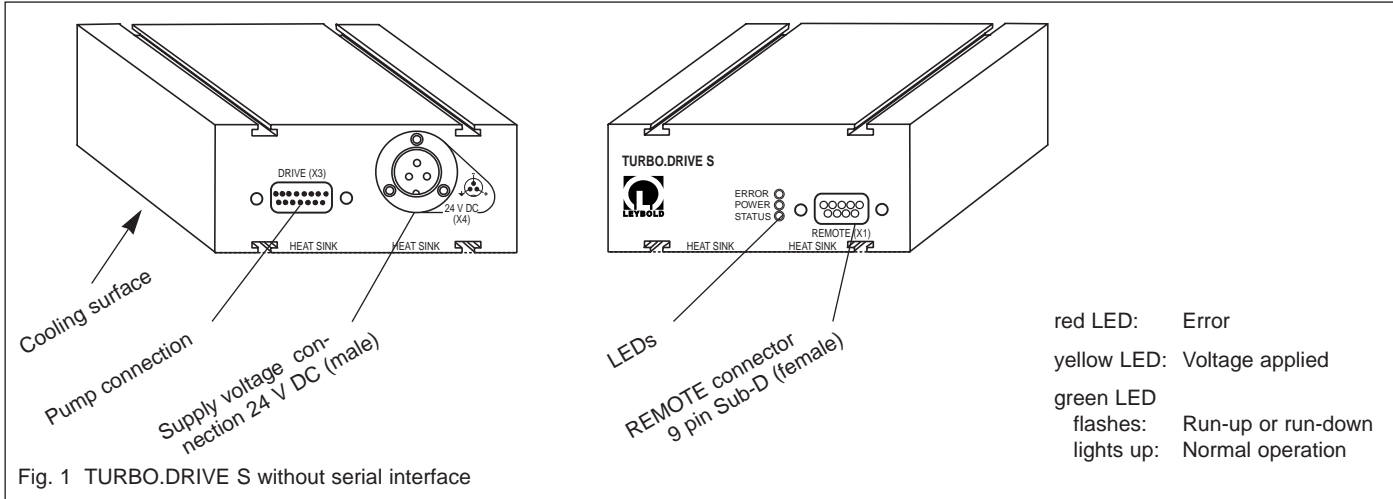

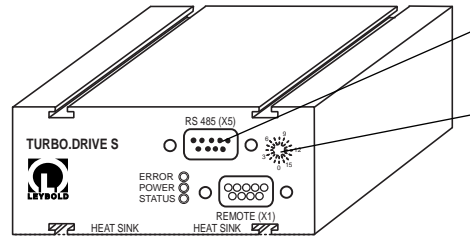
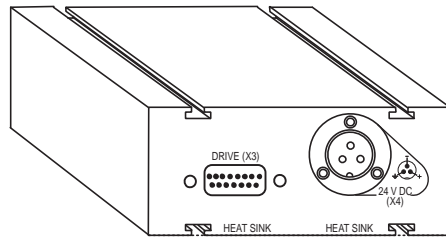

9 pin Sub-D connector male for RS 485 interface  
UNC 4-40 threads

Switch for bus address, 0-15; for RS 485 interface

Fig. 3 TURBO.DRIVE S with RS 485 interface

2x switch for bus address, 00-FF

9 pin Sub-D connector female for Profibus interface  
UNC 4-40 threads

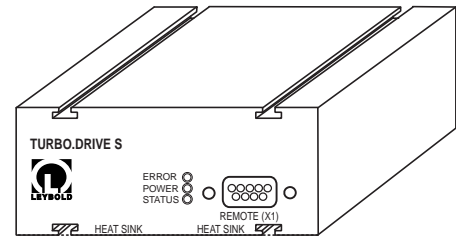
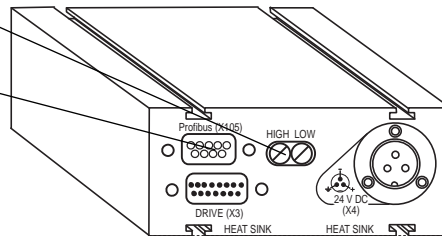
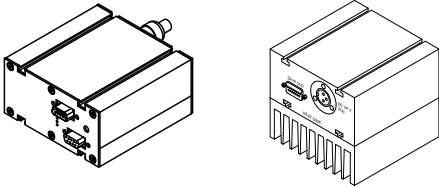
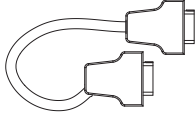
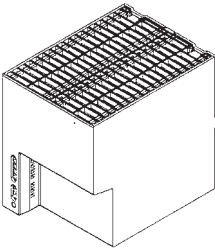



Fig. 4 TURBO.DRIVE S with Profibus interface

## 1.2 Ordering data

<p><b>Frequency converter TURBO.DRIVE S</b></p> <p>Basic unit</p> <p>with RS 232 interface</p> <p>with RS 232 interface and mounted heat sink</p> <p>with RS 485 interface</p> <p>with RS 485 interface and mounted heat sink</p> <p>with Profibus interface</p>	<p>800070V0001</p> <p>800070V0002</p> <p>800070V0005</p> <p>800070V0003</p> <p>800070V0006</p> <p>800070V0004</p>	
<p><b>Connecting cable pump - frequency converter</b></p> <p>1.0 m long</p> <p>2.5 m long</p> <p>3.0 m long</p> <p>5.0 m long</p>	<p>152 47</p> <p>864 49</p> <p>864 40</p> <p>864 50</p>	

**OEM power supply (with screw terminals)**

<p><b>SITOP 24 V / 10 A</b></p> <ul style="list-style-type: none"> <li>• supplies the TURBO.DRIVE S with 24 V DC</li> <li>• other power supplies on request</li> </ul>	<p>152 50</p>	
<p><b>24 V DC cable (TURBO.DRIVE S – OEM power supply)</b></p> <p>3 m 5 m 10 m 20 m</p>	<p>200 12 732 200 12 733 200 12 734 200 12 735</p>	
<p><b>Mains cable for power supply, 2 m long</b></p> <p>with EURO plug with US plug 5-15P</p>	<p>800102V0001 800102V1001</p>	

---

**Power supply unit - plug and play**

<b>TURBO.POWER 300</b> <ul style="list-style-type: none"><li>• supplies the TURBO.DRIVE S with 24 V DC</li><li>• plug &amp; play cables</li><li>• desktop unit or rack mountable</li></ul>	800100V0002	
<b>24V DC Power cable (TURBO.DRIVE S – TURBO.POWER 300)</b> 1 m 3 m 5 m 10 m 20 m	800094V0100 800094V0300 800094V0500 800094V1000 800094V2000	
<b>Mains cable for TURBO.POWER 300, 3 m long</b> with EURO plug with US plug 6-15P	800102V0002 800102V1002	

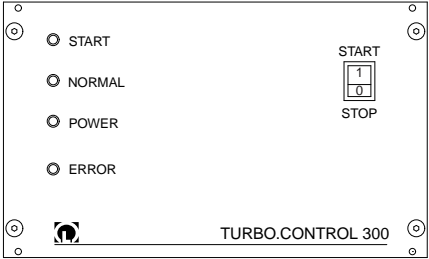
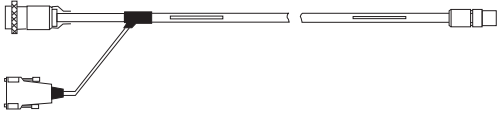

## Power supply and control unit

<p><b>TURBO.CONTROL 300</b></p> <ul style="list-style-type: none"> <li>• supplies the TURBO.DRIVE S with 24 V DC</li> <li>• plug &amp; play cables</li> <li>• desktop unit or rack mountable</li> <li>• with power switch</li> <li>• with start/stop switch for the turbomolecular pump</li> <li>• remote control</li> <li>• status LEDs and status relays</li> </ul>	<p>800100V0001</p>	
<p><b>24V DC Control cable (TURBO.DRIVE S – TURBO.CONTROL 300)</b></p> <p>1 m 3 m 5 m 10 m 20 m</p>	<p>800091V0100 800091V0300 800091V0500 800091V1000 800091V2000</p>	
<p><b>Mains cable for TURBO.CONTROL 300,</b> 3 m long</p> <p>with EURO plug with US plug 6-15P</p>	<p>800102V0002 800102V1002</p>	

## Mechanical accessories

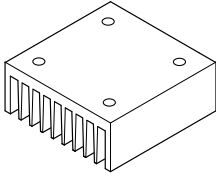
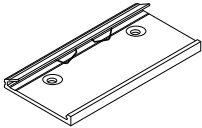
Plug for connector REMOTE with integrated <b>ON/OFF switch</b> for the pump (Sub-D plug, 9 way)	152 48	
<b>Heat sink</b> for frequency converter	800110V0001	
Top hat rail adaptor (mounting aid for TURBO.DRIVE S and TURBO.POWER 300)	800110V0003	

## Accessories for serial interfaces

<p><b>Display Palm M100/105*</b> (display unit for parameters, requires the software "Turbo.Drive Panel")</p>	<p>800110V0105</p>	
<p>Required "<b>Turbo.Drive Panel</b>" software for the display Palm M100/105, 3.5" floppy</p>	<p>800110V0104</p>	
<p>PC software "<b>Turbo.Drive Server</b>" for Windows 95 and higher, CD-ROM*</p> <ul style="list-style-type: none"> <li>• Display, change, save and compare parameter lists</li> <li>• Integration of customer's software</li> <li>• Record parameter data</li> </ul>	<p>800110V0102</p>	
<p>Adaptor RS232/RS485 for 220 V/Euro plug</p>	<p>800110V0101</p>	
<p>GSD file for Profibus DP</p>	<p>upon request</p>	
<p>* Can be used in connection with the following interfaces:</p> <ul style="list-style-type: none"> <li>- For frequency converters with RS232 interface.</li> <li>- For frequency converters with RS485 interface, a RS232/RS485 adaptor is required.</li> </ul>		

### 1.3 Technical data

Supply voltage	24 V DC $\pm$ 5%
Residual ripple	< 2%
When operating a TW 300, TW 300 H, TW 220/150(/15) S	
Max. power consumption	190 W
Max. peak current, input side	8 A DC
Required power output from the power supply	$\geq$ 200 W
When operating a TW 70 H, TW 250 S	
Max. power consumption	140 W
Max. peak current, input side	6 A DC
Required power output from the power supply	$\geq$ 150 W
Max. length of the DC cable (shielded)	
at 3 x 1.5 mm <sup>2</sup>	5 m
at 3 x 2.5 mm <sup>2</sup>	20 m
Load capability, relay output	42 V, 0.5 A
Ambient temperature	
during operation	10 - 45 °C
storage	- 15 - + 70 °C
Temp. of the cooling surface	
Only Part No. 800070V0004	10 - 55 °C
	10 - 50 °C
Power loss	$\leq$ 20 W
Relative air humidity acc. to DIN EN 60721	Class F
Type of protection	IP 20
Weight, approx.	0.7 kg

<b>Power supply</b>	<b>SITOP 24 V / 10 A</b>
AC input voltage	120/230 V, 50/60 Hz
Tolerance	93 - 132 V 187 - 264 V
Recommended circuit breaker (characteristic C)	16 A
Power consumption	270 W
DC output voltage	24 V $\pm$ 1%
DC output current	0 - 10 A
Weight, approx.	1 kg
Mounting	DIN rail
Screw-type terminals	0.5 - 2.5 mm <sup>2</sup> 22 - 12 AWG
Ambient temperature	
during operation	0 - 60 °C
storage	-25 - + 85 °C
Cooling	air convection
Type of protection	IP 20
Safety to EN60950	SELV
RI suppression to EN 55022	limit curve B
Noise immunity to EN 50082-2	incl. Table A4
UL508 FILE	E143289

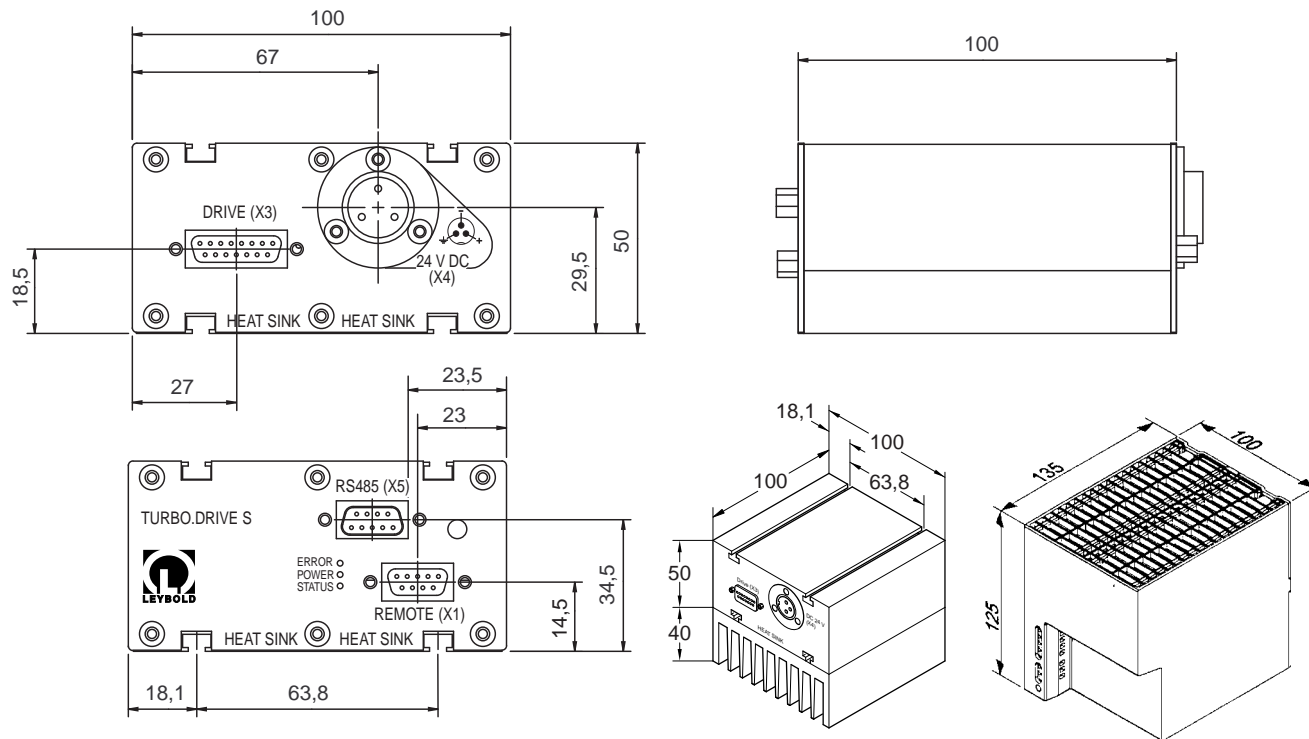

Fig. 5 Dimensional drawing for the TURBO.DRIVE S with RS 485 interface and the OEM power supply unit, dimensions in mm

## 2 Connections

### 2.1 Operating environment

Places of installation up to 1000 m above sea level (3300 ft) are possible without restrictions. At altitudes over 1000 m heat dissipation by the ambient air is impaired. Please consult us.

If the TURBO.DRIVE S has been integrated in the pump, it is cooled by the pump.

As to the cooling requirements for the separately fitted TURBO.DRIVE S see Fig. 6. The bottom side of the frequency converter must not be allowed to attain temperatures in excess of 55 °C, in the case of frequency converters equipped with a Profibus interface the temperature at the bottom must not exceed 50 °C.

Max. magnetic induction levels are 15 mT, max. radioactive radiation spec. is  $10^5$  rad ( $10^3$  Gy).

The frequency converter must not be operated in explosive gas atmospheres.

The frequency converter and the connecting lines must be protected against exposure to sprayed and condensing water.

### 2.2 Mount the frequency converter

The frequency converter may be affixed with the aid of the enclosed M4 sliding nuts. The bottom side of the frequency converter must be cooled sufficiently.

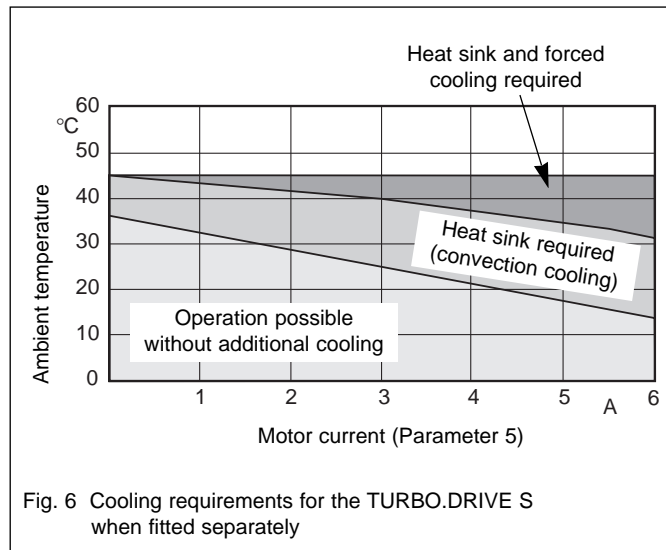

Fig. 6 Cooling requirements for the TURBO.DRIVE S when fitted separately

If the frequency converter is mounted without the optional heat sink ensure sufficient cooling by other means.

For special requirements please contact Leybold.

### 2.3 Connect the pump

In the case of a separately fitted TURBO.DRIVE S connect the pump using the connecting cable.

## Caution

The pump may be operated only with a suitable frequency converter and suitable connector cables.

Route all cables so as to protect them from damage.

**Disconnect and connect the cable connections only while the pump is turning no longer (green status LED off) and with the mains power switched off (yellow power LED off). Otherwise there is the risk of damaging the TURBO.DRIVE S.**

## 2.4 Connect the power supply

### Warning



The frequency converter must only be connected to power supplies which meet the requirements for functional extra low voltage with positive isolation in accordance with IEC 364 (VDE 0100, Part 410, or local regulations) (SELV).

The power supply must meet the requirements given in Section 1.3. Peak currents in the kHz range may be present on the DC side. The power supply should have a current limiter of be of the current regulated type.

Connect the frequency converter to the 24 V DC power supply via the 24 V DC cable.

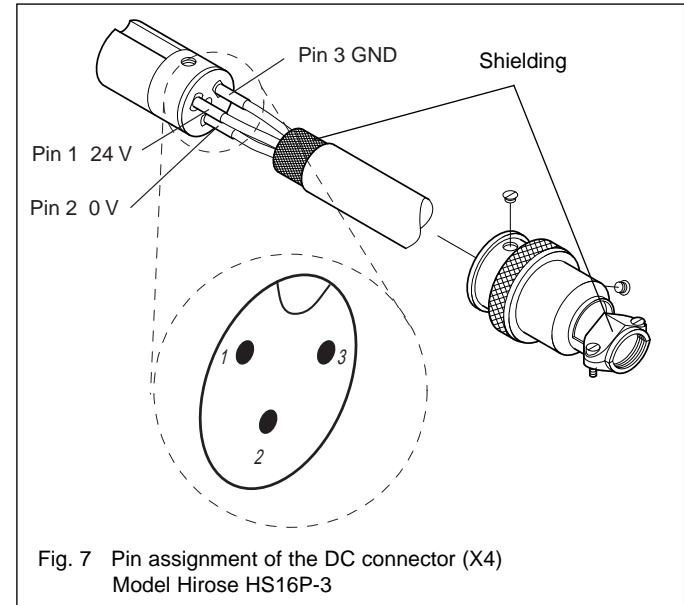

Fig. 7 Pin assignment of the DC connector (X4)  
Model Hirose HS16P-3

### Caution

Ensure correct polarity.

Pin 1 + 24 VDC

Pin 2 0 V

Pin 3 GND

A wrong polarity may cause the internal SMD fuse to blow. The fuse can only be changed by the Leybold Service.

Connect the power supply to the mains; see Fig. 8.

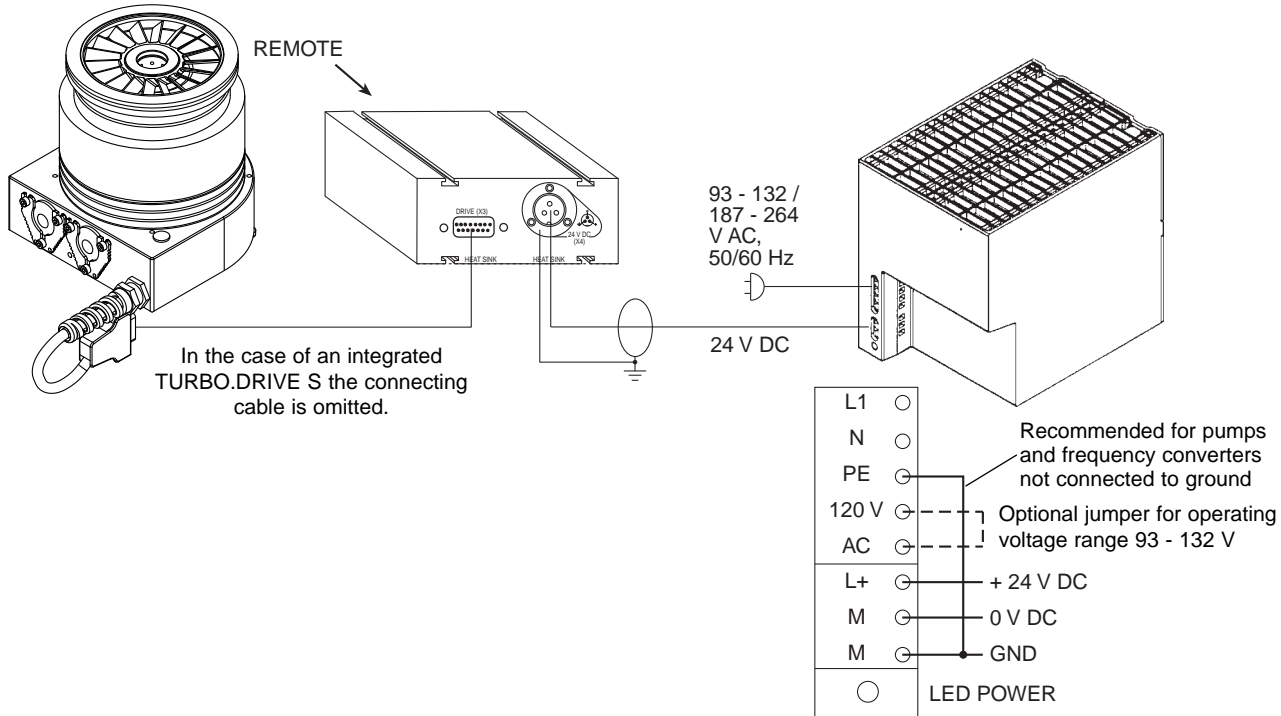

Note the Operating Instructions for the power supply.

Fig. 8 Connecting the pump and the power supply



### Pin assignment of the connector

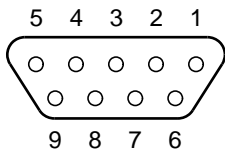

### Relay operation

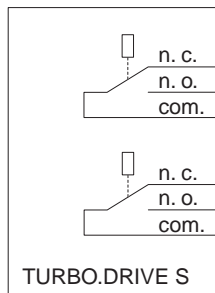

#### Relay - Normal operation

- While deceleration, acceleration, Stop: 4 connected to 5 (as shown; passive)
- During normal operation ( $f > 0,9 \cdot f_{nom.}$ ): 4 connected to 3 (active)

#### Relay - Error

- No error: 1 connected to 2 (as shown; passive)
- Error is present: 1 connected to 9 (active)

### Pin assignment for the Start/Stop input

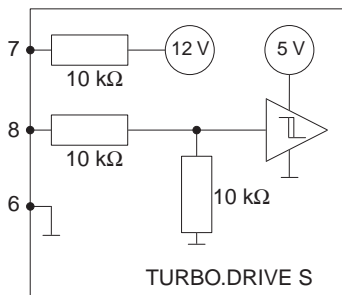

Switching threshold for the Start/Stop control input:  
 Low level:  $< 3\text{ V}$   
 High level:  $> 7\text{ V}$

### Start/Stop operation

#### Example 1: Operation via a PLC

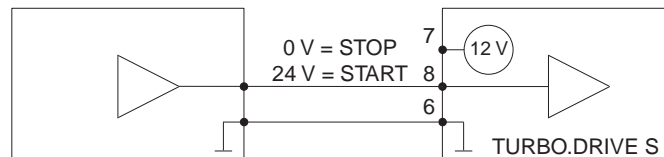

#### Example 2: Operation via contacts

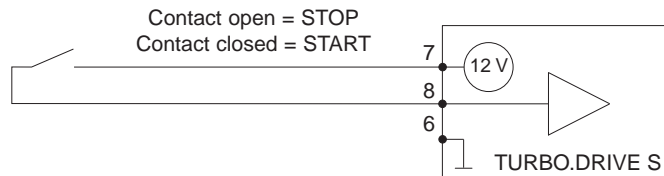

Fig. 9 Pin assignment of the REMOTE (X1) connector

## 2.5 Relay status

Input data / status				Output data					Operating mode
Start/ stop signal	Pump rotating	Normal frequency ≥ 90% of setpoint frequency	Error is present	Motor drive	Relay NORMAL OPERATION (see Fig. 9)	Relay ERROR (see Fig. 9)	LED STATUS (green)	LED ERROR (red)	
Stop	no	no	no	off	passive	passive	off	off	Pump not operating
Stop	yes	no	no	off	passive	passive	flashes	off	Pump is decelerating
Stop	yes	yes	no	off	passive	passive	flashes	off	Just after stop; pump was in the normal operating mode before that
Start	no	no	no	on	passive	passive	off	off	Just after start
Start	yes	no	no	on	passive	passive	flashes	off	Pump is accelerating
Start	yes	yes	no	on	active	passive	green	off	Pump is in the normal operating mode
Stop	no	no	yes	off	passive	active	off	red	Error is present; pump is at standstill
Stop	yes	no	yes	off	passive	active	flashes	red	Error is present; pump is decelerating
Stop	yes	yes	yes	off	passive	active	flashes	red	Error has just occurred
Start	no	no	yes	off	passive	active	off	red	Error is present; pump is at standstill
Start	yes	no	yes	off	passive	active	flashes	red	Error is present; pump is decelerating
Start	yes	yes	yes	off	passive	active	flashes	red	Error has just occurred

Other modes are not possible; they indicate a failure affecting the TURBO.DRIVE S.

---

## 3 Operation

### Warning



The turbomolecular pump and the frequency converter must only be operated in the proper condition and under the conditions described in the Operating Instructions.

### 3.1 Switching on

Switch on the 24 V DC power supply. The yellow LED at the frequency converter lights up.

Switch on the turbomolecular pump at the frequency converter

- via pins 7 and 8 of the socket REMOTE (X1) (see Fig. 9) (For example via a remote control or with the aid of the plug with integrated ON/OFF switch: see Section 1.2 Ordering data).
- by a start command via the interface; see Section 4.
- For the power supply units offered or recommended by Leybold: If the contacts 7 and 8 at the REMOTE (X1) connector are closed the pump starts automatically when the DC voltage is switched on (provided parameter 12 is set to 0).

The turbomolecular pump accelerates. The green LED flashes. When the pump reaches normal operation the green LED lights up permanently.

### 3.2 Shutting down

Switch off the pump at the frequency converter.

- via contacts 7 and 8 of the socket REMOTE (X1) (see Fig. 9), if parameter 12 = 0.
- apply a stop command via the interface, if parameter 12 = 1 or 2.
- for the power supply units offered or recommended by Leybold switch off the DC voltage.

After switching off, the green status LED will flash until the rotor of the turbomolecular pump is at standstill. This may take several minutes. With the DC power supply off, the turbomolecular pump will act as a generator supplying the frequency converter with energy as indicated by the yellow power LED.

If a failure occurs the turbomolecular pump will be shut down automatically. The red LED at the frequency converter lights up.

To shut down the frequency converter, switch the pump off and wait until the rotor of the turbomolecular pump has arrived at standstill (green status LED off).

Then switch the mains power off and wait until the yellow power LED is off. Then only disconnect any cable connections.

In the case of an emergency shut down, the pump is switched off as described above. The rotor of the turbomolecular pump may be stopped faster by venting the pump; for this refer to the Operating Instructions for the pump.

---

### **3.3 Maintenance**

The frequency converter is maintenance free. Repairs must only be done by Leybold.

When removing a defective frequency converter from an installation, please note the information given in Chapter 3.2.

## **4 Interface description**

The frequency converter may be equipped with either of the following interfaces (optional):

- RS 232
- RS 485
- Profibus DP

The TURBO.DRIVE S is configured through the parameters according to the parameter list. Upon request we will provide information on the protocol used.

Note: Pxxx denotes parameter value xxx. For a list of the parameters please refer to Chapter 4.4.

The PC software "TURBO.DRIVE Server" and the display "Palm M100/105" allow convenient access by the user to the parameters of the frequency converter.

**Applications which can be implemented with the aid of the serial interface:**

<b>Application</b>	<b>Benefits to the customer</b>	<b>How to do it</b>
Networking of several pumps and other equipment	Savings relating to the costs for signalling cables	With Field Bus systems like RS485 or Profibus
Automation	Savings related to repetitive manual work	For example by a control computer
Avoidance of warnings and warnings before overload operation and early detection of a failing pump	<ul style="list-style-type: none"> <li>• Precise planning for maintenance</li> <li>• Improved reliability of sensitive production processes in a vacuum</li> </ul>	Monitoring of: <ul style="list-style-type: none"> <li>• Motor current P5</li> <li>• Ball bearing temperature P125 or P127</li> <li>• Motor temperature P7</li> <li>• Frequency converter temperature P11</li> </ul>
Standby operation	<ul style="list-style-type: none"> <li>• Extending the service life for the ball bearings</li> <li>• Cutting energy consumption</li> </ul>	Reducing the rotor's frequency through P24
Troubleshooting	Quick analysis of problems	Reading of error memories P171 and P176
Slow pressure control by changing the pumping speed	Dispensing with a flow controller	Changing the rotor frequency through parameter 24
Reducing the maximum motor current	Cost savings through smaller power supply units if peak loads can be reduced	With P17, maximum motor current
Starting the pump with a delay if a several consumers are connected to the same PSU	Cost savings through smaller power supply units if peak loads can be reduced	With P36, delay
Frequency converter as a simple pressure gauge, since motor current is dependent on the vacuum conditions	Dispensing with pressure gauges	Monitor motor current P5; second function for "Normal Operation" relay: relay switches as soon as the motor current threshold is tripped Adjust second function: P29 Set motor current threshold: P27
Lowering the normal operation threshold	Normal operating mode is attained faster, processes can be started faster	Reduce frequency threshold through P25

## 4.1 RS 232 interface

Standards	DIN 66020
Protocol	acc. to VDI/VDE 3689
Transmission rate	19200 baud fixed
Response delay	default setting 10 ms (parameter 180)
Address range	non-addressable
Max. cable length	5 m
Nominal voltage level (see also "Standards")	at the receiver logic "0": 3 ... 15 V logic "1": - 3 ... - 15 V
Interface connector	9 way Sub-D type, socket on the instrument (female) thread UNC4-40

Note: If on the controlling side an interface in accordance with the PC standard is present, then a commercially available straight through cable may be used.

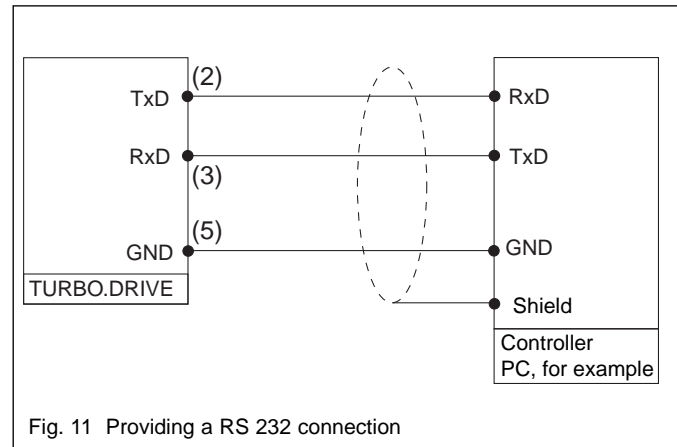
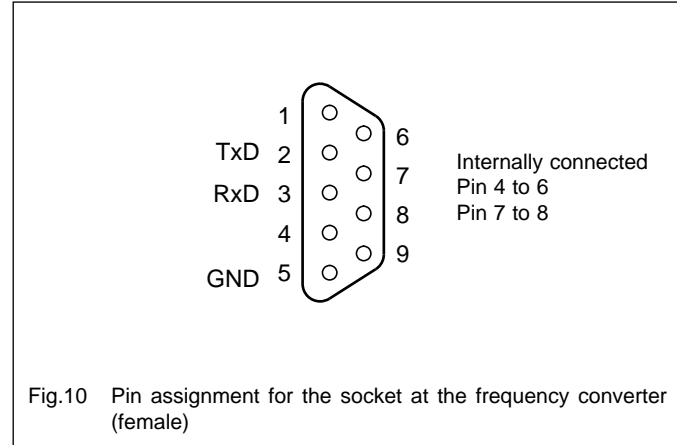

## 4.2 RS 485 interface

Standards	ISO 8482, EIA 485
Protocol	acc. to VDI/VDE 3689
Transmission rate	19200 baud fixed
Response delay	default setting 10 ms (parameter 180)
Address range	0 ... 15
Max. cable length	50 m (with bus termination)
Type of cable	2 wire twisted pair (twisted pair cable)
Differential voltage levels (see also "Standards")	logic "0": transmitter: 1.5 ... 5 V receiver: > 0.3 V  logic "1": transmitter: - 1,5 ... - 5 V receiver: ≤ - 0,3 V
Interface connector	9 way Sub-D type, socket on the instrument (female) thread UNC4-40

Note: After having changed the bus address through the rotary switch, the frequency converter must be switched off (yellow power LED off) and then on again so as to enable the new address setting.

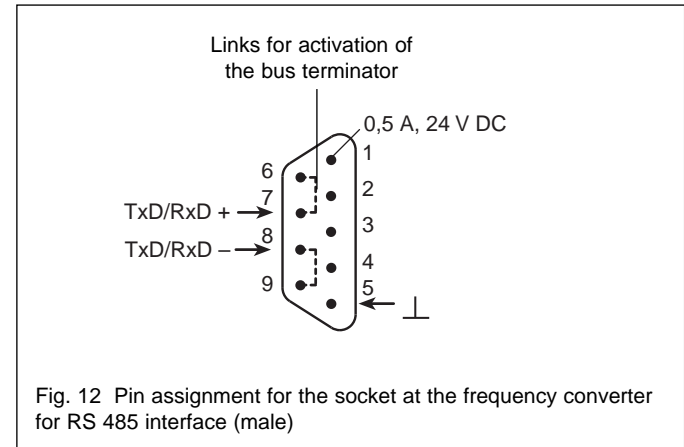

## 4.3 Profibus DP

The Profibus DP used has been defined in the standards EN 50170, DIN 19245-1, -3, VDI/VDE 3689.

For more information on the Profibus system:

"The Rapid Way to Profibus",  
Manfred Popp, Profibus Nutzerorganisation e.V., Germany  
P/N 4.072

Upon request we shall be pleased to provide detailed information on the hardware and the protocol used for the data.

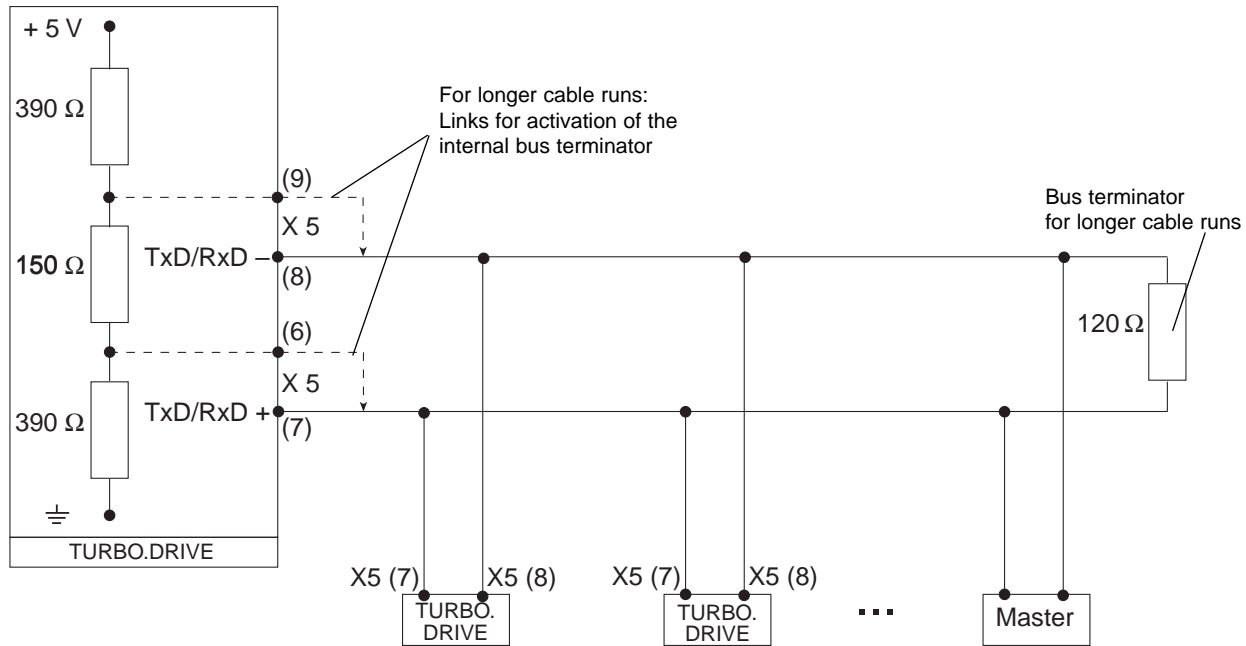

Fig. 13 Connection of a RS 485 bus



## 4.4 Parameter list

r = readable, w = writable

No.	Designation	Range	Unit	Default	Format	r/w	Description
0	Dummy parameter	-	-	-	U16		No function
1	Type of frequency converter	130 / 131	-	-	U16	r	TURBO.DRIVE S = 130 TURBO.DRIVE L = 131
2	Software version	2.x.x	-	-	U16	r	
3	Actual rotor frequency	0...1300	Hz	-	U16	r	The max. frequency depends on the pump type.
4	Actual converter supply voltage	18...30	V	-	U16	r	Nominal value for TURBO.DRIVE S: 24V
5	Setpoint for the motor current	0... 60	0.1A	-	U16	r	
7	Actual motor-temperature	0...150	°C	-	U16	r	Measured coil temperature for the motor
8	Permanently save the changed parameter data in the EEPROM	-	-	-	U16	w	A write command will cause the data to be saved. The parameter value itself is not processed and saved.
11	Actual converter temperature	0...150	°C	-	U16	r	Measured internal converter temperature
12	Operating mode for Start/Stop	0...2	-	0	U16	r/w	P12 = 0 (default): via REMOTE (X1); see Fig. 9 P12 = 1: via serial interface P12 = 2: Start: REMOTE (X1) at Start <b>and</b> serial interface sends Start signal Stop: REMOTE (X1) at Stop <b>or</b> serial interface sends Stop signal

No.	Designation	Range	Unit	Default	Format	r/w	Description
17	Max value setting for motor current	5 ... 75	0,1 A	*	U16	r/w	Maximum permissible motor current
18	Nominal pump frequency	750...1200	Hz	*	U16	r	Highest permissible frequency
19	Minimum setpoint frequency for the pump	375..600	Hz	*	U16	r	Lowest permissible frequency
20	Minimum frequency level	375..600	Hz	*	U16	r	When the pump is accelerating this frequency must be reached within the maximum passing time (P183).
23	Pump type	0..4	-	*	U16	r	0 = TW 220/150 1 = TW 700 (TURBO.DRIVE L freq. converter) 2 = TW 250S, T 180 3 = TW 70 H 4 = TW 300 / TW 300 H
24	Setpoint frequency	P19 ... P18	Hz	*	U16	r/w	Adjustable between P19 to P18
25	Frequency dependent normal operation level	0..100	%	90	U16	r/w	If P29 = 0: Defines the normal operation level. Normal operation if $P3 \geq P24 \times P25$
27	Motor current dependent normal operation level	5...75	0,1 A	20	U16	r/w	If P29 = 1: Defines the normal operation level. Normal operation if $P5 \leq P27$
29	Selection of the normal operation function	0 / 1	-	0	U16	r/w	Normal operation relay function: 0 = frequency dependent (see P25) 1 = current dependent (see P27)

\* specific values for each pump; see table of pumps, Chapter 4.5; r = readable, w = writable

No.	Designation	Range	Unit	Default	Format	r/w	Description
32	Maximum run up time	30...2000	s	720	U16	r/w	Max. permissible time during which the pump must attain the normal operation threshold (P24 x P25) with the start signal present
36	Start delay time	0...255	0.1 min.	0	U16	r/w	Pause time after the Start command until the pump's drive is started
125	Current bearing temp.	0...150	°C	-	U16	r	Measured bearing temperature (identical to P127)
127	Current bearing temp.	0...150	°C	-	U16	r	Measured bearing temperature (identical to P125)
132	Bearing temperature shutdown level	30...150	°C	*	U16	r	Max. permissible bearing temperature; P125 > P132 causes the pump to be switched off
133	Motor temperature shutdown level	30...150	°C	*	U16	r	Max. permissible motor temperature; P7 > P133 causes the pump to be switched off
171	Error code memory for the last 8 error events Error codes see error table 4.3	0...8		0	Array 0..7 U16	r	Sequential permanent memory; the last error code which has occurred is saved at the memory location with the index 0, the oldest is at index 7
176	Error operating hours memory for the last 8 error events	0...19 years	0.01 h	-	Array 0..7 U32	r	Analogous to P171 (error code memory)

\* specific values for each pump; see table of pumps, Chapter 4.5; r = readable, w = writable

No.	Designation	Range	Unit	Default	Format	r/w	Description
180	Response delay time	2...19	msec	10	U16	r/w	Pause time between received and transmitted USS protocol string of the frequency converter's serial interface RS 232 and RS 485. We recommend not to change the default setting (10 ms)
183	Max. passing time	10...2000	s	500	U16	r	Max. permissible time during which the pump must - with the start signal present - have passed through the critical speed range between 60 Hz and P20
184	Converter operating hours counter	0...19 Years	0,01h	-	U32	r	Totals the operating hours for the converter when the pump's drive is active
303	Pump status word	-	-	-	U16	r	Meaning of the bits: Bit 0 = 1 Normal operation Bit 1 = 1 Ready for switch on Bit 2 = 1 Speed is increasing Bit 3 = 1 Speed is dropping In case of an error P303 has the value of 0 (not ready to be switched on)
312	Cat. No. code	0 ... 65535	-	-	U16	r	800070V0002 = 7002 800070V0003 = 7003 etc.
315	Serial No. code	1 ... 231-1	-	-	U32	r	The 9 least significant bits of the original serial No.
316	Hardware identifier	0...100	-	-	U16	r	Hardware version index of the converter

r = readable, w = writable

## 4.5 Specific parameter data for the pumps

Type of pump	Pump designation	Nominal and setpoint frequency <b>P18 / P24</b>	Minimum setpoint frequency <b>P19</b>	Minimum frequency level <b>P20</b>	Max. motor current <b>P17</b>	Max. bearing temperature <b>P132</b>	Max. motor temperature <b>P133</b>
<b>P23</b>							
0	TW 220 / 150 TW 220/150/15	750	375	375	60	80	100
1	TW 700#	800	550	550	75	70	85
2	TW250S	860	450	450	45	80	100
3	TW 70 H	1200	600	600	45	67	90
4	TW 300 / TW 300 H	1000	500	500	60	80	100

# TURBO.DRIVE L frequency converter

## 4.6 Error codes for parameter P171

Code	Type of error	Description of the error
0	No error	–
1	Overspeed error	Nominal speed of the pump (P 18) has been exceeded by over 10%
2	Pass through time error	Max. time for passing through the critical frequencies of 60 Hz to P20 has been exceeded: 60 Hz < P3 < P20 after P183 has elapsed with the start signal present
3	Bearing temperature error	Maximum bearing temperature has been exceeded: P125 > P132; P127 > P132
4	Short circuit error	Short circuit in the pump's motor or the connecting cable
5	Converter temperature error	Maximum temperature for the converter has been exceeded: P11 > 75°C
6	Run up time error	Max. time after which the pump must enter its normal operation mode has been exceeded: P3 < P24 x P25 after P32 has elapsed with the start signal present
7	Motor temperature error	Maximum motor temperature has been exceeded: P7 > P133
8	Pump error	Pump could not be identified or no pump is connected.

---

## 5 Troubleshooting

Before you start searching for the source of the problem, you should carry out a few simple checks:

Are the connections in good working order?

- Mains connection,
- 24 V DC cable to the frequency converter,
- Connector cable between the frequency converter and the pump

Is the forevacuum pressure sufficient?

After having removed the cause for the error reset the error message at the TURBO.DRIVE S:

- In case of errors with error codes 1 to 7 by applying a STOP signal via the socket REMOTE (X1) or the serial interface or by switching the mains power off.
- In case of error code 8 by switching the mains power off (yellow POWER LED off).

The error codes can only be read if a serial interface is present.

The following table has been provided as a guide when determining the causes of errors.

<b>Malfunction</b>	<b>Possible cause</b>	<b>Corrective action</b>
<p>Red ERROR LED is on: Error code1: Overspeed error</p>	<p>EMC problems</p> <p>TURBO.DRIVE S faulty</p>	<p>Check connecting cable, insert it properly Switch the power supply voltage off and then on again Inform Leybold Service.</p>
<p>Red ERROR LED is on: Error code 2 + 6: pass through timer error and run up time error</p> <ul style="list-style-type: none"> <li>• Pump runs up too slowly</li> <li>• Pump loses its speed</li> </ul>	<p>Forevacuum or high-vacuum pressure too high.</p> <p>Gas volume too great.</p> <p>Power supply overloaded</p> <p>Bearing defective.</p>	<p>Check the forevacuum pump and use a different forevacuum pump if necessary.</p> <p>Seal leak; install a higher-capacity vacuum pump if necessary.</p> <p>Reduce the number of consumers or use a stronger power supply or switch on the consumers one after the other.</p> <p>Have the pump repaired (may be done only by a Leybold service technician).</p>
<p>Red ERROR LED is on: Error code 3 + 7: bearing temperature error and motor temperature error</p>	<p>Forevacuum pressure too high.</p> <p>Gas volume too great or leak in the system.</p> <p>Fan defective.</p> <p>Ambient temperature too high.</p> <p>Bearing defective.</p>	<p>Check the forevacuum pump and use a different forevacuum pump if necessary.</p> <p>Seal leak; install a higher-capacity vacuum pump if necessary.</p> <p>Replace the fan (may be done only by a Leybold service technician).</p> <p>Feed cooler air to the pump or install water cooling.</p> <p>Have the pump repaired (may be done only by a Leybold service technician).</p>



<b>Malfunction</b>	<b>Possible cause</b>	<b>Corrective action</b>
Red ERROR LED is on: Error code 4: Short circuit error	Short circuit in the pump's motor Short circuit in the connecting cable	Inform Leybold Service. Check to see if the connecting cable is undamaged, exchange it if required.
Red ERROR LED is on: Error code 5: converter temperature error	TURBO.DRIVE S integrated in the pump: Inadequate cooling of the pump; operation at too high loads  Separate TURBO.DRIVE S: Ambient temperatures too high Inadequate cooling of the TURBO.DRIVE S  Operation at too high loads	See corrective action for error code 3 + 7. (page 32)  Improve the cooling situation: Install a fan Ensure better thermal linking to the cooling surface and ensure a lower temperature at the cooling surfaces Avoid exposure to the heat generated by other equipment.  See corrective action for error code 3 + 7. (page 32)
Red ERROR LED is on: Error code 8: pump error TURBO.DRIVE S can not detect the type of connected pump.	Pump not connected to TURBO.DRIVE S Wrong connector cable pump - frequency converter. Power supply builds up the DC too slowly Power supply overloaded	Check connecting cable Use standard cable; see Section 1.2) (ConeNect doesn't work) Use power supply recommended by Leybold  Reduce the number of consumers when switching on or use a stronger power supply.

<b>Malfunction</b>	<b>Possible cause</b>	<b>Corrective action</b>
Yellow power LED is not on.	No DC power Internal SMD fuse has blown	Check cables and power supply. Inform Leybold Service. The following may cause a blown SMD fuse: <ul style="list-style-type: none"> <li>• DC power miswired</li> <li>• Disconnection of the DC cable while the pump was still rotating</li> <li>• Non-compliance with the note related to connecting several pump to a single power supply.</li> </ul>

<b>Malfunction</b>	<b>Possible cause</b>	<b>Corrective action</b>
<p>Turbomolecular pump does not start, ERROR LED does not light.</p>	<p>Operation mode set wrongly, e. g. with TURBO.DRIVE Panel or Server.</p> <p>Interface protocol error</p> <p>No communication via the serial interface.</p> <p>REMOTE connector (X1) connected wrongly.</p>	<p>Change parameter 12.</p> <p>Use USS protocol.</p> <p>Connect bus as shown in Section 4.</p> <p>Connect as shown in Fig. 9.</p>
<p>Turbomolecular pump produces loud running noises and vibrations.</p>	<p>Rotor out of balance.</p> <p>Bearing defective.</p>	<p>Have the rotor balanced (may be done only by a Leybold service technician).</p> <p>Have the bearing replaced (may be done only by a Leybold service technician).</p>
<p>Turbomolecular pump does not reach ultimate pressure.</p>	<p>Measurement instrument defective.</p> <p>Measurement sensors soiled.</p> <p>Leaks at the equipment, lines or the pump.</p> <p>Pump soiled.</p> <p>Forevacuum pump provides insufficient pumping speed or ultimate pressure which is too high.</p> <p>Frequency parameters programmed wrongly.</p>	<p>Inspect the measurement sensor.</p> <p>Clean or replace the sensors.</p> <p>Check for leaks.</p> <p>Have the pump cleaned (may be done only by a Leybold service technician).</p> <p>Check the ultimate pressure of the forevacuum pump and install a higher-capacity vacuum pump if necessary.</p> <p>Check parameters.</p>



## Declaration of Conformity

as per EG Low-Voltage Guidelines 73/23/EWG,  
Attachment III B

Product: TURBO.DRIVE S



**RIR-TDS2-NSR**

2000-12-07

We herewith declare sole responsibility for the product

1. Product: Inverter
2. Manufacturer: Indramat Refu GmbH  
Uracher Straße 91  
72555 Metzingen / Germany
3. Type: TURBO.DRIVE S, Cat. No.: 800070Vxxxx
4. including the following options: RS 232 interface, RS 485 interface,  
integrated Profibus DP, built on heat sink
5. from date of manufacture: 2000-12-01
6. Applicable standard: EN 61010 Part 1: Safety requirements for  
electrical equipment for measurement,  
control and laboratory use., 03/94  
  
EN 60204 Part 1: Safety of machinery -  
Electrical equipment of machines, 06/93

Metzingen, 2000-12-07

We reserve the right to make changes in the conformity  
declaration. Presently applicable edition can be obtained  
upon request.

### Indramat Refu GmbH

Uracher Straße 91 • D-72555 Metzingen  
Phone +49 (0) 71 23 / 9 69-0 • Fax +49 (0) 71 23 / 9 69-120

including the required accessories, as agreeing with EG guidelines  
72/23/EWG, and 93/68/EWG.

### Explanation

This product is a component intended for further assembly. Due to the  
features resulting therefrom, the product cannot initially meet require-  
ments made of finished products, machines or plants. It must thus be  
used for mounting/assembly only.

An evaluation of electrical and mechanical safety, environmental con-  
ditions (e.g., extrinsic objects and/or humidity) must be performed after  
mounting/assembly in the finished product.

The EMC characteristics of this product can change in a mounted/  
assembled state. An EMC check must thus be made for the finished  
product (final unit, machine or plant) by the manufacturer of the finis-  
hed unit, machine or plant.

Michael Kimmich  
Head of Quality Management

Stephan Scholze  
Head of Development





## Declaration of Conformity

as defined by the EMC guideline 89/336/EWG  
with revisions 91/263/EWG and 93/68/EWG

Product: TURBO.DRIVE S



**RIR-TDS2-EMV**

2000-12-07

We herewith declare sole responsibility for the product

1. Product: Inverter
2. Manufacturer: Indramat Refu GmbH  
Uracher Straße 91  
72555 Metzingen / Germany
3. Type: TURBO.DRIVE S, Cat. No.: 800070Vxxxx
4. including the following options: RS 232 interface, RS 485 interface, integrated Profibus DP, built on heat sink
5. from date of manufacture: 2000-12-01
6. Applied standards: EN 50081 Part 2: Electromagnetic compatibility (EMC) / Generic emission standard  
EN 50082 Part 2: Electromagnetic compatibility (EMC) / Generic immunity standard 06/93

meet the requirements outlined in the EG requirements on 89/336/ EWG (EMC guideline) with revisions 91/263/EWG and 93/68/EWG.

### Explanation

Maintaining the EMC guideline assumes an EMC adapted installation of component within the plant or machine.

Test were run using a typical construction in a test assembly that conforms with the standards. The legal requirements made of resistance to interference and resistance to emission of interference limit values and standards are outlined in the above-referenced documentation.

This Indramat Refu product is intended for installation into an end product. The test results are not applicable to every installed state in every end product. This declaration does not therefore guarantee the EMC characteristics of the end product.

Metzingen, 2000-12-07

We reserve the right to make changes in the conformity declaration. Presently applicable edition can be obtained upon request.

Michael Kimmich  
Head of Quality Management

Stephan Scholze  
Head of Development

### Indramat Refu GmbH

Uracher Straße 91 • D-72555 Metzingen  
Phone +49 (0) 71 23 / 9 69-0 • Fax +49 (0) 71 23 / 9 69-120

GA 05.223/4.02 - 12/2001





---

---

---

## **LEYBOLD VAKUUM GmbH**

Bonner Strasse 498 (Bayenthal)

D-50968 Cologne

Phone: +49 221 347-0

Fax: +49 221 347-1250

<http://www.leyboldvac.de>

e-mail: [documentation@leyboldvac.de](mailto:documentation@leyboldvac.de)