

Vacuum Solutions

Application Support

Service



LEYBOLD
VACUUM PRODUCTS INC.

Part Number 772-78-009 ■ Edition N

For Sales And Service Please Call

Provac Sales, Inc

Tel: 831-462-8900

Fax: 831-462-3536

www.provac.com



10-5.1

OF-1000 OIL FILTERING SYSTEM MANUAL

Operating Manual



		<h1>! WARNING</h1> <p>Death or serious injury can result from the improper use or application of this oil filter. If the pump or oil filter will be exposed to toxic, explosive, pyrophoric, highly corrosive, or other hazardous process gases including greater than atmospheric concentrations of oxygen, contact Leybold for specific recommendations.</p>

TABLE I -- OF-1000 TECHNICAL DATA

Gear Pump Motor	1/6 Hp, 115/208/230 Volts, 3.6/1.8 Amps, Single Phase, 50/60 Hz, 1425/1725 RPMs, with automatically resetting thermal overloads, wired for 115 Volts.
Gear Pump	0.7 gpm at 1725 RPM
Pressure Gauge	0-100 psig (0-700 K Pa)
Oil Pressure ⁺	See Section 3.2 for a detailed explanation.
Initial*	0 psig
For room-temperature oil#..	30 to 55 psig
For warm oil	5 to 30 psig
When element is clogged ...	>50 psig
Oil Capacity	
Single-canister model.....	3.75 quarts of hydrocarbon oil or 15 pounds of perfluoropolyether
Dual-canister model.....	7.5 quarts of hydrocarbon oil or 30 pounds of perfluoropolyether.
Flexible Hoses.....	4-feet long x 3/8" ID, Teflon with stainless steel braid
Dimensions	
Single-canister model.....	14" W x 14" L x 10 1/2" H
Dual-canister Model.....	14" W x 23" L x 10 1/2" H
Weight of Single-Canister Model without the Filter Element or the Oil	44.5 pounds
Maximum Run	OF-1000 can operate 10 to 15 feet away from the vacuum pump horizontally. Vertically, it can operate up to 5 feet above the pump; there is no restriction on the distance it can operate below the pump.

+These pressures are for the single canister model. The pressures for the dual-canister model are higher.

*The pressure rises as soon as the oil displaces any air in the OF-1000.

#This pressure gradually decreases as the vacuum pump approaches its operating temperature.

See the inside back cover for the warranty.

TRIVAC is a registered trademark of Leybold.

CONTENTS

Section	Title	Page
SECTION 1	INTRODUCTION	1
SECTION 2	EQUIPMENT UNPACKING.	2
SECTION 3	DESCRIPTION AND PRINCIPLES OF OPERATION	3
	3.1 General Description	3
	3.2 Oil Circulation	5
	3.3 Filtering Elements	8
	3.4 Perfluoropolyether Oil	9
SECTION 4	INSTALLATION	10
SECTION 5	START UP	17
SECTION 6	OPERATION	20
	6.1 Monitoring the Oil Pressure and Color	19
	6.2 Gas Bubbles in the Oil During Operation.	20
	6.3. Using One OF-1000 to Service Several Pumps	21
SECTION 7	ROUTINE MAINTENANCE	23
	7.1 Checking for Contamination	24
	7.2 Changing the Filtering Element	26
	7.3 Changing the Oil	32
	7.4 Checking the Oil Level	33
SECTION 8	TROUBLESHOOTING	34
SECTION 9	PARTS LIST	41
APPENDIX A	CONVERSION INSTRUCTIONS FOR E- AND DK- PUMP MODELS	48
	E- and DK- Pump Modification	48
APPENDIX B	INSTALLING A NEW MECHANICAL SEAL IN THE GEAR PUMP	51



LIST OF FIGURES

Figure	Title	Page
3-1	Side View of OF-1000	4
	Sketch of an OF-1000 Connected to a Vacuum Pump	12
4-1	Quick-Connects Assembly on Ends of Hoses	13
7-1	Top View of OF-1000	25
7-2	Filter Housing Assembly (898555)	29
9-1	Side View of OF-1000	42
9-2	Top View of OF-1000	44
9-3	Sectional View of Filter Housing	46
A-1	Drilling Modification to E and DK Pump for Oil Filtering System	50
B-1	Cross Section of the Gear Pump	52

LIST OF TABLES

Table	Title	Page
3-1	OF-1000 Specifications	5
6-1	Part Numbers for the Quick-Connect Stem, Elbow, and Adapters	21
8-1	Troubleshooting Chart	35

SECTION 1

INTRODUCTION

This manual contains all of the information that you need to safely install, start, operate, maintain, troubleshoot, and order parts for your OF-1000 oil filtering system.

The OF-1000 oil filtering system extends the life of the vacuum oil and of the vacuum pump by removing contaminants and heat from the oil. It can be used with TRIVAC "A" pumps. With minor modifications, you can also use it with E and DK series rotary piston pumps (see Appendix A). Aluminum oxide, particulate, Fullers Earth, and hydrophilic filtering elements are available for use in the OF-1000. See Section 3 for a detailed description of the OF-1000 and Section 3.3 for information on selecting the correct filter element for your application.

There are two models of the OF-1000: 1) a single-canister housing model and 2) a dual-canister model. There are three versions of each of these two models: 1) a standard version, 2) a version prepared for perfluoropolyether oil, and 3) a coated corrosive-series version prepared for perfluoropolyether oil. The coated version is referred to as the OF-1000C. Unless otherwise noted, all references to the OF-1000 in this manual apply to all three versions of the oil filtering system.

Check the nameplate on the OF-1000 pan to determine which version you have. The following lists the part number for each version.

Single-Canister Model	Part Number
Standard Version	898550
Version Prepared for Perfluoropolyether	898551
OF-1000C Coated Version Prepared for Perfluoropolyether	898561

Dual-Canister Model	Part Number
Standard Version	898552
Version Prepared for Perfluoropolyether	898553
OF-1000C Coated Version Prepared for Perfluoropolyether	898554

The top of the cover nut is painted brown on the OF-1000C versions to make it easy to identify.

"WARNING" statements are used in this manual to prevent injury to personnel; "CAUTION" statements are used to prevent damage to equipment; "NOTES" contain helpful information.



Numbers in parentheses refer to item numbers of parts in the parts list (see Section 9-2). These numbers are also used to identify parts on the figures.

WARNING: Ensure that your process gas is compatible with the OF-1000 materials. If the process gas isn't compatible, it could result in contaminated oil leaking out of the OF-1000 or air leaking into the OF-1000 and vacuum pump. See Sections 9-2 and 9-3 for a list of materials used in the OF-1000. Contact our factory for more information.

SECTION 2 EQUIPMENT UNPACKING

The filtering element isn't included with the OF-1000. You must purchase the filtering element separately and install it before using the OF-1000 (see Section 4). See Section 3.3 for information on selecting the correct filtering element for your process.

Proceed as follows to unpack the OF-1000 and check for shipping damage.

1. Inspect the outside of the shipping container for shipping damage. If you will be making a damage claim, keep the shipping container and packing materials.
2. Carefully unpack the OF-1000.
3. Inspect the OF-1000 for damages.
4. If you find any evidence of damage, proceed as follows:
 - a. Save the shipping container, packing material, and damaged part for inspection.
 - b. Notify the carrier that made the delivery within 15 days of delivery in accordance with Interstate Commerce regulations.
 - c. File a claim with the carrier for the damage. Any damage in transit is the responsibility of the carrier because all equipment is transported from our factory by private carriers.
 - d. If it is necessary to replace the damaged part, contact the our Order Service department.

SECTION 3

DESCRIPTION AND PRINCIPLES OF OPERATION

3.1 GENERAL DESCRIPTION

The OF-1000 oil filtering system extends the life of the vacuum oil and of the vacuum pump by removing contaminants and heat from the oil.

The OF-1000 can be used with TRIVAC® "A" pumps. With minor modifications to the pump, you can also use it with E and DK Series Rotary Piston Pumps (see Appendix A).

Single-canister and dual-canister OF-1000 models are available. The dual-canister model has two filter elements in series; it is usually used in processes that generate both particulates and acids. A particulate element is installed in the center canister and an activated alumina element is installed in the outer canister. The particulate element traps dirt particles that would otherwise clog the activated alumina element. See Section 3.3 for more information on filtering elements.

A standard version and two degreased versions are available for both the single-canister and the dual-canister models. The degreased versions are for use with perfluoropolyether oil (see Section 3.4). One degreased version is uncoated. The other, the OF1000C, is chemically treated with a fluorocarbon material to resist corrosion. After the metal surfaces are prepared, the fluorocarbon is sprayed and then baked onto the internal surfaces of the filter housing, gear pump, fittings, and the quick-connects so that it won't peel off.

The OF-1000 consists of a gear pump with motor, a pressure gauge, and an aluminum filter housing(s) mounted on a steel pan (see Figure 3-1). Rubber feet on the pan ensure quiet and vibration-free operation.

A sight glass/flow indicator (H12) allows you to observe the flow and clarity of the oil.

The OF-1000 hoses have quick-connects for easy installation and removal.

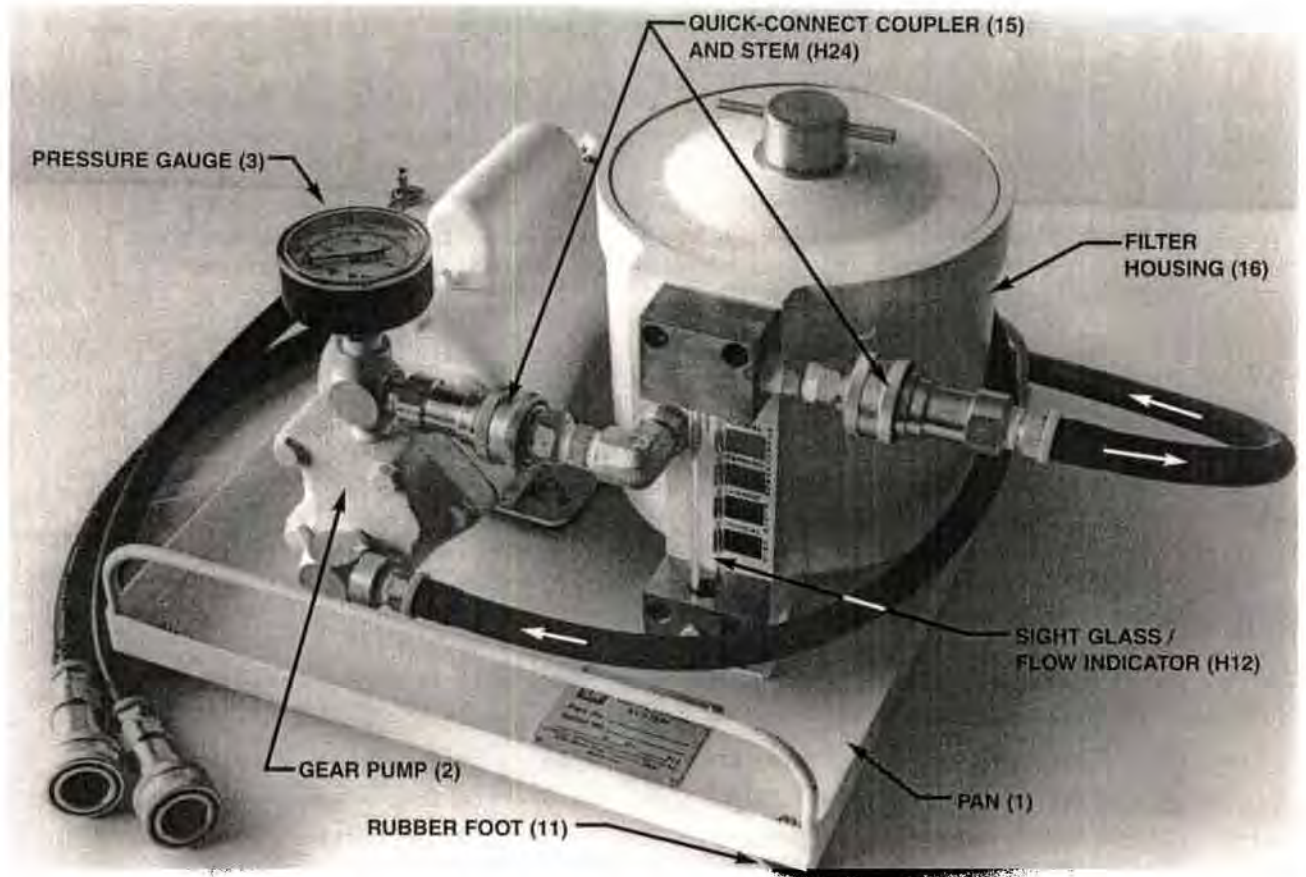

10-1.28

Figure 3-1 - Side View of OF-1000

Quick-connects are also used to connect the gear pump to the filter housing (see Figure 3-1). These quick-connects allow you to easily remove the filter-housing/filtering-element assembly from the OF-1000. If you keep a spare filter housing with a clean filtering-element on hand, the filter housing/filtering element assembly can be changed in a few minutes, thus minimizing down time for filter changes.

This feature also allows you to replace the filter housing/filtering element assembly in a clean room. The used assembly can then be removed from the clean room and be recharged with a new filtering element and oil to keep on hand for future changes. See Table 3-1 for specifications and Figure 3-1 for a photograph of the OF-1000.

TABLE 3-1 -- OF-1000 SPECIFICATIONS

Gear Pump Motor	1/6 Hp, 115/208/230 Volts, 3.6/1.8 Amps, Single Phase, 50/60 Hz, 1425/1725 RPMs, with automatically resetting thermal overloads, (wired for 115 Volts).
Gear Pump	0.7 gpm @ 1725 RPM
Pressure Gauge	0-100 psig (0-700 K Pa)
Oil Capacity	
Single-Canister Model	3.75 qts. of hydrocarbon oil or 15 pounds of perfluoropolyether.
Dual-Canister Model	7.5 qts. of hydrocarbon oil or 30 pounds of perfluoropolyether.
Oil Pressure ⁺	See Section 3.2.
Initial*	0 psig
For room-temperature oil#..	30 to 55 psig
For warm oil	5 to 30 psig
When element is clogged ...	>50 psig
Flexible Hoses	4-feet long x 3/8" I.D. Teflon with stainless steel braid
Dimensions	
Single-Canister Model	14" W x 14" L x 10-1/2" H
Dual-Canister Model	14" W x 23" L x 10-1/2" H
Weight of Single-Canister Model without the Filter Element or the Oil	44.5 pounds
Maximum Run	OF-1000 can operate 10 to 15 ft away from the vacuum pump horizontally. Vertically, it can operate up to 5 feet above the pump; there is no restriction on the distance it can operate below the pump.

+These pressures are for the single-canister models. The pressures for the dual-canister model are higher.

*The pressure rises as soon as the oil displaces any air in the OF-1000.

#This pressure gradually decreases as the vacuum pump approaches its operating temperature.



3.2 OIL CIRCULATION

During operation the OF-1000 recycles oil as follows (see Figure 3-1).

1. Contaminated vacuum oil is drawn from the vacuum pump's oil reservoir through the OF-1000 hose and into the gear pump.
2. The OF-1000 gear pump provides the pressure to circulate the oil through the OF-1000 system. The gear pump has an internal bypass valve that diverts all or part of the oil back into the inlet chamber of the gear pump if the pressure through the filter system exceeds approximately 55 psi.
3. An oil-pressure gauge mounted on the OF-1000 gear pump indicates the pressure of the oil flowing through the filter element. The pressures listed below are for the single-canister models; the corresponding pressures for the dual-canister models are higher.

0 psig	The gauge will read 0 psi until the oil displaces any air that may be in the OF-1000.
30 to 55 psig	The pressure will rise to 30 to 55 psi while the OF-1000 is filtering room temperature oil. This pressure will gradually decrease as the vacuum pump approaches its operating temperature.
5 to 30 psig	The normal operating pressure after the OF-1000 is warm is 5 to 30 psig.
>50 psig	If the pressure is above 50 psig when the system is at its operating temperature and has a new filtering element and relatively clean oil, it means that the filtering element may be partially clogged or that there may be a flow restriction downstream of the gauge.

4. The gear pump forces the contaminated oil through the quick-connects into the side of the filter housing.

5. Inside of the filter housing, the oil is forced inward through the filtering element (see Section 3.3) then up the center of the housing to the top where it flows through the four holes in the cover nut, and finally down through the center tube (see Figure 9-3). Forcing all of the oil to the top of the filter housing ensures that any air trapped there is removed.
6. The clean oil then flows out of the bottom of the filter housing up through the sight glass/flow indicator on the side of the housing, and out of the filter housing.
7. For single-canister models, the oil then returns to the oil-fill port of the vacuum pump through the OF-1000 hose.

For dual-canister models, the oil flows out of the center canister and into the outer canister where it is filtered a second time before returning to the vacuum pump.

The sight glass/flow indicator on the filter housing gives a visual indication of flow and allows you to monitor the color and appearance of the filtered oil. The actual flow depends on the oil viscosity at pump operating temperature and the specific gravity of the particular oil that you are using. When the oil is cold, the float should be at the top of the sight glass/flow indicator. If the float nears the bottom of the sight glass/flow indicator during operation it means that the OF-1000 filtering element needs to be changed, that there is a flow restriction in the OF-1000, or that the vacuum pump is running hot.

The standard OF-1000 versions (for hydrocarbon oils only) have a color chart attached to the filter housing. Use the color chart as a guide for determining when the filter element needs to be changed. OF-1000 versions prepared for extreme-corrosive service don't have this chart.



3.3 FILTERING ELEMENTS

You have a choice of Aluminum Oxide, Hydrophilic, Fullers Earth, or Particulate filtering elements (see Section 9-1 for ordering information).

For the dual-canister models, two filter elements are used in series. Usually a particulate element is used in the center canister and a activated alumina element in the outer canister. The particulate element removes dirt particles from the oil thus protecting the alumina element from becoming clogged with particulates.

The Aluminum Oxide filter effectively degasses the oil and is an outstanding particulate filter. It also removes Lewis acids, polar compounds, solvents, and mineral acids such as HCl and HF.

The Particulate filter is a pleated paper element that traps particulates as small as 10 microns.

The Hydrophilic element is best for removing particulates, water, and mild acids. This element works by absorbing moisture and any substance associated with the moisture. However, moisture must be present for the hydrophilic element to be effective.

The Fullers Earth element adsorbes acids.

3.4 PERFLUOROPOLYETHER (PFPE) OIL

Perfluoropolyether (PFPE) is an inert vacuum oil used when pumping extremely corrosive or reactive gases. If contaminants mix with the PFPE, the resultant mixture has poor vapor pressure and lubricating qualities. If Lewis acids contaminate PFPE at high temperatures, the oil will break down. See "Engineering Notes on Vacuum Pump Oils" or the LHK publication "Perfluorized Polyethers for Vacuum Pumps" (GA 7.009) for more information on PFPE vacuum oils.

The OF-1000 is ideally suited for vacuum pumps using PFPE oil. The Activated Alumina filtering element removes Lewis acids in addition to removing corrosive contaminants. The small oil capacity (see Table 3-1) minimizes your investment in PFPE.

When using PFPE oils, the vacuum pump and OF-1000 must be kept completely free of all hydrocarbon oils, solvents, greases, and other hydrocarbon substances for the following reasons:

- o Hydrocarbons could react with the process gas to create a fire or explosion hazard, and
- o PFPE and hydrocarbon oils emulsify when they come in contact with each other.

As mentioned previously, there are two versions of both OF-1000 models which are prepared for use with PFPE oil by degreasing. One version is uncoated and the other is coated. The coated version is referred to as the OF-1000C Corrosive Series.

The filter housing, gear pump, fittings and the quick-connects on the OF-1000C are chemically treated with a fluorocarbon material to resist corrosion. After preparing the metal, the fluorocarbon is sprayed and then baked onto the metal surfaces so that it won't peel off.



SECTION 4
INSTALLATION

WARNINGS:

- | | |
|-----------------------|-------------------------------------------------------------------------------------------------------------------------------------------------------------------------------------------------------------------------------------------------------------------------------------------------------------------------------------------------------------------------------------------------------------------------------------------------------------------------------------------------------------------------------------------------------------------------------------------------------------------------------------------------------------------------------------------------------------------------|
| Hazardous gases | If the vacuum pump and/or OF-1000 has been used on corrosive, toxic, hazardous, or volatile gases, take proper safety precautions to protect personnel a) before removing the plugscrews or inlet and exhaust lines from the vacuum pump, b) before removing the OF-1000 quick-connects, and c) before removing the cover from the OF-1000 filter housing. Proper precautions could include inert gas purging before and after you drain the oil to sweep hazardous gas from the vacuum pump or optional inlet and exhaust filters; gloves or protective clothing to avoid skin contact with toxic or highly corrosive substances; specially ventilated work areas; fume hoods; safety masks; breathing apparatus; etc. |
| PFPE-prepared OF-1000 | If you will be using perfluoropolyether (PFPE) oil, you must use an OF-1000 and vacuum pump that are specially prepared for perfluoropolyether. See Section 3.4 and contact our factory for more information. |
| Glass sight glass | Use care when working near the sight glass. If you break this glass, oil will squirt out. |

You can special order longer hoses if you need to operate the OF-1000 farther than 4 feet away from the vacuum pump. With the longer hoses, the OF-1000 can operate as far as 10 to 15 feet horizontally away from the vacuum pump.

It isn't necessary to bolt down the OF-1000. however, if you wish to secure it in place, replace the bolt in the center of each rubber foot with a bolt that is long enough to secure the OF-1000 to your frame or platform. Don't remove the rubber feet (see Figure 3-1).

The filtering element isn't included with the OF-1000. You must purchase the filtering element separately and install it before using the OF-1000 (see Section 4). See Section 3.3 for information on selecting the correct filtering element for your process.

If the OF-1000 is 5 feet or more above the vacuum pump, it is sometimes necessary to prime the gear pump on the OF-1000 before it will start (see Section 5).

Proceed as follows, to install the OF-1000 onto a TRIVAC vane pump. See Appendix A if you will be using the OF-1000 with an E or DK Series Rotary Piston Pump.

1. If not already done, install a new filtering element and clean oil as follows. On a dual-canister OF-1000, install a filter element into each of the two canisters.

- a. **WARNING:** Don't remove the cover from the filter housing unless the gear pump is turned off.

Unscrew the top nut and carefully remove the cover from the filter housing (see Figure 7-2).

- b. Install the correct filtering element (see Section 3.3) into the filter housing ensuring that the element is seated properly around the bottom ring of the housing. If the filtering element has a handle, the handle should face up.
- c. Pour the correct vacuum oil (see the pump identification plate or manual) into the center and outside of the filtering element until the oil level is just below the machined step in the housing (see Figure 9-3).
- d. Install the cover onto the filter housing as follows:
 - (1) A new cover O-ring comes with each filtering element. Coat the O-ring with the proper oil and install the new O-ring (H5) onto the rim of the cover; the cover will be difficult to remove if the O-ring hasn't been coated with oil.
 - (2) **IMPORTANT:** Failure to seat the cover onto the filtering element could result in oil bypassing the filtering element. An improperly installed cover could also result in an oil leak.

Fit the cover onto the top of the filter housing and begin tightening the top nut. The cover tilts slightly as it passes the lead-in chamfer of the housing. Straighten the cover and then continue tightening the nut. It may be necessary to straighten the cover several times before it is seated on the gasket on top of the filtering element. Tighten the cover hand-tight (see Figure 9-3); don't use a wrench or channel lock pliers to tighten the top nut.

A properly installed cover will be approximately 1/16 to 3/16 inch below the top rim of the filter housing. If the cover is less than 1/16 inch below the rim of the housing, it means that the filtering element isn't installed properly.

- e. Mark the installation date onto the label that came with the filtering element; then attach the label to the filter-housing cover.

2. Shut down the vacuum pump.

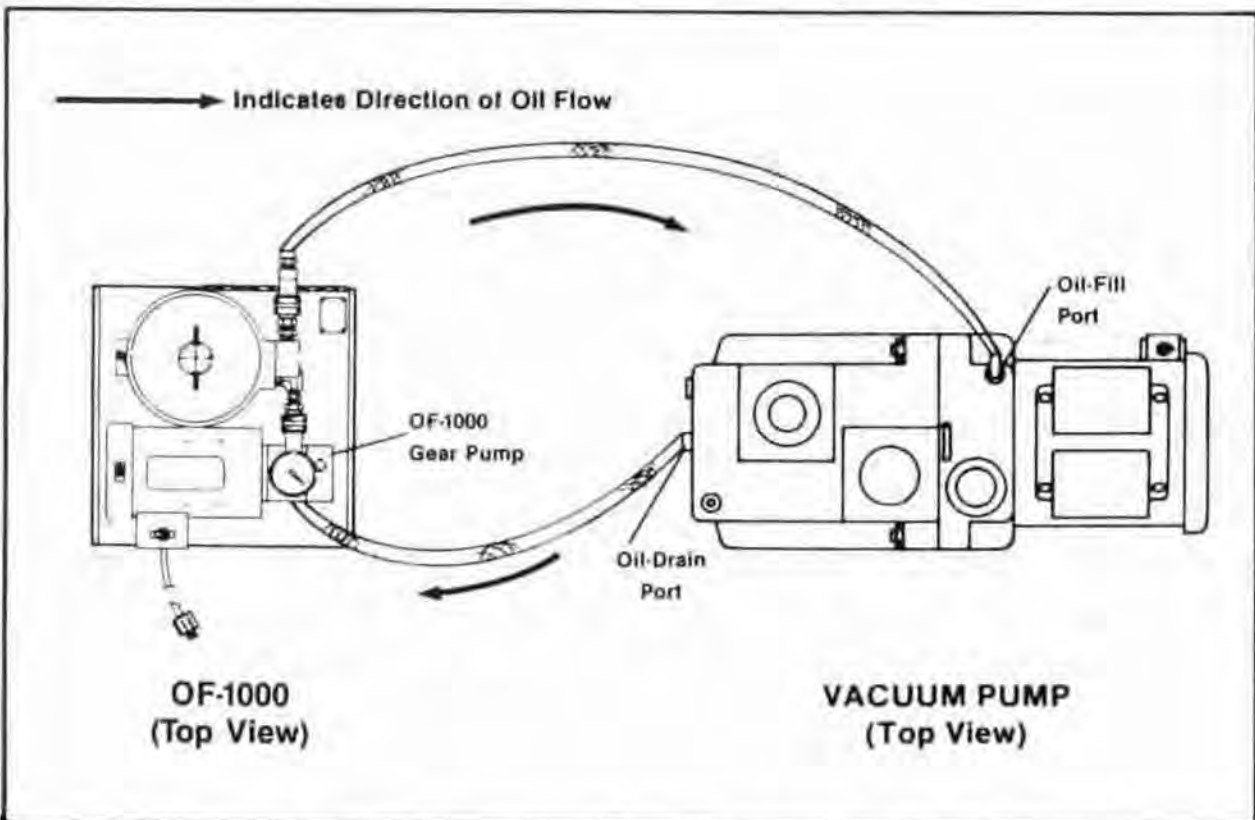

Sketch of an OF-1000 Connected to a Vacuum Pump

3. Remove the oil-fill and oil-drain plugscrews and drain the oil from the vacuum pump.
4. Install the quick-connect stem/elbow/gasket assembly (20/21/22) into the oil drain port of the vane pump as follows (see Figure 4-1).
 - a. Remove a quick-connect stem/elbow assembly (20/22) from one of the OF-1000 hoses (18) by pulling back on the spring-loaded quick-connect coupler (15) and pulling the stem (20) away from the coupler (see Figure 4-1).
 - b. Place the gasket (Part No. 239-55-165) from the vacuum pump's oil drain/fill plugscrews onto the elbow (22) on the quick-connect stem (20) (see Figure 4-1).
 - c. Screw the stem/elbow/gasket assembly into the oil-drain port of the vacuum pump.
5. Pour the correct vacuum oil through the oil-fill port of the vacuum pump until the oil level reaches the top of the vacuum pump's oil sight glass.
6. Repeat Step 4 except install a quick-connect stem/elbow/gasket assembly into the oil-fill port of the vacuum pump.

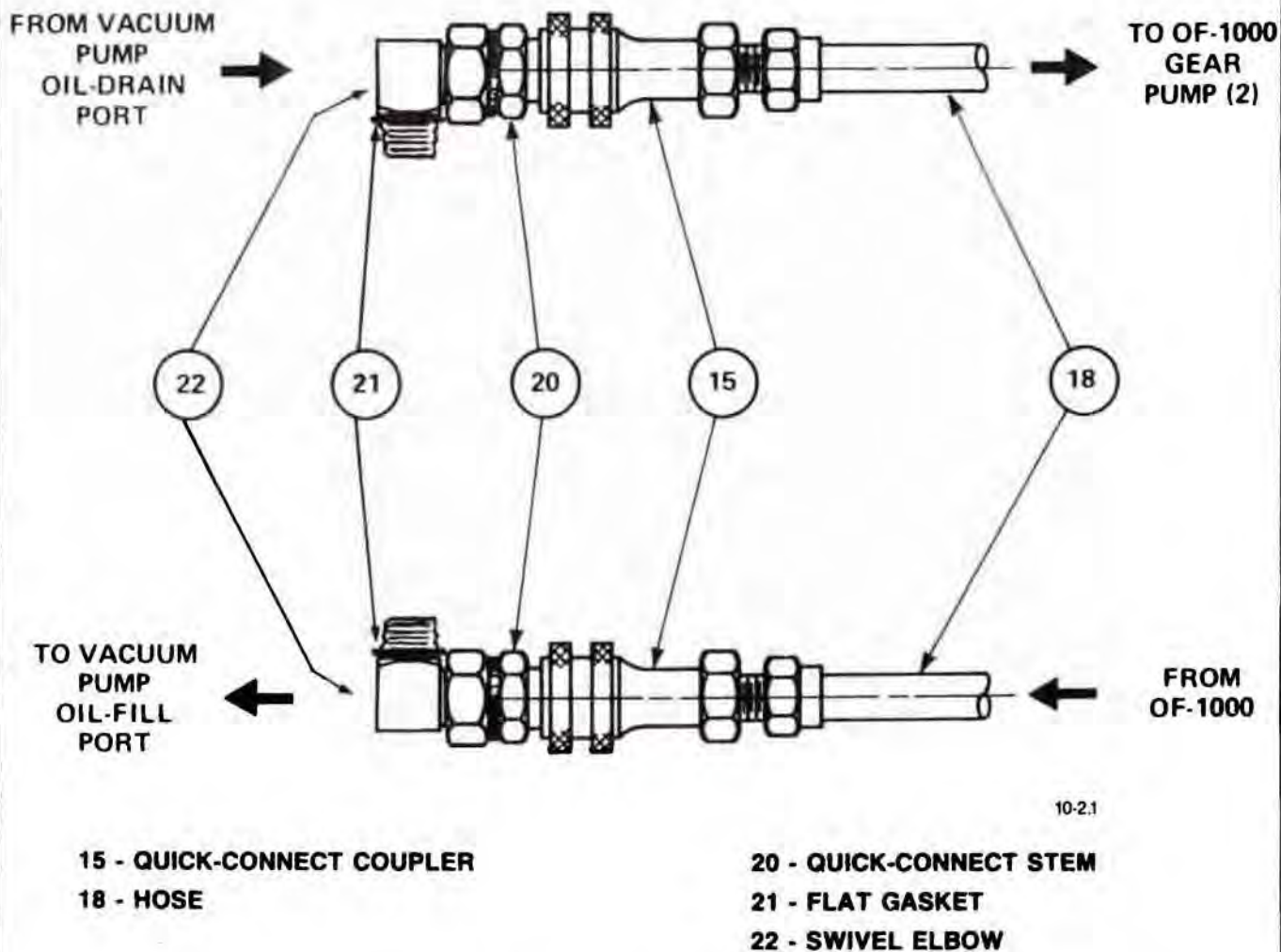

Figure 4-1 - Quick-Connect Assembly on Ends of the Hoses

7. CAUTION: Failure to connect the OF-1000 hoses to the correct oil ports on the vacuum pump could result in overfilling of the vacuum pump with oil.

Connect the OF-1000 hoses as follows:

- a. Connect the hose from the bottom of the OF-1000 gear pump to the quick-connect stem (20) on the vacuum pump's oil-drain port.
- b. Connect the hose from the OF-1000 filter housing to the disconnect stem (20) on the vacuum pump's oil-fill port (see Figure 7-1).



8. **NOTE:** The standard single-phase motor on the gear pump can run at 115 or 208, 220/230 volts at 50 or 60 Hz.* To change the voltage of the motor, install the appropriate linecord and use the wiring diagram inside of the motor junction box to change the connections in the motor junction box.

CAUTION: Failure to check the direction of rotation of the gear-pump motor after making any changes to the electrical connections can result in a) overfilling of the vacuum pump, and b) the gear pump being damaged from pumping air.

Make the electrical connection and check the direction of motor rotation as follows (see Figure 7-1):

- a. Connect the OF-1000 to a power outlet that matches the voltage requirements of the gear-pump motor (2) (see motor nameplate).
- b. Switch ON the OF-1000 momentarily to check the direction of rotation. Looking from the fan end of the gear-pump motor (2), the motor fan should turn counterclockwise.
- c. If the fan rotates clockwise, disconnect the power and correct the rotation by reversing two of the input leads in the motor junction box (see the motor nameplate tag).

* A gear pump with an explosion proof motor can also be supplied on request.

SECTION 5

START-UP

WARNING:

After installing a new filtering element, oil displaces air trapped in the element. This air bubbles through the OF-1000 sight glass and then into the vacuum pump before being expelled from the pump's exhaust port. Normally, this entrapped air doesn't cause a problem. However, if you are pumping pyrophoric gases, it could react with the pyrophoric gas and cause an explosion or fire. Before pumping pyrophoric gas, seal the pump's inlet, switch ON the OF-1000, and run the pump with nitrogen purging for 1/2 hour to allow all of the trapped air to be exhausted from the oil filter and vacuum pump.

If the OF-1000 is 5 feet or more above the vacuum pump, it is sometimes necessary to prime the gear pump on the OF-1000 before it will start. To prime the gear pump, remove the pressure gauge, fill the gear pump with the correct vacuum oil, and reinstall the pressure gauge (see Figure 3-1).

The oil pressures change as follows during start-up. The pressures listed below are for the single-canister models; the corresponding pressures for the dual-canister models are higher.

- | | |
|---------------|--------------------------------------------------------------------------------------------------------------------------------------------------------------------------------------|
| 0 psig | On cold start-up, the OF-1000 oil-pressure gauge reads 0 psig and then increases as air in the OF-1000 is displaced by oil. |
| 30 to 50 psig | Once the air is displaced, the pressure is 30 to 50 psig as the OF-1000 filters room temperature oil; then, the oil pressure decreases as the oil warms and its viscosity decreases. |
| 5 to 30 psig | When the pump reaches operating temperature, the normal oil pressure is in the 5 to 30 psig range. |
| >50 psig | If the pressure then increases above 50 psig, it means that the filter element is clogged and should be changed or that flow is restricted downstream of the gear pump. |

Proceed as follows to start the system:

1. Ensure that the OF-1000 hoses (18) are connected correctly.
2. **CAUTION:** Don't start the OF-1000 without oil in the vacuum pump or in the OF-1000 filter housing.

Switch ON the OF-1000 using the toggle switch on the gear pump motor (see Figure 7-1).

3. Check the OF-1000 filter housing for oil leaks. If there is any leakage, tighten the top nut by hand until the leak stops (see Figure 7-2).
4. As the air is displaced from the OF-1000, the oil level in the vacuum pump decreases.

Once the pressure on the OF-1000 gauge reaches 30 to 50 psig refill the vacuum pump as follows:

- a. Remove the extra oil-fill plug from the top of the vacuum pump.
- b. Pour the correct vacuum oil (see vacuum pump identification plate or manual) into the vacuum pump's oil-fill port until the oil level reaches the middle of the vacuum pump's oil-sight glass.
- c. Reinstall the oil-fill plug and switch ON the vacuum pump.
- d. After the vacuum pump has run for 30 minutes, recheck the oil level in the vacuum pump's sight glass; the oil level should be near the middle of the sight glass while the vacuum pump is running.
- e. If the oil level is low, turn off the vacuum pump, and repeat Steps 4a through 4c to add some additional oil.

SECTION 6

OPERATION

WARNINGS:

Hazardous gas Death or serious injury can result from the improper use or application of this oil filtering system. If the oil will be exposed to toxic, explosive, pyrophoric, highly corrosive, or other hazardous process gases including greater than atmospheric concentrations of oxygen, contact Leybold for specific recommendations.

Oil leak Process gas is often entrained in the vacuum oil. If the process gas is hazardous, you must take special safety precautions when handling the oil (see Section 7). If an oil leak develops, repair it immediately to prevent the contaminated oil from leaking from the vacuum pump or oil filtering system.

Compatibility of process gas with OF-1000 materials Ensure that your process gas is compatible with the OF-1000 materials. If the process gas isn't compatible, it could result in contaminated oil leaking out of the OF-1000 or air leaking into the OF-1000 and vacuum pump. See Sections 9-2 and 9-3 for a list of materials used in the OF-1000. Contact our factory for more information.

Removing the cover during operation Removing the cover from the filter housing while the OF-1000 is running could result in contaminated oil squirting out of the filter housing.

Glass sight glass Use care when working near the sight glass. If you break this glass, oil will squirt out. If the vacuum pump is exposed to hazardous gas, the oil could also be hazardous.

CAUTION: Don't allow the OF-1000 to sit for more than three days with contaminated oil in it or the gear pump may begin to corrode.

See Section 5 for the start-up procedure and Section 7 for the necessary routine maintenance.



6.1 MONITORING THE OIL PRESSURE AND COLOR

Check the pressure reading on the OF-1000 oil-pressure gauge and check the appearance of the oil through the OF-1000 sight glass/flow indicator every day (see Figure 9-1).

If the oil pressure of the single-canister models is in the 50 to 55 psi range while the pump is at operating temperature, it usually means that the filtering element is clogged and should be changed (see Section 7). The corresponding pressure for the dual-canister models is higher.

If the oil pressure reading is low but the oil has an unusual color or odor, is dark, contains particles, or appears dirty or turbid, change the filtering element (see Section 7). Use the color chart on the filter housing as a guide in determining whether or not to change the filtering element. OF-1000 versions that are prepared for extreme corrosive service don't have this color chart. When using the Activated Alumina or Fullers Earth filtering element, it is normal for the oil to become lighter in color over time.

An incorrectly adjusted bypass valve can also cause the oil pressure to stay low even though the oil is contaminated. See Symptom 6c of the troubleshooting chart for instructions on adjusting the bypass valve.

6.2 GAS BUBBLES IN THE OIL DURING OPERATION

During normal operation, gas bubbles may appear in the OF-1000 sight glass. An occasional spurt of bubbles (several seconds apart) may come from exhaust gases or process gases entrained in the vacuum oil. This is common with the TRIVAC "A" vane pump because of the churning action of its oil slinger. To determine if entrainment is the source of the bubbles, switch off the OF-1000 for a few minutes and check if foam is visible above the oil level in the vacuum pump's sight glass. If foam is visible, then entrainment is the source of the bubbles.

Continuous bubbles in the OF-1000 sight glass indicates an air leak in the OF-1000 hose connected to the vacuum pump's oil-drain port or in the suction side connections of the OF-1000 gear pump. If air won't react with the process gases, then there is no danger in allowing the bubbles to continue to flow. If the vacuum pump is exposed to pyrophoric gases, you must immediately disconnect the OF-1000 from the process and eliminate the air leak!



TABLE 6-1
PART NUMBERS FOR THE QUICK-CONNECT STEM, ELBOW, AND ADAPTERS

Item No.	Pump Model	Qty. Needed for Each Additional Pump	Description	Material	Part Number
20	All Models	2	3/8-inch FNPT quick-connect stem	Steel	721-52-001
				Stainless Stl	725-54-024
22	TRIVAC	2	3/8-inch NPT to M16 x 1.5 mm swivel elbow adapter	Stainless Steel	725-54-304
N/A	E & DK (see Appendix A)	2	3/8-inch NPT close nipple	Stainless Steel	725-57-001

SECTION 7
ROUTINE MAINTENANCE

WARNINGS:

- | | |
|---------------------------------|-------------------------------------------------------------------------------------------------------------------------------------------------------------------------------------------------------------------------------------------------------------------------------------------------------------------------------------------------------------------------------------------------------------------------------------------------------------------------------------------------------------------------------------------------------------------------------------------------------------------------------------------------------------------------------------------------------------------------|
| Hazardous gases | If the vacuum pump and/or OF-1000 has been used on corrosive, toxic, hazardous, or volatile gases, take proper safety precautions to protect personnel a) before removing the plugscrews or inlet and exhaust lines from the vacuum pump, b) before removing the OF-1000 quick-connects, and c) before removing the cover from the OF-1000 filter housing. Proper precautions could include inert gas purging before and after you drain the oil to sweep hazardous gas from the vacuum pump or optional inlet and exhaust filters; gloves or protective clothing to avoid skin contact with toxic or highly corrosive substances; specially ventilated work areas; fume hoods; safety masks; breathing apparatus; etc. |
| Removing cover during operation | Removing the cover from the filter housing while the OF-1000 is running could result in contaminated oil squirting out of the filter housing. |
| Glass sight glass | Use care when working near the sight glass. If you break this glass, oil will squirt out. If the vacuum pump is exposed to hazardous gas, the oil could also be hazardous. |
| Installing new hoses | If you must install new hoses, be sure to use teflon hoses with stainless steel braid and a conductive core (see Item 18 in Section 9-2). The static generated by the oil flow may arc and cause oil leaks in the standard hoses or fittings. The conductive core prevents this arcing. |
| Factory repair | Before sending an oil filtering system or pump to our factory or to one of our service centers, notify us of any toxic or other harmful products that may be in the pump, its oil, or its filters. |



7.1 CHECKING THE OIL FOR CONTAMINATION

Check the pressure reading on the pressure gauge (see Figure 7-1) and the appearance of the oil through the sight glass/flow indicator (H12) (see Figure 9-1) every day.

The pressure range of the gauge is 0 to 100 psi. This is NOT the fully usable range of the filtering element. When the gauge reads 50 to 55 psi while the pump is at operating temperature, it usually means that the filtering element is clogged and should be changed (see Section 7.2). For the dual-canister models, the corresponding pressure is higher.

If your process doesn't generate large amounts of particulates, watch for other indicators to determine when to change the filtering element. For example, if your process generates acids but very few particulates, the oil-pressure could be low even through the neutralizing capacity of the filtering element is exceeded. To determine when to change the OF-1000 filtering element in these cases, observe the appearance of the oil through the OF-1000 sight glass/flow indicator (H12) and/or test the oil. A high ultimate pressure for the vacuum pump is another indication that the filtering element may need to be changed.

The OF-1000 filtering element needs to be changed if the oil in the OF-1000 sight glass/flow indicator has an unusual color or odor, is dark, contains particles, or appears dirty or turbid. Use the color chart on the filter housing as a general guide for determining if the filtering element needs to be changed (see Section 7.2). OF-1000 versions that are prepared for extreme-corrosive service don't have the color chart.

Use either the neutralization number test (ASTM Method D 664 or D 974) or the INLAND test kit* to test your oil for acidity. The INLAND test tells you whether or not the oil is too acidic; whereas, the neutralization number test quantifies the exact acidity of the oil. To obtain a good sample for testing acidity, turn off the gear pump, disconnect the hose (18) from the filter housing and catch the few drops of oil that drip out of the quick-connect coupler (15) (see Figure 7-1). If the neutralization number of hydrocarbon oil exceeds 1 mgKOH/gram, it should be changed.

An incorrectly adjusted bypass valve can also cause the oil pressure to stay low even though the oil is contaminated. See Symptom 6c of the troubleshooting chart for instructions on adjusting the bypass valve.

*The Inland test kits are available from Inland Vacuum Industries, Inc, Churchville, NY.

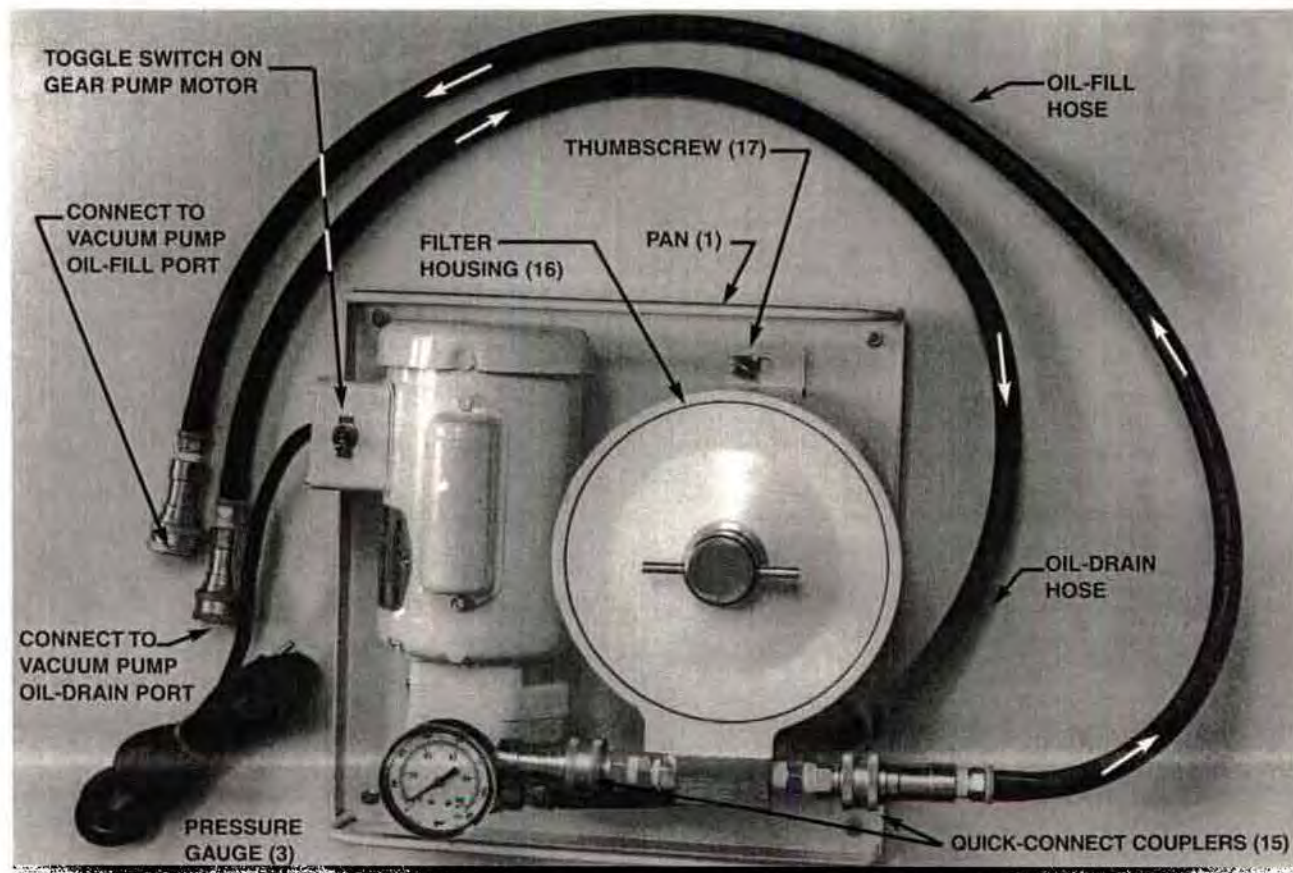

Figure 7-1 - Top View of the OF-1000



7.2 CHANGING THE FILTERING ELEMENT

WARNINGS:

See the warnings at the beginning of Section 7 before proceeding.

After installing a new filtering element, oil displaces air trapped in the element. This air bubbles through the OF-1000 sight glass and then into the vacuum pump before being expelled from the pump's exhaust port. Normally, this entrapped air doesn't cause a problem. However, if you are pumping pyrophoric gases, it could react with the pyrophoric gas and cause an explosion or fire. Before pumping pyrophoric gas, seal the pump's inlet, switch ON the OF-1000, and run the pump with nitrogen purging for 1/2 hour to allow all of the trapped air to be exhausted from the oil filter and vacuum pump.

See Section 7.1 to determine if the filtering element needs to be changed.

The dual-canister models have two filtering elements to change.

It takes only a few minutes to change the filtering element if you keep a spare filter housing containing a new filtering element (see Section 3.3) and clean vacuum oil on hand.

Proceed as follows to change the filtering element:

1. Switch off the OF-1000's gear pump motor (see Figure 7-1).
2. Allow the pressure on the OF-1000 gauge to reach 0 psi (see Figure 7-1).

3. Remove the hose from the filter housing by pulling back on the quick-connect coupler (15) (see Figure 7-1); a few drops of oil will drip from the quick-connects when they are removed.

4. Remove the filter housing from the pan as follows:
 - a. Loosen the thumbscrew that secures the filter housing to the pan (see Figure 7-1).

 - b. Pull back on the spring-loaded collar of the gear pump's quick-connect coupler (15) while sliding the filter housing away from the gear pump (see Figure 7-1).

5. If you don't have a spare filter housing, skip Step 5 and proceed to Steps 6 to change the filtering element.

If you have a spare filter housing containing a new filtering element and oil, proceed as follows to install the spare housing onto the pan:

- a. Start but don't tighten the thumbscrew into its threaded hole in the pan (see Figure 7-1).

- b. Position the filter housing onto the pan so that the housing's quick-connect stem (H24) aligns with the gear pump's quick-connect coupler (15) and so that the feet align with the holddown clip and thumbscrew (see Figures 7-1 and 7-2).



Section 7.2, Step 5 continued

- c. Pull back the spring-loaded collar on the gear pump's coupler while sliding the filter housing in place on the pan. Once the filter housing is in place, release the spring-loaded collar to connect the coupler to the stem. The front foot of the housing should be under the holddown bracket and the thumbscrew should be in the slot in the back foot.
- d. Tighten the thumbscrew that secures the filter housing to the pan (see Figure 7-1).
- e. Reconnect the hose to the filter housing's quick-connect stem (H24) (see Figures 7-1 and 7-2).
- f. Mark the installation date on the label that came with the filtering element and attach the label to the filter-housing cover.
- g. Do the steps in Section 5 to start the OF-1000 and adjust the oil level.
- h. Check the filter housing for oil leaks. If there is any leakage, tighten the top nut until the leak stops (see Figure 7-2).

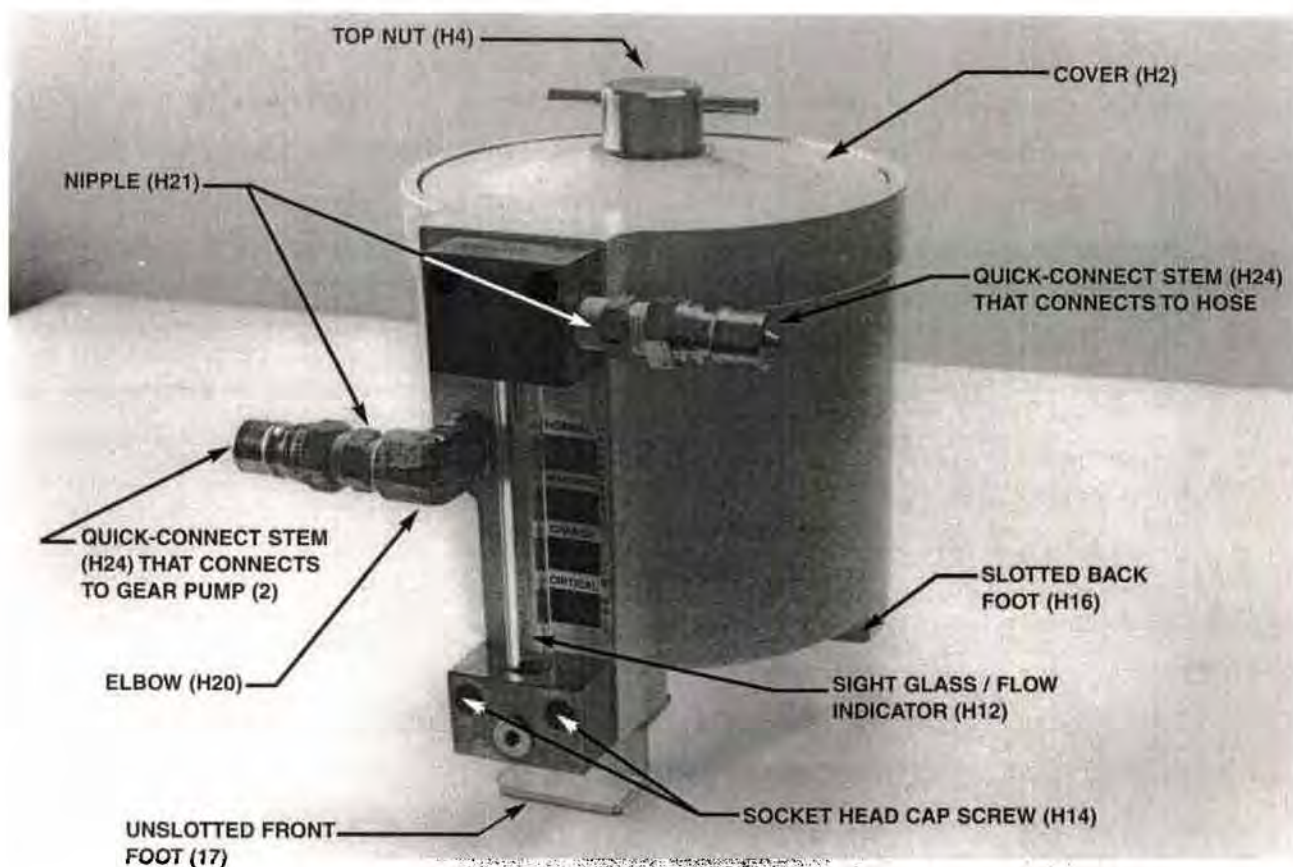

Figure 7-2 - Filter Housing Assembly

6. CAUTION: Don't allow the filter housing to sit for more than three days with contaminated oil or it may begin to corrode.

Proceed as follows to install a new filtering element into the used filter housing which you removed in Step 4 (see Figure 7-2).

- a. If your 0F-1000 is in a "clean room", take the used filter housing out of the clean room to change the filtering element.
- b. Unscrew the top nut (H4) and carefully remove the cover (H2) from the filter housing.



Section 7.2, Step 6 continued

- c. Lift the filtering element from the filter housing; oil will drain from the element as it is being removed.
- d. Tilt the filter housing to pour the remaining oil into a suitable container.
- e. If necessary, rinse or clean the filter housing with a suitable solvent before installing a new filtering element.
- f. Insert a new filtering element (see Section 3.3) into the filter housing. If the element has a wire handle, the handle should face up.
- g. Pour the correct vacuum oil into the center and outside of the filtering element until the oil level is just below the machined step in the filter housing (see Figure 9-3).
- h. Replace the used cover O-ring with the new O-ring (H5) that came with the filtering element. Be sure to coat the new O-ring with the proper oil before installing it; the cover will be difficult to remove if the O-ring hasn't been coated with oil.

Section 7.2, Step 6 continued

- i. **IMPORTANT:** Failure to seat the cover onto the filtering element could result in oil bypassing the element. An improperly installed cover could also result in an oil leak.

Fit the cover onto the top of the filter housing and begin tightening the top nut. The cover tilts slightly as it passes the lead-in chamfer of the housing. Straighten the cover and then continue tightening the nut. It may be necessary to straighten the cover several times before it is seated on the gasket on top of the filtering element. Tighten the cover hand-tight (see Figure 9-3); don't use a wrench or channel lock pliers to tighten the top nut.

A properly installed cover will be approximately 1/16 to 3/16 inch below the top rim of the filter housing. If the cover is less than 1/16 inch below the rim of the housing, it means that the filtering element isn't installed properly.

- j. Mark the installation date onto the label that came with the filtering element and attach the label to the filter-housing cover.
- k. Refer to Steps 5a through 5f when reinstalling the filter housing onto the OF-1000. Refer to Section 5 to restart the system and adjust the oil level.



7.3 CHANGING THE OIL

WARNING:

See the warning at the beginning of Section 7 before proceeding.

NOTE: Perfluoropolyether oil (PFPE) is used in OF-1000s that are prepared for extreme-corrosive service. Because of its inertness and thermal stability, PFPE doesn't normally need to be changed. If contaminants accumulate in the PFPE, run the pump with the inlet closed, the gas ballast valve open, a clean oil filtering element, and inert gas purging on the oil casing. If the PFPE isn't contaminated with hazardous media, you can also try draining the PFPE, allowing it to sit for at least 24 hours while the heavy contaminants settle out, and then decanting the light contaminants. However, some contaminants won't separate and must be removed by a reclamation vendor. Contact Leybold for recommended reclamation vendors.

NOTE: For E & DK pump models only, drain the oil from the pump using the procedure outlined in the E & DK manual. Use the steps in this section to drain the oil from the OF-1000.

If the oil has broken down or is very dirty, change it as follows:

1. Shut down power to the vacuum pump and to the OF-1000.
2. Remove the quick-connect hose assembly totally from the oil-fill port of the vacuum pump (see Figure 4-1).

3. Hold the OF-1000 hose (18) over an empty container; the container must be large enough to hold the oil from the OF-1000 as well as the oil from the vacuum pump.
4. CAUTION: Prolonged dry running will cause the gear pump to seize.

Restart the OF-1000 and allow it to run until the flow of oil begins to slow; the OF-1000 pulls the oil from the vacuum pump and empties itself.
5. Discard the used oil in accordance with safety and environmental regulations.
6. Change the filter element using the steps in Section 7.2.
7. Recharge the vacuum pump with the correct vacuum oil.
8. Reconnect the hose (18) to the vacuum pump and do the steps in Section 5 to restart the system and adjust the oil level.

7.4 CHECKING THE OIL LEVEL

WARNING:

See the warning at the beginning of Section 7 before proceeding.

Occasionally check the oil level by looking through the vacuum pump's oil-sight glass. If the level is in the lower portion of the vacuum-pump's oil sight glass while the pump is running, add oil.

Proceed as follows to add oil:

1. Remove the oil-fill plug from the top of the vacuum pump.
2. Pour the correct vacuum oil into the vacuum pump's oil-fill port until the oil level is in the middle of the pump's oil sight glass while the vacuum pump and the OF-1000 are running.
3. Reinstall the oil-fill plug into its port in the top of the vacuum pump.



SECTION 8

TROUBLESHOOTING

WARNINGS:

Hazardous gases	If the vacuum pump and/or OF-1000 has been used on corrosive, toxic, hazardous, or volatile gases, take proper safety precautions to protect personnel a) before removing the plugscrews or inlet and exhaust lines from the vacuum pump, b) before removing the OF-1000 quick-connects, and c) before removing the cover from the OF-1000 filter housing. Proper precautions could include inert gas purging before and after you drain the oil to sweep hazardous gas from the vacuum pump or optional inlet and exhaust filters; gloves or protective clothing to avoid skin contact with toxic or highly corrosive substances; specially ventilated work areas; fume hoods; safety masks; breathing apparatus; etc.
Oil leak	Process gas is often entrained in the vacuum oil. If the process gas is hazardous, you must take special safety precautions when handling the oil (see Section 7). If an oil leak develops, repair it immediately to prevent the contaminated oil from leaking from the vacuum pump or oil filtering system.
Glass sight glass	Use care when working near the sight glass. If you break this glass, oil will squirt out. If the vacuum pump is exposed to hazardous gas, the oil could also be hazardous.
Installing new hoses	If you must install new hoses, be sure to use teflon hoses with stainless steel braid and a conductive core (see Item 18 in Section 9-2). The current generated by the oil flow may arc and cause oil leaks in the standard hoses or fittings. The conductive core prevents this arcing.
Factory repair	Before sending any equipment to our factory or to one of our service centers, notify us of any toxic or other harmful products that may be in the pump, its oil, or its filters.

Table 8-1 contains instructions for troubleshooting the OF-1000 if a malfunction occurs. To use the table, first observe the symptom, then locate the trouble area, and perform the recommended corrective action. The repair steps column refers to Sections or Steps in this manual that are helpful in making the repair.

CONTENTS OF TROUBLESHOOTING CHART

Symptom	Page
1. Pump oil is leaking from the OF-1000	36
2. Abnormal running noise	36
3. The OF-1000 starts but the pressure gauge reads 0 even though the oil is cold	37
4. The oil pressure on the gauge doesn't drop after the oil is warm	38
5. The quick-connects won't snap together	39
6. Oil in the OF-1000 sight glass/flow indicator is dirty or dark even though the gauge reading is less than 50 psi	39
7. Oil level in the vacuum pump drops after startup . .	39
8. OF-1000 won't start	40
9. Oil isn't circulating sufficiently through the OF-1000	40
10. The ultimate pressure of the vacuum pump is deteriorating	40
11. Gas bubbles are visible in the oil through the OF-1000 sight glass	40

TABLE 8-1 - TROUBLESHOOTING CHART

Symptoms	Trouble Area	Probable Cause	Recommended Corrective Action	Repair Steps+
1. Pump fluid is leaking from the OF-1000*.	a. Filter housing(16)	Cover is not seated properly on the filtering element.	Seat cover on filtering element.	Sec. 4, Step 1d.
		Cover is not tightened enough.	Evenly tighten the top nut.	Sec. 4, Step 1d.
		Cover O-ring is damaged.	Replace cover O-ring (H5).	
		Filtering element is not seated properly.	Install filtering element properly.	Sec. 4, Step 1b.
	b. Gear pump (2).	Seals are worn.	Install new mechanical seal in gear pump (2).	Appendix B
c. Fittings	Fittings are not sealed properly.	Tighten fittings. If tightening does not solve the problem, replace the fitting that is leaking.		
d. Hoses (18)	Puncture or other damage.	Install new hoses.	Sec. 4	
2. Abnormal running noise.	a. Gear pump (2)**.	Dirt buildup in the gear pump (2).	Disassemble and clean the gear pump (2). Use new gasket set and mechanical seal.	Appendix B & Table 9-1
	b. Filter Housing(16)	Vibration	Tighten thumbscrews (17) securing the housing (16) to the pan (1); tighten nuts securing motor in place; tighten screws securing the handles.	
	c. Motor	Motor bearing malfunctioning.	Repair or replace motor.	

* It is normal for a few drops of pump fluid to drip out of the quick-connects just after they are disconnected.

** It is normal if a small amount of air trapped in the OF-1000 makes some noise.

+ This column contains Sections and/or Steps in this manual that are helpful in making the repair.

TABLE 8-1 - TROUBLESHOOTING CHART continued

Symptoms	Trouble Area	Probable Cause	Recommended Corrective Action	Repair Steps+
3. The OF-1000 starts but the pressure gauge reads 0 even though the oil is cold*.	a. OF-1000	Air is trapped in the OF-1000.	Allow the OF-1000 to run for 15 to 30 minutes so that the oil has time to displace the air.	Sec. 5, Step 4
		OF-1000 doesn't contain oil.	Add vacuum oil to the vacuum pump until the oil level in the vacuum pump is stabilized.	Sec. 5, Step 4
	b. Filtering Element	No filtering element in the filter housing. Filtering element isn't installed correctly.	Install filtering element.	Sec. 4, Step 1
			Correctly install filtering element.	Sec. 4, Step 1
	c. OF-1000 Motor	OF-1000 motor is running backwards.	Looking toward the fan end of the OF-1000 motor, the fan should rotate counterclockwise. If it is rotating clockwise, disconnect the power and reverse two of the input leads in the motor junction box.	Sec. 4, Step 8
	d. Hose Connections	The OF-1000 connecting hoses are switched.	Ensure that the OF-1000 FILL hose is connected to the vacuum pump's oil-fill port and that the OF-1000 DRAIN hose is connected to the vacuum pump's oil-drain port.	Sec. 4, Step 7
	e. Location of the OF-1000.	OF-1000 is greater than 5 feet above vacuum pump.	Lower OF-1000 or raise vacuum pump. Prime gear pump (2).	Sec. 5
f. Vacuum Pump	Vacuum pump doesn't contain oil.	Add vacuum oil to the vacuum pump.	Sec. 5, Step 4	

* It is normal for the pressure gauge (3) to read 5 to 30 psi when the oil is warm. The pressure should read higher than 30 psi when the oil is cold.

+ This column contains Sections and/or Steps in this manual that are helpful in making the repair.

TABLE 8-1 - TROUBLESHOOTING CHART continued

Symptoms	Trouble Area	Probable Cause	Recommended Corrective Action	Repair Steps+
4. The oil pressure on the pressure gauge (3) doesn't drop after the oil is warm*.	a. Filtering Element	Element is clogged.	Install new element.	Sec. 7.2
	b. Hoses, fittings, quick-connects	Blockage in OF-1000 downstream from the gauge (3).	Locate and clear blockage.	
		Customer replaced standard quick-connects (15/20).	Use only the standard quick-connect fittings; other fittings may reduce the flow and increase the pressure.	Items 15 & 20 in Section 9-2
	c. If pressure is 60 psi* or greater - gear pump (2).	Gear pump bypass is set too high.	Ensure that the OF-1000 hose is connected to the vacuum pump's oil-drain port. Then, remove the filter housing from the pan and switch ON the gear pump. Remove the cap nut from the bottom of the gear pump (2) and adjust the setscrew until the OF-1000 pressure reads approximately 55 psi. The setscrew should extend out about 5/8 inch from the gear pump.	

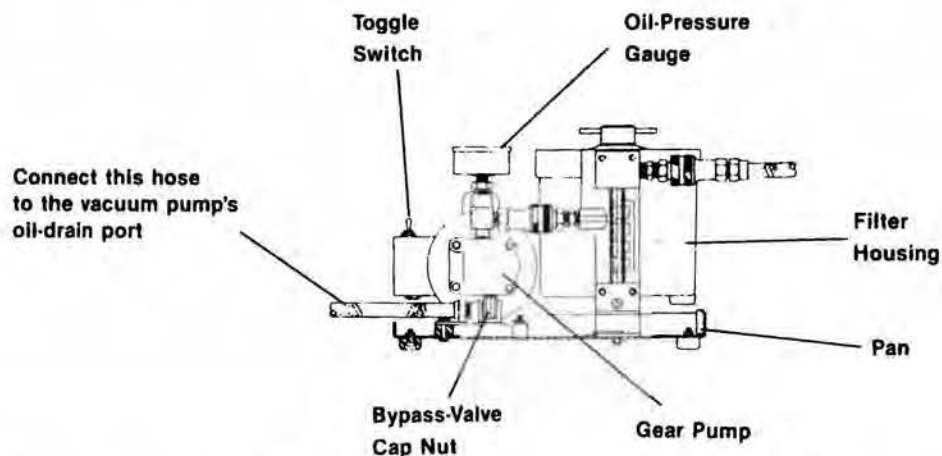

* The pressure gauge (3) should read greater than 30 psi when the oil is at room temperature and most of the air is displaced from the OF-1000.

+ This column contains Sections and /or Steps in this manual that are helpful in making the repair.

TABLE 8-1 - TROUBLESHOOTING CHART continued

Symptoms	Trouble Area	Probable Cause	Recommended Corrective Action	Repair Steps+
5. Quick-connects won't snap together.	Filter housing (16)	Quick-connect stem (20) and coupler (15) aren't perpendicular to each other.	Loosen thumbscrews (17) that secure the filter housing (16) to the pan (1) and adjust the position of the housing (16) until the quick-connects are perpendicular.	
6. Oil in the 0F-1000 sight glass (H12) is dirty or dark even though the gauge reading is less than 50 psi.	a. Filter element	Acid neutralizing capacity of element is spent but element isn't clogged.	Install new element.	Sec. 7.2
		Wrong filtering element is being used.	Contact main office for recommendations for correct filtering element.	Sec. 3.3
	b. Cover	Cover isn't seated properly on filtering element.	Ensure filtering element is installed properly	Sec. 4, Step 1d
	c. Gear pump bypass valve	The bypass valve is set too low.	Ensure that the 0F-1000 hose is connected to the vacuum pump's oil-drain port. Then, remove the filter housing from the pan and switch ON the gear pump. Remove the cap nut from the bottom of the gear pump (2) and adjust the setscrew until the 0F-1000 pressure reads approximately 55 psi. The setscrew should extend out about 5/8 inch from the gear pump.	See the sketch on the previous page.
	d. Sight glass (H12)	Sight glass is dirty.	Clean sight glass.	
7. Oil level in the vacuum pump drops after startup.	a. 0F-1000	Entrapped air was displaced by oil causing oil level to decrease.	Add the correct oil to the vacuum pump until the level stabilizes in the middle of the vacuum pump oil level glass.	Sec. 5, Step 4.
	b. Oil Leak	See Symptom 1.	See Symptom 1.	

+ This column contains Sections and/or Steps in this manual that are helpful in making the repair.

TABLE 8-1 - TROUBLESHOOTING CHART continued



Symptoms	Trouble Area	Probable Cause	Recommended Corrective Action	Repair Steps+
8. OF-1000 won't start.	a. Gear pump motor(2).	Motor isn't plugged in or switched ON.	Plug in or switch ON gear pump motor.	
		Voltage of power supply is different from rated voltage of motor.	Change wiring of motor (see instructions inside of motor junction box) or replace gear pump (2) with one that is rated for correct voltage.	Sec. 4, Step 8
		Motor bearing malfunctioning.	Replace motor bearing. Use 12 to 15 ft-lb. torque for the 4 bolts holding the gear pump to the motor.	
		Motor windings are malfunctioning.	Contact your electrician to repair the motor.	
	b. Oil	Oil is too cold or too viscous.	Heat oil. Or install the cover (H2) just far enough for the O-ring (H5) to seal; then, start the OF-1000. After the warm oil from the vacuum pump enters the OF-1000, tighten down the cover.	
c. Gear pump (2)	See Symptom 2a.	See Symptom 2a.		
9. Vacuum oil isn't circulating sufficiently through the OF-1000.	See Symptoms 2a, 3c, 4a, 4b, and 8a.	See Symptoms 2a, 3c, 4a, 4b, and 8a.	See Symptoms 2a, 3c, 4a, 4b, and 8a.	
10. The ultimate pressure of the vacuum pump is deteriorating.	a. OF-1000 filtering element and oil	Oil is contaminated.	Change filtering element in OF-1000. If oil is very dirty, change oil.	Sec. 7.1, 7.2, and 7.3
	b. Vacuum pump.	See manual that came with pump.	See manual that came with pump.	
11. Gas bubbles are visible in the oil through the OF-1000 sight glass.	a. Vacuum pump	Exhaust or process gas is entrained in oil.	No corrective action is needed. Gas entrainment is normal especially in a TRIVAC "A" dual-stage pump.	
	b. Hose or fitting on suction side of OF-1000 gear pump.	Air leak	Repair leak if air has a hazardous undesirable reaction with the process gas.	

+ This column contains Sections and/or Steps in this manual that are helpful in making the repair.

SECTION 9
PARTS LIST

NOTE: See Section 1 for the part numbers for ordering the complete OF-1000 oil filtering system.

Section 9-1 contains information for ordering spare gaskets, filtering elements, and filter housings. Section 9-2 is a complete lists of parts for the OF-1000. Section 9-3 contains the part numbers for all the parts that make up the filter housing assembly.

Use Figures 9-1 and 9-2 to help identify the part you need. The numbers called out on the figures correspond to the item numbers listed for each part in the first column of the parts list. For example, the first column on Page 45 lists "1" for the pan. On Figure 9-2, the number "1" is pointing to a drawing of the pan.

Unless noted otherwise, the part numbers marked "OF-1000C" apply to corrosive single and dual-canister models, and the part numbers marked "OF-1000" apply to standard single and dual-canister models. All other part numbers apply to all models.

CONTENTS

Title	Page
Section 9-1 - Parts List for Spare Gaskets, Filtering Elements, and Filter Housings.	43
Section 9-2 - Complete List of Parts for the OF-1000 System	45
Section 9-3 - Complete List of Parts for the Filter Housing Assembly	47

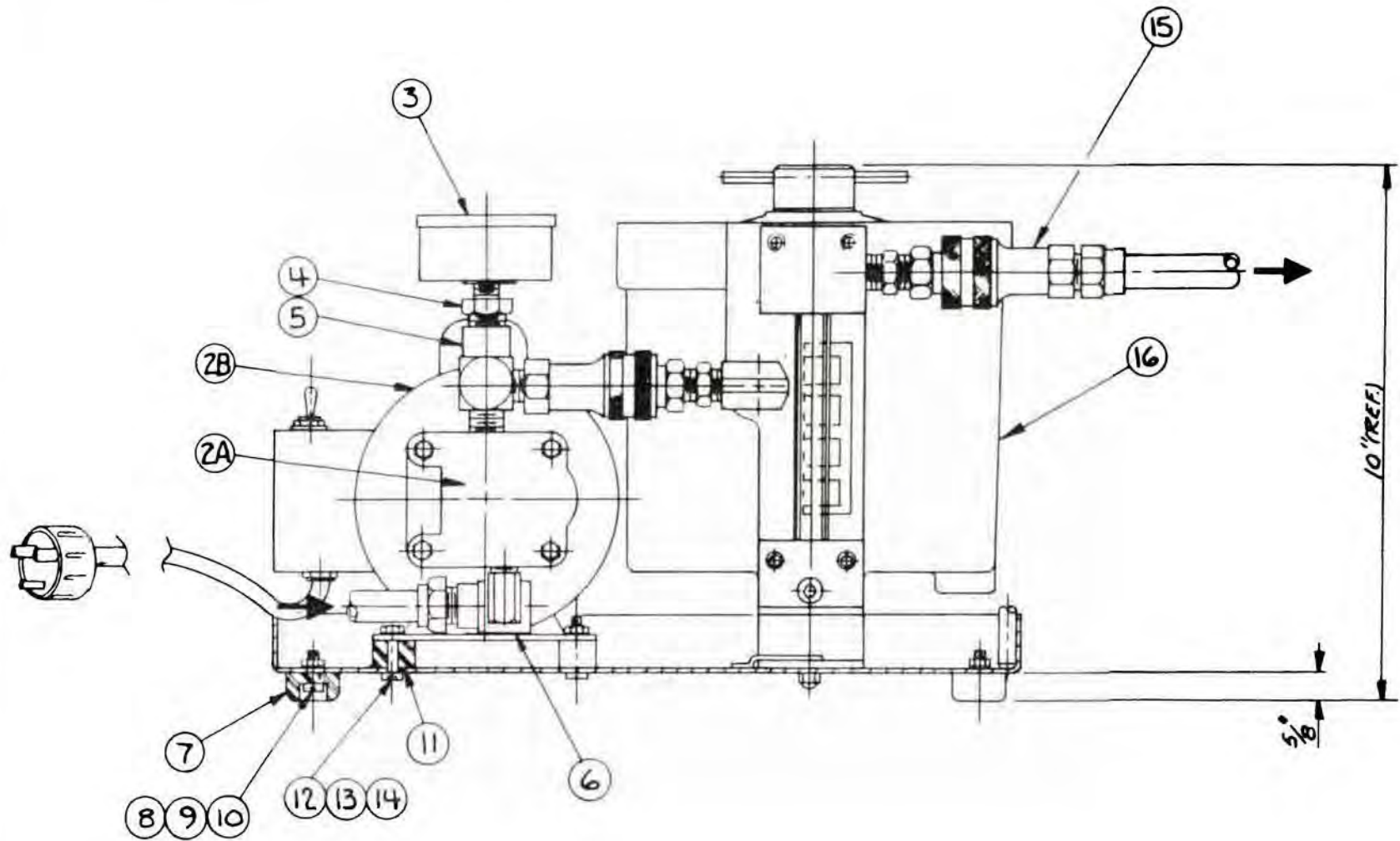

NOTE: The numbers on this figure correspond to the item no. listed for each part on page 45.
See figure 3-1 for a side view photograph of the OF-1000.

Figure 9-1 Side View of the OF-1000

SECTION 9-1

PARTS LIST FOR SPARE GASKETS, FILTERING ELEMENTS, AND FILTER HOUSINGS†

Item No. on Figs.	Quantity	Part Name	Part Number	Dimensions (inches)	Material	Remarks
H5	1	Cover O-ring	725-81-004	6.48 ID x 0.139 x Thk.	Buna-N	
N/A	1 Set	Gasket Set for Gear Pump	720-19-018		Viton	Includes relief valve seal, two O-rings, a housing gasket, and an O-ring.
N/A	1 Set	Gasket Set for Double-Head Gear Pump	720-19-019		Viton	
N/A	1	Mechanical Seal for Gear Pump	720-19-020		Viton	
		FILTERING ELEMENTS				
		Aluminum Oxide	898504		Activated Al ₂ O ₃	See Section 3.3
		Fullers Earth	898505		Fullers Earth	See Section 3.3
		Hydrophilic Particulate	898506			See Section 3.3
			898507		Fiberglass	See Section 3.3
21	2	Flat Gasket for Adapters (22)	239-55-165	22mm x 1.5 mm	Viton	This gasket seals the vane pump oil-fill and oil-drain ports
16		Standard OF-1000 Spare Filter Housing assembly*.	898555	8-1/16x9-13/16 See Figure 7-2.	Aluminum	Includes two quick-connect stems (20) and the cover and cover O-ring (H5). These housings are also used as the outer canister for the dual-canister model.
16		OF-1000 Spare Filter Housing* prepared for perfluoropolyether.	898556		Aluminum	
16		Coated OF-1000C Spare Filter Housing* prepared for perfluoropolyether.	898566		Aluminum coated with fluorocarbon	
32		Spare Center Canister* for Standard Dual-Canister Model	898557		Aluminum	See the filter housings (16) listed above for the spare outer canister for the dual-canister models.
32		Spare Center Canister* for Dual-Canister Model prepared for perfluoropolyether.	898558		Aluminum	
32		Coated OF-1000C Spare Center Canister* for Dual-Canister Model prepared for perfluoropolyether.	898559		Aluminum coated with fluorocarbon	

*Does not include the filtering element or pump fluid.

†See Section 1 for the part numbers for ordering the complete OF-1000 oil filtering system.

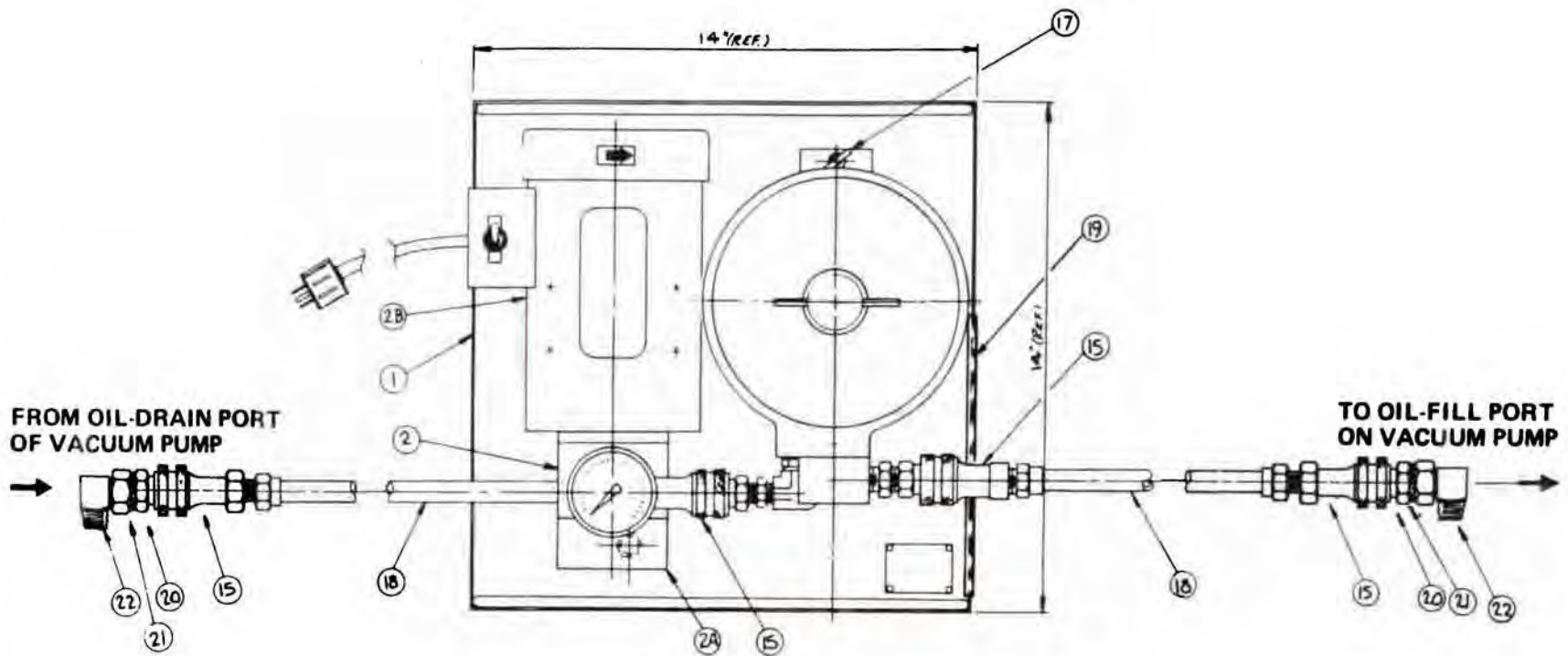

NOTE: SEE FIGURE 7-1 FOR A TOP VIEW PHOTOGRAPH OF THE OF-1000.

Figure 9-2 - Top View of the OF-1000

SECTION 9-2

COMPLETE LIST OF PARTS FOR THE OF-1000 SYSTEM

Item No. on Figs.	Quantity	Part Name	Part Number	Dimensions (inches)	Material	Remarks
1	1	Pan	720-19-013	14 x 14 x 1	Steel	For single-canister models
1	1	Pan for dual-canister model	720-19-134	14 x 23 x 1	Steel	
2	1	OF-1000 Gear pump w motor	722-92-002		Viton seals	
	1	OF-1000 Gear pump w motor (for use with PFPE oil)	722-93-006		Viton seals	Prepared for Extreme-Corrosive Service
	1	Coated OF-1000C Gear pump with motor (for use with PFPE oil)	720-19-029		Viton seals	Prepared for Extreme-Corrosive Service
2A	1	OF-1000 Gear pump	722-93-000		Viton seals	Doesn't include motor.
	1	OF-1000 Gear pump (for use with PFPE oil)	722-93-004	Doesn't include motor	Viton seals	Prepared for Extreme-Corrosive Service
	1	Coated OF-1000C Gear pump (For use with PFPE fluid)	722-93-005	Doesn't include motor	Viton seals	Prepared for Extreme-Corrosive Service
2B	1	Motor without gear pump (1/6 Hp, 1725 rpm, TEFC, Single phase.)	722-60-017	50/60 Hz, 115/208/230V, 3.6/1.8 amps		The same motor is used with the uncoated and the coated gear pump. An explosion-proof motor is also available.
2B	1	Motor without gear pump (1/6 Hp, 1725 rpm, TEFC, Three phase)	722-60-021	50/60 Hz, 230/460V, 0.74/0.37 amps.	unpainted	
3	1	Pressure gauge	722-14-000	1-1/2 diameter, 0-100 psf		Center back mount.
4	1	OF-1000 Outside Hex Bushing	725-58-200	3/8 NPT to 1/4 NPT	Steel plated	
	1	OF-1000C Hex Bushing	725-54-026	3/8 NPT to 1/4 NPT	Stainless Steel	
5	1	OF-1000 Male Street Tee	725-58-400	3/8 NPT	Steel	
	1	OF-1000C Male Street Tee	725-54-400	3/8 NPT	Stainless Steel	
6	1	OF-1000 Street Elbow	725-58-300	3/8 NPT	Steel Plated	
	1	OF-1000C Street Elbow	725-54-303	3/8 NPT	Stainless Steel	
7	4	Foot	723-07-002		Rubber	
8	4	Round Head Capscrew	96-151-1006	#10-32 x 3/4	Steel Plated	
9	4	Flat Washer	96-162-1000	SAE #10	Steel	
10	4	Hex Nut	96-159-1000	#10-32	Steel	
11	4	Foot	721-00-000		Rubber	
12	4	Hex-Head Capscrew	96-155-1110	1/4-20x1-1/4"	Steel	
13	4	Flat Washer	96-162-1100	1/4" ID	Steel	
14	4	Hex Nut	96-159-1100	1/4-20	Steel	
15	4	Quick-Connect Coupler	721-52-000	3/8 NPT	Steel w Viton	For OF-1000 models.
	4	Quick-Connect Coupler	725-54-025	3/8 NPT	Stainless Steel	For OF-1000C models
16	1	Filter Housing				See Table 9-1.
17	1	Thumbscrew	725-49-000	5/16-18x1/2" Lg.	Steel Plated	Shoulder Type S
18	48"	Hose with 3/8 NPT threaded steel ends	720-19-023	3/8 diameter.	Teflon with stainless steel braid.	
19	1	Rubber Trim	724-85-001		Rubber	
20	2	OF-1000 Quick-Connect Stem	721-52-001	3/8 FNPT	Steel w Viton	Low delta P design.
20	2	OF-1000C Quick-Connect Stem	725-54-024	3/8 NPT	Stainless Steel	
21	2	Flat Gasket	239-55-165	22 x 1.5	Viton	
22	2	Swivel Elbow Adapter	725-54-304	3/8 NPT to M16 x 1.5 mm	Stainless Steel	For use with TRIVAC pump models.
32	1	Center Canister for Dual- Canister Model				See Table 9-1

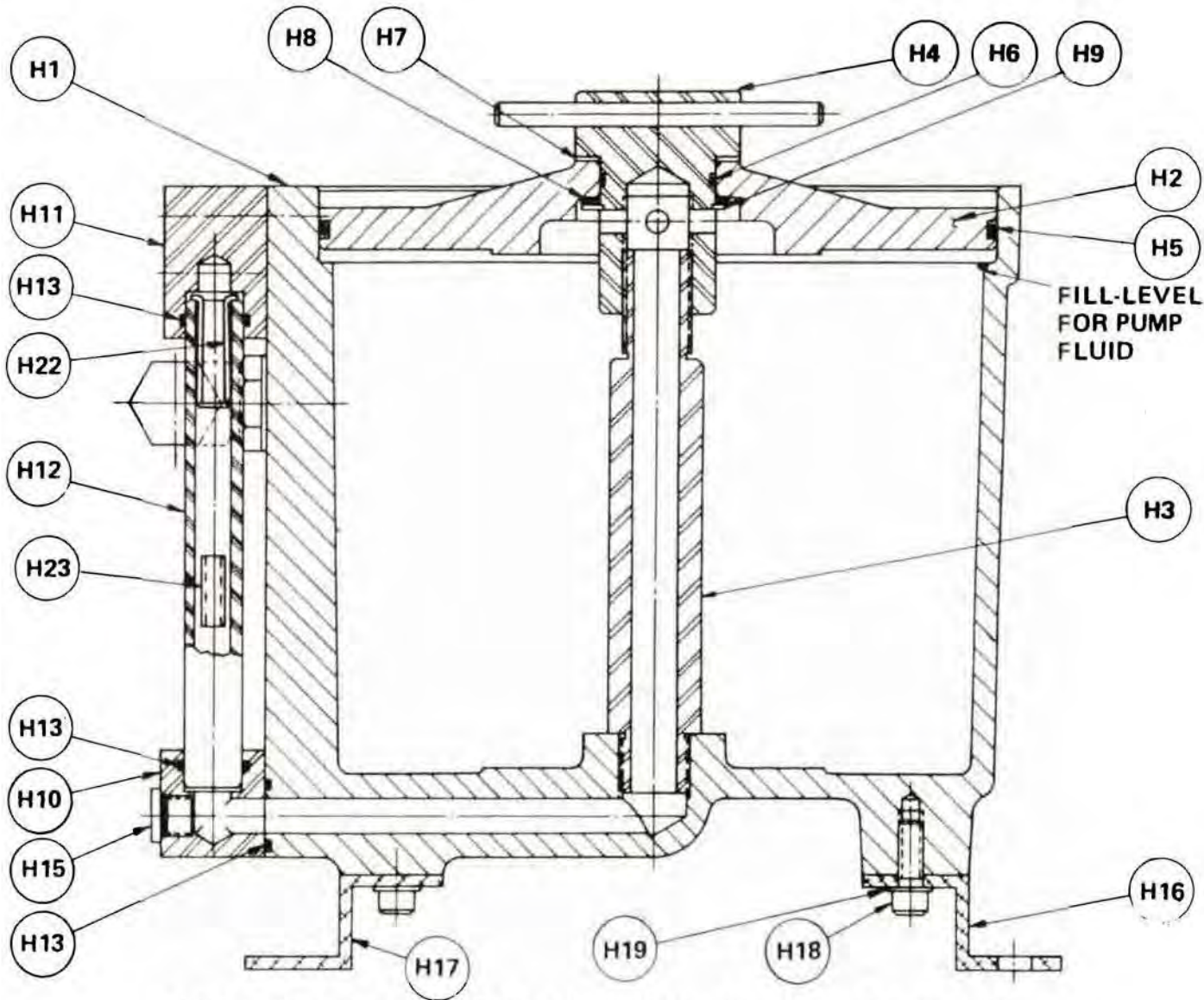

NOTE: SEE FIGURE 7-2 FOR A PHOTOGRAPH OF THE FILTER HOUSING

Figure 9-3 - Sectional View of the Filter Housing

SECTION 9-3

COMPLETE LIST OF PARTS FOR FILTER HOUSING

Item No. on Figs.	Quantity	Part Name	Part Number	Dimensions (inches)	Material	Remarks
H1	1	OF-1000 Housing	720-19-001	7-3/8 x 7-15/32	Aluminum A356	Includes a coated center tube (H3) as part of the assembly.
	1	Coated OF-1000C Housing	720-19-024	7-3/8 x 7-15/32	Aluminum A356 coated with a fluorocarbon	
H2	1	OF-1000 Cover	720-19-003	7-1/16 Diameter	Aluminum A356	
	1	Coated OF-1000C Cover	720-19-025	7-1/16 Diameter	Aluminum A356 coated with a fluorocarbon	
H3	1	OF-1000 Center Tube	720-19-009		Steel	The coated center tube is sold only as part of the coated housing assembly(H1)
H4	1	OF-1000 Top Nut	720-19-010		Plated steel	Pin (P/N 720-19-012) must be pressed into the top nut.
	1	Coated OF-1000C Top Nut	720-19-027			
	1	Grooved Pin for Top Nut	720-19-012		Plated steel	
H5	1	O-ring	725-81-004	6.484 ID x 0.139 Thk.	Buna-N	
H6	1	O-ring	725-91-003	0.862 ID x 0.103 Thk.	Viton A	
H7	1	Washer	725-49-010	1.544 OD x 1.086 ID x 0.048 Thk.	Teflon	
H8	1	Washer	725-32-004	1.561 OD x 1.064 ID x 0.032 Thk.	Steel	
H9	1	Snap Ring	720-19-035	1-1/16 diameter	Steel	
H10	1	Lower Sight Tube Housing	720-19-006			For Standard OF-1000
	1	Lower Sight Tube Housing	720-19-135		Stainless Steel	For OF-1000C models
H11	1	Upper Sight Tube Housing	720-19-005			For standard OF-1000
	1	Upper Sight Tube Housing	720-19-136		Stainless Steel	For OF-1000C
	1	Upper Sight Tube Housing	720-19-132		Stainless Steel	For center canister (32) on dual-canister models.
H12	1	Sight Glass/Flow Indicator	722-11-001		High Temp Glass	
H13	3	O-ring	725-91-002	0.61400x0.07 Thk.	Viton	
H14	4	Socket Head Cap Screw	725-02-045	1/4-20 x 1 lg.	Steel plated	See Figure 7-2.
H15	2	Hex Plug with O-ring	725-58-201	7/16-20 Straight thread.	Viton O-ring	
H15	2	Hollow Hex Plug	725-58-212	7/16-20 Straight	Stainless Steel	For OF-1000C models.
H16	1	Slotted Back Foot	720-19-007		Aluminum	
H17	1	Unslotted Front Foot	720-19-008			
H18	4	Washer	96-162-1100	1/4 ID	Steel	
H19	4	Socket Head Cap Screw	725-02-043	1/4-20 x 1/2 Lg.	Steel plated	
H20	1	OF-1000 Street Elbow	725-58-301	Straight thread	w Viton O-ring	See Figure 7-2.
H20	1	OF-1000C Elbow	725-54-301	3/8 NPT	Stainless Steel	
H21	2	Close Nipple	725-57-001	3/8 NPT	Stainless Steel	See Figure 7-2.
H22	1	Float Stop	720-19-179	5/8 washer w wire	Stainless Steel	
H23	1	Float Assembly	720-19-016	0.75" long	Aluminum	
H24	2	OF-1000 Quick-Connect Stem	721-52-001		Steel with Viton seals	See Figure 7-2. Low delta P design
H24	2	OF-1000C Quick-Connect Stem	725-54-024	3/8 NPT	Stainless steel w Viton seals	



APPENDIX A

CONVERSION INSTRUCTIONS FOR E- AND DK-PUMP MODELS

CONNECTING THE OF-1000 TO AN E- OR DK- PUMP MODIFICATION

You need two 3/8-inch NPT close nipples (P/N 725-57-001) to attach the OF-1000 hoses to the holes that you drill and tap on the E- or DK-pump.

Proceed as follows to modify an E or DK pump for using an OF-1000.

1. Drain the oil from the pump (see pump manual).
2. Remove the exhaust box from the E- or DK- pump.
3. Drill and tap holes in the E- or DK pump as follows:
 - o Mark the hole locations shown in Figure A-1.
 - o Drill the pilot holes.
 - o Drill and tap the pilot holes for the 3/8-inch NPT nipples.
 - o Clean the drill filings from the E or DK pump's exhaust valve housing.
4. Install the quick-connect stem onto the E or DK pump as follows:
 - o Remove the quick-connect stem/elbow assemblies (20/22) from the OF-1000 hoses (see Figure 9-2).
 - o Remove the elbows from the quick-connect stems.
 - o Place Teflon tape on the male threads of two 3/8-inch NPT close nipples (P/N 725-57-001) and screw one end of each nipple into a quick-connect stem (20).
 - o Screw the stem/nipple assembly into the tapped holes in the E or DK pump housing (see Figure A-1).

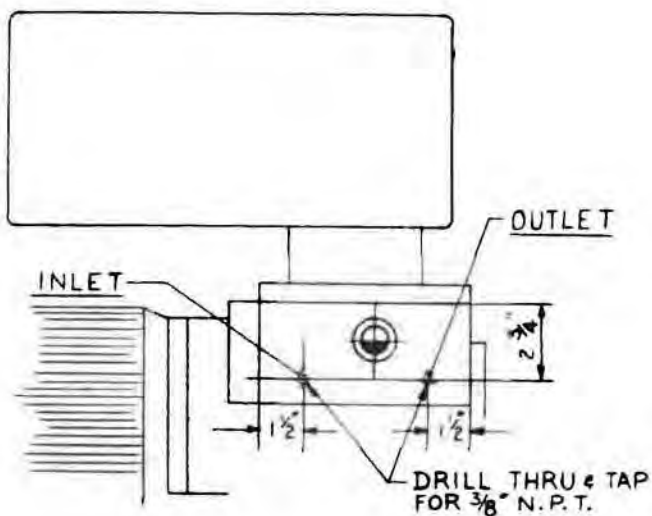

10-4.7

DK-50, DK-100, or DK-200 Pump Model

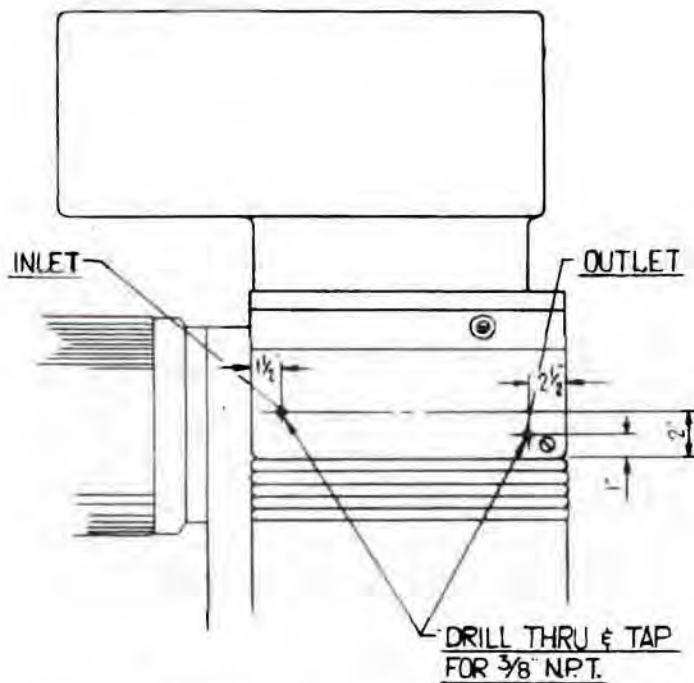

10-4.8

E-75, E-150, or E-250 Pump Model

Figure A-1 - Drilling Modification to E- or DK- Pumps
for Installing an Oil Filtering System



5. Reinstall the exhaust box onto the E or DK pump and recharge it with the correct vacuum oil (see pump manual).

6. The OF-1000 hose leading from the filter housing attaches to the hole labeled "INLET" in Figure A-1. The OF-1000 hose leading from the OF-1000's gear pump attaches to the hole labeled "OUTLET".

Proceed with normal installation and startup procedures (see Section 4 and 5).

APPENDIX B

INSTALLING A NEW MECHANICAL SEAL IN THE GEAR PUMP

WARNING: See the warning at the beginning of Section 7 before proceeding.

The mechanical seal is the most likely cause of gear pump leaks. The instructions in this appendix are for replacing the mechanical seal; it isn't necessary to completely disassemble the gear pump to replace the mechanical seal.

If you need to completely disassemble the gear pump, order the gasket set in addition to the mechanical seal kit (see Table 9-1). If you remove the bypass valve, ensure that is adjusted to extend 5/8-inch out from the gear pump on reassembly. If the needle bearings are worn, the gear pump should be scrapped.

Required Tools:

1/2-inch wrench,
1/8-inch allen wrench,
Small flat-blade screwdriver,
Rubber hammer.

Required Materials:

Mechanical seal kit (P/N 720-19-020)
Vacuum pump oil (use the same type
that will be used in the OF-1000)

Proceed as follows to remove the old mechanical seal assembly from the gear pump:

1. Switch off the OF-1000 gear pump motor.
2. Allow the pressure on the OF-1000 pressure gauge to reach 0 psi.
3. Remove the filter housing from the pan.
4. Remove the gear pump from its motor as follows:
 - a. Remove the four 1/2-inch hex bolts that secure the gear pump to the motor.
 - b. Pull the gear pump from the motor; you may have to tap it with a hammer to loosen it.
5. **CAUTION:** Use extreme care to avoid scratching the shaft or flange when prying the seals from the gear pump.

Remove the mechanical seal from the gear pump as follows (see Figure B-1):

- a. Set the gear pump on its end so that the coupling is facing up.
- b. Use an 1/8-inch allen wrench to remove the two capscrews.
- c. Remove the flange from the gear pump.
- d. Use a screwdriver to carefully pry the washer with O-ring from the flange.
- e. Use a small screwdriver to pry the mechanical seal out of the gear pump.
- f. Remove the spring and its end cap from the gear pump.

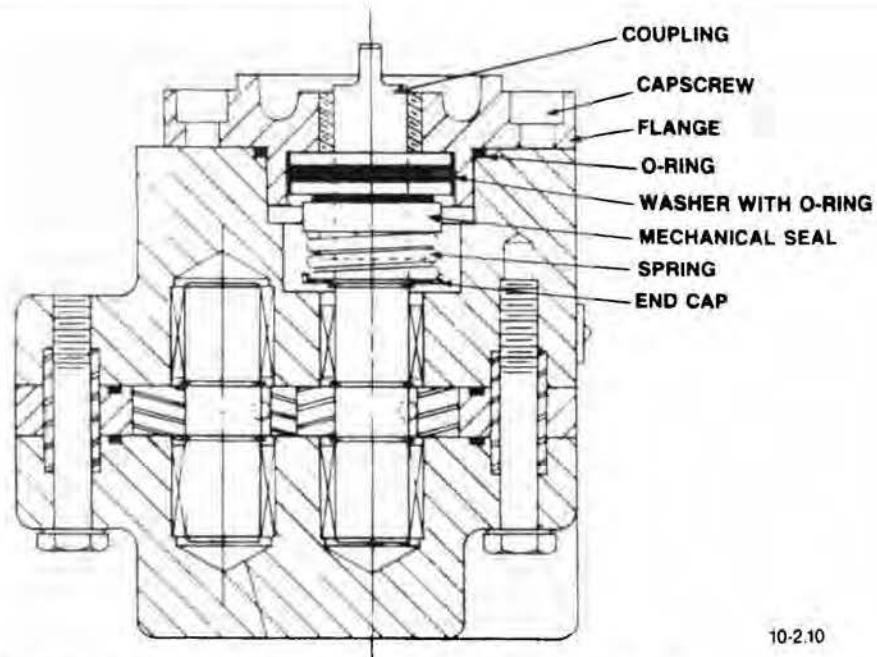

10-2.10

Figure B-1 - Cross Section of the Gear Pump

6. Install the new seals as follows (see Figure B-1):
 - a. Wet the seals and the inside of the gear pump with the same vacuum pump oil that will be used in the OF-1000.
 - b. Ensure that the sealing surface on the flange ID is free of nicks or scratches; then, press the new washer with O-ring into the flange so that the polished shiny side of the washer is facing you.
 - c. Insert the new end cap and then the new spring into into gear pump.
 - d. Ensure that the gear pump's shaft is free of burrs, nicks, or grooves that could damage the mechanical seal on installation.
 - e. The mechanical seal contains a black seal about 1/8-inch thick that fits loosely into the wider end of the metal seal housing. One side of this seal has a raised rim; ensure that the side of this seal with the raised rim is facing out and that it is free from nicks and scratches.
 - f. Wet the new mechanical seal with the correct vacuum oil and work it down the shaft; the wider end of the mechanical seal faces up.
 - g. Place the flange onto the gear pump so that the side with the O-ring faces the center of the gear pump; use the two allen head capscrews to secure the flange in place.

7. Reinstall the the gear pump onto the motor as follows:
 - a. Place the flat gasket against the motor,
 - b. Align the couplings and position the gear pump in place against the motor so that the OF-1000 pressure gauge is facing up.
 - c. Install the four hex-head screws and cross-tighten them ensuring that they are evenly torqued to 12 to 15 ft-lbs.

LEYBOLD VACUUM PRODUCTS INC.

5700 Mellon Road
Export, PA 15632-8900
U.S.A.

Telephone: 724 327-5700
Telefax: 724 733-5960

0.250-06-00

Printed in the U.S.A.