

OHTA DRY-PUMP

— Oil -less Rotary Vane Vacuum Pump and Blower —

Instruction Manual

KRX1 KRX3 KRX5 KRX6
KRX1H KRX3H KRX5H KRX6H
KRX1R KRX3R KRX5R KRX6R
KRX7A
KRA8 KRA8R
KRH8 KRH8R
KRA10 KRA10R KRH10
KRA8-DP KRA9-DP KRA10-DP
KM100

- For proper use of the OHTA Dry Pump and Blower, read this instruction manual carefully and thoroughly.

INTRODUCTION

Thank you very much for buying the OHTA Dry Pump.

The OHTA Dry Pump operates without oiling or greasing. When used as a blower, it can supply clean, compressed dry air; and when used as a vacuum pump, the exhaust does not contain any oil vapors.

As opposed to conventional oil type pumps, this dry pump can be used for a wide range of applications because no impurities are imparted to liquids or solids processed with this pump.

In addition to the precautions, description of the construction and operating procedures necessary for the operation of the pump, this instruction manual provides troubleshooting procedures and matters concerning maintenance and inspection of the pump in an easy-to-understand manner.

For normal operation of this Dry Pump, carefully read this manual and observe the instructions concerning the operation, operating procedure, maintenance and inspection.

- For proper use of the OHTA Dry Pump and Blower, read this instruction manual carefully and thoroughly.

CONTENTS

SAFETY PRECAUTIONS.....
ALWAYS OBSERVE THESE FOR SAFETY REASONS	2
PLACE WARNING AND CAUTION LABELS ON THE PUMP BODY	3
CHAPTER 1 BEFORE ACTUAL OPERATION	5
1. INSPECTION ON DELIVERY.....	5
2. PREPARATIONS FOR OPERATION	5
3. OPERATION	6
4. STORAGE.....	7
CHAPTER 2 STRUCTURE AND MAIN COMPONENTS OF PUMPS	8
1. AN EXAMPLE OF STRUCTURE AND COMPONENTS (Illustration KRX 5-SS-7501)	8
2. WHAT DIFFERENCES DO OTHER MODELS HAVE?	8
CHAPTER 3 TROUBLE SHOOTING	9
1. TROUBLE DIAGNOSIS AND REMEDY	9
CHAPTER 4 DISASSEMBLING AND ASSEMBLING PROCEDURE	11
1. PREPARATION FOR DISASSEMBLING AND REASSEMBLING	11
2. DISASSEMBLING PROCEDURE.....	11
3. REASSEMBLING PROCEDURE	12
CHAPTER 5 ROUTINE INSPECTION AND SERVICE.....	14
1. CLEANING OF FILTER	14
2. CLEANING OF VACUUM CONTROLLER AND PRESSURE CONTROLLER	14
3. INSPECTION OF PIPING SYSTEM	14
4. INSPECTION OF PUMP.....	15
5. INSPECTION OF POWER TRANSMISSION SYSTEM	15
6. TIMING TO REPLACE VANES	16

SAFETY PRECAUTIONS

Before using this product, please read the section entitled "Always observe these for safety reasons" and use the product correctly.

The precautions noted here are intended to ensure that the product is used safely and correctly, in order to prevent injury to you and others, and to prevent damage to property.

The following symbols are used in this manual:

 DANGER  WARNING  CAUTION



Indicates an imminently hazardous situation which, if not avoided, will result in death or serious injury.



Indicates a potentially hazardous situation which, if not avoided, could result in death or serious injury.



Indicates a potentially hazardous situation which, if not avoided, may result in minor or moderate injury.

Items marked with the  CAUTION symbol could also cause severe consequences, depending on the circumstances. Any item which is marked with any of these symbols is extremely important and should always be observed.

- After reading the instruction manual, make sure it is kept where it is easily accessible by anyone handling the equipment.
- If this product is given or lent to anyone else, make sure that this instruction manual is affixed to a conspicuous location on the product main unit, so that the new owner will be sure to notice it and operate the equipment safely.

About Graphic Symbols



The triangular symbol alerts the user to items involving danger, warning, or caution. The graphic symbol in the center indicates the specific action requiring caution (in the illustration at the left, this indicates caution concerning electric shock).



A line across the graphic symbol indicates that the action is forbidden. The graphic symbol in the center indicates the specific action that is forbidden (in the illustration at the left, this indicates disassembly).



A black circle symbol indicates an action that is mandatory or indicated. The graphic symbol in the center indicates the specific action that is required (in the illustration at the left, this indicates that the power supply plug should be disconnected from the outlet).



This product is intended for industrial use and should be handled extremely carefully.

Always observe these for safety reasons

Precautions regarding installation



DANGER

Indicates an imminently hazardous situation which, if not observed, will result in death or serious injury.



Keep away from combustible or explosive gases

Do not allow combustible or explosive gases to be sucked into the pump. Also, do not use combustible spray near the pump. Using the pump near combustible or explosive gases could result in an explosion or fire.



WARNING

Indicates a potentially hazardous situation which, if not observed, will result in death or serious injury.



Do not block the exhaust pipes

Do not operate the pump while the pressure controller is totally closed or the exhaust pipes are blocked. Blocking the exhaust air may increase the pressure and temperature in exhaust pipes and result in burst of the pipes and pump parts.



Do not use organic solvent for cleaning the filter element or the other parts

Do not use thinner, alcohol, benzene, gasoline, kerosene or the other organic solvent for cleaning the filter element or the other parts. Using organic solvent may result in an explosion or fire.



Do not remove the coupling cover

Do not remove the coupling cover. Coupling fan rotates at high speed and it may cut the finger or result in serious injury.



Do not damage the power supply cord

Do not cut, forcefully bend, pull on or twist the power supply cord. Do not put heavy objects on it or let it get caught or pinched. Damage to the power supply cord could result in electric shock or fire.



Keep water away from the pump and motor

Do not allow the pump and motor to come in contact with water and do not use water to clean them. In addition, do not use the pump in areas where it will come in contact with water or other liquids. Contact with water could result in electric shock or fire.



Do not touch electrical parts with wet hands

Keep wet hands away from switches, electric plugs, and all other electrical components. Touching electrical areas with wet hands may result in electric shock.



Do not modify the pump and motor

The pump and motor should never be disassembled, repaired or altered by anyone other than the service representative, dealer or a suitably qualified engineer. Incorrect operation of the equipment may result in injury and improper repairs could result in electric shock, fire, and other hazards.

Precautions regarding installation



WARNING

Indicates a potentially hazardous situation which, if not observed, will result in death or serious injury.

Frame



Always ground the pump

The pump must always be grounded using a connection screw which is equipped in the terminal box or under the frame of the electric motor. Improper grounding could result in electric shock. (Except KRX1 Single phase, 100V)



Stop operation if a problem occurs

If a problem occurs with the pump or motor, turn it off and after unplugging the power supply cable or turning off the power supply source, consult a dealer or specialist. Continuing to operate the pump incorrectly could result in electric shock or fire.



Be sure to turn it off before you begin cleaning, maintenance or inspection work.

Be sure to turn it off the pump before you begin cleaning, maintenance or inspection work, or it could result in electric shock or fire. For maintenance and inspection, please consult a dealer or specialist.



Inspect the power supply plug periodically

If a plug is connected to the power supply cord, periodically check that it is not dusty or loose and is fully inserted. Dust or loose connections can cause electric shock or fire.



Contact a dealer or specialist if the earth leakage breaker is tripped

If the earth leakage breaker is tripped, consult a dealer or a specialist. Restarting the power supply without solving the problem could result in electric shock or fire.



Install the protective equipment

Be sure to ask a specialist and install an earth leakage breaker, or it could result in electric shock or fire. Be sure to ask a specialist and install a thermal relay, or it could result in a defect or fire by an overload.



Use all two (2) support eye bolts for suspension

When using support (suspension) eye bolts, make sure all two (2) eye bolts are used and suspension angle should be 60° or more. Improper suspension could result in injury by the pump falls over or falling down.











Do not use the pump outdoors

Do not use the pump outdoors as the pump is designed to be used indoors. Using the pump outdoors could result in electric shock or fire.

Precautions regarding installation

CAUTION

Indicates a potentially hazardous situation which, if not observed, may result in injury of operator or physical damages.

-  **Do not put your hand inside the covers**
Do not put your hand inside the belt, coupling or fan covers, or it could result in severe injury such as cutting of your hands or fingers.
-  **Do not operate the electric motor over the rated power source**
Do not operate the electric motor over the rated power source, or it could result in troubles.
-  **Do not place objects on the pump**
Do not put heavy objects or containers filled with water on the pump or motor. Injuries could result from objects falling off the equipment, and spilled water could cause a short circuit, rust or electric shock if the electrical insulation is damaged.
-  **Do not touch the surface of the equipment while it is hot**
Do not touch the surface of the pump, motor or pipes as it becomes very hot. Touching the surface while the equipment or pipes are hot can result in burns.
-  **Periodically inspect the earth leakage breaker**
Operation of the earth leakage breaker should be inspected periodically. Using the pump with a faulty earth leakage breaker can result in electric shock if a short circuit occurs.
-  **Install the check valves**
Check valves should be installed to protect the pump if it runs in reverse due to residual pressure when the pump stops. The pump may be damaged or injuries can result if the check valves are not installed.
-  **Disconnect the power supply if the pump is not used for a long time**
If the pump is not used for a long period of time, disconnect the power supply plug from the outlet for safety reasons. If it is not disconnected, a short circuit or electric shock can result.
-  **Grasp the power supply cord firmly by the plug to disconnect it**
When unplugging the power supply plug, grasp the plug, and not the cord. Pulling on the cord to disconnect it can snap some of the wires and resulting in heat generation or fire.

Place of Warning and Caution labels on the pump body

The following labels, selected as the most important one from the other warnings or cautions, stuck on the pump body. Read them surely before its operation. Replace them with new ones when their surfaces are hard to read due to stains or scratches. On the new labels, please contact your local pump distributor.

■ Scald

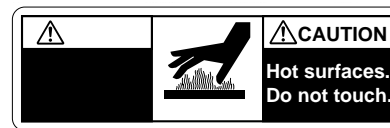

■ Electric shock

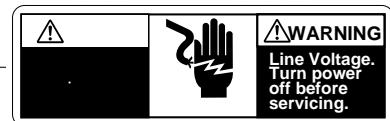

■ Injury

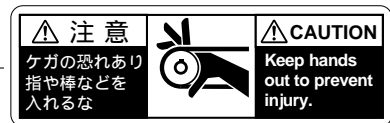

MODEL:KRX6-SS-1501-G1

OBSERVE THE FOLLOWING

1. Ambient temperature must be under 40 °C (110 °F).

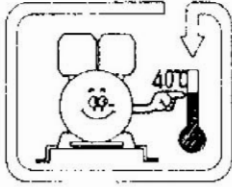

2. Keep pumps from sucking in oil, water or dust. And keep them dry from oil or water.



3. Allow space of more than 10 cm (4") between a pump and wall.

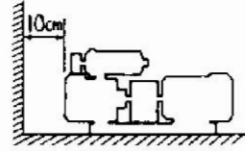

4. Avoid operation over the designated pressure below.

Model	Vacuum (V)	Blower (B)	Total V+B*
KRX1, KRX3, KRX5, KRX6 KRX7A	Max 60kPa	Max 60kPa	Max 60kPa
KRX1H, KRX1R KRX3H, KRX3R	Max 75kPa	Max 70kPa	Max 75kPa
KRX5H, KRX5R KRX6H, KRX6R KRH8, KRH8R KRH10	Max 80kPa		Max 80kPa
KRA8, KRA8R KRA10, KRA10R KRA8-DP, KRA9-DP, KRA10-DP, KM100	Max 55kPa	Max 55kPa	Max 55kPa

5. Never use pumps with flammable gases. It may explode.
Never make pumps suck liquids.

6. Surely ground pumps according to the codes and regulations of your local electrical safety standards.
And install a leakage breaker on a machine.

*Note: See P. 4 for details.

CHAPTER 1 BEFORE ACTUAL OPERATION

1. INSPECTION ON DELIVERY

Check pumps to ascertain the following when they are delivered to you.

- 1) Whether any damage exists.
- 2) Whether there are any loose nuts or bolts.
- 3) Whether the shaft can be rotated smoothly by hand. (Check while keeping suction or exhaust port open.)
- 4) Whether there are all necessary parts such as gauge and controllers, etc. in the packages.
- 5) (About KRA-DP series)
Whether V belts are adequately tightened.

2. PREPARATIONS FOR OPERATION

1) Recommended Installation Site

- (1) A well ventilated place where ambient temperature is during 0°C(32°F)~40°C(104°F)
- (2) A clean place where pumps are kept clean from dirt or dust.
- (3) A place where no oil or water will fall on pumps.
- (4) A place not exposed to direct sunlight.
- (5) A place where enough surrounding space is allowed for inspection, maintenance or disassembling.

2) Installation

Pay due attention to the following points when you are installing pumps.

- (1) Install pumps on a smooth, level surface.
- (2) Rigid foundation made of concrete is desirable. If concrete is unavailable, install them securely on a steel or sturdy wooden frame.
- (3) Keep pumps from vibrating if the foundation is unstable.
- (4) Rubber feet can be used to cut vibration effectively. Purchase them locally if necessary.
- (5) Don't drag pumps on floor, but use a forklift vehicle or a suspending tool for transporting pumps.

3) Installation Direction

- (1) When pump is installed near a wall, make its fan cover side face the wall and allow a space of more than 10 cm (4") between them for sufficient ventilation.
- (2) Make belt cover side face opposite to a wall for effective cooling of exhaust air, if the pump is "with-after-cooler" type. And allow space of more than 20 cm (8") between pump and wall, if such disposition should not be available.

4) Piping

(1) Avoid direct connection with steel pipe.

- Use hose for inlet and exhaust piping. In case of direct connection with steel pipe, resonance with the piping system **may cause noise or vibration**. For exhaust piping, use heat resistant and pressure resistant (100kPa or over) hose.
- Completely remove dirt and dust inside the hose before piping.

(2) When intake air contains a big amount of dust, or if dust grains are very fine (10 μm or less), use an appropriate filter in addition to the accessory filter.

(3) Install the hose of the exhaust piping system properly in order to prevent condensed water inside the system from entering the pump, and from discharging from the piping end.

If condensed water in the piping system enters the pump, the pump inside may be locked by rust or the blades may not come out. To avoid this situation, take the following measures:

① Install the valve or drain in the exhaust piping system so that the condensation

of water occurred inside the system can drain out. Also, drain out the collected condensation of water periodically. (See Figure 1.)

- Provide valve or drain hose on the pump side in order to prevent condensed water from entering into the pump.
- In case of a long piping system, provide valve or drain hose in the halfway of the system.
- When condensed water discharges from the piping end, install a valve or drain hose at the piping end.

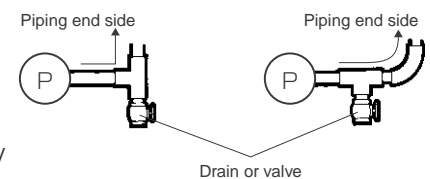

(Figure 1.)

② If the pump is not frequently used, idle the pump for 10 to 15 minutes after finishing operation.

(4) If reverse rotation is caused by residual pressure upon stopping the pump, blade damage is likely to be incurred. Please install a check valve within 50 cm from the pump's inlet port (or exhaust port) to prevent this from happening. In installing a check valve, install it levelly to the floor. Negligence may cause pulsation or abnormal noises.

(Recommended check valve: manufacturer's product name: JIS compliant KITZ bronze swing check valve)

(5) Do not apply a sealing tape when connecting pipes. Pieces of torn sealing tape may cause controller malfunction or abnormal operation sound.

(6) Do not overtighten pipes. Overtightening pipes may damage the SD case.

Standard Piping Diagram (KRX SERIES)

Top view of pump

See the attached case, at the top of the pump, from above.

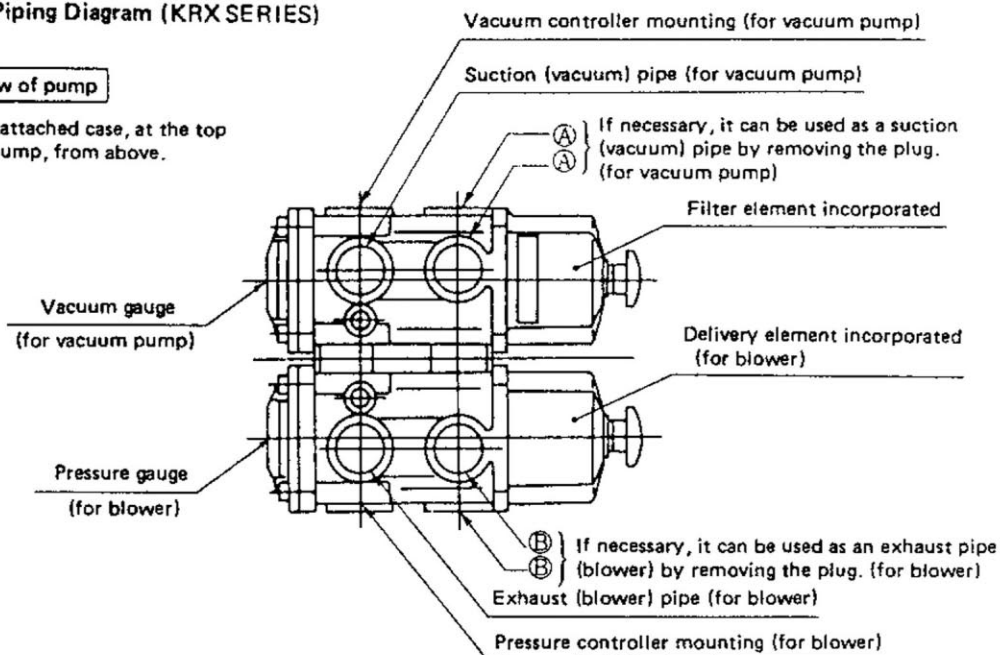

- KRA and KRH series have different cases from the ones shown above. But the principle of piping is same.

NOTES:

- (1) Controllers and gauges can be mounted on the pipes. But be sure to locate them in a place as near to the pump as possible.
- (2) It should be noted that exhaust air does not pass through the delivery element, if exhaust pipe is connected to port B.

3. OPERATION

1) Before actual operation

- (1) The arrow on a label indicates the direction of pump revolution. Confirm it when you finished installation of pumps. Turn on the switch of pump for an instant period of time for checking it. Never let pumps rotate in the reverse direction for a long period, or the vanes can break.
- (2) Prepare protective device such as thermal protector or fuse in electric circuit.
 Thermal protector capacity : 120~130% of current rating of attached motor.
 Fuse : 2 times by the current rating of the motor.
- (3) Each pump has its own maximum rotation speed as shown below. And never run the pumps at a speed over the limit.

Model		50 Hz	60 Hz
Coupling driving type	KRX 1 to 6, KRX 1H to 6H, KRX 1R to 6R	1,450 rpm	1,730 rpm
	KM 100	1,450 rpm	1,730 rpm
	KRA 8, KRA 8R, KRH 8, KRH 8R	945 rpm	1,135 rpm
Belt driving type	KRA 10, KRA 10R, KRH 10	920 rpm	1,100 rpm
	KRA8-DP	790 rpm	950 rpm
	KRA9-DP	1,100 rpm	1,300 rpm
	KRA10-DP	750 rpm	900 rpm
	KRX 7A	1,020 rpm	1,210 rpm

- (4) Direction of rotation is shown by an arrow on plate. Make sure it correctly by short time operation about 1~2 seconds at first using.

2) Starting

- (1) Follow the procedure below as the correct method of starting when piping has been completed. Turn the knob of vacuum controller and pressure regulator fully toward minus (-).
- (2) When operation of pumps is suspended for a long period of time or when pumps are reassembled after disassemblage for service, confirm if the shaft rotates lightly by hand before power switch is turned on.

3) During operation

(1) Use pumps in the designated range of pressure.

Pressure		Applicable pumps
Vacuum	Max 55 kPa	KRA series, KRA-R series, KM100
	Max 60 kPa	KRX series, KRX7A
	Max 75 kPa	KRX1H, KRX3H, KRX1R, KRX3R
	Max 80 kPa	KRX5H, KRX6H, KRX5R, KRX6R, KRH8, KRH8R, KRH10
Blower	Max 55 kPa	KRA series, KRA-R series, KM100
	Max 60 kPa	KRX series, KRX7A
	Max 70 kPa	KRX1H, to KRX6H, KRX1R to KRX6R, KRH8, KRH8R
V + B*	Max 55 kPa	KRA series, KRA-R series, KM100
	Max 60 kPa	KRX series, KRX7A
	Max 75 kPa	KRX1H, KRX3H, KRX1R, KRX3R
	Max 80 kPa	KRX5H, KRX6H, KRX5R, KRX6H, KRH8, KRH8R

(2) Pump becomes fairly hot when operated for a long period of time, but this is not abnormal.

* See foot of this page.

4) Stopping

Confirm if pumps do not rotate in the reverse direction when switch is turned off. And investigate a check valve if they rotate abnormally.

4. Adjustment of vacuum level and exhaust pressure

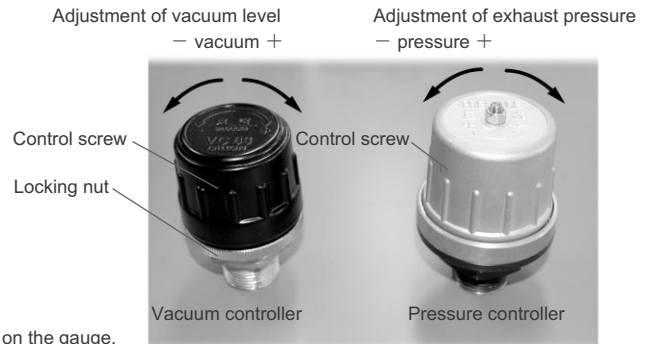

1) Adjustment of vacuum level (Vacuum controller)

- (1) Turn the locking nut clockwise to unlock the control screw.
- (2) Turn the control screw until the desired vacuum level is obtained on the gauge.
- (3) Turn the locking nut counterclockwise to lock the control screw.

2) Adjustment of exhaust pressure (Pressure controller)

- (1) Turn the control screw until the desired exhaust pressure is obtained on the gauge.

5. STORAGE

Store pumps carefully to protect them from rusting, if it will be an extended period of time before they are actually operated.

- (1) Store pumps indoors and put a suitable cover over them.
- (2) Select a place where water, oil, etc. will not fall on them.
- (3) Store them in a dry and clean place.
- (4) Keep them in a well ventilated place, where ambient temperature is below 40 °C (104 °F).
- (5) Mind especially to avoid keeping them in a place with very high temperature, chlorine gas, sulfuric acid gas or other corrosive gases.

* How to calculate total of V and B (vacuum and blower pressures)

- (1) Total pressure of V (vacuum) and B (blower)
Total pressure of V and B must be under the pressure for normal use of a pump, when it is used as a vacuum pump and a blower simultaneously.

$$V + B \leq \text{Pressure for normal use}$$

- (2) In case of KRX series with a pressure of 60 kPa for normal use of 60 kPa

Vacuum	Blower
0 kPa	60 kPa
10 "	50 "
20 "	40 "
30 "	30 "
40 "	20 "
50 "	10 "
60 "	0 "

CHAPTER 2 STRUCTURE AND MAIN COMPONENTS OF PUMPS

1. AN EXAMPLE OF STRUCTURE AND COMPONENTS (Illustration: KRX5-SS-7501)

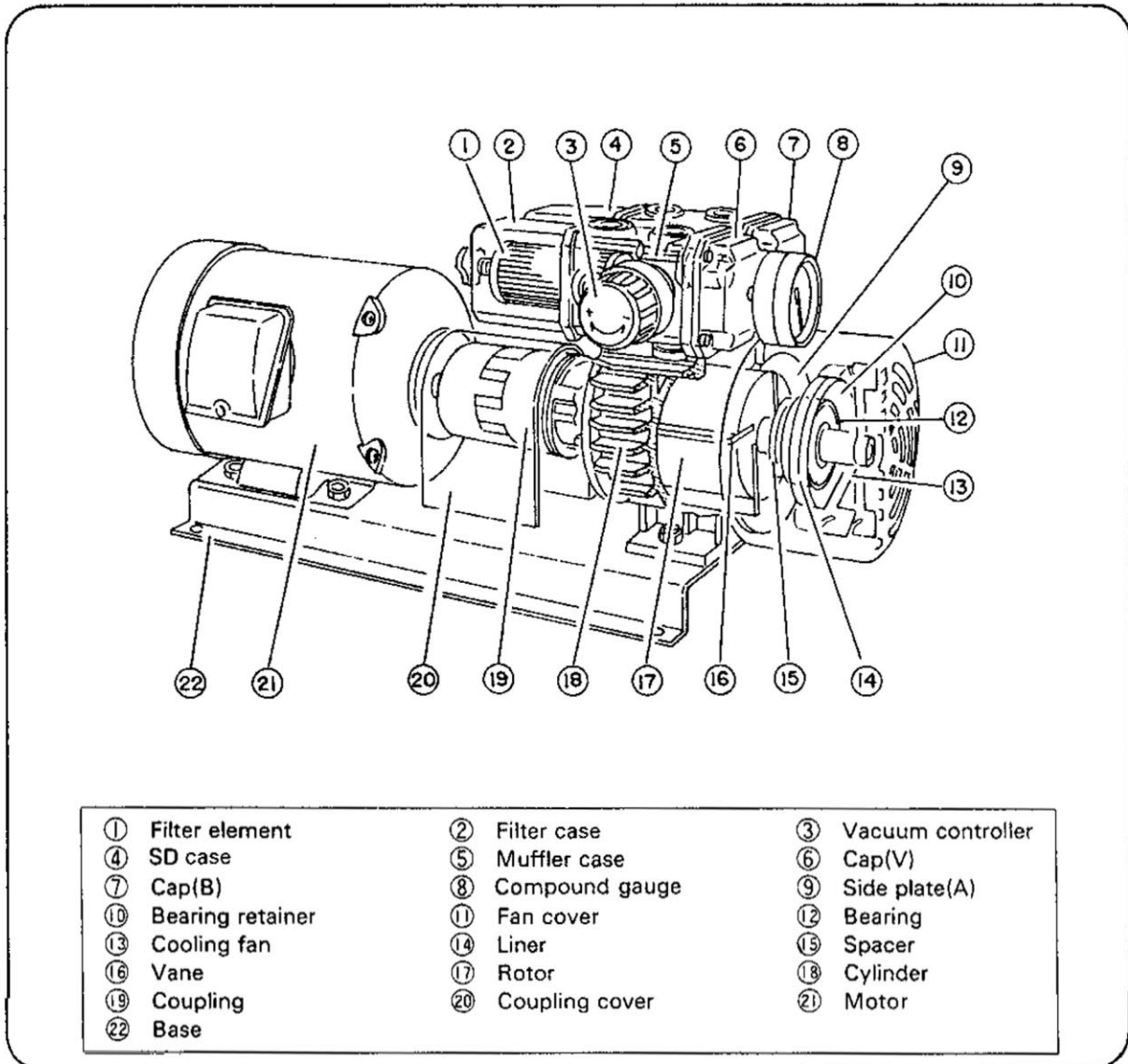

2. WHAT DIFFERENCES DO OTHER MODELS HAVE?

1) KM100-SS, KRX-SS series, KRA-SS series

Pumps of this -SS series have one pump and motor, and the power is transmitted by a coupling.

2) KRA-SP series, KRX7A-SP

Pumps of this model have one pump and motor, and a pump is driven by a belt.

3) KRA-DP

Pumps of this series have each one set of vacuum pump, blower pump and motor, and the power is transmitted by a set of belts.

CHAPTER 3 TROUBLE SHOOTING

1. TROUBLE DIAGNOSIS AND REMEDY

Eliminate cause(s) of trouble completely in order to prevent recurrence of any trouble.

1) Symptom: Pump does not gain vacuum or blower pressure

Probable cause	Treatment
Filter element is jammed with dust, and pump does not suck air.	Take out element and clean it with compressed air and Remove dust and dirt on it. And reassemble it.
Vanes do not come out due to ingress of oil in a pump.	Remove filter case and muffler case and pour a volatile solvent* in the pump. Then turn its coupling or pulley by hand. Switch the pump on when it rotates smoothly. Be careful enough not to inhale volatile solvent gas during cleaning. Open windows for full ventilation. Never use thinner, alcohol, benzene, gasoline or kerosen oil, or they will catch fire when pump is switched on. * See above for the examples.
Foreign matter in a pump interrupts projection of vanes.	Disassemble the pump to remove foreign matters.
Inside of pump is rusted due to entry of water or other liquid and smooth projection of vanes is hindered.	Disassemble the pump and remove rust in it, paying close attention not to scratch the inner surface of cylinder or rotor.
Gauge is out of order.	Replace the defective gauge.
Air is leaking due to improper connection of filter case, pipes, air tank, etc.	Securely tighten all parts.
Belt is loosened and slipping.	Adjust tension of belt. Consult Chapter 5 "Routine Inspection and Service" for correct method of adjusting tension of belt.
The mounting bolt of the coupling or pulley is loose.	Re-tighten the mounting bolt.
Revolving speed (rpm) of pump is decreased due to damage and trouble in a motor.	Repair or replace the defective motor. (Check current and voltage of electricity.)
Vane(s) is (are) broken.	Disassemble the pump and replace the defective vanes with new ones.
Vanes are worn out.	Replace the old vanes.

2) Symptom: Abnormal sound or pulsation of vacuum gauge is observed.

Probable cause	Treatment
Abnormal sound is produced due to excessive or inadequate vacuum pressure or blower pressure.	Adjust vacuum pressure or blower pressure by turning vacuum controller or pressure regulator so that it comes to normal range.
Aberration of coupling center.	Adjust the center of coupling. (Where pumps are of coupling driving type)
Eccentricity of pulley alignment causes to produce abnormal sound.	Adjust its alignment. Consult Chapter 5 "Routine Inspection and Service" for correct method of adjusting alignment.
Motor is burned out and abnormal sound is produced.	Repair or replace the motor. (Confirm current and voltage of electricity.)
Loosened bolt(s) cause(s) abnormal sound.	Retighten bolt(s).
Gauge is out of order.	Replace the gauge.
Filter element is jammed with dust and dirt, and pump does not suck air.	Consult Symptom 1).
Vanes are not projected smoothly due to sucked-in oil or other liquid.	Consult Symptom 1).
Foreign matters are sucked in pump and have broken vanes.	Disassemble the pump and take foreign matters out of it. Then replace broken vanes.
Service life of bearing has run out.	Replace the old bearing with new one.

3) Rotation of pump is stopped.

Probable cause	Treatment
Foreign matters have intruded into pump and broken vanes.	Disassemble the pump and remove foreign matters out of it. And replace the broken vanes.
Service life of vanes has run out.	Replace the old vanes.
Service life of bearing has run out or bearing is broken.	Replace the old bearing.
Rotor is in contact with housing or side plates due to excessive pressure or other causes.	Disassemble the pump and finish the contacting parts with sand paper, or ask for factory repair.
Fault in electric circuit causes to stop rotation of pump.	Check electric continuity of each part systematically.

CHAPTER 4 DISASSEMBLING AND ASSEMBLING PROCEDURE

1. PREPARATION FOR DISASSEMBLING AND REASSEMBLING

- 1) Tools of exclusive use
Tools of exclusive use are required for disassembling ORION Dry Pumps for reassembling them. They are available on order.
- 2) Genuine OHTA Dry Pumps
Use genuine ORION Dry Pump parts for replacement. Especially **BEARING** is of exclusive use of **ORION Dry Pump**. It contains special heat resistant grease. Bearing available in your market **CANNOT** be used on ORION Dry Pump.

2. DISASSEMBLING PROCEDURE

Illustrations below are based on Model KRX6, but they are common to all models of KRX, KRS 7D and KRA series.

Reassembling and adjustment require **EXPERIENCE**. Ask your nearest service factory for servicing. Keep disassembled parts in the **ORDER** of **DISASSEMBLING** for correct **REASSEMBLING**.

- 1) Take bolts of bearing retainer on both sides off, and remove paper liners and retainer. **NEVER BREAK THE LINERS**. Keep them in order so that they are placed on their original positions when reassembling.

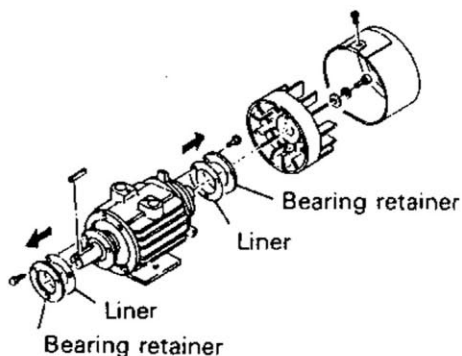

- 3) Fix side plate puller on a bearing retainer with the bolts removed in Procedure 2). Screw them into tapped holes on the bearing retainer. Be careful **NOT TO INJURE** the inner surface of side plate or of cylinder. It is **NOT RECOMMENDED** to use **OTHER TOOLS** than the **SIDE PLATE PULLER** for taking side plate off.

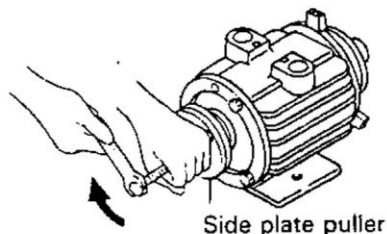

- 2) Remove fastening bolts on side plate B or side plate of motor side.

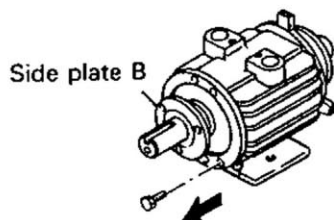

- 4) Keep bearing retainer and liner removed in Procedure 1) attached to side plate B. But **DO NOT TIGHTEN BOLTS** but **LEAVE THEM LOOSE**. (Gap between side plate B and bearing retainer must be about 1 mm.)

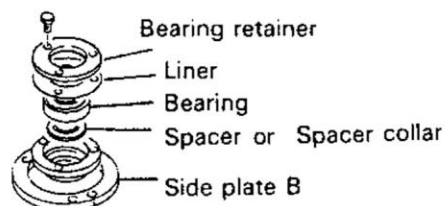

- 5) Take vanes out of pump.
Keep them orderly because they must be put back to their original position.

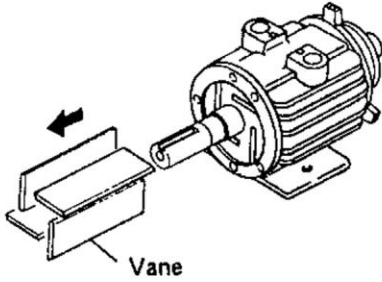

- 6) Push the rotor out from the opposite side of motor using a side plate puller.
Hold the shaft by hand or make the pump stand upright in order to protect the rotor from dropping when taking it out. **Be careful not to INJURE THE ROTOR SHAFT, CYLINDER and other parts.**

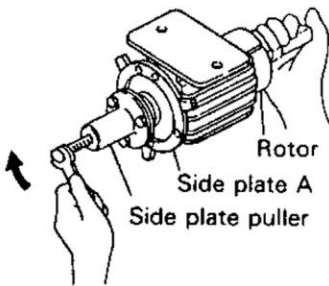

- 7) Take the clamping bolts out of the side plate A on the opposite side of motor. Then remove the side plate A, letting the knock pin loose by screwing the removed two bolts.
Clean each parts with a cloth soaked up with solvent (Exp. ABZOL™ JG)
Be careful not to LET THE BEARING COME IN CONTACT WITH THE CLEANING SOLVENT. And keep spacers, bearings and side plates in proper order so that they are TO BE PLACED AT THEIR ORIGINAL POSITIONS CORRECTLY.

3. REASSEMBLING PROCEDURE

- 1) Make the rotor stand upright, and put side plate A of opposite side of motor, bearing and other parts back to the shaft. Do not forget putting a spacer collar back to its place. But pumps with a staged shaft such as KRX5, 6 do not require a spacer collar.

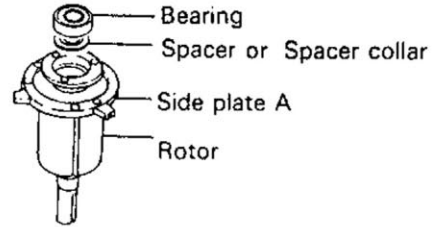

- 2) Knock bearing down with a bearing punch. Use wooden plate or the like as a pedestal in order to avoid injury on the shaft.

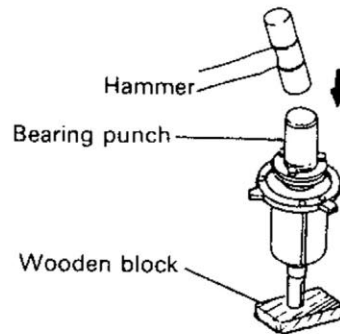

- 3) Restore the assembled rotor into cylinder. **FIX KNOCK PIN CORRECTLY, and TIGHTEN BOLTS. MIND THE DIRECTION OF ROTATION.**

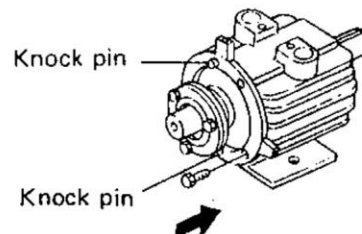

- 4) Insert vanes.
REPLACE THEM AS THEY WERE, PAYING ATTENTION TO THEIR ORIGINAL ORDER and DIRECTION.

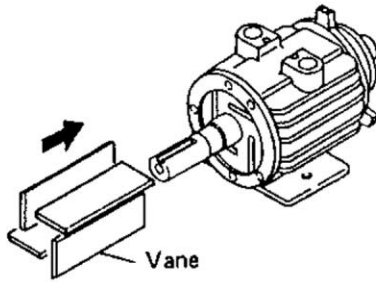

- 5) Reassemble side plate B.
 6) Fix knock pin correctly, and knock bearing down. Then tighten bolts.

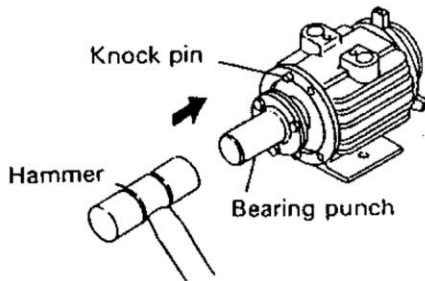

- 7) Knock BEARING, SPACERS and ROTOR with a bearing punch until all surfaces of these parts come contact tightly.

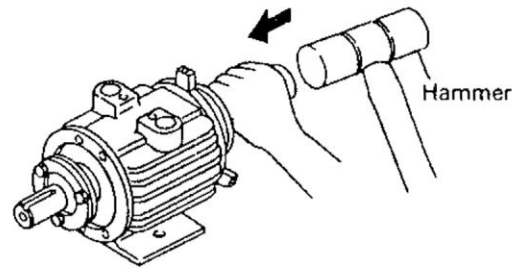

- 8) Tighten bolts of bearing retainer on both sides. The bolts are three on each side.

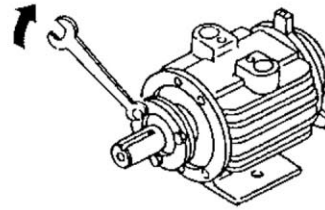

- 9) Confirm result of your servicing. Rotate the rotor shaft by hand by pushing it or pulling it toward you. And **CONFIRM IF ROTOR and SIDE PLATES DO NOT** come in contact with each other. You have done it well if they do not touch.

CHAPTER 5. ROUTINE INSPECTION AND SERVICE

Perform the following inspection and service periodically according to the extent the pump is used.

1. CLEANING OF FILTER

Clean filter when it gets dirty. 90% of would-be troubles can be prevented by always keeping filters clean. Blow dirt and dust on filters off by compressed air, when they are clogged with them. And reassemble it.

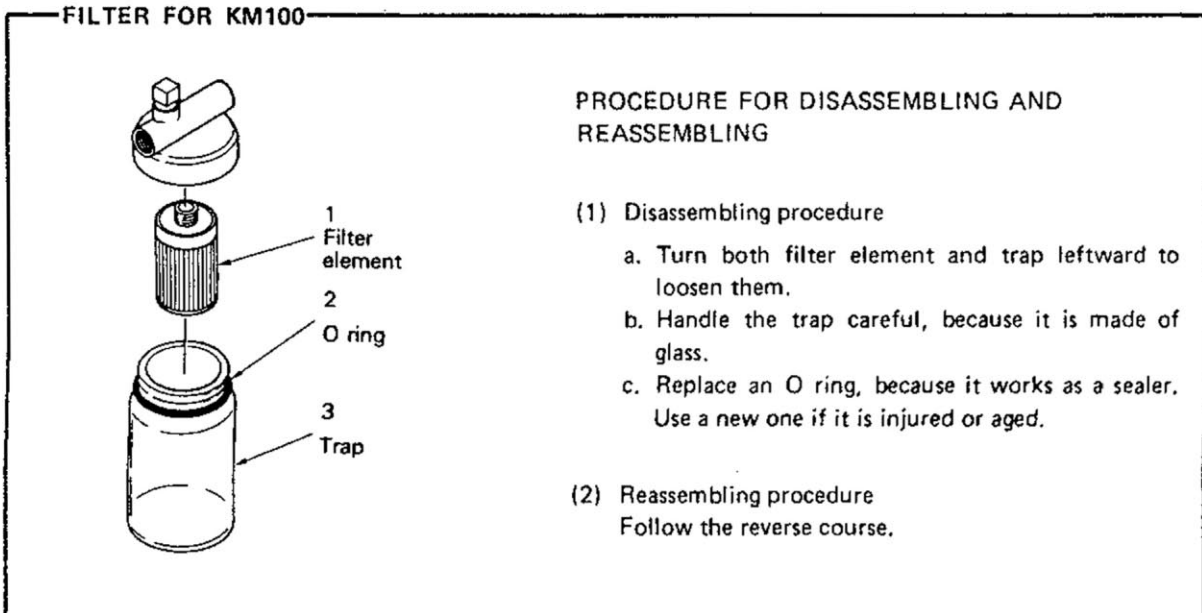
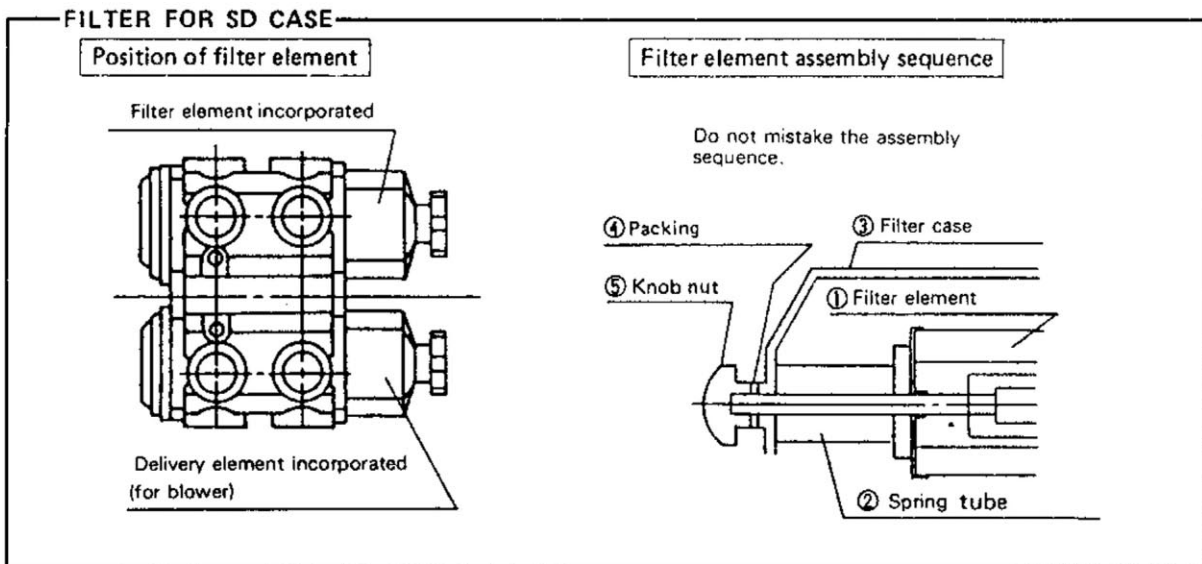

2. CLEANING OF VACUUM CONTROLLER AND PRESSURE CONTROLLER

Controllers do not work satisfactorily, when their seat's surfaces become very dirty. Dismantle them periodically to clean all parts thoroughly.

3. INSPECTION OF PIPING SYSTEM

Inspect the piping system if there is any air leakage, blocked part, loosened joint or other abnormalities. Also make sure if the cap of filter case is securely tightened.

4. INSPECTION OF PUMP

Disconnect a pipe, etc. from pump, and make the pump unload. Then rotate its shaft by hand, and confirm if it turns very freely. Contact our service shop, when it won't rotate easily.

The service life of pump is nearly ending when its performance has declined considerably or when it became to produce abnormally loud noise. Consult our service shop to have it overhauled when you observed such pump. **Special HEAT-RESISTANT BEARINGS** are employed in **ORION** pumps. Bearings commonly **AVAILABLE IN YOUR MARKET CANNOT** be used in them.

5. INSPECTION OF POWER TRANSMISSION SYSTEM

1) Pumps of coupling driving type

(1) Inspection

Examine coaxiality between pump shaft and motor shaft, space between couplings, and state of deterioration of spider (rubber or bumper).

(2) Correction of coaxiality, etc.

Insert liner(s) under the feet of pump or of motor to adjust the coaxiality between motor shaft and pump shaft, when you found its difference. And replace an old spider when you found it had been deteriorated.

Check coaxiality with a rule at two places being separate by 90° degrees (a right angle) by attaching it to the periphery of couplings.

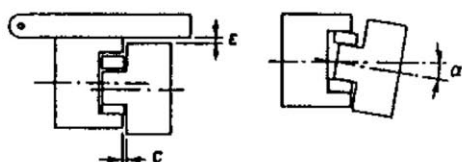

Model	KM 100 KRX 1	KRX 3 KRX 5	KRX 6	KRA 8
Model of coupling	MA 40	AL 090 CL 095	CL 100	CL 110
Eccentricity ϵ mm	0.2*	0.3*	0.3*	0.3*
Inflection angle α°	1°*	1°*	1°*	1°*
Space C mm	----	1.0	1.2	1.5

* "or under"

2) Pumps of belt driving type

Replace belts when they are worn out. And check belts for proper tension and pulleys for correct alignment. Adjust tension or alignment if necessary.

(1) Procedure to inspect tension of belts

- a. Adjust tension of belts so that the load on them becomes to be W when the sag of belt measured at the center of span between pump shaft and motor axle is δ , based on the table in P. 13.

Belt tension affects badly the life of belt and the life of bearings, when it is not appropriate.

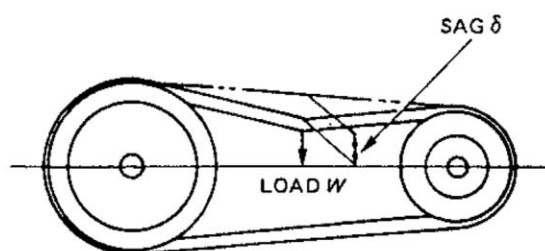

Model	Pump	Sag δ (mm)	Load W (kg/belt)
KRA10-SP	—	4.8	1.58 to 2.38
KRA8-DP	Vacuum pump	6.0	0.68 to 1.02
	Blower	6.0	0.68 to 1.02
KRA9-DP	Vacuum pump	5.4	0.68 to 1.02
	Blower	6.5	0.68 to 1.02
KRA10-DP	Vacuum pump	5.2	1.58 to 2.38
	Blower	6.9	1.58 to 2.38

- b. When you are to put on a new belt or to replace a defective belt,

- ① Reduce the distance between the shafts before you put a new belt on,
- ② And give correct tension to belt when a new one has been put on.

- c. Where pump has a set of multiple belts and one of them must be replaced, do all belts together. If new and old belts are used simultaneously, their length or elongation will be dissimilar, which will shorten their service life.

(2) Check on pulley alignment

The alignment of pulleys shortens the service life time of belt. Limit the range A of mis-alignment shown in the following figure to less than 0.15mm.

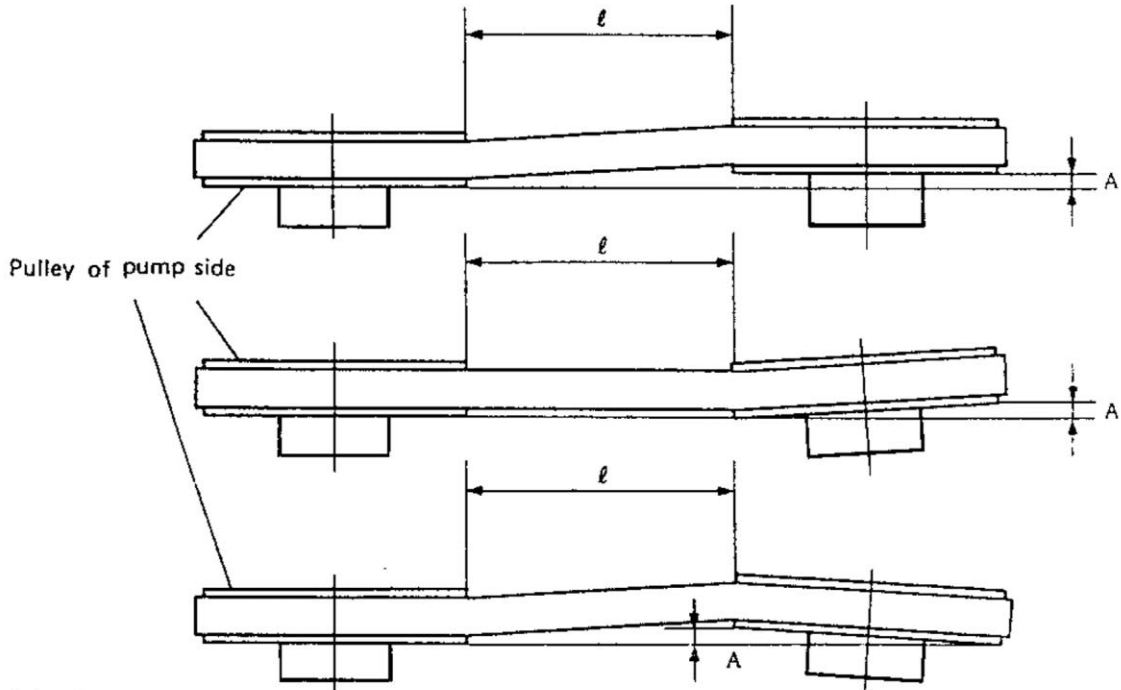

(3) How to store belts

- Do not store belts in a folded or stacked state. Avoid storing them under tension for a long period of time.
- Store belts at normal temperature and avoid direct sunshine on them.
- Do not hang them on a rack or on a wall. Do not put them directly on a floor.
- Do not let belts to become oil stained.

6. TIMING TO REPLACE VANES

Vaness of Dry Pump are consumed parts. So consult the table below for correct timing to replace and do so periodically. "Replacing timing" is only a guideline, because degree of wearing-out changes according to conditions of operation such as environment, speed of revolution, pressure, etc. Naturally it is required to replace vanes at earlier timing when pumps are used under severe conditions.

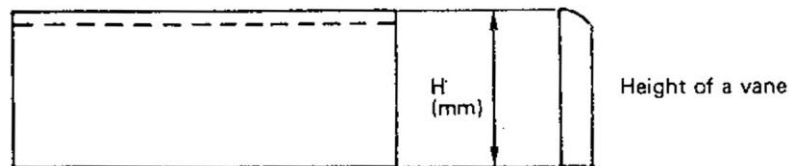

Model	Optimum replacing timing		Height of new vane (mm)
	R.H. (mm)	Worn-out H (mm)	
KM 100	16.2	8.8	25
KRX 1	24.5	7.5	32
KRX 3	26.5	7.5	34
KRX 5	29.5	8.5	38
KRX 6	31.5	8.5	40
KRX 7A	37.0	19.0	56
KRA 8, 9	41.0	10.0	51
KRA 10	47.0	11.0	58

R.H.: Recommended timing to replace vanes (shown by HEIGHT)

Note: Please replace bearings as well when you replace vanes.

ORION MACHINERY CO.,LTD.

246, Kohtaka, Suzaka City, Nagano Prefecture 382-8502, Japan

Tel: (026) 245-1230 Fax: (026) 245-5424 CABLE:TECORION SUZAKA

No.6882 '07.8.28 C DG

英語 Printed in Japan
KR/M/GE (OHTA)