



OPERATING INSTRUCTIONS

EN

Original

HIPACE 300 P

Turbopump

PFEIFFER  **VACUUM**

Dear Customer,

Thank you for choosing a Pfeiffer Vacuum product. Your new turbopump is designed to support you by its performance, its perfect operation and without interfering your individual application. The name Pfeiffer Vacuum stands for high-quality vacuum technology, a comprehensive and complete range of top-quality products and first-class service. With this expertise, we have acquired a multitude of skills contributing to an efficient and secure implementation of our product.

Knowing that our product must not interfere with your actual work, we are convinced that our product offers you the solution that supports you in the effective and trouble-free execution of your individual application.

Please read these operating instructions before putting your product into operation for the first time. If you have any questions or suggestions, please feel free to contact info@pfeiffer-vacuum.de.

Further operating instructions from Pfeiffer Vacuum can be found in the [Download Center](#) on our website.

Disclaimer of liability

These operating instructions describe all models and variants of your product. Note that your product may not be equipped with all features described in this document. Pfeiffer Vacuum constantly adapts its products to the latest state of the art without prior notice. Please take into account that online operating instructions can deviate from the printed operating instructions supplied with your product.

Furthermore, Pfeiffer Vacuum assumes no responsibility or liability for damage resulting from the use of the product that contradicts its proper use or is explicitly defined as foreseeable misuse.

Copyright

This document is the intellectual property of Pfeiffer Vacuum and all contents of this document are protected by copyright. They may not be copied, altered, reproduced or published without the prior written permission of Pfeiffer Vacuum.

We reserve the right to make changes to the technical data and information in this document.

Table of contents

1	About this manual	7
1.1	Validity	7
	1.1.1 Related documents	7
	1.1.2 Product variants affected	7
1.2	Target group	7
1.3	Conventions	7
	1.3.1 Instructions in the text	7
	1.3.2 Pictographs	8
	1.3.3 Stickers on the product	8
	1.3.4 Abbreviations	9
2	Safety	10
2.1	General safety instructions	10
2.2	Safety instructions	10
2.3	Safety precautions	14
2.4	Limits of use of the product	14
2.5	Proper use	15
2.6	Foreseeable improper use	15
3	Product description	17
3.1	Function	17
	3.1.1 Cooling	17
	3.1.2 Rotor bearing	17
	3.1.3 Drive	18
3.2	Shipment	18
3.3	Identifying the product	18
	3.3.1 Product types	18
	3.3.2 Product features	18
4	Transportation and Storage	19
4.1	Transport	19
4.2	Storage	19
5	Installation	20
5.1	Preparatory work	20
5.2	Connecting the high vacuum side	20
	5.2.1 Requirements for the dimensioning of a counter flange	20
	5.2.2 Considering earthquake protection	21
	5.2.3 Using a splinter shield or protective screen	22
	5.2.4 Using the vibration compensator	22
	5.2.5 Mounting orientations	22
	5.2.6 Attaching ISO-K flange onto ISO-K	23
	5.2.7 Attaching ISO-K flange to ISO-F	23
	5.2.8 Attach ISO-F flange to ISO-F	25
	5.2.9 Fastening CF flange to CF-F	26
5.3	Connecting the fore-vacuum side	27
5.4	Cooling water connection	28
5.5	Connecting accessories	30
	5.5.1 Connecting accessories to the turbopumps	30
	5.5.2 Connecting the venting valve	31
	5.5.3 Connecting the air cooling	31
	5.5.4 Connecting sealing gas	32
	5.5.5 Installing a heating jacket	32
5.6	Connecting the electrical supply	33
	5.6.1 Earthing the pump	34
	5.6.2 Create electrical connection	34

6	Operation	36
6.1	Commissioning	36
6.2	Operating modes	37
6.2.1	Operation without operating unit	37
6.2.2	Operation via multi-function connection "remote"	37
6.2.3	Operation via connection "E74"	37
6.2.4	Operation via Pfeiffer Vacuum display and control unit	37
6.2.5	Operation via field bus	37
6.3	Switching on the turbopump	38
6.4	Operation monitoring	38
6.4.1	Operating mode display via LED	38
6.4.2	Temperature monitoring	39
6.5	Switching off and venting	39
6.5.1	Switching off	39
6.5.2	Venting	40
7	Maintenance	41
7.1	General maintenance information	41
7.2	Maintenance intervals and responsibilities	41
7.3	Replacing the operating fluid reservoir	41
7.4	Replacing the electronic drive unit	43
7.5	Confirming the rotation speed specification	44
8	Decommissioning	46
8.1	Shutting down for longer periods	46
8.2	Recommissioning	46
8.3	Disposing of the vacuum pump	47
9	Malfunctions	48
10	Service solutions from Pfeiffer Vacuum	50
11	Spare parts HiPace 300 P	52
12	Accessories	53
13	Technical data and dimensions	54
13.1	General	54
13.2	Technical data	54
13.3	Dimensions	58
	Declaration of conformity	59

List of tables

Tbl. 1:	Abbreviations used in this document.....	9
Tbl. 2:	Permissible ambient conditions.....	15
Tbl. 3:	Product designation of Pfeiffer Vacuum HiPace turbopumps.....	18
Tbl. 4:	Turbopump features.....	18
Tbl. 5:	Requirements for the dimensioning of customer-specific high vacuum connection....	21
Tbl. 6:	Reduction of the pumping speed when using a splinter shield or protective screen....	22
Tbl. 7:	Requirements on the cooling water composition.....	29
Tbl. 8:	Requirements on the cooling water connection.....	29
Tbl. 9:	Factory pre-set accessory connections on the electronic drive unit.....	30
Tbl. 10:	Tightening torque for heating jacket fastening screws.....	33
Tbl. 11:	Factory setting of the electronic drive unit when delivered.....	36
Tbl. 12:	Behavior and meaning of the LEDS of the electronic drive unit.....	39
Tbl. 13:	Factory settings for delayed venting of turbopumps.....	40
Tbl. 14:	Characteristic nominal rotation speeds of the turbopumps.....	44
Tbl. 15:	Troubleshooting turbopumps.....	49
Tbl. 16:	Overview of the spare parts available for the HiPace 300 P.....	52
Tbl. 17:	Conversion table: Pressure units.....	54
Tbl. 18:	Conversion table: Units for gas throughput.....	54
Tbl. 19:	Technical data for HiPace 300 P 24 V.....	56
Tbl. 20:	Technical data for HiPace 300 P 48 V.....	57

List of figures

Fig. 2:	Position of the labels on the product.....	9
Fig. 3:	Design 300 P (example DN 100 ISO-K and DN 100 CF-F).....	17
Fig. 4:	Example: Safety connections.....	21
Fig. 5:	Recommended alignment when using oil-sealed backing pumps.....	22
Fig. 6:	Flange connection ISO-K to ISO-F, bracket screws.....	23
Fig. 7:	Flange connection ISO-K with ISO-F, hexagon head screw and tapped hole.....	24
Fig. 8:	Flange connection ISO-K with ISO-F, stud screw and tapped hole.....	24
Fig. 9:	Flange connection ISO-K with ISO-F, stud screw and through hole.....	24
Fig. 10:	Flange connection ISO-F, hexagon head screw and tapped hole.....	25
Fig. 11:	Flange connection ISO-F, stud screw and tapped hole.....	25
Fig. 12:	Flange connection ISO-F, stud screw and through hole.....	26
Fig. 13:	Flange connection CF-F, hexagon head screw and through hole.....	26
Fig. 14:	Flange connection CF-F, stud screw and tapped hole.....	26
Fig. 15:	Flange connection CF-F, stud screw and through hole.....	27
Fig. 16:	Example of fore-vacuum connection on HiPace 300.....	28
Fig. 17:	Connecting the cooling water supply.....	29
Fig. 18:	Connecting the air cooling.....	31
Fig. 19:	Connection of the heating jacket.....	33
Fig. 20:	Example: Connecting the grounding cable.....	34
Fig. 21:	Connecting the electronic drive unit to a power supply pack.....	35
Fig. 22:	Removing the operating fluid reservoir.....	42
Fig. 23:	Installing and removing the electronic drive unit TC 400.....	44
Fig. 24:	Spare parts HiPace 300 P.....	52
Fig. 25:	HiPace 300 TC 400 DN 100 ISO-K.....	58
Fig. 26:	HiPace 300 TC 400 DN 100 ISO-F.....	58
Fig. 27:	HiPace 300 TC 400 DN 100 CF-F.....	58

1 About this manual



IMPORTANT

Read carefully before use.
Keep the manual for future consultation.

1.1 Validity

These operating instructions are for customers of Pfeiffer Vacuum. They describe the function of the designated product and provide the most important information for safe usage of the product. The descriptions comply with applicable directives. All information provided in these operating instructions refer to the current development status of the product. The documentation remains valid as long as the customer does not modify the product in any way.

1.1.1 Related documents

Document	Number
Operating instructions, Electronic drive unit TC 400. standard	PT 0203 BN
Operating instructions, Electronic drive unit TC 400 PB, profibus	PT 0244 BN
Operating instructions, Electronic drive unit TC 400 E74, according to Semi E74	PT 0302 BN
Operating instructions, Electronic drive unit TC 400 DN, DeviceNet	PT 0352 BN
Operating instructions, Electronic drive unit TC 400 EC, EtherCat	PT 0452 BN
Declaration of conformity	A component of these instructions

Current documents are available from the [Pfeiffer Vacuum Download Center](#).

1.1.2 Product variants affected

- HiPace 300 P, DN 100 ISO-K, TC 400
- HiPace 300 P, DN 100 CF-F, TC 400
- HiPace 300 P, DN 100 ISO-F, TC 400

1.2 Target group

This operating instructions are aimed at all persons performing the following activities on the product:

- transport,
- setup (installation),
- usage and operation,
- decommissioning,
- maintenance and cleaning,
- storage or disposal.

The work described in this document is only permitted to be performed by persons with the appropriate technical qualifications (expert personnel) or who have received the relevant training from Pfeiffer Vacuum.

1.3 Conventions

1.3.1 Instructions in the text

Usage instructions in the document follow a general structure that is complete in itself. The required action is indicated by an individual step or multi-part action steps.

Individual action step

A horizontal, solid triangle indicates the only step in an action.

- This is an individual action step.

Sequence of multi-part action steps

The numerical list indicates an action with multiple necessary steps.

1. Step 1
2. Step 2
3. ...

1.3.2 Pictographs

Pictographs used in the document indicate useful information.



Note



Tip

1.3.3 Stickers on the product

This section describes all the stickers on the product along with their meaning.

	<p>Rating plate</p> <p>The rating plate of the turbopump is located on the lower part of the vacuum pump.</p>
	<p>Operating instructions note</p> <p>This sticker indicates that this operating instructions must be read before performing any tasks.</p>
	<p>Protection class</p> <p>This sticker describes protection class 1 for the product. The positioning indicates the position for the ground connection.</p>
	<p>Closure seal</p> <p>The product is sealed ex-factory. Damaging or removing a closure seal results in loss of the warranty.</p>

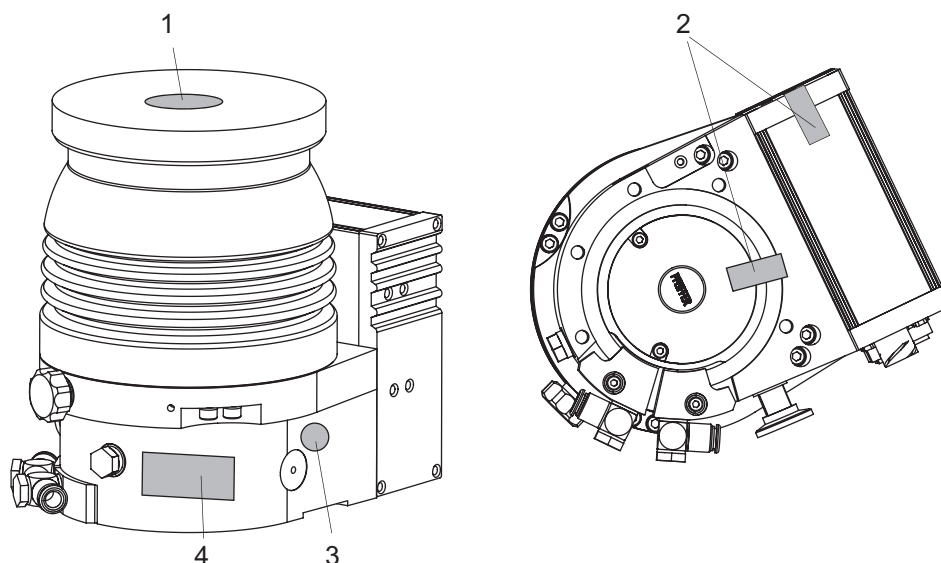

Fig. 2: Position of the labels on the product

- | | |
|-------------------------------|---------------------------------|
| 1 Operating instructions note | 3 Note for ground connection |
| 2 Closure seal | 4 Rating plate of the turbopump |

1.3.4 Abbreviations

Abbreviation	Meaning in this document
CF	Flange: Metal-sealed connector in accordance with ISO 3669
d	Diameter value (in mm)
DC	Direct current
DCU	Display Control Unit (Pfeiffer Vacuum display and control unit).
DN	Nominal diameter as size description
f	Rotation speed value of a vacuum pump (frequency, in rpm or Hz)
P	Process execution
HPU	Handheld Programming Unit. Aid for control and monitoring of pump parameters
HV	High vacuum flange, high vacuum side
ISO	Flange: Connector in accordance with ISO 1609 and ISO 2861
LED	Illuminating diode
PE	Earthed conductor (protective earth)
[P:xxx]	Electronic drive unit control parameters. Printed in bold as three-digit number in square brackets. Frequently displayed in conjunction with a short description. Example: [P:312] software version
remote	26-pole D-Sub connecting socket on the turbopump electronic drive unit
S1	S1 switch on power supply pack
WAF	width across flats
T	Temperature (in °C)
TC	Turbopump electronic drive unit (turbo controller)
TPS	Voltage supply (turbo power supply)
VV	Fore-vacuum flange, fore-vacuum connection

Tbl. 1: Abbreviations used in this document

2 Safety

2.1 General safety instructions

This document includes the following four risk levels and one information level.

⚠ DANGER	
<p>Imminent danger Indicates a hazardous situation which, if not avoided, will result in death or serious injury.</p> <ul style="list-style-type: none"> ▶ Instructions on avoiding the hazardous situation 	
⚠ WARNING	
<p>Possibly imminent danger Indicates a hazardous situation which, if not avoided, could result in death or serious injury.</p> <ul style="list-style-type: none"> ▶ Instructions on avoiding the hazardous situation 	
⚠ CAUTION	
<p>Possibly imminent danger Indicates a hazardous situation which, if not avoided, could result in minor or moderate injury.</p> <ul style="list-style-type: none"> ▶ Instructions on avoiding the hazardous situation 	
NOTICE	
<p>Danger of property damage Notice is used to address practices not related to physical injury.</p> <ul style="list-style-type: none"> ▶ Instructions on avoiding property damage 	
<div style="border: 1px solid black; padding: 5px; display: inline-block;">  </div>	Notes, tips or examples indicate important information on the product or on this document.

2.2 Safety instructions

All safety instructions in this document are based on the results of the risk assessment carried out in accordance with Machinery Directive 2006/42/EC Annex I and EN ISO 12100 Section 5. Where applicable, all life cycle phases of the product were taken into account.

Risks during transport

⚠ WARNING
<p>Danger of serious injury due to falling objects Due to falling objects there is a risk of injuries to limbs through to broken bones.</p> <ul style="list-style-type: none"> ▶ Take particular care and pay special attention when transporting products manually. ▶ Do not stack the products. ▶ Wear protective equipment, e.g. safety shoes.

Risks during installation

⚠ DANGER**Danger to life from electric shock**

Power supply packs that are not specified or are not approved will lead to severest injuries up to death.

- ▶ Make sure that the power supply pack meets the requirements for double isolation between mains input voltage and output voltage, in accordance with IEC 61010 and IEC 60950.
- ▶ Make sure that the power supply pack meets the requirements in accordance with IEC 61010 and IEC 60950.
- ▶ Where possible, use original power supply packs or only power supply packs that correspond with the applicable safety regulations.

⚠ WARNING**Risk of danger to life through missing mains disconnection device**

The vacuum pump and electronic drive unit are **not** equipped with a mains disconnection device (mains switch).

- ▶ Install a mains disconnection device according to SEMI-S2.
- ▶ Install a circuit breaker with an interruption rating of at least 10,000 A.

⚠ WARNING**Risk of injury due to incorrect installation**

Dangerous situations may arise from unsafe or incorrect installation.

- ▶ Do not carry out your own conversions or modifications on the unit.
- ▶ Ensure the integration into an Emergency Off safety circuit.

⚠ WARNING**Risk of cuts on moving, sharp-edged parts when reaching into the open high vacuum flange**

With the high vacuum flange open, access to sharp-edged parts is possible. A manual rotation of the rotor increases the danger situation. There is the risk of cuts, up to the separation of body parts (e.g. fingertips). There is a risk of hair and loose clothing being drawn in. Objects falling in destroy the turbopump during subsequent operation.

- ▶ Only remove the original protective covers immediately prior to connecting the high vacuum flange.
- ▶ Do not reach into the high vacuum connection.
- ▶ Wear protective gloves during installation.
- ▶ Do not start the turbopump with open vacuum connections.
- ▶ Always carry out the mechanical installation before electrical connection.
- ▶ Prevent access to the high vacuum connection of the turbopump from the operator side (e.g. open vacuum chamber).

⚠ WARNING**Danger of cut injuries from unexpected start up.**

The use of mating plugs of the electronic drive unit (accessories) enables the automatic run-up of the vacuum pump as soon the power is turned on. Attaching mating plugs before or during the installation leads to the movement of parts hence the risk of cut injuries by sharp-edged in the exposed high vacuum flange.

- ▶ Only connect mating plugs after the mechanical installation.
- ▶ Only switch on the vacuum pump immediately prior to operation.

⚠ WARNING

Risk of scalding from suddenly escaping hot cooling water

The turbopump water connections are open to both sides. When connecting the cooling water supply, there is a risk of scalding from suddenly escaping, hot cooling water at over pressure.

- ▶ Prior to installation, ensure that pressure is discharged from the cooling water system, and that it is cooled down.
- ▶ Wear protective equipment, e.g., safety goggles and gloves.

Risks during operation

⚠ WARNING

Risk of burns on hot surfaces when using additional equipment for heating during operation

The use of additional equipment for heating the vacuum pump or for optimizing the process generates very high temperatures on surfaces that can be touched. There is a risk of burning.

- ▶ If necessary, set up a contact guard.
- ▶ If necessary, apply the warning stickers provided for this at the danger points.
- ▶ Ensure adequate cooling down before working on the vacuum pump or in its vicinity.
- ▶ Wear protective equipment, e.g., gloves.

⚠ WARNING

Risk of serious injury in the event of vacuum pump destruction due to over pressure

Gas entry with very high over pressure results in destruction of the vacuum pump. There is a risk of serious injury due to ejected objects.

- ▶ Never exceed the permissible 1500 hPa (absolute) inlet pressure on the suction side or the venting and sealing gas connection.
- ▶ Make sure that high, process-related over pressures cannot directly enter the vacuum pump.

⚠ CAUTION

Risk of injuries due to contact with vacuum when venting

While venting the vacuum pump there is a risk of minor injuries due to the direct contact of body parts with the vacuum, e.g. hematomas.

- ▶ Do not fully unscrew the venting screw out of the housing during venting.
- ▶ Keep a distance from automatic venting device, such as venting valves.

Risks during maintenance

⚠ WARNING

Health hazard through poisoning from toxic contaminated components or devices

Toxic process media result in contamination of devices or parts of them. During maintenance work, there is a risk to health from contact with these poisonous substances. Illegal disposal of toxic substances causes environmental damage.

- ▶ Take suitable safety precautions and prevent health hazards or environmental pollution by toxic process media.
- ▶ Decontaminate affected parts before carrying out maintenance work.
- ▶ Wear protective equipment.

⚠ WARNING

Risk of burns on hot surfaces when using additional equipment for heating during operation

The use of additional equipment for heating the vacuum pump or for optimizing the process generates very high temperatures on surfaces that can be touched. There is a risk of burning.

- ▶ If necessary, set up a contact guard.
- ▶ If necessary, apply the warning stickers provided for this at the danger points.
- ▶ Ensure adequate cooling down before working on the vacuum pump or in its vicinity.
- ▶ Wear protective equipment, e.g., gloves.

⚠ WARNING**Risk of cuts on moving, sharp-edged parts when reaching into the open high vacuum connection**

Incorrect handling of the turbopump before maintenance work results in hazardous situations with risk of injury. There is a risk of cuts from accessing sharp-edged, rotating parts when removing the turbopump.

- ▶ Wait until the turbopump comes to a standstill (rotation speed $f=0$).
- ▶ Switch the turbopump off properly.
- ▶ Secure the turbopump against re-start.
- ▶ Close open connections immediately following removal, using the original protective cover.

⚠ CAUTION**Risk of injuries due to contact with vacuum when venting**

While venting the vacuum pump there is a risk of minor injuries due to the direct contact of body parts with the vacuum, e.g. hematomas.

- ▶ Do not fully unscrew the venting screw out of the housing during venting.
- ▶ Keep a distance from automatic venting device, such as venting valves.

⚠ CAUTION**Electric shock and damage to the vacuum pump and electronic drive unit due to improper disconnection of components**

Even after the mains power is switched off, the turbopump continues to deliver electrical energy during its run-down period. If the turbopump and electronic drive unit are disconnected prematurely, there is the risk of electric shock from contact with live components. There is a risk of electric body contact and, as a result, the destruction of electronic components.

- ▶ Never disconnect the turbopump and electronic drive unit from each other if power is still connected or if the rotor is running.
- ▶ Monitor the turbopump rotation via the parameters available in the electronic drive unit (e.g., [P: 398]).
- ▶ Wait until the turbopump comes to a standstill (rotation speed $f=0$).

Risks in the event of malfunctions**⚠ WARNING****Danger to life from electric shock in the event of a fault**

In the event of a fault, devices connected to the mains may be live. There is a danger to life from electric shock when making contact with live components.

- ▶ Always keep the mains connection freely accessible so you can disconnect it at any time.

⚠ WARNING**Danger to life from the turbopump breaking away in the event of a fault**

Sudden blocking of the rotor generates high destructive torques in accordance with ISO 27892. If the turbopump is **not** properly secured, it will tear off. The energy released in this way can propel the entire turbopump or shattered pieces from its interior through the surrounding area. Potentially dangerous gases may escape. There is a risk of serious injury, potentially even fatal, and significant equipment damage.

- ▶ Follow the installation instructions for this turbopump.
- ▶ Observe the requirements regarding stability and design of the counter flange.
- ▶ Use only original accessories or fixing material approved by Pfeiffer Vacuum for the installation.

⚠ WARNING

Risk of injury caused by the turbopump breaking away with the vibration compensator in the event of a malfunction

Sudden jamming of the rotor generates high destructive torques in accordance with ISO 27892. When using a vibration compensator, this will probably lead to the turbopump being sheared off in use. The energy that this would release could throw the entire turbopump or shattered pieces from its interior through the surrounding space. Potentially dangerous gases can escape. There is a risk of very serious injuries, including death, and extensive property damage.

- ▶ Take suitable safety precautions on-site for the compensation of the occurring torques.
- ▶ Before installing a vibration compensator, you must first of all contact Pfeiffer Vacuum.

⚠ WARNING

Danger to life from poisoning where toxic process media leak from damaged connections

Sudden twisting of the turbopump in the event of a fault causes fittings to accelerate. There is the risk of damaging on-site connections (e.g., fore-vacuum line) and resulting leaks. This results in leakage of process media. In processes involving toxic media, there is a risk of injury and danger to life due to poisoning.

- ▶ Keep masses connected to the turbopump as low as possible.
- ▶ Use flexible lines to connect to the turbopump where necessary.

2.3 Safety precautions



Duty to provide information on potential dangers

The product holder or user is obliged to make all operating personnel aware of dangers posed by this product.

Every person who is involved in the installation, operation or maintenance of the product must read, understand, and adhere to the safety-related parts of this document.



Infringement of conformity due to modifications to the product

The Declaration of Conformity from the manufacturer is no longer valid if the operator changes the original product or installs additional equipment.

- Following installation into a system, the operator is required to check and re-evaluate as necessary the conformity of the overall system in the context of the relevant European Directives before commissioning that system.

General safety precautions when handling the product

- ▶ Observe all applicable safety and accident prevention regulations.
- ▶ Check that all safety measures are observed at regular intervals.
- ▶ Do not expose body parts to the vacuum.
- ▶ Always ensure a secure connection to the earthed conductor (PE).
- ▶ Never disconnect plug connections during operation.
- ▶ Observe the above shutdown procedures.
- ▶ Before working on the high vacuum connection, wait until the rotor has stopped completely (rotation speed $f = 0$).
- ▶ Never put the device into operation with the high vacuum connection open.
- ▶ Keep lines and cables away from hot surfaces ($> 70^{\circ}\text{C}$).
- ▶ Never fill or operate the unit with cleaning agents or cleaning agent residues.
- ▶ Do not carry out your own conversions or modifications on the unit.
- ▶ Observe the unit protection class prior to installation or operation in other environments.

2.4 Limits of use of the product

Installation location	weatherproof (internal space)
Air pressure	750 hPa to 1060 hPa

Installation altitude	max. 5000 m
Rel. air humidity	max. 80%, at T < 31°C, up to max. 50% at T < 40°C
Protection class	III
Excess voltage category	II
Permissible protection class	IP54
Degree of contamination	2
Ambient temperature	5 °C to 30 °C with convection cooling without gas throughput 5°C to 35°C with air cooling 5°C to 40°C with water cooling
Permissible surrounding magnetic field	5.5 mT
Maximum irradiated thermal output	2.4 W
Maximum permissible rotor temperature of the turbopump	110 °C

Tbl. 2: Permissible ambient conditions



Notes on ambient conditions

The specified permissible ambient temperatures apply to operation of the turbopump at maximum permissible backing pressure or at maximum gas throughput, depending on the cooling type. The turbopump is intrinsically safe thanks to redundant temperature monitoring.

- The reduction in backing pressure or gas throughput permits operation of the turbopump at higher ambient temperatures as well.
- If the maximum permissible operating temperature of the turbopump is exceeded, the electronic drive unit first reduces the drive output and switches it off where necessary.

2.5 Proper use

- ▶ Use the turbopump only for generating vacuum.
- ▶ Use the turbopump only in combination with a suitable backing pump that can deliver up to the required maximum fore-vacuum pressure.
- ▶ Use the turbopump only in closed indoor areas.
- ▶ Use the turbopump only for the evacuation of dry and inert gases.
- ▶ Use the turbopump for the evacuation of corrosive gases only in conjunction with sealing gas.

2.6 Foreseeable improper use

Improper use of the product invalidates all warranty and liability claims. Any use that is counter to the purpose of the product, whether intentional or unintentional, is regarded as misuse.

- Transport, installation or operation of the vacuum pump in an impermissible spatial position
- Establishing the voltage supply without correct installation
- Installing the pump with unspecified mounting material
- Pumping explosive media
- Pumping corrosive media without using sealing gas
- Pumping dust without using sealing gas
- Pumping of fluids
- Operation with impermissible high gas throughput
- Operation with impermissible high fore-vacuum pressure
- Operation with excessively high irradiated heat output
- Operation in impermissible high magnetic fields
- Operation in an incorrect gas mode

- Venting with impermissible high venting rates
- Use for pressure generation
- Use in areas with ionizing radiation
- Operation in explosion-hazard areas
- Use in systems in which sporadic loads and vibrations or periodic forces act on the device
- The causing of hazardous operating conditions by a presetting on the electronic drive unit that is contrary to the process
- Use of accessories or spare parts that are not listed in these instructions

3 Product description

3.1 Function

The turbopump forms a compact unit with the electronic drive unit. The Pfeiffer Vacuum power supply packs serve as voltage supply.

The feature description "P" designates turbopumps suitable for the process. They are insensitive against dust and corrosive gases.

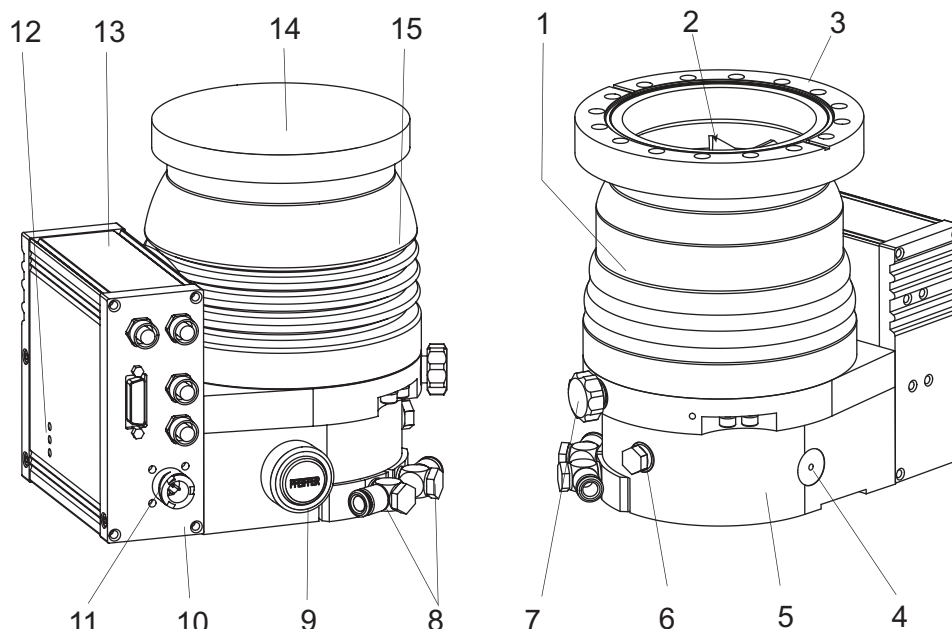

Fig. 3: Design 300 P (example DN 100 ISO-K and DN 100 CF-F)

- | | |
|---------------------------------------|--|
| 1 Pump housing, stainless steel | 9 Fore-vacuum connection, DN 16 ISO-KF (with protective cover) |
| 2 Turbo rotor | 10 Connecting panel of the electronic drive unit |
| 3 High vacuum connection, DN 100 CF-F | 11 Connecting plug for voltage supply DCin |
| 4 Ground terminal | 12 LED operating mode display |
| 5 Pump base | 13 Electronic drive unit TC 400 |
| 6 Sealing gas connection | 14 Protective cover for the high vacuum connection |
| 7 Venting screw | 15 Pump housing, aluminum |
| 8 Cooling water connection | |

3.1.1 Cooling

- Water cooling
- Air cooling (optional)

The electronic drive unit automatically regulates the drive power down in the event of excessive temperatures.

3.1.2 Rotor bearing

Hybrid-bearing turbopump

- High vacuum side: wear-free permanent magnetic bearing
- Fore-vacuum side: ball bearing with ceramic balls

Permanent lubrication of the rotor bearing on the fore-vacuum side is ensured by an operating fluid reservoir.

3.1.3 Drive

- Electronic drive unit TC 400
 - Operating voltage 24 V DC
- Electronic drive unit TC 400
 - Operating voltage 48 V DC

3.2 Shipment

- Turbopump with electronic drive unit
- Protective cover for the high vacuum connection
- Protective cover for the fore-vacuum connection
- Mating plug for the "remote" connection to the TC 400 (type-dependent)
- Mating plug for the "E74" connection to the TC 400 (type-dependent)
- Operating instructions

3.3 Identifying the product

- ▶ To ensure clear identification of the product when communicating with Pfeiffer Vacuum, always keep all of the information on the rating plate to hand.
- ▶ Learn about certifications through test seals on the product or at www.tuvdotcom.com with company ID no. [000021320](http://www.tuvdotcom.com).

3.3.1 Product types

The product designation of Pfeiffer Vacuum turbopumps from the HiPace series is composed of the family name, the size (which is based on the pumping speed of the vacuum pump) and, if required, an additional feature description.

Family	Size/model	Property, attribute, feature
HiPace	10 to 2800	none = Standard version
		mini = Compact version
		U = Overhead version
		C = Corrosive gas version
		P = Process
		M = Active magnetic bearing
		T = Temperature management
		E = High efficiency
		H = high compression
		I = ion implantation

Tbl. 3: Product designation of Pfeiffer Vacuum HiPace turbopumps

3.3.2 Product features

Feature	Version		
	DN 100 ISO-K	DN 100 ISO-F	DN 100 CF-F
HV flange	Aluminium	Aluminium	Stainless steel
Flange material	Aluminium	Aluminium	Stainless steel

Tbl. 4: Turbopump features

4 Transportation and Storage

4.1 Transport

WARNING

Danger of serious injury due to falling objects

Due to falling objects there is a risk of injuries to limbs through to broken bones.

- ▶ Take particular care and pay special attention when transporting products manually.
- ▶ Do not stack the products.
- ▶ Wear protective equipment, e.g. safety shoes.



Pfeiffer Vacuum recommends keeping the transport packaging and original protective cover.

Instructions for safe transport

1. Transport the turbopump only within the permissible temperature limits.
2. Observe weight specified on the rating plate.
3. Where possible, always transport or ship the turbopump in its original packaging.
4. Always carry the turbopump with both hands.
5. Remove the protective cover only immediately prior to installation.

4.2 Storage



Pfeiffer Vacuum recommends storing the products in their original transport packaging.

Storing the turbopump

1. Close all flange openings with the original protective caps.
2. Close all other connections (e.g. venting connection) with the respective original parts.
3. Store the turbopump only indoors within the permissible temperature limits.
4. In rooms with humid or aggressive atmospheres: Hermetically seal the turbopump together with a drying agent in a plastic bag.

5 Installation

The installation of the turbopump and its fastening is of outstanding importance. The rotor of the turbopump revolves at very high speed. In practice it is not possible to exclude the risk of the rotor touching the stator (e.g. due to the penetration of foreign bodies into the high vacuum connection). The kinetic energy released acts on the housing and on the anchoring of the turbopump within fractions of a second.

Comprehensive tests and calculations conforming to ISO 27892 confirm the safety of the turbopump both against crashes (destruction of the rotor blade) and against bursting (breakage of the rotor shaft). The experimental and theoretical results are expressed in safety measures and recommendations for the correct and safe fastening of the turbopump.

5.1 Preparatory work

⚠ WARNING

Risk of cuts on moving, sharp-edged parts when reaching into the open high vacuum flange

With the high vacuum flange open, access to sharp-edged parts is possible. A manual rotation of the rotor increases the danger situation. There is the risk of cuts, up to the separation of body parts (e.g. fingertips). There is a risk of hair and loose clothing being drawn in. Objects falling in destroy the turbopump during subsequent operation.

- ▶ Only remove the original protective covers immediately prior to connecting the high vacuum flange.
- ▶ Do not reach into the high vacuum connection.
- ▶ Wear protective gloves during installation.
- ▶ Do not start the turbopump with open vacuum connections.
- ▶ Always carry out the mechanical installation before electrical connection.
- ▶ Prevent access to the high vacuum connection of the turbopump from the operator side (e.g. open vacuum chamber).

General notes for the installation of vacuum components

- ▶ Choose an installation location that permits access to the product and to supply lines at all times.
- ▶ Observe the ambient conditions given for the area of use.
- ▶ Provide the highest possible level of cleanliness during assembly.
- ▶ Ensure that flange components during installation are grease-free, dust-free and dry.

Select the installation location

1. Observe the instructions for transport to the installation location.
2. Make sure that there are sufficient cooling options for the turbopump.
3. Install suitable shielding if the surrounding magnetic fields exceed the permissible levels.
4. Install suitable shielding so that the irradiated thermal output does not exceed the permissible values when high temperatures occur due to the process.
5. Observe the permissible temperatures for the vacuum connection.

5.2 Connecting the high vacuum side

5.2.1 Requirements for the dimensioning of a counter flange

NOTICE

Risk of damage due to incorrect counter flange design

Unevenness on the operator-side counter flange results in stresses in the vacuum pump housing, even when properly attached. This can produce leakage or negative changes in running characteristics.

- ▶ Adhere to the shape tolerances for the counter flange.
- ▶ Observe the maximum flatness deviations over the entire surface.



The assembly of vertical superstructural parts on the high vacuum connection is the responsibility of the operating company. The loading capacity of the high vacuum flange is specific for the turbopump used. The total weight of superstructural parts must not exceed the maximum values specified.

If the rotor is suddenly blocked, the torques arising from the system and the high vacuum flange must be absorbed. The installation elements for turbo pumps are special designs by Pfeiffer Vacuum.

Maximum torque occurring in the event of a burst ¹⁾	Maximum permissible axial load on the high vacuum flange ²⁾	Flatness	Minimum tensile strength of the flange material in all operating states	Engagement depth of the fixing screws	Maximum permissible surrounding magnetic field	Maximum permissible irradiated thermal output
2000 Nm	500 N (equivalent to 50 kg)	± 0.05 mm	170 N/mm ²	2.5 × d	5.5 mT	2.4 W
			270 N/mm ²	1.5 × d		

Tbl. 5: Requirements for the dimensioning of customer-specific high vacuum connection

Important information for correct installation

- ▶ Only use the approved mounting kits of Pfeiffer Vacuum for the high vacuum connection of the turbopump.

5.2.2 Considering earthquake protection

NOTICE

Vacuum pump damage caused by external vibrations

In the event of earthquakes or other external vibrations, there is the risk of the rotor coming into contact with the safety bearings, or the housing wall touching the turbopump. This can produce mechanical loads up to and including destruction of the turbopump.

- ▶ Make sure that all flange and safety connections absorb the resulting forces.
- ▶ Secure the vacuum chamber against displacement or tipping.

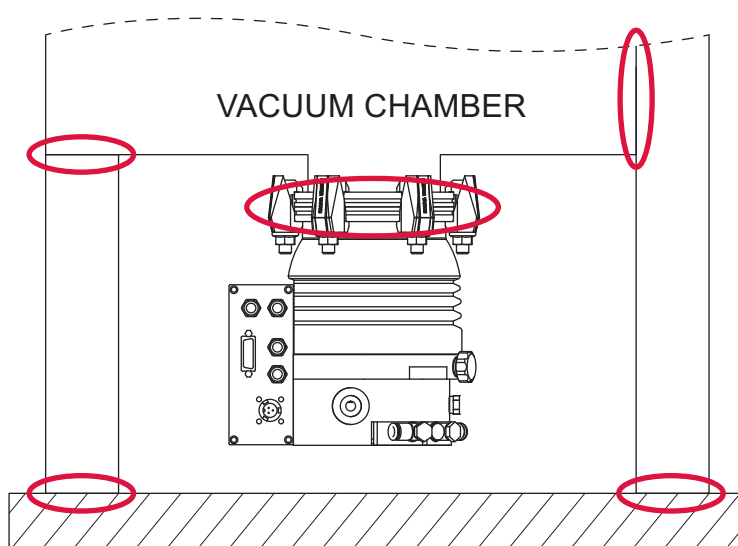



Fig. 4: Example: Safety connections

- 1) The theoretically calculated torque in the event of a burst (rotor shaft breakage) according to ISO 27892 was not reached in any experimental test.
- 2) A one-sided load is not permitted.

 Safety connection, customer-side

5.2.3 Using a splinter shield or protective screen

Pfeiffer Vacuum centering rings with splinter shield or protective screen in the high vacuum flange protect the Turbopump against foreign matter from the vacuum chamber. The pumping speed is reduced according to the passage guide values and the size of the high vacuum flange.

Flange size	Reduced pumping speed in % by gas type			
	H ₂	He	N ₂	Ar
Splinter shield DN 100	5	7	24	24
Protective screen DN 100	2	2	10	8

Tbl. 6: Reduction of the pumping speed when using a splinter shield or protective screen

- ▶ With ISO flanges, use centering rings with protective screen or splinter shield.

5.2.4 Using the vibration compensator

Pfeiffer Vacuum vibration compensators are suitable for use on vibration-sensitive systems.

WARNING

Risk of injury caused by the turbopump breaking away with the vibration compensator in the event of a malfunction

Sudden jamming of the rotor generates high destructive torques in accordance with ISO 27892. When using a vibration compensator, this will probably lead to the turbopump being sheared off in use. The energy that this would release could throw the entire turbopump or shattered pieces from its interior through the surrounding space. Potentially dangerous gases can escape. There is a risk of very serious injuries, including death, and extensive property damage.

- ▶ Take suitable safety precautions on-site for the compensation of the occurring torques.
- ▶ Before installing a vibration compensator, you must first of all contact Pfeiffer Vacuum.

Installing the vibration compensator

1. Install the vibration compensator only with vertical passage.
2. Consider the flow resistance.
3. Secure the turbopump additionally to the high vacuum flange.
4. Observe the fastening of the ISO flanges.

5.2.5 Mounting orientations

Pfeiffer Vacuum turbopumps from the HiPace series are suitable for use with dry compressing backing pumps for mounting in **all** orientations.

- ▶ When using oil-sealed backing pumps, avoid backflow from the fore-vacuum range.

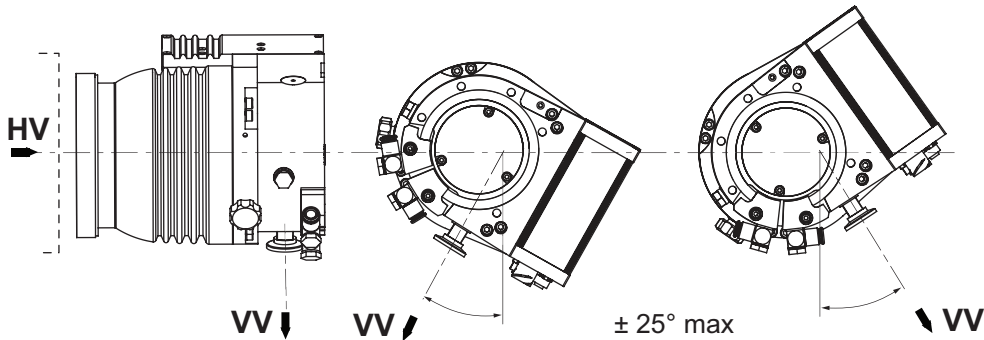

Fig. 5: Recommended alignment when using oil-sealed backing pumps

Specify a horizontal mounting orientation for oil-sealed backing pumps

1. Always align the fore-vacuum connection downwards vertically.
 - Permissible deviation $\pm 25^\circ$
2. Support the tube connections in front of the turbopump.
3. Do not allow any forces from the piping system to act on the turbopump.
4. Do not load the high vacuum flange of the turbopump on one side.

5.2.6 Attaching ISO-K flange onto ISO-K



ISO flange connections

For the connection of flanges in ISO-KF or ISO-K design, twisting may occur in the event of sudden blockage of the rotor, despite correct installation.

- Leak-tightness of the flange connection, however, is not jeopardized in this regard.

Required tools

- Wrench, WAF 15
- Calibrated torque wrench (Tightening factor ≤ 1.6)

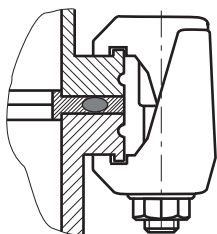

Fig. 6: Flange connection ISO-K to ISO-F, bracket screws

Connection with bracket screw

1. For the connection of the turbopump, use only the approved mounting kits from Pfeiffer Vacuum.
2. Connect the flange with the components of the mounting kit according to the figure.
3. Use for all prescribed components for the turbopump.
4. Tighten the bracket screws cross-wise in 3 steps.
 - Tightening torque: **5, 15, 25 \pm 2 Nm**

5.2.7 Attaching ISO-K flange to ISO-F

The connection types for the installation ISO-K flange with ISO-F flange are:

- "Hexagon head screw and tapped hole"
- "Stud screw with tapped hole"
- "Stud screw with through hole"



ISO flange connections

For the connection of flanges in ISO-KF or ISO-K design, twisting may occur in the event of sudden blockage of the rotor, despite correct installation.

- Leak-tightness of the flange connection, however, is not jeopardized in this regard.

Required tools

- Hexagon wrench (13 WAF)
- Calibrated torque wrench (tightening factor ≤ 1.6)

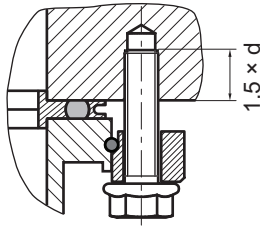

Fig. 7: Flange connection ISO-K with ISO-F, hexagon head screw and tapped hole

Connection of the hexagon head screw and tapped hole

1. Only use the approved mounting kits of Pfeiffer Vacuum for the connection of the turbopump.
2. Place the collar flange over the high vacuum flange of the turbopump.
3. Insert the snap ring in the side groove on the high vacuum flange of the turbopump.
4. Attach the turbopump with collar flange, snap ring and centering ring to the counter flange according to the figure.
5. Use all prescribed components for the turbopump.
6. Screw the hexagon head screws into the tapped holes.
 - Observe the minimum tensile strength of the flange material and the screw depth.
7. Fasten the hexagon head screws cross-wise in 3 steps.
 - Tightening torque: **5, 10, 16 ± 1 Nm**

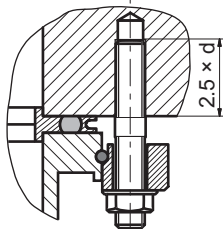

Fig. 8: Flange connection ISO-K with ISO-F, stud screw and tapped hole

Connection of the stud screw and tapped hole

1. Only use the approved mounting kits of Pfeiffer Vacuum for the connection of the turbopump.
2. Screw in the required number of stud screws with the shorter end in the holes on the counter flange.
 - Observe the minimum tensile strength of the flange material and the screw depth.
3. Place the collar flange over the high vacuum flange of the turbopump.
4. Insert the snap ring in the side groove on the high vacuum flange of the turbopump.
5. Attach the turbopump with collar flange, snap ring and centering ring to the counter flange according to the figure.
6. Use all prescribed components for the turbopump.
7. Secure the nuts cross-wise in 3 steps.
 - Tightening torque: **5, 10, 16 ± 1 Nm**

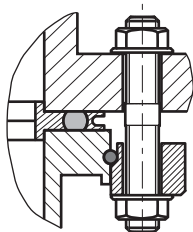

Fig. 9: Flange connection ISO-K with ISO-F, stud screw and through hole

Connection of the stud screw and through hole

1. Only use the approved mounting kits of Pfeiffer Vacuum for the connection of the turbopump.
2. Place the collar flange over the high vacuum flange of the turbopump.
3. Insert the snap ring in the side groove on the high vacuum flange of the turbopump.
4. Attach the turbopump with collar flange, snap ring and centering ring to the counter flange according to the figure.

5. Use all prescribed components for the turbopump.
6. Tighten the nuts cross-wise in 3 steps.
7. Tightening torque: **5, 10, 16 ± 1 Nm**

5.2.8 Attach ISO-F flange to ISO-F

The connection types for ISO-F flange installation with ISO-F flange are:

- "Hexagon head screw and tapped hole"
- "Stud screw with tapped hole"
- "Stud screw with through hole"

Required tools

- Hexagonal wrench (13 WAF)
- Calibrated torque wrench (tightening factor ≤ 1.6)

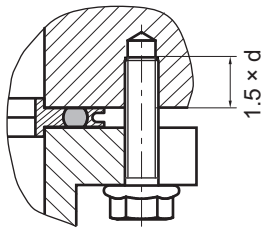

Fig. 10: Flange connection ISO-F, hexagon head screw and tapped hole

Connection of the hexagon head screw and tapped hole

1. Only use the approved mounting kits of Pfeiffer Vacuum for the connection of the turbopump.
2. Attach the turbopump with centering ring to the counter flange according to the figure.
3. Use all prescribed components for the turbopump.
4. Screw the required number of hexagon head screws into the tapped hole.
 - Observe the minimum tensile strength of the flange material and the screw depth.
5. Fasten the hexagon head screws cross-wise in 3 steps.
 - Tightening torque: **5, 15, 22 ± 2 Nm**

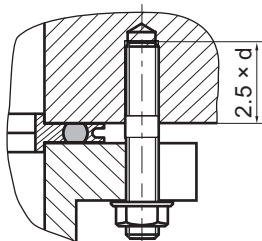

Fig. 11: Flange connection ISO-F, stud screw and tapped hole

Connection of the stud screw and tapped hole

1. Only use the approved mounting kits of Pfeiffer Vacuum for the connection of the turbopump.
2. Screw in the stud screws with the shorter end in the tapped holes on the counter flange.
 - Observe the minimum tensile strength of the flange material and the screw depth.
3. Attach the turbopump with centering ring to the counter flange according to the figure.
4. Use all prescribed components for the turbopump.
5. Secure the hexagon nuts.
6. Tighten the nuts cross-wise in 3 steps.
 - Tightening torque: **5, 15, 22 ± 2 Nm**

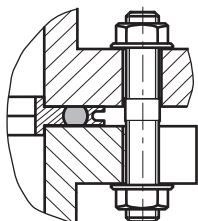

Fig. 12: Flange connection ISO-F, stud screw and through hole

Connection of the stud screw and through hole

1. Only use the approved mounting kits of Pfeiffer Vacuum for the connection of the turbopump.
2. Attach the turbopump with collar flange, snap ring and centering ring to the counter flange according to the figure.
3. Use all prescribed components for the turbopump.
4. Fasten the screw connections cross-wise in 3 steps.
 - Tightening torque: **10, 20, 22 ± 3 Nm**

5.2.9 Fastening CF flange to CF-F

The connection types for CF installation with CF flange are:

- "Hexagon head screw and through hole"
- "Stud screw with tapped hole"
- "Stud screw with through hole"

NOTICE

Leaks may occur due to the incorrect installation of CF flanges

Inadequate cleanliness when handling CF flanges and copper gaskets results in leaks and may cause process damage.

- ▶ Always wear suitable gloves before touching or fitting any components.
- ▶ Fit seals only if dry and free of grease.
- ▶ Take care of damaged surfaces and cut edges.
- ▶ Replace the damaged components.

Required tools

- Hexagonal wrench (13 WAF)
- Calibrated torque wrench (tightening factor ≤ 1.6)

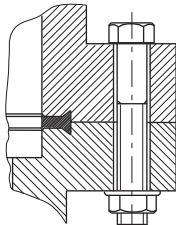

Fig. 13: Flange connection CF-F, hexagon head screw and through hole

Connection of the hexagon head screw and through holes

1. For the connection of the turbopump, use only the approved mounting kits from Pfeiffer Vacuum.
2. If used: Insert the protective screen or splinter shield with clamping lugs downwards in the turbopump high vacuum flange.
3. Place the seal exactly in the hollow.
4. Connect the flange with the components of the mounting kit according to the figure.
5. Tighten the screw couplings all the way around.
 - Tightening torque: **22 ± 2 Nm**
6. Then check the torque, since flowing of the sealing material may make it necessary to re-tighten the screws.

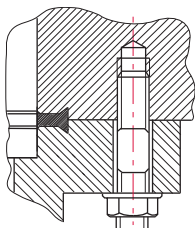

Fig. 14: Flange connection CF-F, stud screw and tapped hole

Connection of the stud screw and tapped hole

1. For the connection of the turbopump, use only the approved mounting kits from Pfeiffer Vacuum.
2. Screw in the required number of stud screws with the shorter end in the holes on the counter flange.
3. If used: Insert the protective screen or splinter shield with clamping lugs downwards in the turbopump high vacuum flange.
4. Place the seal exactly in the hollow.
5. Connect the flange with the components of the mounting kit according to the figure.
6. Tighten the screw couplings all the way around.
 - Tightening torque: **22 ± 2 Nm**
7. Then check the torque, since flowing of the sealing material may make it necessary to re-tighten the screws.

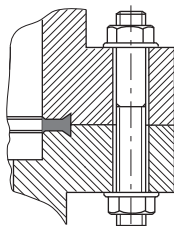

Fig. 15: Flange connection CF-F, stud screw and through hole

Connection of the stud screw and through hole

1. For the connection of the turbopump, use only the approved mounting kits from Pfeiffer Vacuum.
2. If used: Insert the protective screen or splinter shield with clamping lugs downwards in the turbopump high vacuum flange.
3. Place the seal exactly in the hollow.
4. Connect the flange with the components of the mounting kit according to the figure.
5. Tighten the screw couplings all the way around.
 - Tightening torque: **22 ± 2 Nm**
6. Then check the torque, since flowing of the sealing material may make it necessary to re-tighten the screws.

5.3 Connecting the fore-vacuum side

WARNING

Danger to life from poisoning where toxic process media leak from damaged connections

Sudden twisting of the turbopump in the event of a fault causes fittings to accelerate. There is the risk of damaging on-site connections (e.g., fore-vacuum line) and resulting leaks. This results in leakage of process media. In processes involving toxic media, there is a risk of injury and danger to life due to poisoning.

- ▶ Keep masses connected to the turbopump as low as possible.
- ▶ Use flexible lines to connect to the turbopump where necessary.



Suitable backing pump

Use the turbopump only in combination with a suitable backing pump that can deliver up to the required maximum fore-vacuum pressure. To achieve the fore-vacuum pressure, use a suitable vacuum pump or a pumping station from the Pfeiffer Vacuum range.

In this case, the backing pump is also controlled directly via the turbopump electronic drive unit interfaces (e.g., relay box or connection cable).

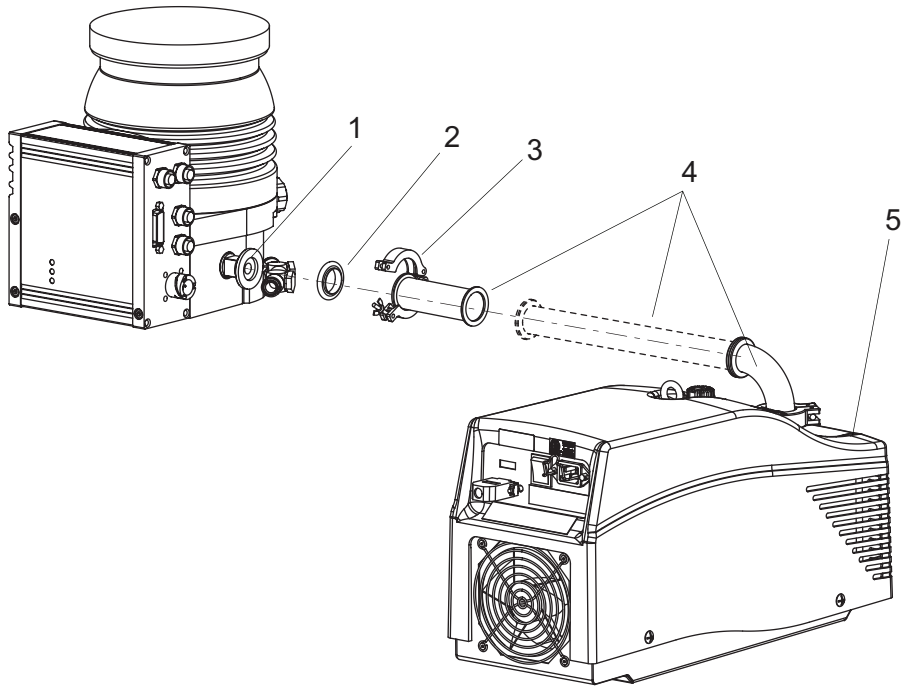

Fig. 16: Example of fore-vacuum connection on HiPace 300

- | | |
|------------------------------------|---|
| 1 Turbopump fore-vacuum connection | 4 Vacuum components DN 16 ISO-KF |
| 2 Centering ring | 5 Backing pump (e.g. multi-stage roots vacuum pump) |
| 3 Circlip | |

Establishing the fore-vacuum connection

1. With rigid pipe connections, include bellows to attenuate external vibrations.
2. Install a fore-vacuum connection with small flange components, e.g. connection elements and pipe components DN 16 ISO-KF from the [Pfeiffer Vacuum Components Shop](#).
3. Implement measures to counteract the backflow of operating fluids or condensate from the fore-vacuum area.
4. Observe the information in the operating instructions of the backup pump or pumping station when connecting and operating it.

5.4 Cooling water connection

The HiPace 300 turbopumps use water cooling as standard.

⚠ WARNING

Risk of scalding from suddenly escaping hot cooling water

The turbopump water connections are open to both sides. When connecting the cooling water supply, there is a risk of scalding from suddenly escaping, hot cooling water at over pressure.

- ▶ Prior to installation, ensure that pressure is discharged from the cooling water system, and that it is cooled down.
- ▶ Wear protective equipment, e.g., safety goggles and gloves.

Recommendations for cooling the turbopump

1. Use additional cooling in the event of increased fore-vacuum pressure (> 0.1 hPa).
2. Use additional cooling if operating with high gas throughput.
3. Always use water cooling at ambient temperatures > 35 °C.

Parameter	Cooling water
Appearance	<ul style="list-style-type: none"> • filtered • mechanically clear • visually clear • no turbidity • no sediment • free from grease and oil
pH value	7 to 9
Carbonate hardness, max.	10 °dH 12.53 °e 17.8 °fH 178 ppm CaCO ₃
Chloride content, max.	100 mg/l
Sulfate content, max.	240 mg/l
Carbonic acid content, max.	not detectable
Ammonia content, max.	not detectable
Electrical conductivity, max.	500 µS/cm
Particle size, max.	150 µm
Cooling water temperature	See "Technical data"
Cooling water consumption	See "Technical data"
Feed line overpressure, max.	6000 hPa

Tbl. 7: Requirements on the cooling water composition

Connection to the turbopump	External cooling water supply
Banjo fitting with insertion system	Hose cable
	External hose diameter 8 mm
	Internal hose diameter 6 mm

Tbl. 8: Requirements on the cooling water connection

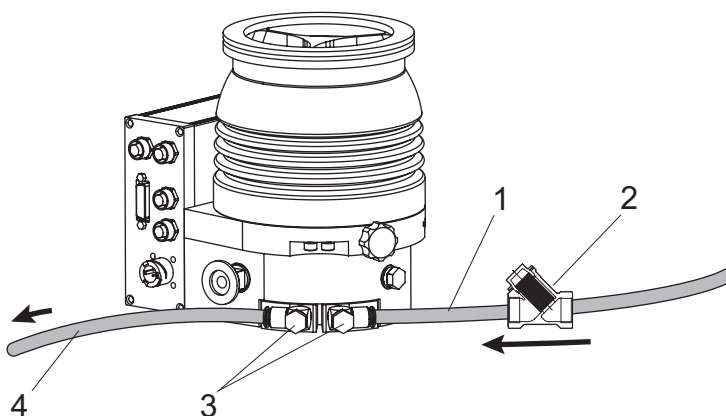

Fig. 17: Connecting the cooling water supply

- 1 Feed line
- 2 Dirt trap
- 3 Cooling water connection
- 4 Return line

Required tools

- Hexagon wrench (14 WAF)

- Calibrated torque wrench (tightening factor ≤ 1.6)

Connecting a cooling water supply

Requirements: The customer-side cooling system is closed and depressurized. The provided hose connections correspond to the turbopump connections.

1. If necessary, use a dirt trap in the feed line.
2. Insert the hoses for the cooling water feed line and return line as far as they will go into respective connections on the turbopump.
3. Adjust the banjo fittings according to your requirements.
 - Tightening torque for the banjo fitting: **3 to 3.5 Nm**

5.5 Connecting accessories



Installation and operation of accessories

Pfeiffer Vacuum offers a series of special, compatible accessories for its products.

- Information and ordering options for approved accessories can be found online.
- The following accessories are not included in the scope of supply.

5.5.1 Connecting accessories to the turbopumps



Electronic drive unit TC 400 accessory connection

The electronic drive unit of the turbopump offers space for the connection of maximum 4 accessory devices. M12 sockets with the designation "accessory" are available for this purpose.

- The accessory connections have been preconfigured at the factory.
- After connecting pre-configured accessory devices, these are immediately ready for operation according to the factory settings.
- The use of other accessories for turbopumps is possible and requires settings in the configuration of the electronic drive unit.
- The desired accessory output is configured via RS-485 using Pfeiffer Vacuum display and control units or a PC.
- You can find more detailed information in the "Electronic drive unit TC|400" operating manual.

	Electronic drive unit connection	Accessory connection	Y-connector	Pre-set configuration
	Acc. A	A1	Y-1	Fan (continuous operation)
		A2	Y-2	backing pump
	Acc. B	B1	Y-1	Venting valve
		B2	Y-2	Heater

Tbl. 9: Factory pre-set accessory connections on the electronic drive unit

Connecting accessory devices

1. Observe the installation instructions in the operating instructions for the relevant accessory.
2. Note the existing configuration of existing connections and control lines.
3. Connect only matching accessory devices to the electronic drive unit.
4. Use the Y-connector from the scope of supply if you want to connect 3 or 4 devices.

Using additional accessories

1. Observe the installation instructions in the operating instructions for the relevant accessory.
2. Note the existing configuration of existing connections.
3. Use the Pfeiffer Vacuum display and control unit DCU 002, or a DCU with integrated power supply pack.

5.5.2 Connecting the venting valve

A Pfeiffer Vacuum venting valve serves the automatic venting of a turbopump after switching off or in event of a power failure.

- The permissible inlet pressure for venting gas is 1,500 hPa absolute.

Connecting the venting valve

1. Unscrew the venting screw with sealing ring out of the turbopump by hand.
2. Screw the venting valve with the outlet side into the venting connection of the turbopump.
3. Screw the control line of the venting valve into the corresponding connection on the electronic drive unit.

Establish the venting gas supply

In case you want to use dry room air as venting gas, the venting valve is ready for operation immediately.

In case you want to use another inert gas (e.g. nitrogen N_2) as venting gas, follow the handling steps.

1. Provide an external venting gas supply with a maximum inlet pressure of 1,500 hPa absolute.
2. Connect the venting gas supply to the inlet side (G 1/8") of the valve.
3. If required, use a connecting adapter from the accessory of the valve (not included in the scope of supply).

5.5.3 Connecting the air cooling



Operational conditions for the air cooling

Air cooling is permitted up to a permissible ambient temperature of + 35 °C!

For processes with smaller gas loads and good fore-vacuum pressure, air cooling (optional) is possible instead of water cooling.

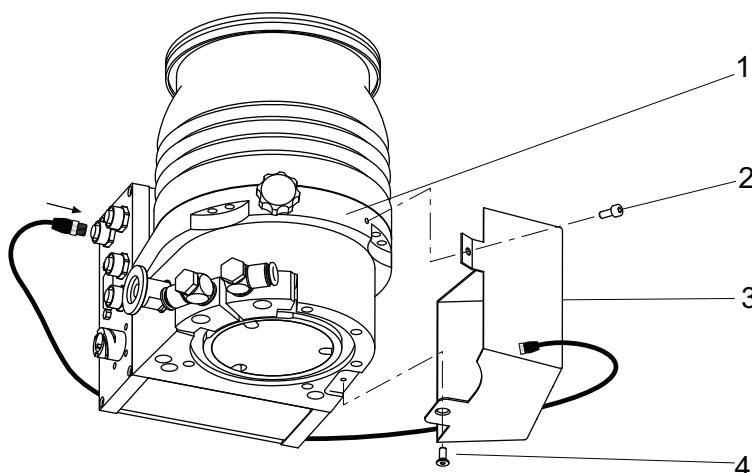

Fig. 18: Connecting the air cooling

- | | |
|--------------------|---------------------|
| 1 Pump base | 3 Air cooling |
| 2 Allen head screw | 4 Countersunk screw |

Required tools

- Allen key, size 2.5
- Allen key, size 3

Procedure

1. Attach the air cooling to the intended bores on the pump base with 2 screws.
2. Screw the control line of the sealing gas valve into a free accessory connection on the electronic drive unit.
3. If necessary, configure the accessory output for the sealing gas via the interfaces of the electronic drive unit.
 - The specification for the air cooling is "accessory A1".

5.5.4 Connecting sealing gas

The use of sealing gas serves to protect the turbopump in dusty processes, corrosive processes or with excessive gas throughputs. Sealing gas prevents the ingress of damaging substances into the motor and bearing area. The supply is carried out either via a sealing gas valve or a sealing gas throttle without control.

- Pfeiffer Vacuum recommends the use of sealing gas from 50 % of the maximum gas throughput.
- The permissible inlet pressure for sealing gas is 1,500 hPa absolute.
- The flow rate for sealing gas is at 12.5 to 15 sccm.

Connecting the sealing gas valve

1. Unscrew the screw plug with sealing ring out of the sealing gas connection of the turbopump.
2. Screw the sealing gas valve with the outlet side into the sealing gas connection of the turbopump.
3. Screw the control line of the sealing gas valve into a free accessory connection on the electronic drive unit.
4. Configure the accessory output for the sealing gas via the interfaces of the electronic drive unit.

Connecting the sealing gas throttle without control valve

1. Unscrew the screw plug with sealing ring out of the sealing gas connection of the turbopump.
2. Screw the sealing gas throttle with the outlet side into the sealing gas connection of the turbopump.

Establishing the sealing gas supply

In case you want to use room air as sealing gas, the sealing gas valve is ready for operation immediately.

In case you want to use another inert gas (e.g. nitrogen N₂) as sealing gas, follow the handling steps.

1. Provide an external sealing gas supply with a maximum inlet pressure of 1,500 hPa absolute.
2. Connect the sealing gas supply to the inlet side (1/8" thread) of the valve.
3. If required, use a connecting adapter from the accessory of the valve (not included in the scope of supply).

5.5.5 Installing a heating jacket

NOTICE

Vacuum pump destruction due to excessive energy input during operation

Simultaneous loading by means of high drive power (gas throughput, fore-vacuum pressure), high heat radiation, or strong magnetic fields results in uncontrolled heating of the rotor and can destroy the vacuum pump.

- ▶ Consult Pfeiffer Vacuum before combining varying loads on the vacuum pump. Lower limit values apply.



Operational conditions for the housing heating

- When using housing heating and water cooling, the max. permissible temperature at the connection flange of the vacuum chamber is 120°C.
- The maximum permissible rotor temperature is 110 °C.

For high temperatures that occur due to the process, the thermal output irradiated must not exceed 2.4 W. If necessary, install suitable screening sheets (information on request).

The turbopump and vacuum chamber must be baked out to reach the ultimate pressure more quickly. The heating jacket may only be used in turbopumps with high vacuum flange in stainless steel design. The heating duration depends on the degree of contamination in the process, as well as the final pressure to be reached, and should be at least 4 hours.

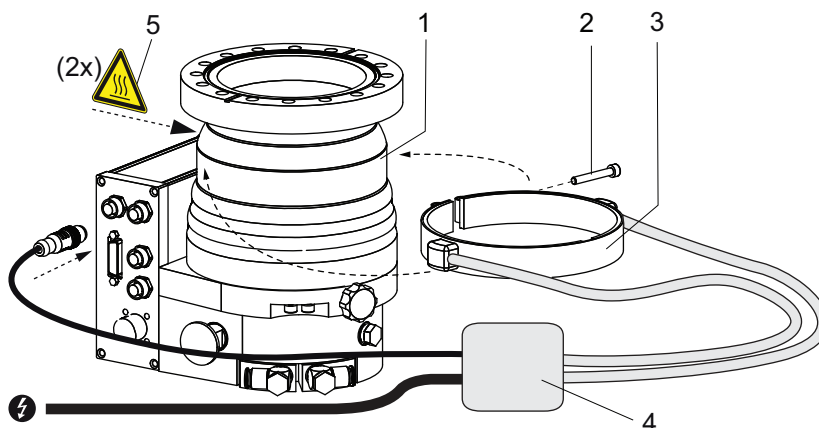

Fig. 19: Connection of the heating jacket

- 1 Pump housing
- 2 Allen head screw
- 3 Heating jacket
- 4 Heating relay box
- 5 "Hot surface" warning sticker

Required tools

- Allen key, size 4 or 5

Installing a heating jacket

1. Carefully bend out the heating jacket at the outer clamping strap.
2. Push the jacket onto the cylindrical section of the pump body from the side.
3. Care should be taken that the heater bands do not become deformed and that the jacket is resting flush against the body.
4. Secure the heating jacket onto the body with the Allen head screw.
5. Apply the sticker "Hot surface" on the pump housing.
6. Install suitable shielding plates as protection against the irradiated heat input exceeding the maximum values.

Fixing screw thread	Tightening torque in cold condition	Tightening torque for bakeout	One-time retightening after cooling
M5	6 Nm	7 Nm	7 Nm
M6	11 Nm	12 Nm	12 Nm

Tbl. 10: Tightening torque for heating jacket fastening screws

Connecting the control line

1. Connect the accessory control line to the electronic drive unit using the corresponding accessory connection, and tighten the plug securely.
2. Check the specification in the configuration "accessory B1".
3. Establish the power supply for the relay box in accordance with the operating instructions for the accessory.

5.6 Connecting the electrical supply

⚠ WARNING

Risk of danger to life through missing mains disconnection device

The vacuum pump and electronic drive unit are **not** equipped with a mains disconnection device (mains switch).

- ▶ Install a mains disconnection device according to SEMI-S2.
- ▶ Install a circuit breaker with an interruption rating of at least 10,000 A.

⚠ WARNING

Risk of injury due to incorrect installation

Dangerous situations may arise from unsafe or incorrect installation.

- ▶ Do not carry out your own conversions or modifications on the unit.
- ▶ Ensure the integration into an Emergency Off safety circuit.

5.6.1 Earthing the pump

Pfeiffer Vacuum recommends connecting a suitable grounding cable to discharge applicative interferences.

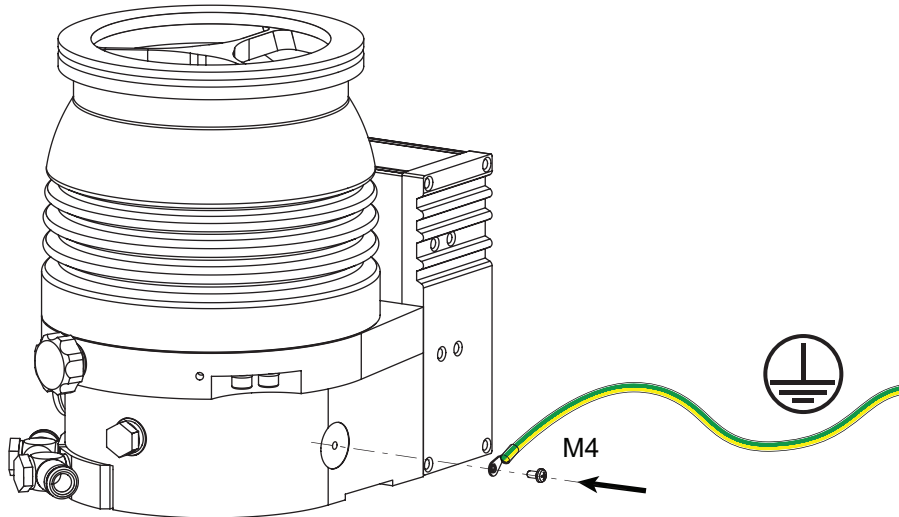

Fig. 20: Example: Connecting the grounding cable

Procedure

1. Use the turbopump ground terminal (M4 female thread).
2. Route the connection in accordance with locally applicable provisions.

5.6.2 Create electrical connection

⚠ DANGER

Danger to life from electric shock

Power supply packs that are not specified or are not approved will lead to severest injuries up to death.

- ▶ Make sure that the power supply pack meets the requirements for double isolation between mains input voltage and output voltage, in accordance with IEC 61010 and IEC 60950.
- ▶ Make sure that the power supply pack meets the requirements in accordance with IEC 61010 and IEC 60950.
- ▶ Where possible, use original power supply packs or only power supply packs that correspond with the applicable safety regulations.

⚠ WARNING

Danger to life from electric shock in the event of a fault

In the event of a fault, devices connected to the mains may be live. There is a danger to life from electric shock when making contact with live components.

- ▶ Always keep the mains connection freely accessible so you can disconnect it at any time.

⚠ WARNING**Danger of cut injuries from unexpected start up.**

The use of mating plugs of the electronic drive unit (accessories) enables the automatic run-up of the vacuum pump as soon the power is turned on. Attaching mating plugs before or during the installation leads to the movement of parts hence the risk of cut injuries by sharp-edged in the exposed high vacuum flange.

- ▶ Only connect mating plugs after the mechanical installation.
- ▶ Only switch on the vacuum pump immediately prior to operation.

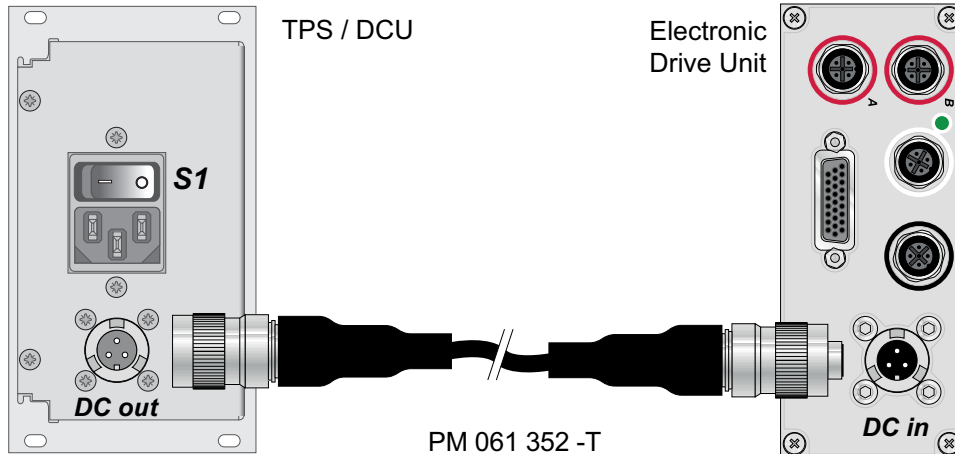

Fig. 21: Connecting the electronic drive unit to a power supply pack

Connecting the electronic drive unit

1. Make sure that you have the correct supply voltage.
2. Make sure that the power supply pack main switch is off prior to connection.
3. Use a matching connecting cable from the Pfeiffer Vacuum accessories program.
4. Insert the connecting cable into the connection "DCin" on the electronic drive unit and close the bayonet lock.
5. Insert the connecting cable into the connection "DCout" on the power supply pack and close the bayonet lock.

6 Operation

6.1 Commissioning

Important settings and function-related variables are factory-programmed into the vacuum pump electronic drive unit as parameters. Each parameter has a three-digit number and a description. Parameter-driven operation and control is supported via Pfeiffer Vacuum displays and control units, or externally via RS-485 using Pfeiffer Vacuum protocol.

⚠ WARNING

Danger of cut injuries from unexpected start up.

The use of mating plugs of the electronic drive unit (accessories) enables the automatic run-up of the vacuum pump as soon the power is turned on. Attaching mating plugs before or during the installation leads to the movement of parts hence the risk of cut injuries by sharp-edged in the exposed high vacuum flange.

- ▶ Only connect mating plugs after the mechanical installation.
- ▶ Only switch on the vacuum pump immediately prior to operation.

NOTICE

Vacuum pump destruction due to excessive energy input during operation

Simultaneous loading by means of high drive power (gas throughput, fore-vacuum pressure), high heat radiation, or strong magnetic fields results in uncontrolled heating of the rotor and can destroy the vacuum pump.

- ▶ Consult Pfeiffer Vacuum before combining varying loads on the vacuum pump. Lower limit values apply.

NOTICE

Turbopump destruction due to gases with too high molecular masses

The pumping of gases with impermissible high molecular masses leads to the destruction of the turbopump.

- ▶ Make sure that the gas mode is set correctly by **[P:027]** in the electronic drive unit.
- ▶ Consult Pfeiffer Vacuum before you use gases with higher molecular masses (> 80).

Parameter	Name	Designation	Adjustment, setting
[P:027]	GasMode	Gas mode	0 = heavy gases
[P:035]	CfgAccA1	Accessory connection A1	0 = fan (continuous operation)
[P:036]	CfgAccB1	Accessory connection B1	1 = Venting valve
[P:037]	CfgAccA2	Accessory connection A2	3 = backing pump
[P:038]	CfgAccB2	Accessory connection B2	2 = heating
[P:700]	RUTimeSVal	Set value run-up time	8 min.
[P:701]	SpdSwPt1	Rotation speed switch point 1	80 %
[P:707]	SpdSVal	Speed-control operation specification	65 %
[P:708]	PwrSVal	Set value power consumption	100 %
[P:720]	VentSpd	Venting at rotation speed, delayed venting	50 %
[P:721]	VentTime	Venting time, delayed venting	3600 sec.

Tbl. 11: Factory setting of the electronic drive unit when delivered

Notes for turbopump commissioning

1. Observe the cooling water flow and flow rate.
2. When using sealing gas, observe the sealing gas flow and throughput.

3. Observe the reduction of the drive power depending on the mains connection voltage provided.
4. Provide the current supply for the product.

6.2 Operating modes

The turbopump can be operated in different modes.

- Operation without control unit
- Operation via connection "E74"
- Operation via "remote" connection
- Operation via interface RS-485 and Pfeiffer Vacuum display and control unit or PC
- Operation via field bus

6.2.1 Operation without operating unit



Automatic start

When using the supplied mating plug on the electronic drive unit or bridging contacts according to the terminal lay-out, the turbopump is ready for operation. Once the supply voltage is provided, the turbopump starts up immediately.

Instructions for operation without control panel

1. Use only the approved Pfeiffer Vacuum mating plug with bridges on the connection of the electronic drive unit.
2. Switch on the mains supply of the turbopump only immediately before operation.

After applying the operating voltage, the electronic drive unit carries out a self-test to check the supply voltage. After completing the self-test successfully, the turbopump starts and activates connected additional equipment according to the configuration.

6.2.2 Operation via multi-function connection "remote"

Remote control is available via the 26-pole D-sub connector with the "remote" designation on the electronic drive unit. The accessible individual functions are mapped to "PLC levels".

Instructions for remote control operation

- ▶ See the operating manual of the electronic drive unit for the standard version.

6.2.3 Operation via connection "E74"

Operation is possible via the 15-pole D-sub connection with the "E74" designation on the electronic drive unit. Besides the signals defined in the Directive SEMI E74-0301, the connection is provided with an inverted alarm signal and an analog output.

Instructions for operation with E74

- ▶ See the operating manual of the electronic drive unit with E74 version.

6.2.4 Operation via Pfeiffer Vacuum display and control unit

The connection of a Pfeiffer Vacuum display and control panel permits the controlling of the turbopump via the parameters fixed in the electronic drive unit.

Instructions for operation with display and control unit

1. When handling the Pfeiffer Vacuum display and control unit, observe the associated operating instructions:
 - "DCU" operating instructions available from the [Pfeiffer Vacuum Download Center](#).
 - "HPU" operating instructions available from the [Pfeiffer Vacuum Download Center](#).
2. Observe the electronic drive unit operating instructions from the turbopump scope of delivery.
3. Connect the display and control unit to the connection "RS-485" on the electronic drive unit.

6.2.5 Operation via field bus

Integrating and operating Pfeiffer Vacuum turbopumps in the customer's field bus system is possible when using an electronic drive unit with a corresponding connection panel.

The following are available:

- Profibus
- EtherCAT
- DeviceNet

Instructions for field bus operation

- ▶ See the operating manual of the electronic drive unit with corresponding connection panel.

6.3 Switching on the turbopump

WARNING

Danger of cut injuries from unexpected start up.

The use of mating plugs of the electronic drive unit (accessories) enables the automatic run-up of the vacuum pump as soon the power is turned on. Attaching mating plugs before or during the installation leads to the movement of parts hence the risk of cut injuries by sharp-edged in the exposed high vacuum flange.

- ▶ Only connect mating plugs after the mechanical installation.
- ▶ Only switch on the vacuum pump immediately prior to operation.

WARNING

Risk of burns on hot surfaces when using additional equipment for heating during operation

The use of additional equipment for heating the vacuum pump or for optimizing the process generates very high temperatures on surfaces that can be touched. There is a risk of burning.

- ▶ If necessary, set up a contact guard.
- ▶ If necessary, apply the warning stickers provided for this at the danger points.
- ▶ Ensure adequate cooling down before working on the vacuum pump or in its vicinity.
- ▶ Wear protective equipment, e.g., gloves.

WARNING

Risk of serious injury in the event of vacuum pump destruction due to over pressure

Gas entry with very high over pressure results in destruction of the vacuum pump. There is a risk of serious injury due to ejected objects.

- ▶ Never exceed the permissible 1500 hPa (absolute) inlet pressure on the suction side or the venting and sealing gas connection.
- ▶ Make sure that high, process-related over pressures cannot directly enter the vacuum pump.











Switching on the turbopump

- ▶ Connect the power supply pack to the mains power supply on the customer-side.
- ▶ Switch on the power supply pack.

6.4 Operation monitoring

6.4.1 Operating mode display via LED

LEDs on the electronic drive unit indicate basic operating conditions of the turbopump. A differentiated malfunction and warning display is possible only for operation with DCU or HPU.

LED	Symbol	LED status	Display	Meaning
Green 		Off	—	without current
		On, flashing		"Pumping station OFF", rotation speed $\leq 60 \text{ rpm}^{-1}$
		On, inverse flashing		"Pumping station ON", set rotation speed not reached
		On, constant		"Pumping station ON", set rotation speed reached
		On, flashing		"Pumping station OFF", speed $> 60 \text{ rpm}^{-1}$
Yellow 		Off	—	no warning
		On, constant		Warning
Red 		Off	—	no error, no warning
		On, constant		Malfunction, error

Tbl. 12: Behavior and meaning of the LEDS of the electronic drive unit

6.4.2 Temperature monitoring

If threshold values are exceeded, output signals from temperature sensors allow the turbopump to be switched to a safe condition. Depending on the type, temperature thresholds for warning and malfunction messages are stored immutably in the electronic drive unit. For information purposes, various status requests are set up in the parameter set.

- If the excess temperature warning threshold is exceeded, the electronics reduce the turbopump drive power with the aim of avoiding shutdown.
 - Examples are an impermissible motor temperature, or impermissibly high housing temperature.
- Further reduction of drive power and thus decreasing speed can potentially lead to the set rotation speed switchpoint not being met, and thus to the turbopump switching off.
- If the error threshold for excess temperature is exceeded, the turbopump switches off immediately.

6.5 Switching off and venting



We recommend

Vent the turbopump after shutdown. By doing so, you prevent particles flowing back into the vacuum system from the fore-vacuum area.

6.5.1 Switching off

Notes for switching off the turbopump

1. Shut down the turbopump via the control unit or remote control.
2. Close the fore-vacuum line.
3. Switch off the backing pump, if necessary.
4. Vent the turbopump (options see below).
5. Close the supply lines (e.g. for cooling water or sealing gas).

6.5.2 Venting

NOTICE

Damage to the turbopump due to non-permissibly fast pressure rise during venting

Non-permissibly high pressure rise rates place a significant load on the rotor and the magnetic bearing of the turbopump. During venting very small volumes in the vacuum chamber or the turbopump, there is a risk of uncontrollable pressure rises. This causes mechanical damage to the turbopump, including potential failure.

- ▶ Observe the prescribed maximum pressure rise speed of **15 hPa/s**.
- ▶ Avoid manual and uncontrolled venting of very low volumes.
- ▶ Where necessary, use a venting valve from the Pfeiffer Vacuum range of accessories.

Manual venting

Manual venting describes the standard process for venting the turbo pumping station.

1. Ensure that the vacuum system is shut down.
2. Open the black venting screw on the turbopump by one revolution maximum.
3. Wait for pressure equalization to atmospheric pressure in the vacuum system.
4. Close the venting screw again.

Use a Pfeiffer Vacuum venting valve

The Pfeiffer Vacuum venting valve is an optional accessory for installation on the turbopump.

The venting valve is normally closed. Control is via the turbopump electronic drive unit, and configuration of parameters **[P:012]** and **[P:030]**. In the event of a power failure, the turbopump continues to deliver sufficient energy during its run-down period to initiate a proper venting process. When power is restored, the venting process is interrupted.

- ▶ Switch off the turbopump.
 - The venting process starts automatically.

Venting speed [P:720]	Venting duration [P:721]	Venting duration in the event of a power failure
50 % of rated speed	3600 s	3600 s

Tbl. 13: Factory settings for delayed venting of turbopumps

General information for fast venting

We recommend fast venting of larger volumes in 4 steps.

1. Use a Pfeiffer Vacuum venting valve for the turbopump, or match the valve cross-section to the size of the recipient and maximum venting rate.
2. Vent the vacuum system with a maximum rate of pressure rise of **15 hPa/s** for a duration of 20 seconds.
3. Then vent the system with a second venting valve of any size, for example directly at the vacuum chamber.
4. Wait for pressure equalization to atmospheric pressure in the vacuum system.

7 Maintenance

7.1 General maintenance information

WARNING

Danger to life from electric shock during maintenance and service work

The device is only completely de-energized when the mains plug has been disconnected and the turbopump is at a standstill. There is a danger to life from electric shock when making contact with live components.

- ▶ Before performing all work, switch off the main switch.
- ▶ Wait until the turbopump comes to a standstill (rotation speed =0).
- ▶ Remove the mains plug from the device.
- ▶ Secure the device against unintentional restarting.

WARNING

Health hazard through poisoning from toxic contaminated components or devices

Toxic process media result in contamination of devices or parts of them. During maintenance work, there is a risk to health from contact with these poisonous substances. Illegal disposal of toxic substances causes environmental damage.

- ▶ Take suitable safety precautions and prevent health hazards or environmental pollution by toxic process media.
- ▶ Decontaminate affected parts before carrying out maintenance work.
- ▶ Wear protective equipment.

7.2 Maintenance intervals and responsibilities

Recommendations for performing maintenance measures

1. Clean the turbopump exterior with a lint-free cloth and a little isopropanol.
2. Replace the electronic drive unit as an independent unit.
3. Replace the operating fluid reservoir as an independent unit.
4. Pay attention to when the operating fluid must be changed.
5. Change the operating fluid reservoir at least every 4 years.
6. Have Pfeiffer Vacuum Service replace the rotor bearing of the turbopump at least every 4 years.
7. Consult with Pfeiffer Vacuum Service about shorter maintenance intervals for extreme loads or impure processes.
8. For all other cleaning, maintenance or repair work, contact the appropriate Pfeiffer Vacuum Service location.

7.3 Replacing the operating fluid reservoir

WARNING

Risk of poisoning from contact with harmful substances

The operating fluid reservoir and parts of the turbopump may contain toxic substances from pumped media.

- ▶ Decontaminate affected parts before carrying out maintenance work.
- ▶ Prevent health hazards or environmental impacts with adequate safety precautions.
- ▶ Observe the operating fluid safety data sheet.
- ▶ Dispose of the operating fluid reservoir according to applicable regulations.

NOTICE

Damage to sealing surfaces from unsuitable tools

The use of unsuitable tools for removal or insertion of sealing rings damages the sealing surfaces, causing vacuum pump leakage.

- ▶ Never use sharp, metallic tools (e.g., tweezers).
- ▶ Remove sealing rings by hand only, or with wooden or plastic sticks if necessary.

You can find the safety data sheet can in the [Pfeiffer Vacuum Download Center](#).

Preparatory work

1. Do not apply any mechanical loads to the electronic drive unit.
2. Switch off the turbopump (see chapter “Switching off”, page 39).
3. Vent the vacuum system to atmospheric pressure (see chapter “Venting”, page 40).
4. Interrupt the electric supply.
5. Remove all cables from the electronic drive unit.
6. **If dismantling the turbopump from the system:** Close all openings with the original protective covers and screw plugs.

Required tools

- Allen key, WAF 5 mm
- Tweezers
- Toothpick
- Calibrated torque wrench (tightening factor ≤ 1.6)

Required consumables

- Clean, lint-free cloth

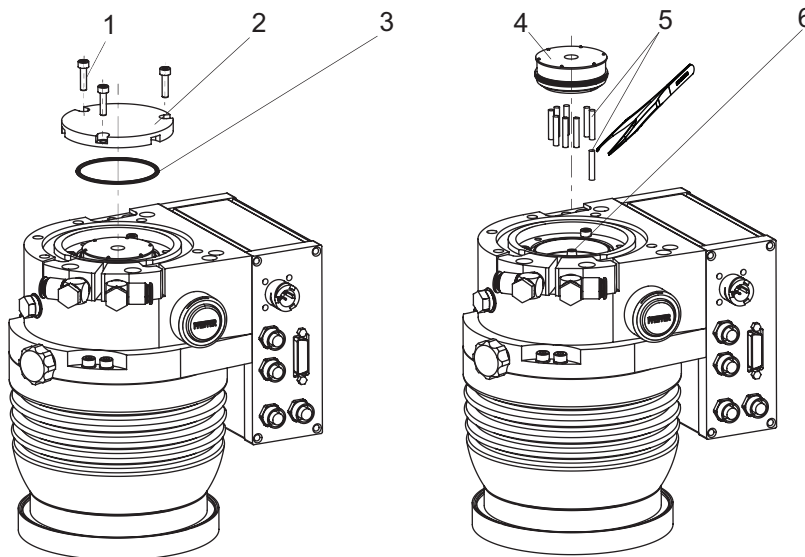

Fig. 22: Removing the operating fluid reservoir

- | | |
|--------------------|-----------------------------|
| 1 Allen head screw | 4 Operating fluid reservoir |
| 2 Screw cap | 5 Poroplast rods (9x) |
| 3 O-ring | 6 Injection tip |

Removing the operating fluid reservoir

1. Place the turbopump on the closed high vacuum flange.
2. Unscrew all Allen head screws from the screw cap on the pump base.
3. Remove the screw cap.
4. Remove the O-ring from the groove using a toothpick.
 - Avoid damage caused by scratches.
5. Remove the operating fluid reservoir from the bearing housing using the tweezers.
6. Pull the old Poroplast rods out of the pump base using tweezers.
7. Clean the screw cap with a clean, lint-free cloth.

- Do not use cleaning agents.

Installing the operating fluid reservoir

1. Insert all new Poroplast rods using tweezers.
2. Insert the operating fluid reservoir into the bearing housing with the felt side in the direction of the injection tip.
 - When doing so, do **not** exert pressure on the operating fluid reservoir.
3. Insert the O-ring in the groove in the pump base.
4. Fit the screw cap.
5. Tighten all 3 Allen head screws uniformly.
 - Tightening torque: **2.5 Nm**.

7.4 Replacing the electronic drive unit

The electronic drive unit of the turbopump cannot be repaired. In the event of a defect, replace the entire electronic drive unit with a replacement part.

NOTICE

Damage to the turbopump and electronic drive unit due to improper disconnection of components

Even after the mains power is switched off, the turbopump continues to deliver electrical energy during its run-down period. If the turbopump and electronic drive unit are disconnected prematurely, there is the risk of body contact and consequently the destruction of electronic components.

- ▶ Never disconnect the turbopump and electronic drive unit from each other if power is still connected or if the rotor is running.
- ▶ Monitor the turbopump rotation speed via the parameters available in the electronic drive unit (e.g., [P:398]).
- ▶ Wait until the turbopump comes to a standstill (rotation speed $f=0$).

NOTICE

Property damage from electrostatic discharge

Neglecting the electrostatic hazard for electronic components results in their damage or destruction

- ▶ Implement ESD safety measures at the workstation.
- ▶ Observe EN 61340 "Protection of electronic devices from electrostatic phenomena".



Backing up settings made by the customer

The factory operating parameters are always preset in replacement units. All settings made by the customer to the original electronic drive unit are lost when it is replaced. To preserve your custom settings, you have the following options:

1. Back up all your settings as a parameter set in an HPU.
2. Load a backup parameter set by means of HPU into the new electronic drive unit.
3. Program the individual settings into the new electronic drive unit by hand.
4. Note the operating instructions of the electronic drive unit and the HPU.

Preparatory work

1. Do not apply any mechanical loads to the electronic drive unit.
2. Switch off the turbopump (see chapter "Switching off", page 39).
3. Vent the vacuum system to atmospheric pressure (see chapter "Venting", page 40).
4. Interrupt the electric supply.
5. Remove all cables from the electronic drive unit.
6. **If dismantling the turbopump from the system:** Close all openings with the original protective covers and screw plugs.

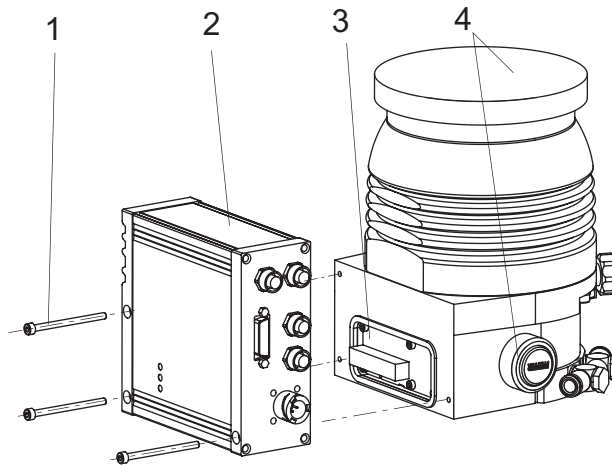

Fig. 23: Installing and removing the electronic drive unit TC 400

- | | |
|-------------------------|-----------------------------|
| 1 Allen head screw | 3 Adapter plate |
| 2 Electronic drive unit | 4 Original protective cover |

Required tools

- Allen key, size 3 mm
- Calibrated torque wrench (tightening factor ≤ 1.6)

Exchanging the electronic drive unit

1. Align the pump upright if required.
2. Unscrew all 3 Allen head screws from the electronic drive unit.
3. Remove the old electronic drive unit straight out from the pump.
4. Place a new electronic drive unit straight onto the adapter plate connection of the turbopump.
5. Screw the electronic drive unit to the turbopump with all 3 Allen head screws.
 - Tightening torque: **2.5 Nm**

7.5 Confirming the rotation speed specification

The typical nominal rotation speed of a turbopump is preset at the factory in the electronic drive unit. If the electronic drive unit is replaced or a different pump type is used, the reference set value of the nominal rotation speed is cleared. The manual confirmation of the nominal rotation speed is part of a redundant safety system as a measure for preventing excess rotation speed.

HiPace	Nominal rotation speed
10 30 60 80	1500 Hz
300	1000 Hz
450	1100 Hz
400 700 800	820 Hz

Tbl. 14: Characteristic nominal rotation speeds of the turbopumps

Required aids

- A connected Pfeiffer Vacuum display and control unit.
- Knowledge of the configuration and setting of electronic drive unit operating parameters.

Adjusting the nominal rotation speed confirmation

The redundant confirmation of the nominal rotation speed of a turbopump is possible by adjusting the **[P:777] NomSpdConf** parameter in the electronic drive unit.

1. Observe the display and control unit operating instructions.
2. See the electronic drive unit operating instructions.
3. Set the parameter **[P:794]** to "1" and activate the expanded parameter set.
4. Open and edit the parameter **[P:777]**.

5. Set the parameter **[P:777]** to the required value of the nominal rotation speed in Hertz.

Alternative: A Pfeiffer Vacuum SpeedConfigurator for the one-time immediate setting of parameter **[P:777]** is included with the replacement units.

8 Decommissioning

8.1 Shutting down for longer periods

WARNING

Health hazard through poisoning from toxic contaminated components or devices

Toxic process media result in contamination of devices or parts of them. During maintenance work, there is a risk to health from contact with these poisonous substances. Illegal disposal of toxic substances causes environmental damage.

- ▶ Take suitable safety precautions and prevent health hazards or environmental pollution by toxic process media.
- ▶ Decontaminate affected parts before carrying out maintenance work.
- ▶ Wear protective equipment.

Procedure for a longer downtime of the turbopump (> 1 year)

1. Remove the turbopump from the vacuum system if necessary.
2. Change the operating fluid reservoir of the turbopump if necessary.
3. Close the high vacuum flange of the turbopump.
4. Evacuate the turbopump via the fore-vacuum connection.
5. Vent the turbopump via the venting connection with dry, oil-free air or inert gas.
6. Close all flange openings with the original protective caps.
7. Store the turbopump upright with the high vacuum flange upwards.
8. Store the turbopump indoors only, within the specified temperature range.
9. In rooms with humid or aggressive atmospheres: Hermetically seal the turbopump together with a drying agent in a plastic bag.

8.2 Recommissioning

NOTICE

Risk of damage to the turbopump as a result of operating fluid aging after recommissioning

The shelf life of the operating fluid of the turbopump is limited. Aging of the operating fluid may lead to the failure of the ball bearing and cause damage to the turbopump.

- ▶ Pay attention to when the operating fluid must be changed:
 - after maximum 2 years without operation,
 - after maximum 4 years combined operation and downtimes.
- ▶ Observe the maintenance instructions and inform Pfeiffer Vacuum Service.

Procedures for recommissioning the turbopump

1. Check the turbopump for contamination and moisture.
2. Clean the turbopump externally with a lint-free cloth and a little isopropanol.
3. If necessary, arrange for Pfeiffer Vacuum Service to completely clean the turbopump.
4. Observe the total running time of the turbopump and if necessary, arrange for Pfeiffer Vacuum Service to replace the bearing.
5. Change the operating fluid reservoir of the turbopump.
6. Install the turbopump according to these operating instructions ([see chapter "Installation", page 20](#)).
7. Recommission the turbopump according to these instructions ([see chapter "Commissioning", page 36](#)).

8.3 Disposing of the vacuum pump

WARNING

Health hazard through poisoning from toxic contaminated components or devices

Toxic process media result in contamination of devices or parts of them. During maintenance work, there is a risk to health from contact with these poisonous substances. Illegal disposal of toxic substances causes environmental damage.

- ▶ Take suitable safety precautions and prevent health hazards or environmental pollution by toxic process media.
- ▶ Decontaminate affected parts before carrying out maintenance work.
- ▶ Wear protective equipment.

Procedure

- ▶ Dispose of all substances safely according to local regulations.

9 Malfunctions

Should malfunctions occur, you can find information about potential causes and how to fix them here. The operating manual of the associated electronic drive unit contains more detailed error descriptions.

Problem	Possible causes	Remedy
Pump will not start up; none of the built-in LEDs on the electronic drive unit illuminate	<ul style="list-style-type: none"> • Current supply interrupted 	<ol style="list-style-type: none"> 1. Check the plug contacts on the power supply pack. 2. Check the current supply lines. 3. Check the output voltage (24 or 48 V DC) at the power supply pack "DC out" connection.
	<ul style="list-style-type: none"> • Incorrect operating voltage 	<ol style="list-style-type: none"> 1. Observe the electronic drive unit rating plate. 2. Supply the correct operating voltage.
	<ul style="list-style-type: none"> • No operating voltage present 	<ol style="list-style-type: none"> 1. Supply the correct operating voltage. 2. Switch on the power supply pack.
	<ul style="list-style-type: none"> • Electronic drive unit defective 	<ol style="list-style-type: none"> 1. Replace the electronic drive unit. 2. Contact Pfeiffer Vacuum Service.
Pump will not start up; green LED on the electronic drive unit is flashing	<ul style="list-style-type: none"> • For operation without control unit: Pins 1-3 and 1-14 on the "remote" connection are not connected 	<ol style="list-style-type: none"> 1. Connect the connections according to the electronic drive unit connection diagram. 2. Check the bridges on the connection cable.
	<ul style="list-style-type: none"> • For operation via RS-485: The bridge between pins 1 and 14 inhibits control commands 	<ol style="list-style-type: none"> 1. Remove the bridge at the "remote" connection. 2. Check the connection cable.
	<ul style="list-style-type: none"> • For operation via RS-485: Parameters not set in the electronic drive unit 	<ol style="list-style-type: none"> 1. Set the parameters [P: 010] and [P: 023] via the interface RS-485 to 1 = "ON".
	<ul style="list-style-type: none"> • Voltage drop in the cable is too high 	<ol style="list-style-type: none"> 1. Check the connection cable. 2. Use a suitable connection cable.
Pump does not attain the nominal rotation speed within the set run-up time	<ul style="list-style-type: none"> • fore-vacuum pressure too high 	<ol style="list-style-type: none"> 1. Check backup pump compatibility (see technical data). 2. Check that the backup pump is working.
	<ul style="list-style-type: none"> • Pump leakage 	<ol style="list-style-type: none"> 1. Carry out leak detection. 2. Check seals and flange connections. 3. Eliminate leaks.
	<ul style="list-style-type: none"> • Gas throughput too high 	<ol style="list-style-type: none"> 1. Reduce the process gas load.
	<ul style="list-style-type: none"> • Rotor not running smoothly, defective bearing 	<ol style="list-style-type: none"> 1. Check the pump for noise development 2. Contact Pfeiffer Vacuum Service.
	<ul style="list-style-type: none"> • Run-up time setpoint adjusted too low 	<ol style="list-style-type: none"> 1. Extend the run-up time setpoint [P:700] via a display and control unit.
	Thermal load due to: <ul style="list-style-type: none"> • lack of ventilation • water flow too low • fore-vacuum pressure too high • ambient temperature too high 	<ol style="list-style-type: none"> 1. Reduce the thermal load. <ul style="list-style-type: none"> – Ensure adequate air supply. – Adjust the cooling water flow. – Reduce the fore-vacuum pressure. – Adapt the ambient conditions.

Pump not achieving the ultimate pressure	<ul style="list-style-type: none"> • Pump is dirty 	<ol style="list-style-type: none"> 1. Heat the pump if required. 2. Have it cleaned. 3. Contact Pfeiffer Vacuum Service.
	<ul style="list-style-type: none"> • Vacuum chamber, pipes or pump leaky 	<ol style="list-style-type: none"> 1. Carry out leak detection starting from the vacuum chamber. 2. Check seals and flange connections. 3. Eliminate leaks in the vacuum system.
Unusual noises during operation	<ul style="list-style-type: none"> • Rotor bearing damaged 	<ol style="list-style-type: none"> 1. Contact Pfeiffer Vacuum Service.
	<ul style="list-style-type: none"> • Rotor damaged 	<ol style="list-style-type: none"> 1. Contact Pfeiffer Vacuum Service.
	<ul style="list-style-type: none"> • Splinter shield or protective screen loose 	<ol style="list-style-type: none"> 1. Check and correct the seat of the splinter shield or protective screen in the high vacuum flange. 2. Follow the installation instructions.
Red LED on the electronic drive unit illuminates	<ul style="list-style-type: none"> • Group error 	<ol style="list-style-type: none"> 1. Reset the malfunction by switching the current supply off and on. 2. Reset the malfunction with V+ on pin 13 on the "remote" connection. 3. Set the parameter [P: 009] via the interface RS-485 to 1 = Malfunction acknowledgment. 4. Set the parameter [P: Set parameter [P:010] via the interface RS-485 to 0 = off and then 1 = On and Malfunction acknowledgment. 5. Carry out a differentiated malfunction analysis with a display and control unit. 6. Contact Pfeiffer Vacuum Service.

Tbl. 15: Troubleshooting turbopumps

10 Service solutions from Pfeiffer Vacuum

We offer first class service

Long vacuum component service life, coupled with low downtimes, are clear expectations that you have of us. We satisfy your needs with capable products and outstanding service.

We are consistently striving to perfect our core competence, service for vacuum components. And our service is far from over once you've purchased a product from Pfeiffer Vacuum. It often enough really just begins then. In proven Pfeiffer Vacuum quality, of course.

Our professional sales engineers and service technicians stand ready to provide hands-on support to you worldwide. Pfeiffer Vacuum offers a complete portfolio of service offerings, ranging from genuine spare parts right through to service agreements.

Take advantage of Pfeiffer Vacuum Service

Whether for preventative on-site service from our field service, fast replacement with as-new replacement products or repair in a Service Center close to you; you have various options for upholding your equipment availability. Detailed information and addresses can be found on our website in the Pfeiffer Vacuum Service section.

Advice on the optimum solution is available from your Pfeiffer Vacuum contact partner.

For quick and smooth handling of the service process, we recommend the following steps:



1. Download the current form templates.
 - [Declaration of Service Request](#)
 - [Service Request](#)
 - [Declaration of Contamination](#)

- a. Dismantle all accessories and keep them (all external mounted parts as valve, inlet screen, etc.).
- b. Drain the operating fluid/lubricant as necessary.
- c. Drain the cooling medium as necessary.



2. Fill out the service request and the declaration of contamination.



3. Send the forms via email, fax or post to your local Service Center.

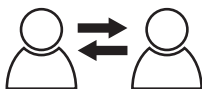

4. You will receive a response from Pfeiffer Vacuum.

PFEIFFER VACUUM

Sending of contaminated products

No units will be accepted if they are contaminated with micro-biological, explosive or radioactive substances. If products are contaminated or if the declaration of contamination is missing, Pfeiffer Vacuum will contact the customer before starting maintenance. In addition, depending on the product and the level of contamination **additional decontamination costs** may be required.

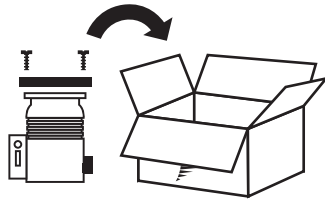

5. Prepare the product for transport in accordance with the details in the declaration of contamination.
 - a) Neutralize the product with nitrogen or dry air.
 - b) Close all openings with airtight blank flanges.
 - c) Seal the product in appropriate protective film.
 - d) Only pack the product in suitable, stable transport containers.
 - e) Observe the applicable transport conditions.

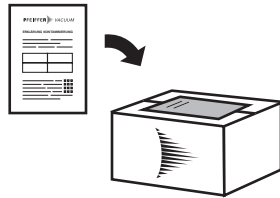

6. Affix the declaration of contamination to the **outside** of the packaging.

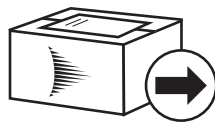

7. Then send your product to your local Service Center.

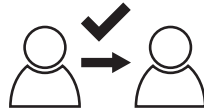

8. You will receive a confirmation message/a quotation from Pfeiffer Vacuum.

PFEIFFER VACUUM

For all service orders, our General Terms and Conditions of Sales and Supply and General Terms and Conditions of Repair and Maintenance apply to vacuum equipment and components.

11 Spare parts HiPace 300 P

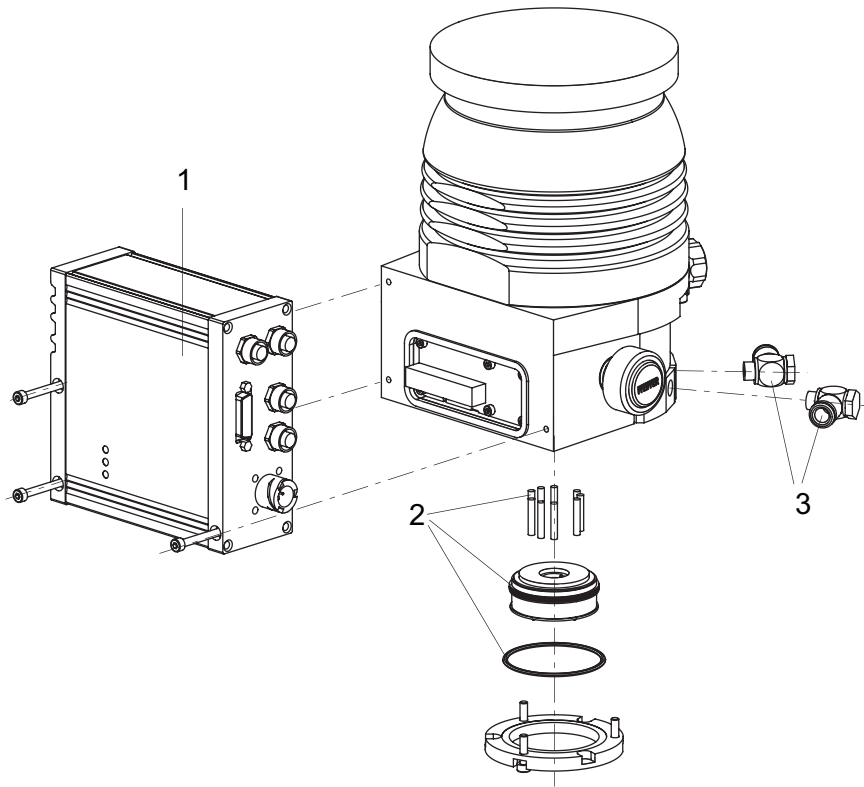

Fig. 24: Spare parts HiPace 300 P

Position	Designation	Size	Order number	Note	Pieces	Quantity
1	Electronic drive unit TC 400		refer to the rating plate	depending on the connection panel	1	
2	Operating fluid reservoir		PM 203 410 -T	incl. Poroplast rods and O-ring	1	
3	Banjo fitting		P 4131 007 D	Water cooling	2	

Tbl. 16: Overview of the spare parts available for the HiPace 300 P

12 Accessories



View the line of accessories for Pfeiffer Vacuum turbopumps online at pfeiffer-vacuum.com.

13 Technical data and dimensions

13.1 General

This section describes the basis for the technical data of Pfeiffer Vacuum turbopumps.



Technical data

Maximum values refer exclusively to the input as a single load.

- Specifications according to PNEUROP committee PN5
- ISO 27892 2010: "Vacuum technology - Turbomolecular pumps - Measurement of rapid shutdown torque"
- ISO 21360 2012: "Vacuum technology - Standard methods for measuring vacuum-pump performance - Part 1: General description"
- ISO 21360 2018: "Vacuum technology - Standard methods for measuring vacuum-pump performance - Part 4: Turbomolecular vacuum pumps"
- Ultimate pressure with test dome after 48 h bake out duration
- Gas throughput with water cooling; backing pump = rotary vane pump (10 m³/h)
- Cooling water consumption at maximum gas throughput, cooling water temperature 25 °C
- Integral leakage rate with 100 % helium concentration, 10 s measurement duration
- Sound pressure level at distance to vacuum pump = 1 m

	mbar	bar	Pa	hPa	kPa	Torr mm Hg
mbar	1	1 · 10 ⁻³	100	1	0.1	0.75
bar	1000	1	1 · 10 ⁵	1000	100	750
Pa	0.01	1 · 10 ⁻⁵	1	0.01	1 · 10 ⁻³	7.5 · 10 ⁻³
hPa	1	1 · 10 ⁻³	100	1	0.1	0.75
kPa	10	0.01	1000	10	1	7.5
Torr mm Hg	1.33	1.33 · 10 ⁻³	133.32	1.33	0.133	1

1 Pa = 1 N/m²

Tbl. 17: Conversion table: Pressure units

	mbar l/s	Pa m³/s	sccm	Torr l/s	atm cm³/s
mbar l/s	1	0.1	59.2	0.75	0.987
Pa m³/s	10	1	592	7.5	9.87
sccm	1.69 · 10 ⁻²	1.69 · 10 ⁻³	1	1.27 · 10 ⁻²	1.67 · 10 ⁻²
Torr l/s	1.33	0.133	78.9	1	1.32
atm cm³/s	1.01	0.101	59.8	0.76	1

Tbl. 18: Conversion table: Units for gas throughput

13.2 Technical data

Classification	HiPace® 300 P	HiPace® 300 P	HiPace® 300 P
Order number	PM P04 710	PM P04 711	PM P04 712
Electronic drive unit	with TC 400	with TC 400	with TC 400
Flange (in)	DN 100 ISO-K	DN 100 CF-F	DN 100 ISO-F

Classification	HiPace® 300 P	HiPace® 300 P	HiPace® 300 P
Flange (out)	DN 16 ISO-KF/G ¼"	DN 16 ISO-KF/ G ¼"	DN 16 ISO-KF/ G ¼"
Ultimate pressure according to PNEUROP	$< 1 \cdot 10^{-7}$ hPa	$< 1 \cdot 10^{-8}$ hPa	$< 1 \cdot 10^{-7}$ hPa
Compression ratio for Ar	$> 1 \cdot 10^7$	$> 1 \cdot 10^7$	$> 1 \cdot 10^7$
Compression ratio for H ₂	$3 \cdot 10^2$	$3 \cdot 10^2$	$3 \cdot 10^2$
Compression ratio for He	$2.2 \cdot 10^3$	$2.2 \cdot 10^3$	$2.2 \cdot 10^3$
Compression ratio for N ₂	$> 1 \cdot 10^6$	$> 1 \cdot 10^6$	$> 1 \cdot 10^6$
Pumping speed for Ar	250 l/s	250 l/s	250 l/s
Pumping speed for H ₂	125 l/s	125 l/s	125 l/s
Pumping speed for He	220 l/s	220 l/s	220 l/s
Pumping speed for N ₂	245 l/s	245 l/s	245 l/s
Gas throughput at full rotational speed for Ar	4.4 hPa·l/s	4.4 hPa·l/s	4.4 hPa·l/s
Gas throughput at full rotational speed for H ₂	> 50 hPa·l/s	> 50 hPa·l/s	> 50 hPa·l/s
Gas throughput at full rotational speed for He	> 20 hPa·l/s	> 20 hPa·l/s	> 20 hPa·l/s
Gas throughput at full rotational speed for N ₂	17 hPa·l/s	17 hPa·l/s	17 hPa·l/s
Fore-vacuum max. for N ₂	1 hPa	1 hPa	1 hPa
Fore-vacuum max. for Ar	1.8 hPa	1.8 hPa	1.8 hPa
Fore-vacuum max. for H ₂	0.09 hPa	0.09 hPa	0.09 hPa
Fore-vacuum max. for He	0.45 hPa	0.45 hPa	0.45 hPa
Rotation speed ± 2 %	60000 rpm	60000 rpm	60000 rpm
Power characteristic line in gas mode 0, vertex C	137/60000 W/min ⁻¹	137/60000 W/min ⁻¹	137/60000 W/min ⁻¹
Power characteristic line in gas mode 0, vertex D	180/49980 W/min ⁻¹	180/49980 W/min ⁻¹	180/49980 W/min ⁻¹
Power characteristic line in gas mode 1, vertex A	201/60000 W/min ⁻¹	201/60000 W/min ⁻¹	201/60000 W/min ⁻¹
Power characteristic line in gas mode 1, vertex B	221/49980 W/min ⁻¹	221/49980 W/min ⁻¹	221/49980 W/min ⁻¹
Power characteristic line in gas mode 2, vertex E	201/60000 W/min ⁻¹	201/60000 W/min ⁻¹	201/60000 W/min ⁻¹
Power characteristic line in gas mode 2, vertex F	221/49980 W/min ⁻¹	221/49980 W/min ⁻¹	221/49980 W/min ⁻¹
Betriebsspannung: DC	24 V	24 V	24 V
Input voltage: tolerance	± 5 %	± 5 %	± 5 %
Current consumption max.	12.5 A	12.5 A	12.5 A
Operating voltage power supply	90 – 265 V AC	90 – 265 V AC	90 – 265 V AC
Power consumption max.	300 W	300 W	300 W
Run-up time	1.2 min	1.2 min	1.2 min
Interfaces	RS-485, Remote	RS-485, Remote	RS-485, Remote
Cooling method, standard	Water	Water	Water
Cooling method, optional	Air	Air	Air

Classification	HiPace® 300 P	HiPace® 300 P	HiPace® 300 P
Permissible irradiated thermal power max.	2.4 W	2.4 W	2.4 W
Permissible magnetic field max.	5.5 mT	5.5 mT	5.5 mT
Protection category	IP54	IP54	IP54
Cooling water consumption	50 l/h	50 l/h	50 l/h
Cooling water temperature	15 – 35 °C	15 – 35 °C	15 – 35 °C
Sound pressure level	≤ 50 dB(A)	≤ 50 dB(A)	≤ 50 dB(A)
Venting connection	G 1/8"	G 1/8"	G 1/8"
Connection pressure (abs.) for venting/sealing gas valve	1500 hPa	1500 hPa	1500 hPa
Integral leak rate	$< 1 \cdot 10^{-8}$ Pa m ³ /s	$< 1 \cdot 10^{-8}$ Pa m ³ /s	$< 1 \cdot 10^{-8}$ Pa m ³ /s
Relative humidity of air	5 – 85 %, not condensing	5 – 85 %, not condensing	5 – 85 %, not condensing
Shipping and storage temperature	-25 °C – 55 °C	-25 °C – 55 °C	-25 °C – 55 °C
Mounting orientation	Any	Any	Any
Bearing	Hybrid	Hybrid	Hybrid
Weight	6.4 kg	8.4 kg	6.7 kg

Tbl. 19: Technical data for HiPace 300 P | 24 V

Classification	HiPace® 300 P	HiPace® 300 P	HiPace® 300 P
Order number	PM P04 720	PM P04 721	PM P04 722
Electronic drive unit	with TC 400	with TC 400	with TC 400
Flange (in)	DN 100 ISO-K	DN 100 CF-F	DN 100 ISO-F
Flange (out)	DN 16 ISO-KF/G ¼"	DN 16 ISO-KF/G ¼"	DN 16 ISO-KF/G ¼"
Ultimate pressure according to PNEUROP	$1 \cdot 10^{-7}$ hPa	$1 \cdot 10^{-8}$ hPa	$1 \cdot 10^{-7}$ hPa
Compression ratio for Ar	$1 \cdot 10^7$	$1 \cdot 10^7$	$1 \cdot 10^7$
Compression ratio for H ₂	$3 \cdot 10^2$	$3 \cdot 10^2$	$3 \cdot 10^2$
Compression ratio for He	$2.2 \cdot 10^3$	$2.2 \cdot 10^3$	$2.2 \cdot 10^3$
Compression ratio for N ₂	$1 \cdot 10^6$	$1 \cdot 10^6$	$1 \cdot 10^6$
Pumping speed for Ar	250 l/s	250 l/s	250 l/s
Pumping speed for H ₂	125 l/s	125 l/s	125 l/s
Pumping speed for He	220 l/s	220 l/s	220 l/s
Pumping speed for N ₂	245 l/s	245 l/s	245 l/s
Gas throughput at full rotational speed for Ar	4.4 hPa·l/s	4.4 hPa·l/s	4.4 hPa·l/s
Gas throughput at full rotational speed for H ₂	50 hPa·l/s	50 hPa·l/s	50 hPa·l/s
Gas throughput at full rotational speed for He	20 hPa·l/s	20 hPa·l/s	20 hPa·l/s
Gas throughput at full rotational speed for N ₂	17 hPa·l/s	17 hPa·l/s	17 hPa·l/s
Fore-vacuum max. for N ₂	1 hPa	1 hPa	1 hPa

Classification	HiPace® 300 P	HiPace® 300 P	HiPace® 300 P
Fore-vacuum max. for Ar	1.8 hPa	1.8 hPa	1.8 hPa
Fore-vacuum max. for H ₂	0.09 hPa	0.09 hPa	0.09 hPa
Fore-vacuum max. for He	0.45 hPa	0.45 hPa	0.45 hPa
Rotation speed ± 2 %	60000 rpm	60000 rpm	60000 rpm
Power characteristic line in gas mode 0, vertex C	137/60000 W/min ⁻¹	137/60000 W/min ⁻¹	137/60000 W/min ⁻¹
Power characteristic line in gas mode 0, vertex D	180/49980 W/min ⁻¹	180/49980 W/min ⁻¹	180/49980 W/min ⁻¹
Power characteristic line in gas mode 1, vertex A	201/60000 W/min ⁻¹	201/60000 W/min ⁻¹	201/60000 W/min ⁻¹
Power characteristic line in gas mode 1, vertex B	221/49980 W/min ⁻¹	221/49980 W/min ⁻¹	221/49980 W/min ⁻¹
Power characteristic line in gas mode 2, vertex E	201/60000 W/min ⁻¹	201/60000 W/min ⁻¹	201/60000 W/min ⁻¹
Power characteristic line in gas mode 2, vertex F	221/49980 W/min ⁻¹	221/49980 W/min ⁻¹	221/49980 W/min ⁻¹
Betriebsspannung: DC	48 V	48 V	48 V
Input voltage: tolerance	±5 %	±5 %	±5 %
Current consumption max.	8.4 A	8.4 A	8.4 A
Operating voltage power supply	90 – 265 V AC	90 – 265 V AC	90 – 265 V AC
Power consumption max.	400 W	400 W	400 W
Run-up time	45 s	45 s	45 s
Interfaces	RS-485, Remote	RS-485, Remote	RS-485, Remote
Cooling method, standard	Water	Water	Water
Cooling method, optional	Air	Air	Air
Permissible irradiated thermal power max.	2.4 W	2.4 W	2.4 W
Permissible magnetic field max.	5.5 mT	5.5 mT	5.5 mT
Protection category	IP54	IP54	IP54
Cooling water consumption	50 l/h	50 l/h	50 l/h
Cooling water temperature	15 – 35 °C	15 – 35 °C	15 – 35 °C
Sound pressure level	50 dB(A)	50 dB(A)	50 dB(A)
Venting connection	G 1/8"	G 1/8"	G 1/8"
Connection pressure (abs.) for venting/sealing gas valve	1500 hPa	1500 hPa	1500 hPa
Integral leak rate	1 · 10 ⁻⁸ Pa m ³ /s	1 · 10 ⁻⁸ Pa m ³ /s	1 · 10 ⁻⁸ Pa m ³ /s
Relative humidity of air	5 – 85 %, not condensing	5 – 85 %, not condensing	5 – 85 %, not condensing
Shipping and storage temperature	-25 °C – 55 °C	-25 °C – 55 °C	-25 °C – 55 °C
Mounting orientation	Any	Any	Any
Bearing	Hybrid	Hybrid	Hybrid
Weight	6.4 kg	8.4 kg	6.7 kg

Tbl. 20: Technical data for HiPace 300 P | 48 V

13.3 Dimensions

Dimensions in mm

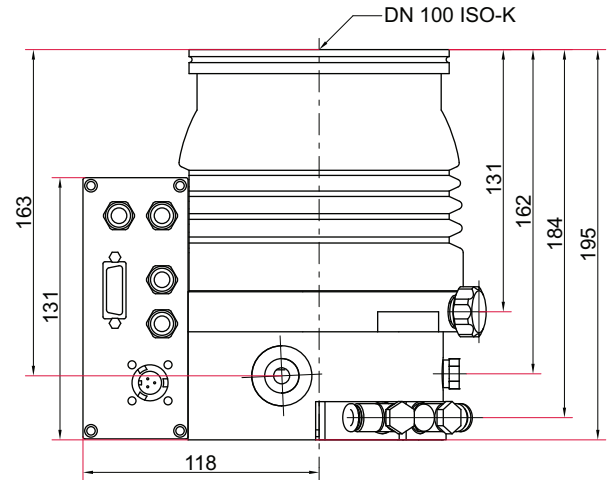
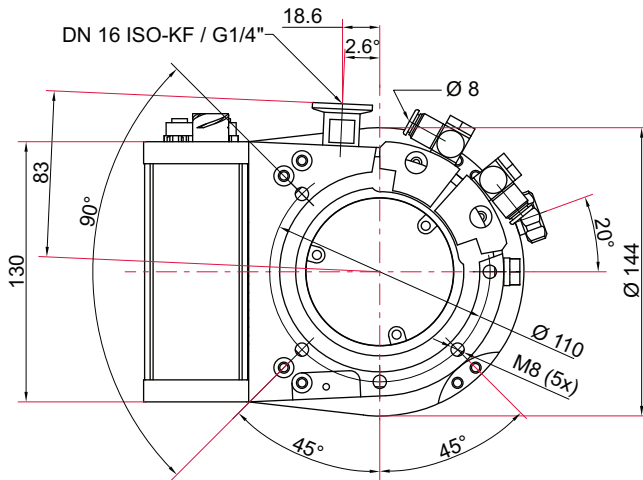

Fig. 25: HiPace 300 | TC 400 | DN 100 ISO-K

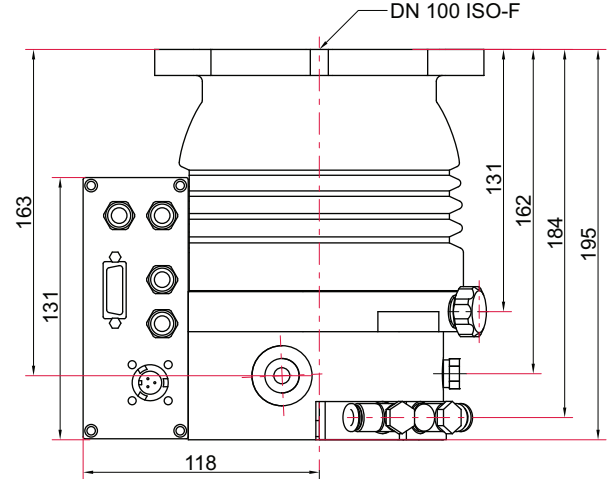
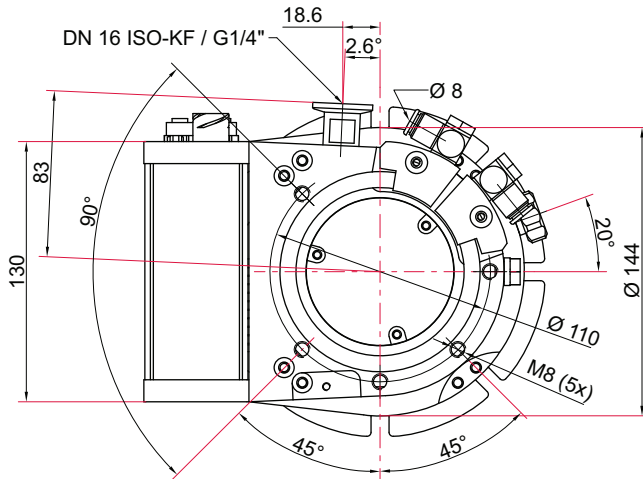

Fig. 26: HiPace 300 | TC 400 | DN 100 ISO-F

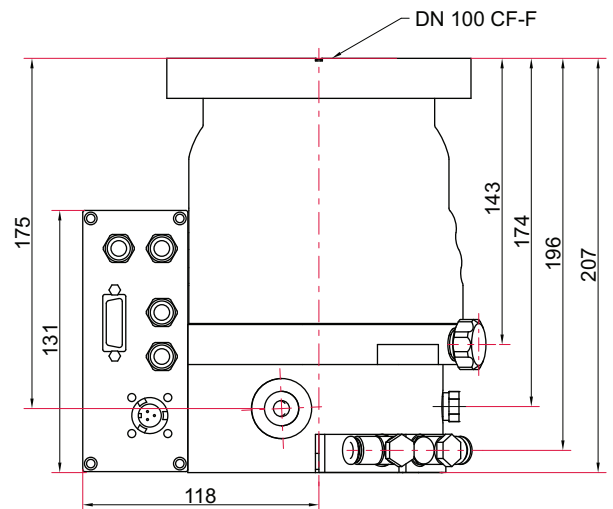
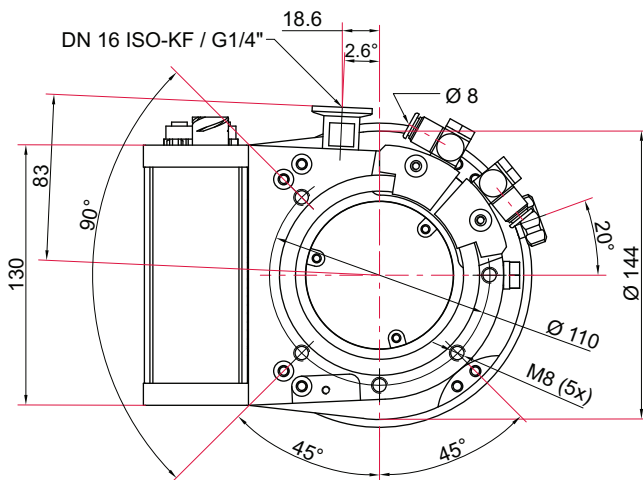

Fig. 27: HiPace 300 | TC 400 | DN 100 CF-F



Declaration of conformity

We hereby declare that the product cited below satisfies all relevant provisions of the following **EU Directives**:

- **Machinery 2006/42/EC (Annex II, no. 1 A)**
- **Electromagnetic compatibility 2014/30/EU**
- **Restriction of the use of certain hazardous substances 2011/65/EU**

The authorized representative for the compilation of technical documents is Mr. Helmut Bernhardt, Pfeiffer Vacuum GmbH, Berliner Straße 43, 35614 Aßlar, Germany.

Turbopump

HiPace 300 P

Harmonized standards and national standards and specifications which have been applied:

DIN EN ISO 12100:2011

DIN EN 1012-2:2011

DIN EN 61000-3-2:2014

DIN EN 61000-3-3:2014

DIN EN 61010-1:2010

DIN EN 61326-1:2013

DIN EN 62061:2013

Signature:

Pfeiffer Vacuum GmbH
Berliner Straße 43
35614 Aßlar
Germany

(Dr. Ulrich von Hülsen)
Managing Director

Aßlar, 2018-11-09

VACUUM SOLUTIONS FROM A SINGLE SOURCE

Pfeiffer Vacuum stands for innovative and custom vacuum solutions worldwide, technological perfection, competent advice and reliable service.

COMPLETE RANGE OF PRODUCTS

From a single component to complex systems:

We are the only supplier of vacuum technology that provides a complete product portfolio.

COMPETENCE IN THEORY AND PRACTICE

Benefit from our know-how and our portfolio of training opportunities!

We support you with your plant layout and provide first-class on-site service worldwide.

ed. A - Date 1812 - P/N:PT0633BEN



Are you looking for a
perfect vacuum solution?
Please contact us

Pfeiffer Vacuum GmbH
Headquarters • Germany
T +49 6441 802-0
info@pfeiffer-vacuum.de

www.pfeiffer-vacuum.com

PFEIFFER  **VACUUM**