



OPERATING INSTRUCTIONS

EN

Translation of the original instructions

HICUBE PRO

Turbo pumping station

PFEIFFER  **VACUUM**

Table of contents

1	About this manual	4
1.1	Validity	4
1.1.1	Applicable documents	4
1.2	Conventions	4
1.2.1	Safety instructions	4
1.2.2	Pictographs	5
1.2.3	Instructions in the text	5
1.2.4	Abbreviations	5
1.2.5	Symbols used	5
2	Safety	6
2.1	Safety precautions	6
2.2	Protective equipment	7
2.3	Proper use	7
2.4	Improper use	8
3	Transport and storage	9
3.1	Transport	9
3.1.1	Transportation lock	9
3.2	Storage	9
4	Product description	10
4.1	Product identification	11
4.1.1	Product characteristics	11
4.1.2	Scope of delivery	11
4.2	Function	11
4.2.1	Control	11
4.2.2	Cooling	12
4.3	Range of application	12
5	Installation	13
5.1	Preparatory work	13
5.2	Set-up	13
5.2.1	Earthing	13
5.2.2	Anchoring the pumping station	14
5.3	Connecting the high vacuum side	14
5.4	Connecting the exhaust side	15
5.5	Connecting an external turbopump	15
5.5.1	Connecting the high vacuum side	15
5.5.2	Connecting the fore-vacuum side	15
5.6	Transportation lock	16
5.7	Filling up the operating fluid	16
5.8	Connecting accessories	17
5.8.1	Connecting a measuring device	17
5.9	Connecting to the mains power supply	18
6	Operation	19
6.1	Commissioning	19
6.2	Operation modes	19
6.3	Function description	20
6.3.1	Operation with DCU	20
6.3.2	Saving energy	20
6.4	Operation with gas ballast valve	21
6.5	Operation with fore-vacuum valve	22
6.6	Switching off and venting	22

6.6.1	Switching off	22
6.6.2	Venting	22
7	Maintenance / replacement	23
7.1	Maintenance intervals and responsibilities	23
7.2	Removal of components for their maintenance	23
7.2.1	Preparatory work	24
7.2.2	Dismantling of the turbopump	24
7.2.3	Installing the turbopump	25
7.3	Changing the operating fluid	26
8	Decommissioning	27
8.1	Shutting down for longer periods	27
8.2	Re-starting	27
8.3	Disposal	27
9	Malfunctions	28
9.1	Rectifying malfunctions	28
10	Service	29
11	Spare parts HiCube Pro	30
12	Accessories	30
13	Technical data	31
13.1	General	31
13.2	HiCube 80 Pro	32
13.2.1	DN 40 ISO-KF	32
13.2.2	DN 63 ISO-K	32
13.2.3	DN 63 CF-F	32
13.3	HiCube 300 Pro	33
13.3.1	DN 100 ISO-K	33
13.3.2	DN 100 CF-F	33
13.4	HiCube 400 Pro	34
13.4.1	DN 100 ISO-K	34
13.4.2	DN 100 CF-F	34
13.5	HiCube 700 Pro	35
13.5.1	DN 160 ISO-K	35
13.5.2	DN 160 CF-F	35
14	Dimensions	36
	Declaration of conformity	37

1 About this manual

1.1 Validity

This operating manual is for customers of Pfeiffer Vacuum. It describes the functioning of the designated product and provides the most important information for safe use of the unit. The description follows applicable EU guidelines. All information provided in this operating manual refers to the current state of the product's development. The documentation remains valid as long as the customer does not make any changes to the product.

Up-to-date operating instructions can also be downloaded from www.pfeiffer-vacuum.com.

1.1.1 Applicable documents

HiCube Pro	Operating instructions
Declaration of Conformity	Part of this document
Operating instructions for components	see product description*

*also available via www.pfeiffer-vacuum.com

1.2 Conventions

1.2.1 Safety instructions

The safety instructions in Pfeiffer Vacuum operating instructions are the result of risk evaluations and hazard analyses and are oriented on international certification standards as specified by UL, CSA, ANSI Z-535, SEMI S1, ISO 3864 and DIN 4844. In this document, the following hazard levels and information are considered:

DANGER
Imminent danger Indicates an imminent hazardous situation that will result in death or serious injury.
WARNING
Possibly imminent danger Indicates an imminent hazardous situation that can result in death or serious injury.
CAUTION
Possibly imminent danger Indicates an imminent hazardous situation that can result in minor or moderate injury.
NOTICE
Command or note Command to perform an action or information about properties, the disregarding of which may result in damage to the product.

1.2.2 Pictographs



Prohibition of an action or activity in connection with a source of danger, the disregarding of which may result in serious accidents



Warning of a displayed source of danger in connection with operation of the unit or equipment



Command to perform an action or task associated with a source of danger, the disregarding of which may result in serious accidents



Important information about the product or this document

1.2.3 Instructions in the text

→ Work instruction: here you have to do something.

1.2.4 Abbreviations

DCU:	Display Control Unit
HPU:	Handheld Programming Unit
TC:	Electronic drive unit for turbopump
TPS:	Mains pack

1.2.5 Symbols used

The following symbols are used consistently throughout the diagrams:

- ⊕ High vacuum flange
- ∇ Fore-vacuum connection
- ⚡ Electric connection
- ⊕ Air cooling unit
- Ⓢ Venting connection
- Ⓢ Sealing gas connection
- △ Exhaust connection

2 Safety

2.1 Safety precautions



Duty to inform

Each person involved in the installation, operation or maintenance of the pumping station must read and observe the safety-related parts of these operating instructions and the components instructions.

→ The operator is obligated to make operating personnel aware of dangers originating from the vacuum pump, the pumped medium or the entire system.



NOTICE

Checking the safety system against excess rotation speed

To provide the functioning of the integrated safety system for avoiding excess rotation speed, the pump must run-up from the standstill at least once a year.

→ Switch off the pump and await the complete standstill (rotation speed = 0 Hz).

→ Run-up the pump according to this operating instructions.



WARNING

Danger of unsafe electrical installation

Safe operation after installation is the responsibility of the operator.

→ Do not independently modify or change the pump and electrical equipment.

→ Make sure that the system is integrated in an emergency off safety circuit.

→ Consult Pfeiffer Vacuum for special requirements.



WARNING

Danger of electric shock

In case of defect, the parts connected to the mains supply are under voltage.

→ Always keep the mains connection freely accessible so you can disconnect it at any time.



WARNING

Danger of electric shock

The pumping station is only free of voltages when the mains plug has been disconnected.

→ Switch off the master switch and disconnect the mains plug before all work.

→ Secure against unintentional restarting.



- Do not expose any body parts to the vacuum.
- Observe all safety and accident prevention regulations.
- Regularly check the proper observance of all safety measures.
- Always ensure a safe connection to the protective earthing conductor (PE, protection class I).
- Do not loosen any plug connection during operations.
- Wait for the rotor to reach standstill before performing work on the high vacuum flange.
- Keep leads and cables well away from hot surfaces (> 70 °C).
- Never fill or operate turbopump with cleaning agent.
- Do not operate the turbopump with open high vacuum flange.
- Do not carry out any unauthorised modifications or conversions to the pumps.
- The unit has been accredited with protection class IP 20. Take necessary measures when installing into ambient conditions, which afford other protection classes.

2.2 Protective equipment

Determined situations concerning the handling of vacuum pumps require wearing of personal protective equipment. The owner, respectively the employer are obligated to provide an adequate equipment to any operating persons.



DANGER

Danger to health by hazardous substances during maintenance or installation

Depending on the process vacuum pumps, components or operating fluids can be contaminated by toxic, reactive or radioactive substances.

→ Wear adequate protective equipment during maintenance and repairs or in case of reinstallation.

WARNING

Risk of injury through falling objects

When transporting vacuum pumps by hand, there is a danger through loads slipping and falling down.

- Carry small and mid-size vacuum pumps two-handed.
- Carry vacuum pumps > 20 kg by a suitable lifting device.
- Wear safety shoes with steel toe cap according to directive EN 347.

CAUTION

Risk of injury through hot surfaces

Vacuum pumps can become hot during operation.

- Allow the pump to cool before maintenance and repairs.
- If necessary wear protective gloves according to EN 420.

CAUTION

Risk of injury through sharp edges

Rotor and stator disks of turbopumps have very sharp edges.

- Before any working wait for the complete standstill of the pump.
- Do not reach in the high vacuum flange.
- If necessary wear protective gloves according to EN 420.

2.3 Proper use



NOTICE

EC conformity

The manufacturer's declaration of conformity becomes invalid if the operator modifies the original product or installs additional components.

→ Following installation into a plant and before commissioning, the operator must check the entire system for compliance with the valid EU directives and reassess it accordingly.

- Only use the pumping station for creating vacuum.
- Only operate the pumping station as an entire unit.
- Only use the pumping station for evacuation of dry and inert gases; other applications only after consultation with Pfeiffer Vacuum.

2.4 Improper use

Improper use will cause all claims for liability and warranties to be forfeited. Improper use is defined as usage for purposes deviating from those mentioned above, especially:

- pumping of corrosive or explosive media
- pumping of condensing vapors
- pumping of liquids
- pumping of dusts
- operation with improper high gas throughput
- operation with improper high fore-vacuum pressures
- operation with improper high levels of insulated heat input
- operation in improper high magnetic fields
- operation with improper gas mode
- venting with improper high venting rates
- use of the vacuum pump to generate pressure
- operation of the devices in areas with ionizing radiation
- operation in potentially explosive areas
- use of the devices in systems in which impact-like stress and vibrations or periodic forces affect the devices
- use of accessories or spare parts, which are not named in this manual



Closure seal

The product is sealed at the factory. Damaging or removal of a closure seal leads to the loss of liability and warranty entitlements.

→ Do not open the product within its warranty period!

→ For process-related shorter maintenance intervals please contact the Pfeiffer Vacuum Service.

3 Transport and storage

3.1 Transport



WARNING

Danger from falling and swinging loads!

When lifting the pumping station there is a danger of falling parts.

- Only fix a lifting device for transport on all provided points of the frame of the pumping station (first remove the rubber caps).
- Make sure that there are no persons under the suspended load.
- Do not lift the pumping station on the handle.



CAUTION

Risk of injury due to the pumping station's tipping or rolling away

Superstructural parts provided by customer can shift the pumping station's center of gravity, creating a risk of tipping. On inclined planes, there are general risks of tipping and injury due to squeezing from rolling pumping stations.

- Do not transport or move pumping stations with superstructural parts.
- Do not transport or position a pumping station on inclined planes with a downgrade $> 5^\circ$ (approx. 8.7%).

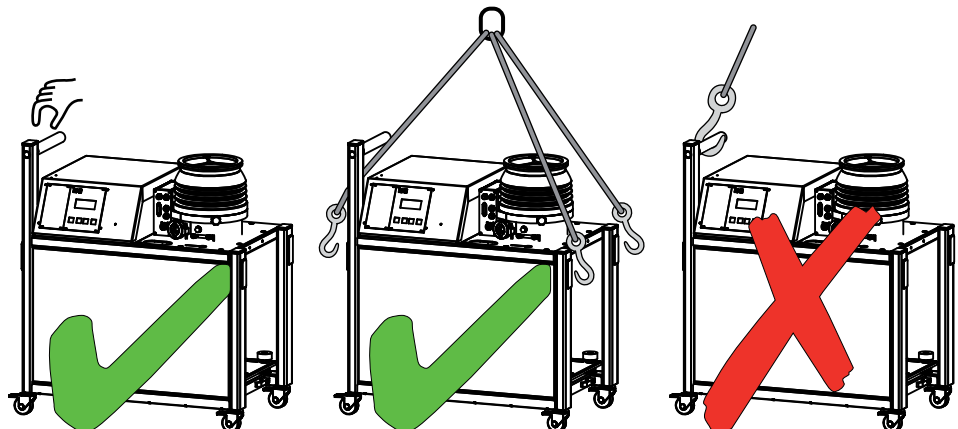

- Always transport the pumping station uprightly and as even as possible.
- Keep the original protective covers.

3.1.1 Transportation lock

The backing pump of the pumping station HiCube Pro is secured against damage during transport .

- Follow instructions concerning the installation location!
- Before putting into operation loosen the backing pump's transportation lock device at the installation location.

3.2 Storage

- Close the flange openings by using the original protective covers.
- Close further connection ports by using the corresponding protective covers.
- Only store the pumping station indoors at an ambient temperature between -10°C and $+40^\circ\text{C}$.
- In rooms with moist or aggressive atmospheres, the pumping station must be airtight shrink-wrapped in a plastic bag together with a bag of dessicant.

4 Product description

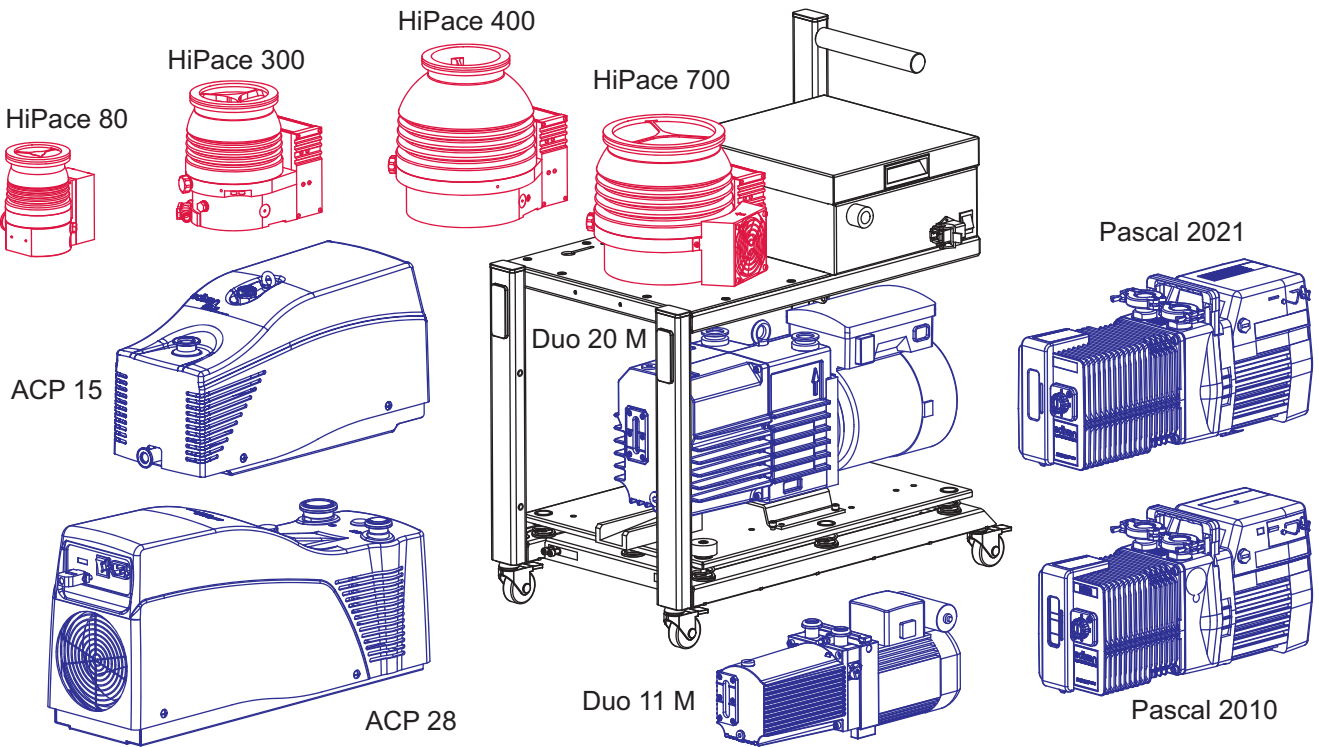

Feature	HiCube Pro				Operating instructions
	DN 40 / DN 63	DN 100		DN 160	
Turbopump	HiPace 80	HiPace 300	HiPace 400	HiPace 700	PT 0208 BN PT 0200 BN PT 0210 BN PT 0209 BN
Electronic drive unit	TC 110	TC 110 TC 400	TC 400	TC 400	PT 0204 BN PT 0203 BN
Air cooling	Yes	Yes	Yes	Yes	PT 0500 BN
Backing pump: Multi-stage Roots pump	ACP 15 / 28	ACP 15 / 28	ACP 15 / 28	ACP 15 / 28	112369 O
Backing pump: Rotary vane pump	Duo 11 M Duo 20 M	Duo 11 M Duo 20 M	Duo 11 M Duo 20 M	Duo 11 M Duo 20 M	PD 0070 BN PK 0203 BN
Backing pump: Rotary vane pump	Pascal 2010 Pascal 2021	Pascal 2010 Pascal 2021	Pascal 2010 Pascal 2021	Pascal 2010 Pascal 2021	103275 O
Power supply with display and control unit	DCU 110	DCU 310	DCU 400	DCU 400	PT 0250 BN
Venting valve	optional	optional	optional	optional	PT 0228 BN
Housing heater (water cooling required)	optional, only with CF flange	optional, only with CF flange	optional, only with CF flange	optional, only with CF flange	PT 0233 BN
Control adapter for accessories	Yes	Yes	Yes	Yes	PT 0521 BN

Table 1: Selection of turbopumps, backing pumps, and accessories for pumping stations HiCube Pro

4.1 Product identification

4.1.1 Product characteristics

To correctly identify the product when communicating with Pfeiffer Vacuum, always have the information from the rating plate available.



Fig. 1: Example for a rating plate

4.1.2 Scope of delivery

- HiCube Pro
- Only with rotary vane pump as backing pump: operating fluid and filler tube
- Mains cable
- Grounding cable, 3 m (incl. fixing material)
- Protective cover for the high vacuum flange
- Operating manuals for pumping station and individual components

4.2 Function

Turbo pumping stations are fully automatic pump units which are ready for connection. A turbo pumping station consists of a portable or mobile vacuum pumping unit with a turbopump and a specially matched backing pump.

The display and control unit DCU serves to control and monitor the pumping station.

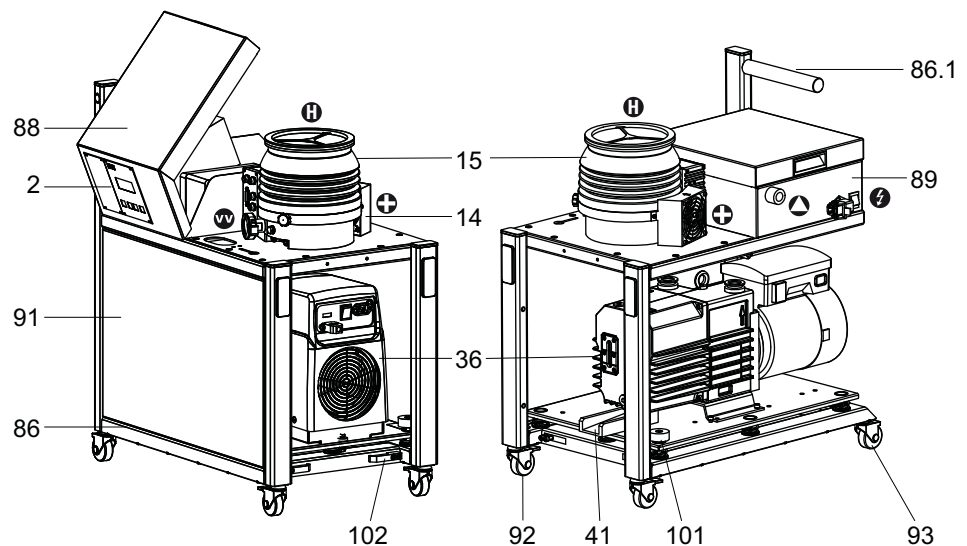

Fig. 2: HiCube Pro Overview

2	Display and control unit DCU	88	Electronics housing
14	Air cooling	89	Housing for controls
15	HiPace turbopump	91	Cover plate
36	Backing pump	92	Guide roller with locking brake
41	Operating fluid channel	93	Guide roller
86	Frame	101	Transport protection
86.1	Transportation handle	102	Retaining hook

4.2.1 Control

Electronic drive unit of the turbopump

4.2.2 Cooling

- Air cooling
- Water cooling (optional)

In the case of excess temperature the electronic drive unit reduces the drive power automatically.

4.3 Range of application

The pumping station HiCube Pro must be installed and operated in the following ambient conditions.

Installation location	weather protected (indoors)
Protection category	IP 20
Protection class	I
Temperature	+5 °C to +40 °C (up to +35 °C with air cooling)
Relative humidity	max. 80 %, at T ≤ 31 °C, up to max. 50% at T ≤ 40 °C
Atmospheric pressure:	750 hPa - 1060 hPa
Installation altitude	2000 m max.
Degree of pollution	2
Overvoltage category	II
Connection voltage TC	24 or 48 V DC ±5%

Limit values for	HiPace 80	HiPace 300	HiPace 400	HiPace 700
Permissible magnetic field max.	3.3 mT	5.5 mT	6 mT	6 mT
Permissible irradiated heat input	3 W	8 W	14 W	14 W



Remarks to ambient conditions

The specified permissible ambient temperatures apply to operation of the turbopump at maximum permissible fore-vacuum pressure or at maximum gas throughput depending on the cooling method. The turbopump is intrinsically safe by a redundant temperature monitoring.

- By reducing the fore-vacuum pressure or gas throughput, the turbopump can be operated at higher ambient temperatures.
- If the maximum permissible operating temperature of the turbopump is exceeded, the electronic drive unit reduces drive power first and switches off then, if necessary.

5 Installation

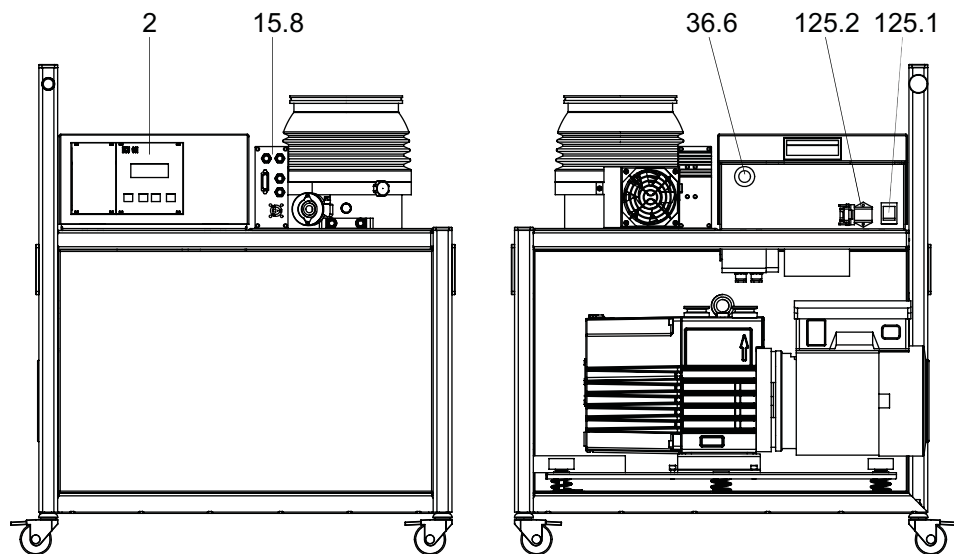

Fig. 3: HiCube Pro, connections

- | | | | |
|------|-------------------------------------|-------|--------------|
| 2 | Display and control unit | 125.1 | Main switch |
| 15.8 | Electronic drive unit for turbopump | 125.2 | Power supply |
| 36.6 | Exhaust connection | | |

5.1 Preparatory work

The installation location is to be chosen so that components that need servicing are freely accessible at all times. No special foundations or base are necessary for installation. The unit must not be used outdoors. Conditions are:

- the ambient conditions specified for the range of application
 - a level, vibration-free surface.
 - Distance to side walls or adjacent devices: at least 50 cm.
 - When using a casing heating and a water cooling unit the temperature of the connected flange of the vacuum chamber must not exceed 120 °C.
 - It is not allowed to operate the device in systems where impact-like stresses and vibrations or periodically forces occur.
- Ensure sufficient cooling for the pumping station.
- When magnetic fields exceed the approved values, a suitable shielding must be used. Check installation location and consult Pfeiffer Vacuum if needed!
- The maximum permissible rotor temperature for the turbopump is 90 °C. If high temperatures arise for process reasons, the radiated heat input must not exceed the permissible values. Install suitable screening sheets, if necessary (design information on request).

5.2 Set-up

5.2.1 Earthing



NOTICE

Danger of missing casing earthing

To comply with the required height of the leakage currents according to DIN EN 61010-1:2010, perform the following measure:

- Connect the earthing cable (consignment) of the pumping station with PE on site, before mains connection.

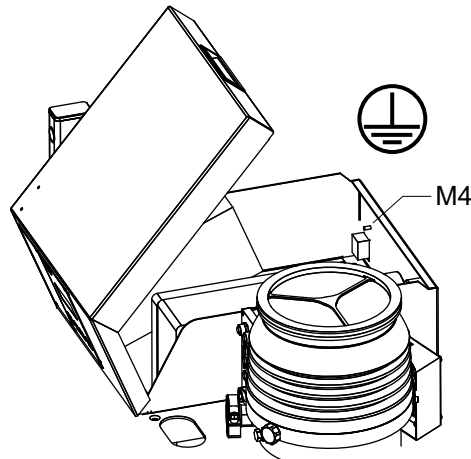

5.2.2 Anchoring the pumping station

In the case the rotor of the turbopump suddenly blocs, the resulting torque must be absorbed via the pumping station frame by the fixture provided by the customer. Anchoring the pumping station is mandatory in order to secure the pumping station and the vacuum system. For this purpose, there are 3 securing hooks at the lower corners of the pumping station frame.

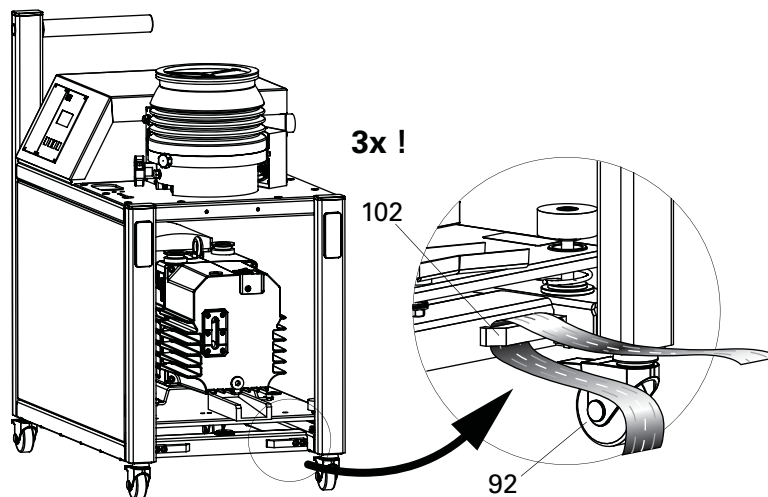

Fig. 4: Anchoring the pumping station

102 Securing hooks 92 Roller

- Lock all pumping station roller brakes.
- Fasten the pumping station with lashing straps at all 3 securing hooks.
 - Pay attention to the fit and the stress of the straps; the strap loop has to be in the recess of the securing hook.
 - Fasten securely the lashing straps provided by the the customer in order to be able to hold loads up to 2000 N per anchorage point.

5.3 Connecting the high vacuum side

The assembly of superstructures on the pumping station HiCube Pro is in the operator's responsibility. The load capacity of the high vacuum flange is specific for the used turbopump. The gross weight of superstructures on the pumping station HiCube Pro may **not** exceed 100 kg!

- Observe barycentric shifting by using high or lateral protruding superstructure (e.g. vacuum chamber). **Danger of tilting!**

- Install the high vacuum flange in accordance with the instructions in the operating manual of the turbopump.
- Ensure the greatest possible cleanliness when installing any high vacuum parts. Unclean components prolong the pump-down time.
- Observe the minimum strength of 170 N/mm^2 for the flange material.

5.4 Connecting the exhaust side



CAUTION

High pressure in the exhaust line!

Danger of damage to the seals and danger of the pump bursting.

- Install the line without shut-off valves on the exhaust side.
- Do not operate the pump with excess pressure at the inlet; observe the maximum allowable pressures and pressure differences.
- Prepare the exhaust line provided by customer starting from the pumping station's casing.
- Choose the cross-section of the exhaust line to be at least the size of the nominal connection diameter of the vacuum pump's exhaust connection.
- Piping to the pump must be suspended or supported.
 - Physical forces from the piping system must not be allowed to act on vacuum pumps.
- Lay piping from the pump sloping downward so that no condensate can flow back into the pump; otherwise fit a condensate separator.
 - If an air trap is created in the system, then a device for draining condensation water must be provided at the lowest point.

5.5 Connecting an external turbopump

Depending on the configuration the turbopump can be operated separately from the pumping station. Please observe the following installation information!

- Install the turbopump according to its operating instructions.
- Open the casing of the pumping station, if necessary.
- Extend necessary control leads for the electronic drive unit of the turbopump using Pfeiffer Vacuum accessories.
- Connect the control leads to the electronic drive unit.



Operation of the turbopump with the electronic drive unit separate

The operation of the turbopump with a separated electronic drive unit is only possible using the respective Pfeiffer Vacuum accessories.

5.5.1 Connecting the high vacuum side

- Install the high vacuum flange in accordance with the instructions in the operating manual of the turbopump.
- Ensure the greatest possible cleanliness when installing any high vacuum parts. Unclean components prolong the pump-down time.
- Observe the minimum strength of 170 N/mm^2 for the flange material.

5.5.2 Connecting the fore-vacuum side

- Extend the fore-vacuum line between turbopump and backing pump.
- Connect the fore-vacuum line with small-flange components or threaded hose couplings. Do not narrow the free cross section of the fore-vacuum flange!

- With rigid pipe connections: Install bellows for attenuation of vibrations in the connection line.

5.6 Transportation lock

Turbo pumping stations of the HiCube Pro line are equipped with transportation lock for the backing pumps (see label). The transportation lock consists of two opposing knurled screws with spring suspension which fasten the backing pump's bottom plate.

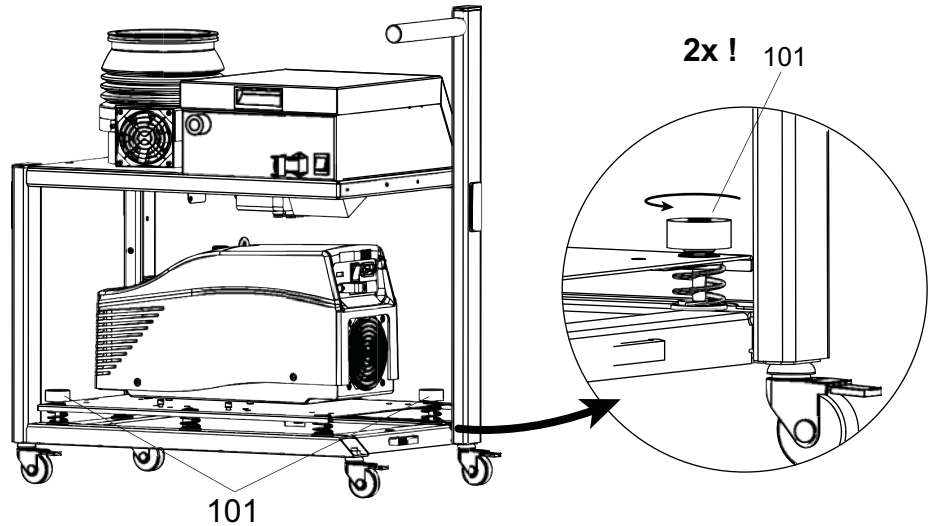

Fig. 5: Transportation lock at HiCube Pro

101 Transportation lock

- Loosen the knurled screw of the transportation lock.
- Similarly loosen the transportation lock on the opposite side.

5.7 Filling up the operating fluid

Only applies to HiCube with rotary vane pump as backing pump!

- The operating fluid reservoir is already filled and installed for the turbopump.
- The dry compressing backing pump ACP is already filled with lubricant.
- The operating fluid for the rotary vane pump is enclosed with the delivery.

- Unscrew the operating fluid bottle's screw plug and screw the filler tube (both included in the equipment pack).

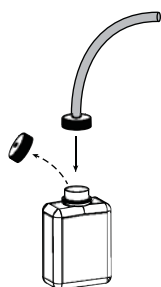

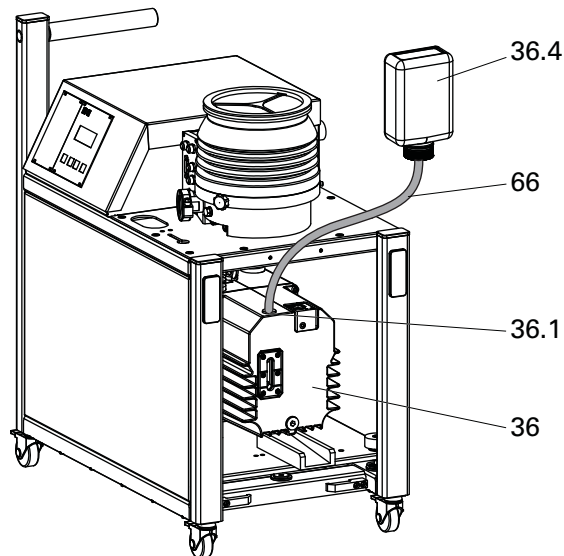

Fig. 6: Fill the backing pump with operating fluid

36	Backing pump: Rotary vane pump	36.4	Operating fluid bottle (similar to illustration)
36.1	Filler opening/filler screw	66	Filler tube

- Unscrew operating fluid filler screw 36.1.
- Insert the filler tube into the rotary vane pump's filler opening.
- Fill operating fluid according to rotary vane pump operating instructions.
- Screw in operating fluid filler screw 36.1.
- Check fill level: The correct fill level is between the markings on the sight glass.
 - If the fill level drops below the "Min" marking, add operating fluid.

5.8 Connecting accessories



Installation and operation of accessories

Pfeiffer Vacuum pumps can be equipped with a series of adapted accessories. The installation, operation and maintenance of connected devices are described in detail in the operating instructions of the individual components.

- For information on order numbers of components, see "Accessories".
- Use original accessory parts only.



NOTICE

Dangerous excess temperatures

Process-related high temperatures can result in impermissible excess temperatures and thus damage to the turbopump.

- Water cooling must be used when employing a casing heating or during operation with heated vacuum chambers.
- Do not introduce any additional energy into the pump (see p. 19, chap. 6.1).

- The air cooling serves to the cooling of Pfeiffer Vacuum turbopumps at ambient temperatures of max. + 35 °C.
- A venting valve is installed and connected to the turbopump.
- Generally use water cooling if the ambient temperature is > +35 °C.
- Connect additional accessories according to the operating manual of the turbopump.

5.8.1 Connecting a measuring device

The connection of a vacuum gauge (e.g. Pfeiffer Vacuum ActiveLine) is possible to the display and control unit DCU.

Connect the transmitter appropriately (see operating instruction of the ActiveLine transmitter).

→ Open the cover of the casing for electronics.

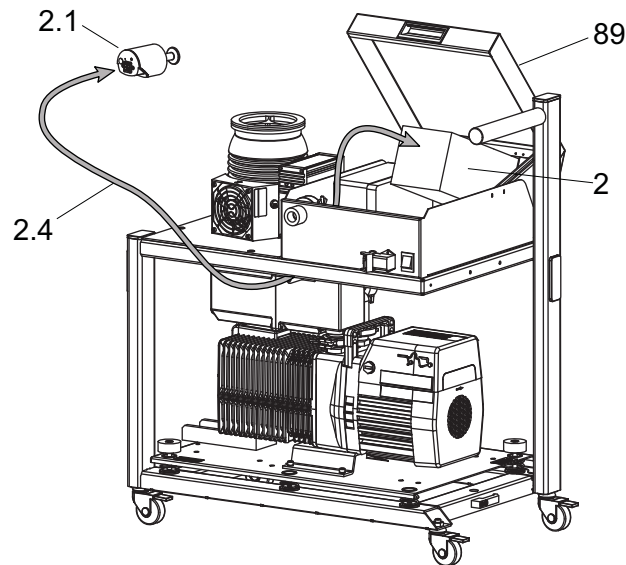

Fig. 7: HiCube Pro, running a measuring cable

2	Display and control unit	2.4	Measuring cable
2.1	Measuring gauge	89	Control casing

→ Run the measuring cable into the casing for electronics from below.

→ Plug the measuring cable in the connection X3 of the DCU.

→ Settings are possible with the extended parameter set at the DCU.

5.9 Connecting to the mains power supply



WARNING

Danger of unsafe electrical installation

Safe operation after installation is the responsibility of the operator.

→ Do not independently modify or change the pump and electrical equipment.

→ Make sure that the system is integrated in an emergency off safety circuit.

→ Consult Pfeiffer Vacuum for special requirements.

→ Observe the information on the rating plate.

→ Plug the mains cable into the the mains connection on the rear side of the pumping station and fix it with the clip.

→ Connect the mains cable to the mains.

6 Operation

6.1 Commissioning

Important settings for turbopumping stations are preprogrammed in the turbopump's electronic drive unit at the factory.

Parameter	Name	Option	HiCube 80 Pro	HiCube 300 Pro	HiCube 400/700 Pro
[P:001]	Heating	Without heating	0	0	0
		With heating	1	1	1
[P:012]	Enable venting		1	1	1
[P:019]	Configuration of output DO2		13 (= backing pump)	-	-
[P:023]	Motor pump		-	1	1
[P:024]	Configuration of output DO1		-	21 = vacuum valve, delayed	21 = vacuum valve, delayed
[P:025]	Backup pump operating mode	With DUO/Pascal	0 = Continuous operation	0 = Continuous operation	0 = Continuous operation
		With ACP 15/28	1 = intermittent operation	1 = intermittent operation	1 = intermittent operation
[P:035]	Configuration of accessory connection A1	With air cooling	0	0	0
		With water cooling	2	2	2
[P:036]	Configuration of accessory connection B1		1 = Venting valve, normally closed	1 = Venting valve, normally closed	1 = Venting valve, normally closed
[P:046]	Configuration of relay 2		-	15 = pumping station	15 = pumping station
[P:047]	Configuration of relay 3		-	13 = backing pump	13 = backing pump
[P:055]	Configuration of output AO2		8 = Fore-vacuum triggering	-	-
[P:710]	Backing pump switch-off threshold for intermittent operation	With DUO/Pascal	0 W	0 W	0 W
		With ACP 15/28	10 W	50 W	65 W
[P:711]	Backing pump switch-on threshold for intermittent operation	With DUO/Pascal	0 W	0 W	0 W
		With ACP 15/28	20 W	70 W	110 W

Table 2: Factory configuration of important parameters for HiCube Pro pumping stations

- Loosen the transportation lock before first-time starting.
- When water cooling is used: Open cooling water supply and check the flow.
- When sealing gas is used: Open the sealing gas supply and check the flow.



Comply run-up time

Pump throughput can be impaired by condensate or remaining moisture in the backing area. This can lead to exceeding the maximum run-up time.

- **Recommendation:** When switching on, open the gas ballast valve for about 5 min. (see p. 21, chap. 6.4).



NOTICE

Danger of the pump being destroyed

Pumping of gases with a higher molecular mass in the wrong gas mode can lead to destruction of the pump.

- Ensure the gas mode is correctly set.
- Contact Pfeiffer Vacuum before using gases with a greater molecular mass (> 80).

6.2 Operation modes

The following operation modes are available:

- Operation via RS-485 and Pfeiffer Vacuum display and control units or PC

6.3 Function description



WARNING
<p>Danger due to open high vacuum flange</p> <p>The rotor of the turbopump turns at high speed. If the high vacuum flange is open, there is a danger of cut injuries and that the pump can be destroyed by objects falling into it.</p> <p>→ Never operate the pump with an open high vacuum flange.</p>

6.3.1 Operation with DCU

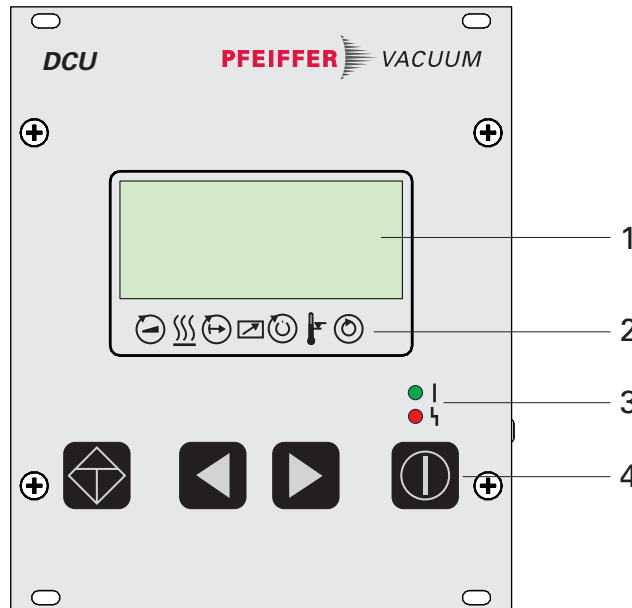

Fig. 8: Front cover DCU

- | | | | |
|---|-------------------------|---|-------------------------|
| 1 | LC display, illuminated | 3 | LED "Operating display" |
| 2 | Status symbols | 4 | Operating keys |

→ Consider the following manuals for the operation via Pfeiffer Vacuum display and control units:

- Operating instructions "DCU"
- Operating instructions "Electronic drive unit"



- Switch on the mains supply via the main switch.
- Switch on the pumping station using key "ON/OFF" on the DCU.
- Settings are possible with the extended parameter set at the DCU.

6.3.2 Saving energy

Depending on the power consumption of the turbopump the electronic drive unit can control the backing pump operation. Consequently, the supplied fore-vacuum pressure depends on the turbopump power consumption. Standby operation of the backing pump can reduce the overall power consumption of the pumping system and the operating temperature of the backing pump as well.

- Standby mode with the ACP (preset)
- Standby mode with rotary vane pumps (configurable)

Standby mode with the ACP

Switching thresholds for the standby mode of the ACP are preset.

HiCube with turbopump and ACP	Switching Off threshold backing pump [P:710]	Switching On threshold backing pump [P:711]
HiPace 80 / TC 110	10 W	20 W

HiCube with turbopump and ACP	Switching Off threshold backing pump [P:710]	Switching On threshold backing pump [P:711]
HiPace 300 / TC 400	50 W	70 W
HiPace 400 / TC 400	65 W	110 W
HiPace 700 / TC 400	65 W	110 W

Standby mode with rotary vane pumps

The switching thresholds for the rotary vane pumps as backing pumps are adjustable via the DCU. Fluctuations in the power consumption of idling turbopumps and type-dependent varying fore-vacuum pressures of the backing pumps require the switching thresholds to be set separately for the standby mode.

- Determine the switching thresholds for standby operation of the rotary vane pump on customer side.
- Parameter [P:794] = 1 (display extended parameter set)
- Parameter [P:025] = 1
- Configure thresholds [P:710] and [P:711] according to the operating instructions "Electronic Drive Unit".

6.4 Operation with gas ballast valve

Steam or moisture from pumped media can condense in the vacuum pump and hence impair the suction performance.

Letting in gas ballast improves the discharge of condensate, and the pump achieves the specified final vacuum more quickly. The gas ballast valve can be replaced with a flushing gas connection if necessary.

- For operation with gas ballast, please refer to the operating manual for the backing pump.



Elimination of large amounts of condensate

If the open gas ballast valve alone is not sufficient to reduce the condensate load, the pumping system with switched off turbopump can be relieved additionally via the venting connection.

- Prerequisite is an existing display and control unit.
- Admit dry inert gas at the venting connection, if possible.



- Switch off the pumping station via the "ON/OFF" button on the DCU.
- Place backing pump and venting valve in continuous operation.
 - Parameter [P:023] = 0 (turbopump motor off)
 - Parameter [P:025] = 0 (continuous operation mode for backing pump)
 - Parameter [P:036] = 7 (venting valve continuous 1)
- Switch on the pumping station using key "ON/OFF" on the DCU.
- With the turbopump idle, open the venting screw or allow the venting process to complete using the connected venting valve.
- Clear condensate from the pumping system for around 5 minutes.
- Repeat this process if necessary.
- Restore the initial configuration (see p. 19, chap. 6.1).
- Place the turbopumping station back in operation.

6.5 Operation with fore-vacuum valve

The fore-vacuum safety valve (optional accessory) is located in the fore-vacuum line between the turbopump and the backing pump. It protects the process vacuum and the turbopump from inadvertent venting after switching-off the backing pump or in case of power failure. In order to prevent gas backflow while switching on the fore-vacuum safety valve opens time delayed to the other pumping station components. The valve is currentless closed.

- [P:010] Pumping station "On" = Fore-vacuum safety valve opens after 8 seconds.
- [P:010] Pumping station "Off" = Fore-vacuum safety valve is closed.

6.6 Switching off and venting

6.6.1 Switching off

After the turbopump is switched off, it must be vented to avoid contamination due to particles streaming back from the fore-vacuum area.

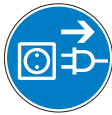

WARNING
<p>Danger of electric shock</p> <p>The pumping station is only free of voltages when the mains plug has been disconnected.</p> <p>→ Switch off the master switch and disconnect the mains plug before all work.</p> <p>→ Secure against unintentional restarting.</p>

- Switch off the pumping station via the "ON/OFF" button on the DCU.
- Venting.
- Switch off the pumping station at the master switch.
- For water cooling: Shut off the water supply.

6.6.2 Venting

Venting with Pfeiffer Vacuum Venting Valve

- Enable venting via the functions of the electronic drive unit.
- Settings are possible via interface RS-485 by using DCU, HPU or PC.

Venting rotation speed	Switch off the pumping station	Mains power failure ¹⁾
50 % of the nominal rotation speed	Venting valve opens for 3600 s (1 h, works setting)	Venting valve opens for 3600 s (1 h, works setting)

¹⁾When mains power is restored the venting procedure is aborted.

Basic information for the rapid venting

Venting of the vacuum chamber in two steps. Ask for details on individual solutions from Pfeiffer Vacuum.

- Vent for 20 seconds at a rate of pressure rise of max. 15 hPa/s.
 - The valve cross section for the venting rate of 15 hPa/s must be adapted to the size of the vacuum chamber.
 - For small vacuum chambers, use the Pfeiffer Vacuum venting valve.
- Then vent with an additional venting valve of any desired size.

7 Maintenance / replacement



WARNING

Contamination of parts and operating fluid by pumped media is possible.

Poisoning hazard through contact with materials that damage health.

- In the case of contamination, carry out appropriate safety precautions in order to prevent danger to health through dangerous substances.
- Decontaminate affected parts before carrying out maintenance work.



NOTICE

Disclaimer of liability

Pfeiffer Vacuum accepts no liability for personal injury or material damage, losses or operating malfunctions due to improperly performed maintenance. The liability and warranty entitlement expires.



WARNING

Danger of electric shock

The pumping station is only free of voltages when the mains plug has been disconnected.

- Switch off the master switch and disconnect the mains plug before all work.
- Secure against unintentional restarting.



7.1 Maintenance intervals and responsibilities

- Clean the pumping station externally with a lint-free cloth and little industrial alcohol.
- Carry out the required maintenance on the components of the pumping station in accordance with the instructions in the individual operating manuals.
- Clarify shorter maintenance intervals for extreme loads or impure processes with Pfeiffer Vacuum Service.
- For all other cleaning, maintenance or repair work, please contact your Pfeiffer Vacuum service location.

7.2 Removal of components for their maintenance

In some cases, components may need to be dismantled from the pumping station so that customers can carry out necessary maintenance work on them (they should then be re-assembled in reverse order).

7.2.1 Preparatory work



- Switch off the pumping station via the "ON/OFF" button on the DCU.
- Venting.

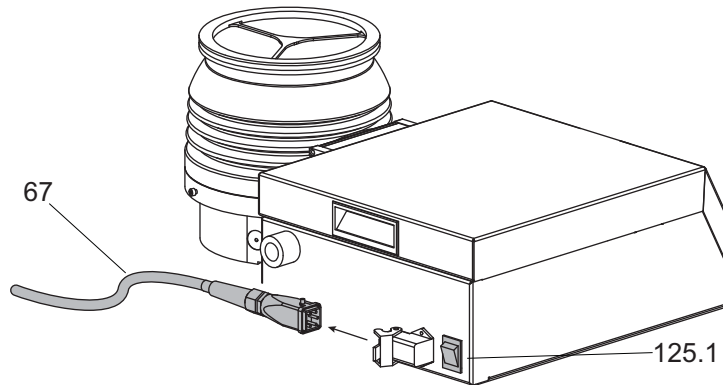

Fig. 9: Disconnecting the pumping station from the mains safely

67 Mains cable 125.1 Main switch

- Switch off the pumping station at the master switch.
- Disconnect the mains plug.
- For water cooling: Shut off the water supply.

7.2.2 Dismantling of the turbopump

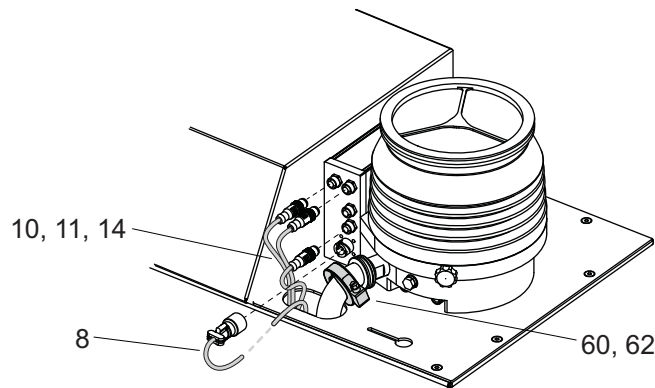

Fig. 10: HiCube Pro - turbopump connections (example)

8	Power supply cable	14	Control cable for air cooling
10	DCU/TC interface cable	60	Fore-vacuum connection, locking ring
11	Control cable for fore-vacuum connection	62	Fore-vacuum connection, centering ring

- Remove the connector plug from the electronic drive unit.
- Detach and remove the fore-vacuum line from the turbopump.
 - Do not damage the fore-vacuum components.



NOTICE

Note the factory settings.

The accessory connections on the turbopump have been preconfigured at the factory. Interchanging the control leads on the connector causes the pumping station to malfunction or fail.

- Do not interchange the control leads.
- Accessory connections can be configured for operation with the DCU.
 - For more information refer to the operating instructions for the electronic drive unit of the turbopump.

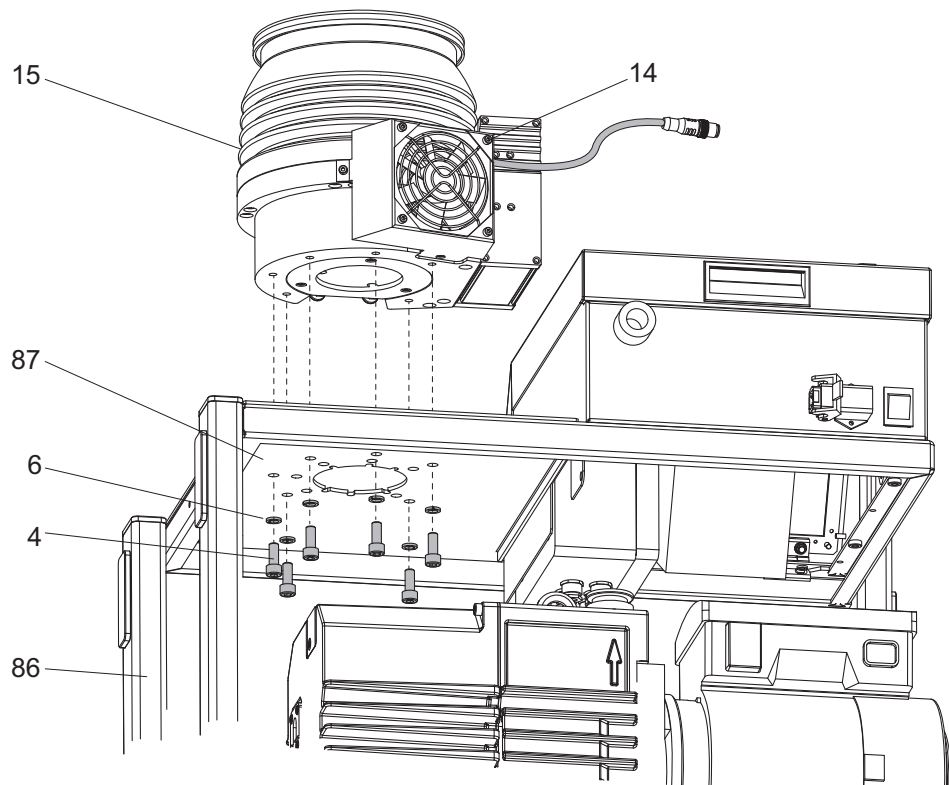

Fig. 11: HiCube Pro - turbopump assembly/disassembly

4	Hexagon socket screw	15	Turbopump
6	Washer	86	Pumping station frame
14	Air cooling	87	Mounting plate

- ➔ Remove all mounting screws (depending on the turbopump) with washers from the mounting plate from below.
- ➔ Lift the turbopump from the mounting plate.
 - Take care with the control cable for the air cooling.
- ➔ If necessary, remove the air cooling from the turbopump.
- ➔ Perform turbopump maintenance in accordance with the instructions in the operating instructions.

7.2.3 Installing the turbopump

Once maintenance is complete, attach the turbopump to the mounting plate in the reverse order. The tightening torque for the socket cap screw is dependent on its size and the type of turbopump.

- ➔ Remember to use washers.

Turbopump	Mounting screw	Quantity	Tightening torque
HiPace 80	Hexagon socket, M5x12	6	10 Nm
HiPace 300	Hexagon socket, M8x20	5	30 Nm
HiPace 400	Hexagon socket, M8x20	6	30 Nm
HiPace 700	Hexagon socket, M8x20	6	30 Nm

Table 3: Tightening torque for mounting turbopump for HiCube Pro

7.3 Changing the operating fluid

Only applies to HiCube with rotary vane pump as backing pump!



WARNING

Operating fluid may contain toxic substances from the pumped media!

Danger of poisoning from the emission of harmful substances from the operating fluid.

- Wear suitable protective clothing and respirators.
- Dispose of operating fluid according to the local regulations



WARNING

Hot operating fluid!

Danger of burns when draining due to contact with skin.

- Wear suitable protective clothing.
- Use a suitable collecting vessel.

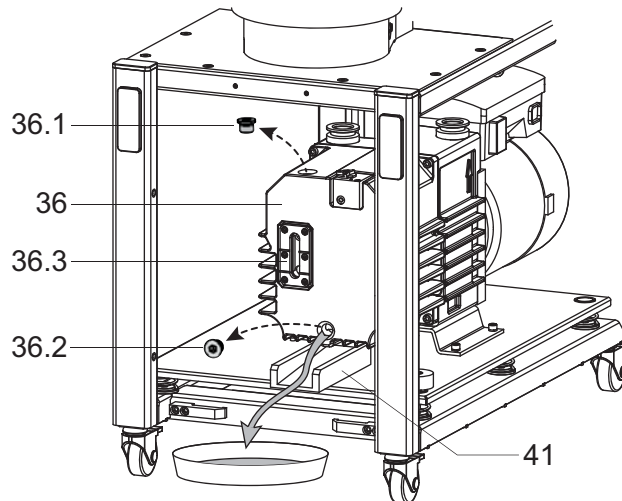

Fig. 12: Change of operating fluids for HiCube Pro with rotary vane pump

36 Backing pump
36.1 Filler screw

36.2 Drain plug
41 Operating fluid channel

- Put a suitable container under the operating fluid duct.
- Change the operating fluid according to the operating instructions of the rotary vane pump.
- Fill up the operating fluid. (see p. 16, chap. 5.7)

8 Decommissioning

8.1 Shutting down for longer periods



WARNING

Contamination of parts and operating fluid by pumped media is possible.

Poisoning hazard through contact with materials that damage health.

- In the case of contamination, carry out appropriate safety precautions in order to prevent danger to health through dangerous substances.
- Decontaminate affected parts before carrying out maintenance work.

If the pumping station should be shut down for longer than a year:

- Remove the pumping station from the system, if necessary.
- Replace the operating fluid reservoir of the turbopump, if necessary.
- Only store the pumping station indoors at an ambient temperature between -10 °C and +40 °C.
- In rooms with moist or aggressive atmospheres, the pumping station must be airtight and shrink-wrapped in a plastic bag together with a bag of desiccant.

8.2 Re-starting



NOTICE

Risk of damage to the pump following recommissioning

The operating fluid in the turbo pump has a limited shelf life. The length of its shelf life is as follows:

- max. 2 years without operation or
 - a total of max. 4 years following periods of operation and nonoperation.
- Follow the maintenance instructions and inform Pfeiffer Vacuum.

- Check pumping station for contamination and moisture.
- Clean the pumping station externally with a lint-free cloth and little industrial alcohol.
- If necessary, have Pfeiffer Vacuum Service clean the pumping station completely.
- Installation and commissioning in accordance with the operating instructions.

8.3 Disposal

Products or parts thereof (mechanical and electrical components, operating fluids, etc.) may cause environmental burden.

- Safely dispose of the materials according to the locally applicable regulations.

9 Malfunctions

Malfunctions on the pumping station are usually caused by faults on individual components. Faults are indicated by the LEDs at the electronic drive unit of the turbopump. Alternatively, a fault code can also be output at the display and control unit DCU.

9.1 Rectifying malfunctions

Problem	Possible causes	Remedy
Pumping station will not start; none of the integrated LEDs on the electronic drive unit of the turbopump light up	• Electrical supply interrupted	⇒ Check the plug contacts at the relay box and the power supply unit. ⇒ Check the supply lines of the pumping station. ⇒ Check the output voltage (24 V DC) at the "DC out" terminal of the power supply unit ⇒ Check the plug contacts on the power supply unit
	• Incorrect operating voltage	⇒ Apply correct operating voltage ⇒ Observe the ratings on the type plate.
	• No operating voltage applied	⇒ Apply the correct operating voltage.
	• Electronic drive unit defective	⇒ Replace the electronic drive unit. ⇒ Contact Pfeiffer Vacuum Service.
Pump not achieving the required ultimate pressure	• Condensate in the backing pump	⇒ Open the gas ballast valve at the backing pump.
	• Gas ballast valve open	⇒ Close the gas ballast valve at the backing pump.

- Please refer to the relevant operating manual for troubleshooting at pumping station components.
- For additional queries, contact Pfeiffer Vacuum Service.

10 Service

Pfeiffer Vacuum offers first-class service!

- Operating fluid and bearing change on the spot by Pfeiffer Vacuum FieldService
- Maintenance / repair in the nearby ServiceCenter or ServicePoint
- Fast replacement with exchange products in mint condition
- Advice on the most cost-efficient and quickest solution

Detailed information, addresses and forms at: www.pfeiffer-vacuum.com (Service).

Maintenance and repair in the Pfeiffer Vacuum ServiceCenter

The following steps are necessary to ensure a fast, smooth servicing process:

- Download the forms "Service Request" and "Declaration on Contamination".¹⁾
- Fill out the "Service Request" form and send it by fax or e-mail to your Pfeiffer Vacuum service address.
- Include the confirmation on the service request from Pfeiffer Vacuum with your shipment.
- Fill out the declaration on contamination and include it in the shipment (required!).
- Dismantle all accessories.
- Drain the operating fluid (applies for turbopumps with pumping speed > 700 l/s).
- Leave electronic drive on the pump.
- Close the flange openings by using the original protective covers.
- If possible, send pump or unit in the original packaging.

Sending of contaminated pumps or devices

No units will be accepted if they are contaminated with micro-biological, explosive or radioactive substances. "Hazardous substances" are substances and compounds in accordance with the hazardous goods directive (current version). If pumps are contaminated or the declaration on contamination is missing, Pfeiffer Vacuum performs decontamination at the shipper's expense.

- Neutralise the pump by flushing it with nitrogen or dry air.
- Close all openings airtight.
- Seal the pump or unit in suitable protective film.
- Return the pump/unit only in a suitable and sturdy transport container and send it in while following applicable transport conditions.

Exchange unit

The factory operating parameters are always preset with exchange units. If you use changed parameters for your application, you have to set these again.

Service orders

All service orders are carried out exclusively according to our repair conditions for vacuum units and components.

¹⁾ Forms under www.pfeiffer-vacuum.com

11 Spare parts HiCube Pro

Please also specify model number of the the rating plate when ordering accessories or spare parts.

Refer to the operating manuals for the individual components.

12 Accessories

Please also specify model number of the the rating plate when ordering accessories or spare parts.

Refer to the operating manuals for the individual components.

13 Technical data

13.1 General

Basic principles for the Technical Data of Pfeiffer Vacuum Turbopumps:

Maximum values refer exclusively to the input as a single load.

- Recommendations of PNEUROP committee PN5
- ISO 21360; 2007: "Vacuum technology - Standard methods for measuring vacuum-pump performance - General description"
- ISO 5302; 2003: "Vacuum technology - Turbomolecular pumps - Measurement of performance characteristics"
- Ultimate pressure: using a test dome and a 48 hrs. period of baking out
- Integral leak rate: using a Helium concentration of 100 %, period 10 s

Conversion table: pressure units

	mbar	bar	Pa	hPa	kPa	Torr mm Hg
mbar	1	$1 \cdot 10^{-3}$	100	1	0.1	0.75
bar	1000	1	$1 \cdot 10^5$	1000	100	750
Pa	0.01	$1 \cdot 10^{-5}$	1	0.01	$1 \cdot 10^{-3}$	$7.5 \cdot 10^{-3}$
hPa	1	$1 \cdot 10^{-3}$	100	1	0.1	0.75
kPa	10	0.01	1000	10	1	7.5
Torr mm Hg	1.33	$1.33 \cdot 10^{-3}$	133.32	1.33	0.133	1

1 Pa = 1 N/m²

Conversion table: gas throughput units

	mbar·l/s	Pa·m ³ /s	sccm	Torr·l/s	atm·cm ³ /s
mbar·l/s	1	0.1	59.2	0.75	0.987
Pa·m ³ /s	10	1	592	7.5	9.87
sccm	$1.69 \cdot 10^{-2}$	$1.69 \cdot 10^{-3}$	1	$1.27 \cdot 10^{-2}$	$1.67 \cdot 10^{-2}$
Torr·l/s	1.33	0.133	78.9	1	1.32
atm·cm ³ /s	1.01	0.101	59.8	0.76	1

Information relating to technical data on HiCube Pro

- Versions available for:
 - Netzanschluss 230 V AC, 50/60 Hz
 - Netzanschluss 110 V AC, 50/60 Hz
- Environmental conditions (see p. 12, chap. 4.3)
- Weight specification including fore-vacuum valve (optional for version with rotary vane pump)

13.2 HiCube 80 Pro

13.2.1 DN 40 ISO-KF

Parameter	HiCube 80 Pro	HiCube 80 Pro	HiCube 80 Pro	HiCube 80 Pro	HiCube 80 Pro	HiCube 80 Pro
Flange (in)	DN 40 ISO-KF	DN 40 ISO-KF	DN 40 ISO-KF	DN 40 ISO-KF	DN 40 ISO-KF	DN 40 ISO-KF
Flange (out)	G 1/2"	G 1/2"	G 1/2"	G 1/2"	G 1/2"	G 1/2"
Pumping speed for N ₂	35 l/s	35 l/s	35 l/s	35 l/s	35 l/s	35 l/s
Pumping speed backing pump at 50 Hz	14 m ³ /h	27 m ³ /h	9 m ³ /h	20 m ³ /h	9 m ³ /h	18 m ³ /h
Pump-down time for vacuum chamber size 10 l	21 s	12 s	24,13 s	10,72 s	21,22 s	10,18 s
Pump-down time for vacuum chamber size 100 l	208 s	116 s	241,3 s	107,2 s	212,2 s	101,8 s
Pump-down time for vacuum chamber size 1000 l	2079 s	1161 s	2413 s	1072 s	2122 s	1018 s
Ultimate pressure	< 1 · 10 ⁻⁷ hPa	< 1 · 10 ⁻⁷ hPa	< 1 · 10 ⁻⁷ hPa	< 1 · 10 ⁻⁷ hPa	< 1 · 10 ⁻⁷ hPa	< 1 · 10 ⁻⁷ hPa
Weight	64 kg	87 kg	63,9 kg	88,9 kg	70,9 kg	72,9 kg
Cooling method, standard	Air	Air	Air	Air	Air	Air
Turbopump	HiPace 80	HiPace 80	HiPace 80	HiPace 80	HiPace 80	HiPace 80
Backing pump	ACP 15	ACP 28	DUO 11 M	DUO 20 M	Pascal 2010	Pascal 2021

13.2.2 DN 63 ISO-K

Parameter	HiCube 80 Pro	HiCube 80 Pro	HiCube 80 Pro	HiCube 80 Pro	HiCube 80 Pro	HiCube 80 Pro
Flange (in)	DN 63 ISO-K	DN 63 ISO-K	DN 63 ISO-K	DN 63 ISO-K	DN 63 ISO-K	DN 63 ISO-K
Flange (out)	G 1/2"	G 1/2"	G 1/2"	G 1/2"	G 1/2"	G 1/2"
Pumping speed for N ₂	67 l/s	67 l/s	67 l/s	67 l/s	67 l/s	67 l/s
Pumping speed backing pump at 50 Hz	14 m ³ /h	27 m ³ /h	9 m ³ /h	20 m ³ /h	9 m ³ /h	18 m ³ /h
Pump-down time for vacuum chamber size 10 l	21 s	12 s	24,13 s	10,72 s	21,22 s	10,18 s
Pump-down time for vacuum chamber size 100 l	208 s	116 s	241,3 s	107,2 s	212,2 s	101,8 s
Pump-down time for vacuum chamber size 1000 l	2079 s	1161 s	2413 s	1072 s	2122 s	1018 s
Ultimate pressure	< 1 · 10 ⁻⁷ hPa	< 1 · 10 ⁻⁷ hPa	< 1 · 10 ⁻⁷ hPa	< 1 · 10 ⁻⁷ hPa	< 1 · 10 ⁻⁷ hPa	< 1 · 10 ⁻⁷ hPa
Weight	64 kg	87 kg	63,9 kg	88,9 kg	70,9 kg	72,9 kg
Cooling method, standard	Air	Air	Air	Air	Air	Air
Turbopump	HiPace 80	HiPace 80	HiPace 80	HiPace 80	HiPace 80	HiPace 80
Backing pump	ACP 15	ACP 28	DUO 11 M	DUO 20 M	Pascal 2010	Pascal 2021

13.2.3 DN 63 CF-F

Parameter	HiCube 80 Pro	HiCube 80 Pro	HiCube 80 Pro	HiCube 80 Pro	HiCube 80 Pro	HiCube 80 Pro
Flange (in)	DN 63 CF-F	DN 63 CF-F	DN 63 CF-F	DN 63 CF-F	DN 63 CF-F	DN 63 CF-F
Flange (out)	G 1/2"	G 1/2"	G 1/2"	G 1/2"	G 1/2"	G 1/2"
Pumping speed for N ₂	67 l/s	67 l/s	67 l/s	67 l/s	67 l/s	67 l/s
Pumping speed backing pump at 50 Hz	14 m ³ /h	27 m ³ /h	9 m ³ /h	20 m ³ /h	9 m ³ /h	18 m ³ /h
Pump-down time for vacuum chamber size 10 l	21 s	12 s	24,13 s	10,72 s	21,22 s	10,18 s
Pump-down time for vacuum chamber size 100 l	208 s	116 s	241,3 s	107,2 s	212,2 s	101,8 s
Pump-down time for vacuum chamber size 1000 l	2079 s	1161 s	2413 s	1072 s	2122 s	1018 s
Ultimate pressure	< 5 · 10 ⁻¹⁰ hPa	< 5 · 10 ⁻¹⁰ hPa	< 5 · 10 ⁻¹⁰ hPa	< 5 · 10 ⁻¹⁰ hPa	< 5 · 10 ⁻¹⁰ hPa	< 5 · 10 ⁻¹⁰ hPa
Weight	66 kg	89 kg	65,9 kg	90,9 kg	72,9 kg	74,9 kg
Cooling method, standard	Air	Air	Air	Air	Air	Air
Turbopump	HiPace 80	HiPace 80	HiPace 80	HiPace 80	HiPace 80	HiPace 80
Backing pump	ACP 15	ACP 28	DUO 11 M	DUO 20 M	Pascal 2010	Pascal 2021

13.3 HiCube 300 Pro

13.3.1 DN 100 ISO-K

Parameter	HiCube 300 Pro	HiCube 300 Pro	HiCube 300 Pro	HiCube 300 Pro	HiCube 300 Pro	HiCube 300 Pro
Flange (in)	DN 100 ISO-K	DN 100 ISO-K	DN 100 ISO-K	DN 100 ISO-K	DN 100 ISO-K	DN 100 ISO-K
Flange (out)	G 1/2"	G 1/2"	G 1/2"	G 1/2"	G 1/2"	G 1/2"
Pumping speed for N ₂	260 l/s	260 l/s	260 l/s	260 l/s	260 l/s	260 l/s
Pumping speed backing pump at 50 Hz	14 m ³ /h	27 m ³ /h	9 m ³ /h	20 m ³ /h	9 m ³ /h	18 m ³ /h
Pump-down time for vacuum chamber size 10 l	18 s	9 s	23,49 s	10,32 s	21,05 s	10,09 s
Pump-down time for vacuum chamber size 100 l	178 s	91 s	234,9 s	103,2 s	210,5 s	100,9 s
Pump-down time for vacuum chamber size 1000 l	1780 s	913 s	2349 s	1032 s	2105 s	1009 s
Ultimate pressure	$< 1 \cdot 10^{-7}$ hPa	$< 1 \cdot 10^{-7}$ hPa	$< 1 \cdot 10^{-7}$ hPa	$< 1 \cdot 10^{-7}$ hPa	$< 1 \cdot 10^{-7}$ hPa	$< 1 \cdot 10^{-7}$ hPa
Weight	67 kg	90 kg	66,9 kg	91,9 kg	73,9 kg	75,9 kg
Cooling method, standard	Air	Air	Air	Air	Air	Air
Turbopump	HiPace 300	HiPace 300	HiPace 300	HiPace 300	HiPace 300	HiPace 300
Backing pump	ACP 15	ACP 28	DUO 11 M	DUO 20 M	Pascal 2010	Pascal 2021

13.3.2 DN 100 CF-F

Parameter	HiCube 300 Pro	HiCube 300 Pro	HiCube 300 Pro	HiCube 300 Pro	HiCube 300 Pro	HiCube 300 Pro
Flange (in)	DN 100 CF-F	DN 100 CF-F	DN 100 CF-F	DN 100 CF-F	DN 100 CF-F	DN 100 CF-F
Flange (out)	G 1/2"	G 1/2"	G 1/2"	G 1/2"	G 1/2"	G 1/2"
Pumping speed for N ₂	260 l/s	260 l/s	260 l/s	260 l/s	260 l/s	260 l/s
Pumping speed backing pump at 50 Hz	14 m ³ /h	27 m ³ /h	9 m ³ /h	20 m ³ /h	9 m ³ /h	18 m ³ /h
Pump-down time for vacuum chamber size 10 l	18 s	9 s	23,49 s	10,32 s	21,05 s	10,09 s
Pump-down time for vacuum chamber size 100 l	178 s	91 s	234,9 s	103,2 s	210,5 s	100,9 s
Pump-down time for vacuum chamber size 1000 l	1780 s	913 s	2349 s	1032 s	2105 s	1009 s
Ultimate pressure	$< 5 \cdot 10^{-10}$ hPa	$< 5 \cdot 10^{-10}$ hPa	$< 5 \cdot 10^{-10}$ hPa	$< 5 \cdot 10^{-10}$ hPa	$< 5 \cdot 10^{-10}$ hPa	$< 5 \cdot 10^{-10}$ hPa
Weight	69 kg	92 kg	68,9 kg	93,9 kg	75,9 kg	77,9 kg
Cooling method, standard	Air	Air	Air	Air	Air	Air
Turbopump	HiPace 300	HiPace 300	HiPace 300	HiPace 300	HiPace 300	HiPace 300
Backing pump	ACP 15	ACP 28	DUO 11 M	DUO 20 M	Pascal 2010	Pascal 2021

13.4 HiCube 400 Pro

13.4.1 DN 100 ISO-K

Parameter	HiCube 400 Pro	HiCube 400 Pro	HiCube 400 Pro	HiCube 400 Pro	HiCube 400 Pro	HiCube 400 Pro
Flange (in)	DN 100 ISO-K	DN 100 ISO-K	DN 100 ISO-K	DN 100 ISO-K	DN 100 ISO-K	DN 100 ISO-K
Flange (out)	G 1/2"	G 1/2"	G 1/2"	G 1/2"	G 1/2"	G 1/2"
Pumping speed for N ₂	355 l/s	355 l/s	355 l/s	355 l/s	355 l/s	355 l/s
Pumping speed backing pump at 50 Hz	14 m ³ /h	27 m ³ /h	9 m ³ /h	20 m ³ /h	9 m ³ /h	18 m ³ /h
Pump-down time for vacuum chamber size 10 l	18 s	9 s	23,17 s	10,45 s	20,87 s	9,95 s
Pump-down time for vacuum chamber size 100 l	175 s	89 s	231,7 s	104,5 s	208,7 s	99,5 s
Pump-down time for vacuum chamber size 1000 l	1751 s	892 s	2317 s	1045 s	2087 s	995 s
Ultimate pressure	< 1 · 10 ⁻⁷ hPa	< 1 · 10 ⁻⁷ hPa	< 1 · 10 ⁻⁷ hPa	< 1 · 10 ⁻⁷ hPa	< 1 · 10 ⁻⁷ hPa	< 1 · 10 ⁻⁷ hPa
Weight	73 kg	96 kg	72,9 kg	97,9 kg	79,9 kg	81,9 kg
Cooling method, standard	Air	Air	Air	Air	Air	Air
Turbopump	HiPace 400	HiPace 400	HiPace 400	HiPace 400	HiPace 400	HiPace 400
Backing pump	ACP 15	ACP 28	DUO 11 M	DUO 20 M	Pascal 2010	Pascal 2021

13.4.2 DN 100 CF-F

Parameter	HiCube 400 Pro	HiCube 400 Pro	HiCube 400 Pro	HiCube 400 Pro	HiCube 400 Pro	HiCube 400 Pro
Flange (in)	DN 100 CF-F	DN 100 CF-F	DN 100 CF-F	DN 100 CF-F	DN 100 CF-F	DN 100 CF-F
Flange (out)	G 1/2"	G 1/2"	G 1/2"	G 1/2"	G 1/2"	G 1/2"
Pumping speed for N ₂	355 l/s	355 l/s	355 l/s	355 l/s	355 l/s	355 l/s
Pumping speed backing pump at 50 Hz	14 m ³ /h	27 m ³ /h	9 m ³ /h	20 m ³ /h	9 m ³ /h	18 m ³ /h
Pump-down time for vacuum chamber size 10 l	18 s	9 s	23,17 s	10,45 s	20,87 s	9,95 s
Pump-down time for vacuum chamber size 100 l	175 s	89 s	231,7 s	104,5 s	208,7 s	99,5 s
Pump-down time for vacuum chamber size 1000 l	1751 s	892 s	2317 s	1045 s	2087 s	995 s
Ultimate pressure	< 5 · 10 ⁻¹⁰ hPa	< 5 · 10 ⁻¹⁰ hPa	< 5 · 10 ⁻¹⁰ hPa	< 5 · 10 ⁻¹⁰ hPa	< 5 · 10 ⁻¹⁰ hPa	< 5 · 10 ⁻¹⁰ hPa
Weight	79 kg	102 kg	78,9 kg	103,9 kg	85,9 kg	87,9 kg
Cooling method, standard	Air	Air	Air	Air	Air	Air
Turbopump	HiPace 400	HiPace 400	HiPace 400	HiPace 400	HiPace 400	HiPace 400
Backing pump	ACP 15	ACP 28	DUO 11 M	DUO 20 M	Pascal 2010	Pascal 2021

13.5 HiCube 700 Pro

13.5.1 DN 160 ISO-K

Parameter	HiCube 700 Pro	HiCube 700 Pro	HiCube 700 Pro	HiCube 700 Pro	HiCube 700 Pro	HiCube 700 Pro
Flange (in)	DN 160 ISO-K	DN 160 ISO-K	DN 160 ISO-K	DN 160 ISO-K	DN 160 ISO-K	DN 160 ISO-K
Flange (out)	G 1/2"	G 1/2"	G 1/2"	G 1/2"	G 1/2"	G 1/2"
Pumping speed for N ₂	685 l/s	685 l/s	685 l/s	685 l/s	685 l/s	685 l/s
Pumping speed backing pump at 50 Hz	14 m ³ /h	27 m ³ /h	9 m ³ /h	20 m ³ /h	9 m ³ /h	18 m ³ /h
Pump-down time for vacuum chamber size 10 l	17 s	8 s	23,09 s	10,33 s	20,77 s	9,83 s
Pump-down time for vacuum chamber size 100 l	169 s	84 s	230,9 s	103,3 s	207,7 s	98,3 s
Pump-down time for vacuum chamber size 1000 l	1692 s	836 s	2309 s	1033 s	2077 s	983 s
Ultimate pressure	$< 1 \cdot 10^{-7}$ hPa	$< 1 \cdot 10^{-7}$ hPa	$< 1 \cdot 10^{-7}$ hPa	$< 1 \cdot 10^{-7}$ hPa	$< 1 \cdot 10^{-7}$ hPa	$< 1 \cdot 10^{-7}$ hPa
Weight	73 kg	96 kg	72,9 kg	97,9 kg	79,9 kg	81,9 kg
Cooling method, standard	Air	Air	Air	Air	Air	Air
Turbopump	HiPace 700	HiPace 700	HiPace 700	HiPace 700	HiPace 700	HiPace 700
Backing pump	ACP 15	ACP 28	DUO 11 M	DUO 20 M	Pascal 2010	Pascal 2021

13.5.2 DN 160 CF-F

Parameter	HiCube 700 Pro	HiCube 700 Pro	HiCube 700 Pro	HiCube 700 Pro	HiCube 700 Pro	HiCube 700 Pro
Flange (in)	DN 160 CF-F	DN 160 CF-F	DN 160 CF-F	DN 160 CF-F	DN 160 CF-F	DN 160 CF-F
Flange (out)	G 1/2"	G 1/2"	G 1/2"	G 1/2"	G 1/2"	G 1/2"
Pumping speed for N ₂	685 l/s	685 l/s	685 l/s	685 l/s	685 l/s	685 l/s
Pumping speed backing pump at 50 Hz	14 m ³ /h	27 m ³ /h	9 m ³ /h	20 m ³ /h	9 m ³ /h	18 m ³ /h
Pump-down time for vacuum chamber size 10 l	17 s	8 s	23,09 s	10,33 s	20,77 s	9,83 s
Pump-down time for vacuum chamber size 100 l	169 s	84 s	230,9 s	103,3 s	207,7 s	98,3 s
Pump-down time for vacuum chamber size 1000 l	1692 s	836 s	2309 s	1033 s	2077 s	983 s
Ultimate pressure	$< 5 \cdot 10^{-10}$ hPa	$< 5 \cdot 10^{-10}$ hPa	$< 5 \cdot 10^{-10}$ hPa	$< 5 \cdot 10^{-10}$ hPa	$< 5 \cdot 10^{-10}$ hPa	$< 5 \cdot 10^{-10}$ hPa
Weight	79 kg	102 kg	78,9 kg	103,9 kg	85,9 kg	87,9 kg
Cooling method, standard	Air	Air	Air	Air	Air	Air
Turbopump	HiPace 700	HiPace 700	HiPace 700	HiPace 700	HiPace 700	HiPace 700
Backing pump	ACP 15	ACP 28	DUO 11 M	DUO 20 M	Pascal 2010	Pascal 2021

14 Dimensions

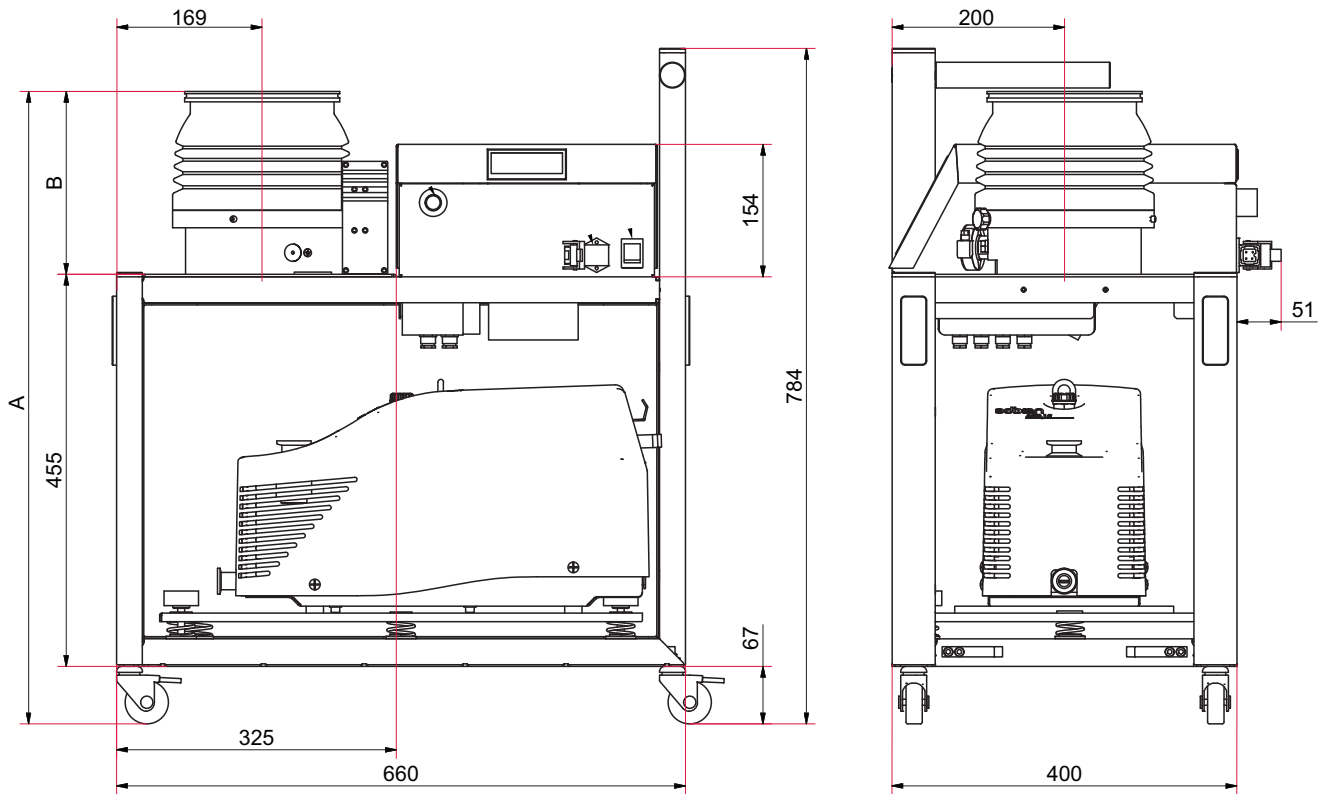

Dimensions	HiCube 80 Pro	HiCube 80 Pro	HiCube 80 Pro
Flange	DN 40 ISO-KF	DN 63 ISO-K	DN 63 CF-F
A	680 mm	671 mm	676 mm
B	158 mm	149 mm	155 mm

Dimensions	HiCube 300 Pro	HiCube 300 Pro
Flange	DN 100 ISO-K	DN 100 CF-F
A	716 mm	728 mm
B	195 mm	207 mm

Dimensions	HiCube 400 Pro	HiCube 400 Pro
Flange	DN 100 ISO-K	DN 100 CF-F
A	760 mm	760 mm
B	239 mm	239 mm

Dimensions	HiCube 700 Pro	HiCube 700 Pro
Flange	DN 160 ISO-K	DN 160 CF-F
A	733 mm	745 mm
B	212 mm	224 mm



Declaration of conformity

We hereby declare that the product cited below satisfies all relevant provisions according to the following **EC directives**:

- **Machinery 2006/42/EC (Annex II, no. 1 A)**
- **Electromagnetic Compatibility 2014/30/EU**

The agent responsible for compiling the technical documentation is Mr. Helmut Bernhardt, Pfeiffer Vacuum GmbH, Berliner Straße 43, 35614 Asslar.

HiCube
HiCube Pro

Harmonised standards and national standards and specifications which have been applied:

DIN EN ISO 12100 : 2011-03	DIN EN 61326-1 : 2013
DIN EN 1012-2 : 1996	DIN EN 62061 : 2013
DIN EN 61010-1 : 2010	Semi F47-0200
DIN EN 61000-3-2 : 2010	
DIN EN 61000-3-3 : 2009	

Signature:

Pfeiffer Vacuum GmbH
Berliner Straße 43
35614 Asslar
Germany

(Dr. Ulrich von Hülsen)
Managing Director

2016-02-26

VACUUM SOLUTIONS FROM A SINGLE SOURCE

Pfeiffer Vacuum stands for innovative and custom vacuum solutions worldwide, technological perfection, competent advice and reliable service.

COMPLETE RANGE OF PRODUCTS

From a single component to complex systems:

We are the only supplier of vacuum technology that provides a complete product portfolio.

COMPETENCE IN THEORY AND PRACTICE

Benefit from our know-how and our portfolio of training opportunities!

We support you with your plant layout and provide first-class on-site service worldwide.

Are you looking for a
perfect vacuum solution?
Please contact us:

Pfeiffer Vacuum GmbH
Headquarters • Germany
T +49 6441 802-0
info@pfeiffer-vacuum.de

www.pfeiffer-vacuum.com

PFEIFFER  **VACUUM**