



# OPERATING INSTRUCTIONS

EN

Translation of the original instructions

## **HENA 61/101**

Rotary Vane Pump

**PFEIFFER**  **VACUUM**

# Table of contents

<b>1</b>	<b>About this manual</b> .....	<b>3</b>
1.1	Validity .....	3
1.2	Conventions .....	3
<b>2</b>	<b>Safety</b> .....	<b>5</b>
2.1	Safety precautions .....	5
2.2	Protective equipment .....	6
2.3	Proper use .....	6
2.4	Improper use .....	6
<b>3</b>	<b>Transport and storage</b> .....	<b>7</b>
3.1	Transport .....	7
3.2	Storage .....	7
<b>4</b>	<b>Product description</b> .....	<b>8</b>
4.1	Product identification .....	8
4.2	Function .....	9
4.3	Range of application .....	9
<b>5</b>	<b>Installation</b> .....	<b>10</b>
5.1	Setting up the pump .....	10
5.2	Connecting the vacuum side .....	11
5.3	Connecting the exhaust side .....	11
5.4	Connecting to the mains power supply .....	12
5.5	Filling up the operating fluid .....	14
<b>6</b>	<b>Operation</b> .....	<b>15</b>
6.1	Before switching on .....	15
6.2	Switching on the pump .....	15
6.3	Pumping condensable vapours .....	16
6.4	Topping up the operating fluid .....	17
6.5	Switching off .....	18
<b>7</b>	<b>Maintenance</b> .....	<b>19</b>
7.1	Precautions .....	19
7.2	Changing the operating fluid .....	20
7.3	Changing the exhaust filter in the operating fluid separator .....	23
7.4	Cleaning the operating fluid return line .....	24
7.5	Changing the gas ballast filter .....	25
7.6	Changing the intake filter .....	26
<b>8</b>	<b>Decommissioning</b> .....	<b>27</b>
8.1	Shutting down for longer periods .....	27
8.2	Re-starting .....	27
8.3	Disposal .....	27
<b>9</b>	<b>Malfunctions</b> .....	<b>27</b>
9.1	Rectifying malfunctions .....	28
<b>10</b>	<b>Service</b> .....	<b>29</b>
<b>11</b>	<b>Spare parts</b> .....	<b>30</b>
11.1	Spare parts packages .....	31
<b>12</b>	<b>Accessories</b> .....	<b>31</b>
<b>13</b>	<b>Technical data and dimensions</b> .....	<b>32</b>
13.1	General .....	32
13.2	Technical data .....	33

13.3 Dimensions . . . . . 34  
**Declaration of conformity . . . . . 36**

# 1 About this manual

## 1.1 Validity

This operating manual is for customers of Pfeiffer Vacuum. It describes the functioning of the designated product and provides the most important information for safe use of the unit. The description follows applicable EU guidelines. All information provided in this operating manual refers to the current state of the product's development. The documentation remains valid as long as the customer does not make any changes to the product. Up-to-date operating instructions can also be downloaded from [www.pfeiffer-vacuum.com](http://www.pfeiffer-vacuum.com).

### Applicable documents

<b>Hena 61/101</b>	<b>Operating instructions</b>
Declaration of Conformity	Part of this document
Operating instructions for accessories (order-specifically)	see section "accessories"

\*also available via [www.pfeiffer-vacuum.com](http://www.pfeiffer-vacuum.com)

## 1.2 Conventions

### Safety instructions

The safety instructions in Pfeiffer Vacuum operating instructions are the result of risk evaluations and hazard analyses and are oriented on international certification standards as specified by UL, CSA, ANSI Z-535, SEMI S1, ISO 3864 and DIN 4844. In this document, the following hazard levels and information are considered:

<b>DANGER</b>
<b>Imminent danger</b> Indicates an imminent hazardous situation that will result in death or serious injury.
<b>WARNING</b>
<b>Possibly imminent danger</b> Indicates an imminent hazardous situation that can result in death or serious injury.
<b>CAUTION</b>
<b>Possibly imminent danger</b> Indicates an imminent hazardous situation that can result in minor or moderate injury.
<b>NOTICE</b>
<b>Command or note</b> Command to perform an action or information about properties, the disregarding of which may result in damage to the product.

## Pictographs



Prohibition of an action to avoid any risk of accidents, the disregarding of which may result in serious accidents



Warning of a displayed source of danger in connection with operation of the unit or equipment



Command to perform an action or task associated with a source of danger, the disregarding of which may result in serious accidents

## Instructions in the text

→ Work instruction: here you have to do something.

## Symbols used

The following symbols are used consistently throughout in all illustrations:

- ⓪ Vacuum flange
- Ⓛ Exhaust flange
- Ⓜ Gas ballast valve
- Ⓧ Power connection

## 2 Safety

### 2.1 Safety precautions



#### **Duty to inform**

Each person involved in the installation, operation or maintenance of the vacuum pump must read and observe the safety-related parts of these operating instructions.

→ The operator is obligated to make operating personnel aware of dangers originating from the vacuum pump, the pumped medium and the entire system.



#### **Installation and operation of accessories**

Pfeiffer Vacuum pumps can be equipped with a series of adapted accessories. The installation, operation and maintenance of connected devices are described in detail in the operating instructions of the individual components.

→ For information on order numbers of components, see "Accessories".

→ Use original accessory parts only.

- Do not expose any body parts to the vacuum.
- Observe the safety and accident prevention regulations.
- Check regularly that all safety precautions are being complied with.
- Do not carry out any unauthorised modifications or conversions to the pumps.
- Depending on the operating and ambient conditions, the surface temperature of the pumps may rise above 70 °C. Use suitable finger guards if necessary.
- When returning the pumps to us please note the instructions in the Service section.

## 2.2 Protective equipment

Determined situations concerning the handling of vacuum pumps require wearing of personal protective equipment. The owner, respectively the employer are obligated to provide an adequate equipment to any operating persons.



### DANGER

#### Danger to health by hazardous substances during maintenance or installation

Depending on the process vacuum pumps, components or operating fluids can be contaminated by toxic, reactive or radioactive substances.

→ Wear adequate protective equipment during maintenance and repairs or in case of reinstallation.

### CAUTION

#### Risk of injury through hot surfaces

Vacuum pumps can become hot during operation.

→ Allow the pump to cool before maintenance and repairs.

→ If necessary wear protective gloves according to EN 420.

### CAUTION

#### Increased noise emission!

Increased noise emission can occur within a limited area surrounding the vacuum pump.

→ Provide noise protection or

→ wear hearing protection.

## 2.3 Proper use



### NOTICE

#### EC conformity

The manufacturer's declaration of conformity becomes invalid if the operator modifies the original product or installs additional components.

→ Following installation into a plant and before commissioning, the operator must check the entire system for compliance with the valid EU directives and reassess it accordingly.

- The vacuum pump may only be used to generate a vacuum.
- Only use the vacuum pump for applications with oxygen concentration  $\leq 21\%$ .
- Installation, operating and maintenance regulations must be complied with.
- Other accessories, than those described in this manual, must not be used without the agreement of Pfeiffer Vacuum.

## 2.4 Improper use

Improper use will cause all claims for liability and warranties to be forfeited. Improper use is defined as usage for purposes deviating from those mentioned above, especially:

- pumping of corrosive gases
- pumping of explosive media
- operation in potentially explosive areas
- pumping of gases containing impurities such as particles, dusts and condensate; note the vapour compatibility levels of the pump
- pumping of substances that tend to sublime
- use of the vacuum pump to generate pressure

- pumping of liquids
- the use of operating fluids not specified by Pfeiffer Vacuum
- connection to pumps or units which are not suitable for this purpose according to their operating instructions
- connection to units which have exposed voltage-carrying parts
- operation of the devices in areas with ionizing radiation

## 3 Transport and storage

### 3.1 Transport



#### WARNING

##### **Danger from falling and swinging loads!**

When lifting the pump there is a danger of falling parts.

- Make sure that there are no persons under the suspended load.
- Close off and supervise the area under the pump.



#### CAUTION

##### **Operating fluid overflows into the pump system if the pump is tilted!**

Vane fractures when pump starts up.

- Only transport pump without operating fluid.

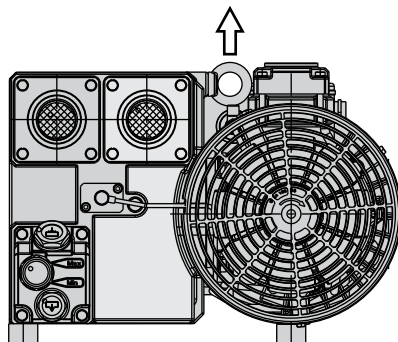

Fig. 1: Unpack and lift pump

- Look for transportation damage when receiving the pump.
- Use only a forklift to transport pump packed on pallet.
- Unpack pump and undo screws on transport container.
- Reuse the transport container of the vacuum pump.
  - Transport or ship vacuum pumps in the original packing preferably.

#### Transport without packaging

- Remove the locking cap from the vacuum and exhaust flange immediately before connecting!
- Use only the eye bolt on the top side of the pump to lift the pump.
- To lift the pump without motor and if accessories are mounted, fit another strap at a suitable position.

### 3.2 Storage

- Check that all the openings on the pump are securely closed.
- Fill up the pump with new operating fluid to the top edge of the sight glass.

- ➔ Store the pump only dry and dust-free indoors within the specified environmental conditions.
  - In rooms with moist or aggressive atmospheres, the pump must be airproof shrink-wrapped in a plastic bag together with a bag of desiccant.
  - After storage periods longer than two years, it is recommended to carry out maintenance and change the operating fluid before using the pump.

## 4 Product description

### 4.1 Product identification

To correctly identify the product when communicating with Pfeiffer Vacuum, always have the information from the rating plate available and use it:

- Pump model and model number
- Serial number
- Type and amount of operating fluid
- Date of manufacture

Please find the voltage range and motor-related data on the separately attached motor rating plate.

#### Scope of delivery

- Pump with drive unit
- Operating fluid (except F4 and F5)
- Operating instructions

#### Pump types

Pump type	Pump designs
Hena 61	Pump in standard version <ul style="list-style-type: none"> <li>• Vacuum connection and gas outlet: G 1 1/4"</li> <li>• Operating fluid return via float valve</li> <li>• Gas ballast device without shut-off valve</li> </ul>
Hena 101	Pump in standard version <ul style="list-style-type: none"> <li>• Vacuum connection and gas outlet: G 1 1/4"</li> <li>• Operating fluid return via float valve</li> <li>• Gas ballast device without shut-off valve</li> </ul>



## 4.2 Function

The HenaLine™ series pumps are oil-sealed, single stage operating rotary vane pumps with air cooling and circulatory lubrication. A vacuum safety valve in the intake flange closes the intake line automatically and prevents operating fluid back-streaming when the pump is switched off. An integrated oil mist filter cleans the pumped gas and prevents the expulsion of operating fluid mist at the exhaust. The operating fluid, collected in the separator, is fed back to the pump. In addition there is a filter mounted at the operating fluid separator, which cleans the operating fluid.

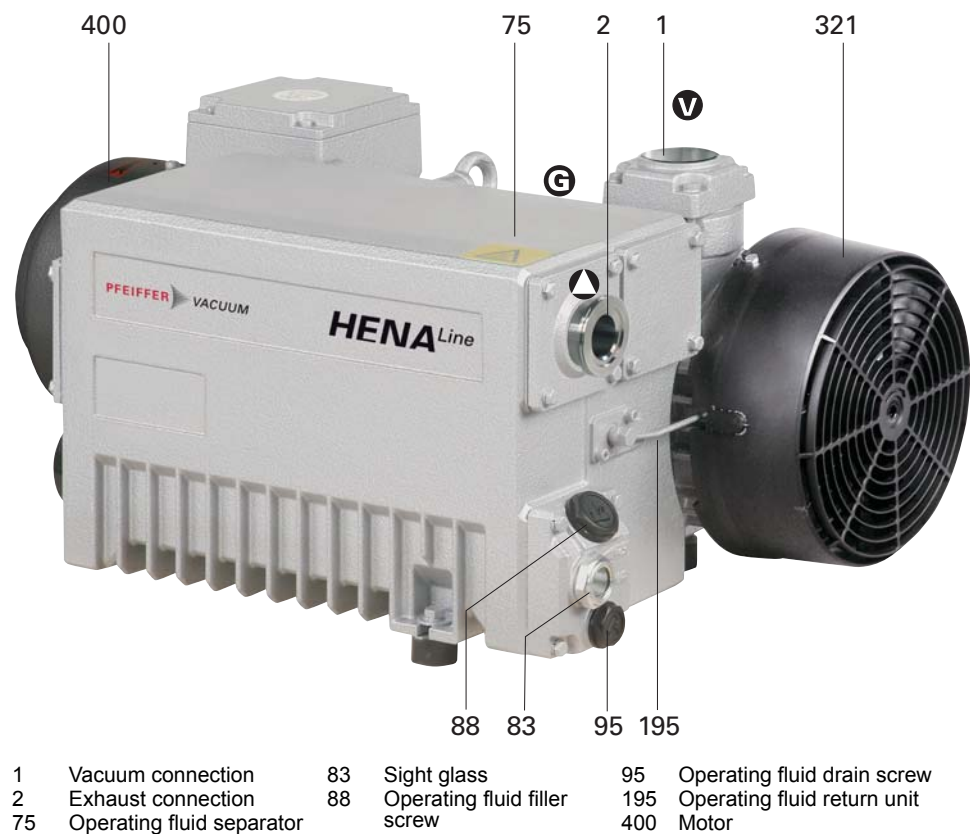

Fig. 2: Hena 61/101

### Oil circulation

The vacuum pump requires operating fluid for sealing the gap, for lubrication and for cooling. The operating fluid reservoir is on the pressure side of the vacuum pump on the floor of the operating fluid separator. The pressure differential between the pressure side and suction side automatically causes operating fluid to be sucked in over the supply lines from the operating fluid separator and feed into the pumping system. The incoming operating fluid, together with the incoming gas, is pumped through the vacuum pump and exhausted into the operating fluid separator as oil mist. Operating fluid that is separated at the exhaust filters collects in the upper part of operating fluid separator 75 and is returned via operating fluid return line directly to the intake side.

### Cooling

The vacuum pump is cooled by heat radiation from the surface of the vacuum pump, the air flow of the two fan impellers, and by the pumped gas.

## 4.3 Range of application

The vacuum pump is intended for the evacuation of air or other non-aggressive, non-poisonous and non-explosive gases. Pumping media with a higher density than air results in a higher thermal and mechanical load on the vacuum pump and the drive, and is only permitted after prior consultation with Pfeiffer Vacuum.

## 5 Installation

### 5.1 Setting up the pump

#### Installation location

Observe the following requirements when setting up the pump:

- Consider the load-bearing capacity of the installation site.
  - Maximum installation altitude 1000 m (above mean sea level)
  - Permissible ambient temperature: +12 ... 40 °C
  - Maximum relative humidity 95%
- Fill up with operating fluid before operating the first time (see p. 14, chap. 5.5).
- Amount and type according to rating plate
- Always place the pump on a firm, even surface.
- Where stationary installation is involved, anchor the pump on site.
- When installing the pump in a closed housing, ensure there is sufficient air circulation.
- Sight glass and gas ballast valve must be visible and readily accessible.
  - Voltage and frequency information given on the motor rating plate must be visible.

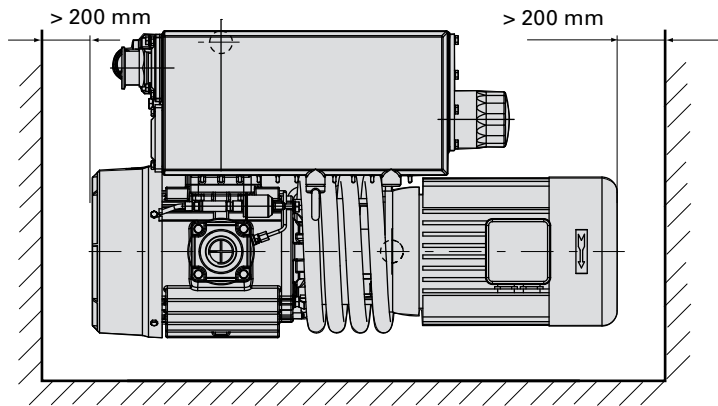

Fig. 3: Setting up the pump

## 5.2 Connecting the vacuum side

- Remove the locking cap from the vacuum connection.
- Clean the connection thread and seal it with Loctite 245 or 577 before mounting.
- The connection between the pump and the recipient should be kept as short as possible.
  - Depending on the design, use PVC hoses or pipes with a threaded G 1 1/4" or flanged connection (accessories).
  - Separators, filters etc. may be installed upstream to protect the pump (see accessories). However, please observe the loss of pumping capacity due to the conductivity of the accessories.

## 5.3 Connecting the exhaust side



### CAUTION

#### High pressure in the exhaust line!

Risk of damage to the seals and risk of pump bursting.

- Always use lines without shut-off devices on the exhaust side.
- Do not use overpressure or underpressure - maintain atmospheric pressure.



### WARNING

#### Emission of toxic substances from the exhaust!

Danger of poisoning from emitted gases or vapours, which can be detrimental to health and/or can pollute the environment, depending on the particular application.

- Comply with the applicable regulations when working with toxic substances.
- Only officially approved filter systems may be used to separate and remove these substances.

- Choose the cross-section of the exhaust line to be at least the size of the nominal connection diameter of the vacuum pump's exhaust connection.
- Clean the connection thread and seal it with Loctite 245 or 577 before mounting.
- Piping to the pump must be suspended or supported.
  - Physical forces from the piping system must not be allowed to act on vacuum pumps.
- Lay piping from the pump sloping downward so that no condensate can flow back into the pump; otherwise fit a condensate separator.
  - If an air trap is created in the system, then a device for draining condensation water must be provided at the lowest point.

## 5.4 Connecting to the mains power supply

Depending on the pump type, different motor versions or mains voltages are possible:

- Three-phase motor without motor protection.



<b>DANGER</b>
<p><b>Voltage-bearing elements</b>                      Danger to life from electric shock.</p> <p>→ The electrical connection can be carried out only by trained and authorised electricians.</p> <p>→ Disconnect the power supply and secure it against being switched back on.</p> <p>→ Ensure the system is adequately earthed.</p>



<b>NOTICE</b>
<p><b>Excess voltage!</b>                      Danger of destroying the motor.</p> <p>→ Power connections must comply with local regulations. Voltage and frequency information given on the motor rating plate must correspond to the mains voltage and frequency values.</p> <p>→ To protect the motor and supply cable in case of malfunction, mains fuse protection must be implemented. Recommended: Type K slow blow circuit breaker.</p>



<b>WARNING</b>
<p><b>Danger of injury from moving parts!</b>                      After power failure or motor shutdown due to overheating, the motor may restart automatically.</p> <p>→ Secure the motor so that it cannot be switched on while any work is being performed on the pump.</p> <p>→ If necessary, dismantle the pump from the installation for inspection.</p>

### Three-phase motor

#### The three-phase current motor circuit

##### Star Connection

The ends of the three coils are connected at the star center. The terminal voltage is the cube root of the coil voltage; the mains and the coil current are the same. Star connections are denoted by the symbol  $\text{Y}$ . A star connection three phase motor for 400 V mains voltage has a coil voltage of 230 V.

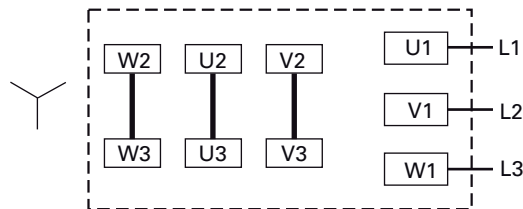

Fig. 4: Motor coil and connecting plate for high voltage

##### Double Star Connection

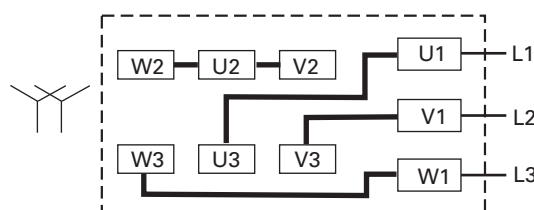

Fig. 5: Connecting plate for low voltage



### NOTICE

**Do not start with star/delta connection.**

→ Always start motor directly.

#### Checking the direction of rotation

The control of the direction of rotation is required for pumps with three-phase motors!



### CAUTION

**Operating fluids may leak out!**

If the direction of rotation is incorrect, there is a danger that operating fluids may leak at the vacuum flange.

→ Always check the direction of rotation before filling in operating fluid.

→ Remove the locking cap from the exhaust flange.

→ Switch the pump on briefly (from 2 to 3 sec.).

- Rotation must be in a clockwise direction in view of the shaft end of the motor (see the arrow on the fan cover).

→ If the direction of rotation is incorrect: Swap two phase contacts at the connecting cable.

→ Fill up the operating fluid.

## Motor protection

### With motor protection switch

Suitable are protection switches with slow triggering characteristics. The drive motor can have a power consumption that is higher than the rated current  $I_N$ . According to DIN EN 60034-1 it is permissible to exceed the rated current  $I_N$  1.5 times for a period of 2 minutes. The setting must permit the overload ability of the motor and can be found in the following table.

#### Hena 61

Voltage [V]	Frequency [Hz]	Motor rating [kW]	$I_N$ [A]	$I_{max}$ [A]
190 ... 208	50	2,0	9,4	79
380 ... 415	50	2,0	4,7	40
220 ... 230	60	2,4	9,4	79
440 ... 460	60	2,4	4,7	40

#### Hena 101

Voltage [V]	Frequency [Hz]	Motor rating [kW]	$I_N$ [A]	$I_{max}$ [A]
190 ... 208	50	2,7	11,8	99
380 ... 415	50	2,7	5,9	50
220 ... 230	60	3,4	12,4	102
440 ... 460	60	3,4	6,2	51

## Motor control system

### Frequency converter (valid for three phase motors)

Operation of rotary vane pumps with variable rotation speeds is possible in the mains frequency range between 35 and 60 Hz. The start-up can use a ramp (run-up time: max. 30 s); the shutdown can occur directly.

## 5.5 Filling up the operating fluid

The type and amount of operating fluid should be visible on the pump's rating plate for every rotary vane pump.

The delivery consignment for the **standard pump** contains sufficient operating fluid for one filling. The use of other operating fluids requires prior authorisation from Pfeiffer Vacuum.

### Permissible operating fluid

- P3 (standard operating fluid)
- Operating fluid for special applications on request



### NOTICE

#### Use approved operating fluids only!

The use of operating fluids that have not been approved by Pfeiffer Vacuum shall result in a limited warranty. In such cases, it is not possible to guarantee that product-specific performance data will be achieved.

→ Prior consultation is required before using other application-specific operating fluids.

### Filling up the operating fluid

- Unscrew operating fluid filler screw 88.
- Fill up with operating fluid to the middle of the sight glass.
  - Filling quantity approx. 2,0 l of operating fluid.

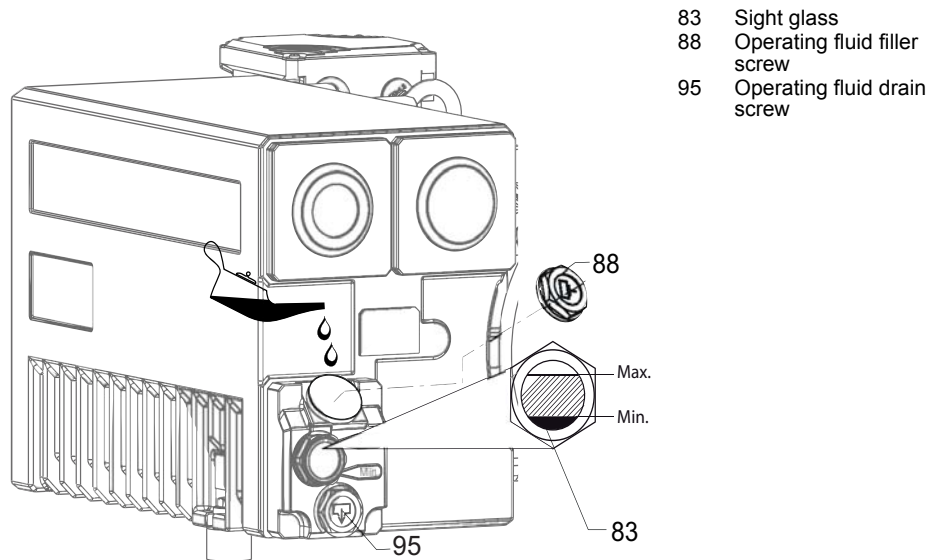

Fig. 6: Filling up the operating fluid

- Screw in operating fluid filler screw 88.
- Close intake port valve (if present) or cover intake flange.
- Start pump and run it for max. 5 minutes.
- Switch off pump and wait until the operating fluid has collected in the separator box.
- Check fill level: The correct fill level is between the markings on the sight glass.
  - If the fill level drops below the "Min" marking, add operating fluid.
- Open intake port valve.

## 6 Operation

### 6.1 Before switching on

- Check the operating fluid level in the sight glass.
- Compare the voltage and frequency information on the rating plate with the mains voltage and frequency values.
- Check that exhaust connection is free flowing (atmospheric pressure).
- Protect the pump sufficiently from taking in contaminants by means of suitable precautions (e.g. dust filters); if necessary, check operating fluid regularly or replace at shorter intervals.

### 6.2 Switching on the pump

The pump can be switched on in any pressure range between atmospheric and ultimate pressure.

The ideal operating condition of the pump is achieved during continuous operation. Cyclic operation is possible, but 10 cycles per hour should not be exceeded and the operating phase should always be longer than the downtime (non-operation time).

No specific measures are required when pumping dry gases. Due to the permanently opened gas ballast unit, the final pressure that can be achieved by the pump is limited. To achieve the lowest possible final pressures, you can mount a manual gas ballast valve (accessories) to close off the system (see p. 16, chap. 6.3).



#### WARNING

##### **Danger of burns from exiting hot oil mist!**

During operation, the operating fluid separator is filled with hot, pressurised oil mist.

- Only operate the vacuum pump with the operating fluid filler screw securely fitted.
- Open the blanking plugs on the separator only when the pump is switched off.



#### CAUTION

##### **Hot surface!**

Danger of burns if hot parts are touched. Depending on the operating and ambient conditions, the surface temperature of the pump may rise above 70 °C.

- In this case, use suitable finger guards.



#### NOTICE

##### **Increased motor current draw (> rated current) !**

With an intake pressure of about 300 hPa, the pump has the highest power requirement, which can increase even further under unfavorable operating conditions (e.g. counter-pressure on exhaust side).

- Limit the max. power consumption for 1.5 times the rated current for 2 minutes max. (according to DIN EN 60034-1).

- Switch on the pump with the vacuum flange closed and allow to warm up for 30 minutes.

#### Permissible operating conditions

Type / Version	Intake pressure for continuous operation	Intake pressure for intermittent operation
Hena 61/101 Operating fluid return via float valve	< 800 hPa unlimited	< 800 hPa unlimited

**Operating fluid return via float valve**

The pumps are fitted with an operating fluid return as standard. If the operating fluid collected in the operating fluid separator 75 reaches a definite level, the float valve opens and the ejected operating fluid is returned to the pump's intake flange.



**NOTICE**

The operating fluid return only works properly if the working pressure is < 800 hPa.

**6.3 Pumping condensable vapours**

Should the process gases contain condensable gases, the rotary vane pump must be operated with gas ballast (i.e. with an open gas ballast valve).



**NOTICE**

**Bad final vacuum and damage to the pump!**  
 Danger of condensation and corrosion due to exceeding the water vapour compatibility during operation without gas ballast or in case of insufficient supply of flushing gas.

- Only pump vapours when the pump is warm and the gas ballast valve is open.
- When the process has been completed, allow the pump to continue running for about 30 minutes with the vacuum flange closed and the gas ballast open for operating fluid regeneration purposes.

**Gas ballast function**

The pumps have a gas ballast unit via which air is permanently taken in. A ball valve 440 for closing off the line can be fitted as an upgrade (see accessories).

The gas ballast valve is closed when turning to the right to position 0 and open when turning to the left to position 1. Intermediate settings are not possible.

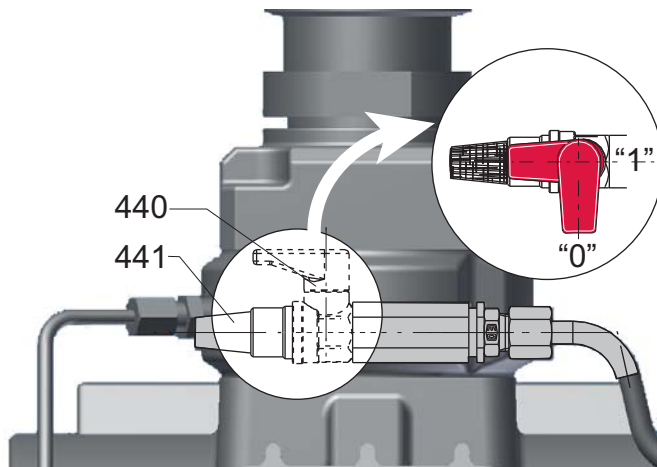

**Fig. 7: Gas ballast valve**

440 Ball valve

441 Sintered metal filter



## 6.4 Topping up the operating fluid

If the operating fluid has reached its minimum filling level, the operating fluid must be topped up.

### Filling up the operating fluid

- Switch off the pump.
- Unscrew operating fluid filler screw 88.
- When the pump is at operation temperature, top up the operating fluid up to the "max." marking.

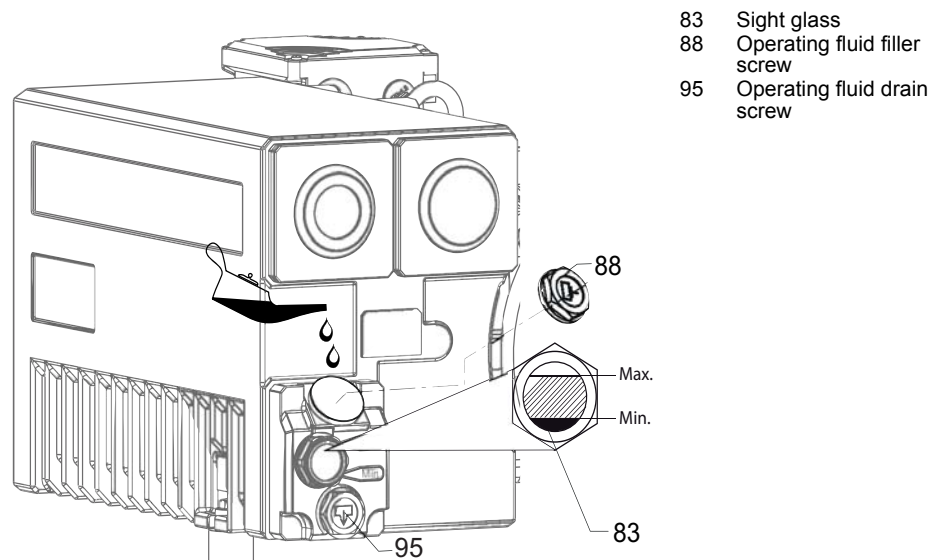

**Fig. 8: Filling up the operating fluid**

- Screw in operating fluid filler screw 88.

## 6.5 Switching off

The pump can be switched off in any pressure range.

HenaLine rotary vane pumps have an integrated non-return valve on the suction side. This closes automatically when the pump is switched off and therefore prevents the return flow of gas and processing materials into the suction pipe.

- Switch the pump off at the mains switch or disconnect from the mains in a secure manner.

### Vacuum chamber venting



#### NOTICE

##### **Danger of backflow of operating fluid into the intake line!**

Contamination of the connected vacuum system!

- Vent the vacuum chamber within 30 s, regardless of the chamber size.
- For a longer venting process, use an additional shut-off valve and shut off the intake line after switching off the pump.

### Maintaining the vacuum in the chamber



#### NOTICE

##### **Danger of backflow of operating fluid into the intake line!**

Contamination of the connected vacuum system!

- Because the safety valve of the pump is not suitable for longer-term sealing, install an additional shut-off valve in the intake line.
- Shut off the intake line immediately after switching off the pump.

## 7 Maintenance

### 7.1 Precautions



#### WARNING

##### **Danger of injury from moving parts!**

After power failure or motor shutdown due to overheating, the motor may restart automatically.

- Secure the motor so that it cannot be switched on while any work is being performed on the pump.
- If necessary, dismantle the pump from the installation for inspection.



#### WARNING

##### **Pump parts may be contaminated from pumped media!**

Danger of poisoning due to contact with harmful substances.

- Decontaminate the pump before carrying out any maintenance work.
- In the event of contamination, take suitable safety precautions to prevent your health from being harmed by any dangerous substances.
- Turn off the vacuum pump, vent to atmospheric pressure and allow to cool.
- Disconnect the drive motor from the mains and secure it so that it cannot be switched on.
- Only dismantle the pump as far as necessary to carry out maintenance.
- Dispose of used operating fluid in compliance with local regulations.
- When using synthetic operating fluids or working with toxic substances or substances contaminated with corrosive gases, the relevant instructions governing their use must be observed.
- Use only alcohol or similar agents for cleaning pump parts.

**Checklist for inspection, maintenance and overhaul**

Certain maintenance and overhaul work should only be performed by Pfeiffer Vacuum Service (PV). Pfeiffer Vacuum will be released from all warranty and liability claims if the required, below listed, intervals are exceeded or maintenance or overhaul procedures are not performed properly. This also applies if replacement parts other than Pfeiffer Vacuum OEM replacement parts are used.

Activity	daily	as required; at least once every 6 months	as required; at least annually	as required; at least every 2 years	as required; at least every 4 years
Check operating fluid level	X				
Visual inspection (leak-tightness/oil leaks)	X				
Check the saturation of the exhaust air filter (internal oil mist filter)	X				
Change operating fluid		X			
Change operating fluid filter		X			
Change the exhaust air filter			X		
Cleaning the pump and renew the O-rings			X		
Clean gas ballast filter		X			
Clean the fan cap of the motor		X			
Replace the radial shaft seals <sup>1</sup>				X (PV)	
Clean or replace discharge valves				X (PV)	
Replace vanes					X (PV)
Replace the non return valve					X (PV)
Check or change coupling					X (PV)

Depending on the process, the required replacement intervals for lubricants and the intervals for inspection, maintenance and overhaul may be shorter than the guide values specified in the table. Consult with Pfeiffer Vacuum Service if necessary.

1. Where unusually high levels of operating fluid are being lost it is necessary to carry out a check of the radial shaft seals. If operating fluid leaks out from under the pump between the pump casing and the motor or fan, the radial shaft seals should be replaced. In this case please get in touch with your local Pfeiffer Vacuum Service.

**7.2 Changing the operating fluid**

The service life of the operating fluid is dependent on the application area for the pump. It must be changed if:

- The specified ultimate pressure is no longer reached
- The operating fluid in the sight glass is visibly contaminated, milky, or cloudy
- The operating fluid is thermally aged, identifiable by its color ID value (applies to mineral oils only).



**Depending on the applications, Pfeiffer Vacuum recommends determining the exact service life of the operating fluid during the first year of operation.**

The replacement interval may vary from the guide value specified by Pfeiffer Vacuum depending on the thermal and chemical loads, and the accumulation of suspended particles and condensation in the operating fluid.



**WARNING**

**Hot operating fluid!**

Danger of burns when draining due to contact with skin.

- Wear suitable protective clothing.
- Use a suitable collecting vessel.

**WARNING****Operating fluid may contain toxic substances from the pumped media!**

Danger of poisoning from the emission of harmful substances from the operating fluid.

- Wear suitable protective clothing and respirators.
- Dispose of operating fluid according to the local regulations

**Request safety data sheets for operating fluids and lubricants**

from Pfeiffer Vacuum or download at [www.pfeiffer-vacuum.com](http://www.pfeiffer-vacuum.com).

- Dispose of operating fluid according to the local regulations.

**Draining the operating fluid**

- Turn off the vacuum pump and vent to atmospheric pressure.
- Unscrew operating fluid filler screw 88.
- Place a collecting vessel under the drain hole.
- Unscrew operating fluid drain screw 95.
- Drain the operating fluid while still quite hot;
  - to empty the pump fully, tip it forward slightly.

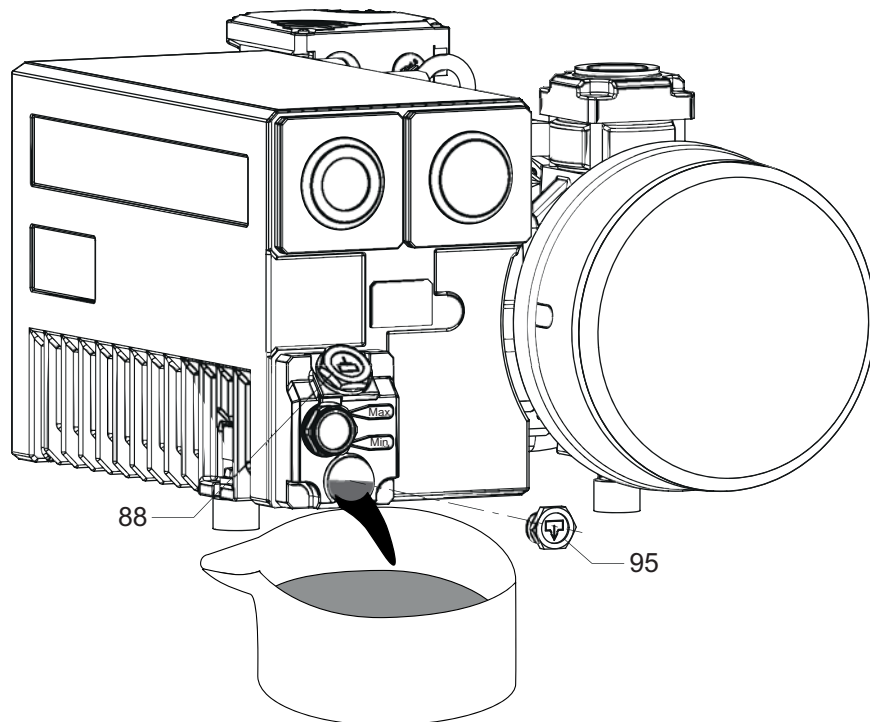

**Fig. 9: Draining the operating fluid**

- Screw in operating fluid drain screw 95; pay attention to O-ring.
- Screw in operating fluid filler screw 88.
- Allow pump to run for a maximum of 5 seconds with the vacuum flange open.
- Drain off remaining operating fluid.
  - In case of serious contamination, the operating fluid will have to be changed several times (flushing).
- Screw in operating fluid drain screw 95; pay attention to O-ring.
- Fill up with operating fluid and check the filling level (see p. 14, chap. 5.5).
- Screw in operating fluid filler screw 88.

**Determining the level of deterioration**

- The level of deterioration of operating fluid P3 can be determined for clean processes with the colour scale (in accordance with DIN 51578); supplementary sheet PK 0219 BN on request or at [www.pfeiffer-vacuum.com](http://www.pfeiffer-vacuum.com).

- Suck off operating fluid from the pump through the operating fluid filler opening.
- Fill the specimen in a test tube or some similar vessel and test by holding against the light.
- Where discolouration is red brown (equivalent to 5 on the scale) change operating fluid at the latest.

### Flushing and cleaning

If the interior of the pump is heavily contaminated with process residues, we recommend performing several changes of operating fluid to flush away the contamination:

- Operate the pump with the gas ballast open until the pump has warmed up.
- Drain the operating fluid again and check for contamination, flush again if necessary.
- If the operating fluid is heavily contaminated, replace the operating fluid filter 100 and exhaust filter 122.
- Screw the operating fluid drain screw back in.
- Fill up with operating fluid and check the filling level .
- Screw in operating fluid filler screw 88.

### Changing the operating fluid filter

Operating fluid filter 100 should be replaced at every operating fluid change but at least once every six months. It is also necessary to replace the filter when the pump is on operating temperature and the filter housing is cold.

- Allow the pump to warm up for a minimum of 15 minutes before replacing the filter.
- Switch off the pump.
- Drain off operating fluid.
- Unscrew operating fluid filter with a spanner and replace.
- Oil the sealed surface of the replacement filter before fitting.
- Screw in the filter manually; do not use tools.

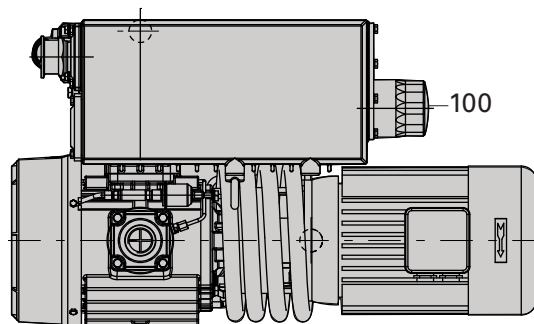

Fig. 10: Changing the operating fluid filter 100

## 7.3 Changing the exhaust filter in the operating fluid separator

Exhaust filters 122 in operating fluid separator 75 should be replaced, depending on the application and level of contamination, however at least once every year. It is recommended to replace also the respective O-rings 121.

During operation, the exhaust filters become saturated with oil. It is therefore normal for the operating fluid fill level to sink slightly after the filters are changed.

### Indications that a filter change is required:

- High current drain by the motor.
- Increased presence of operating fluid vapor in gas outlet.
- Increased pressure in operating fluid separator 75 (manometer display in red range).  
To perform continuous monitoring of the filter resistance, you can install a manometer (see accessories) instead of the operating fluid filler screw 88.



### WARNING

#### Exhaust air filter may contain toxic substances from the pumped media!

Danger of poisoning from the emission of harmful substances (radioactive, toxic, etc.) from the filter and the operating fluid.

- Wear suitable protective clothing and respirators.
- Dispose of consumables supplies according to the local regulations

## Dismantling

Depending on the pump type, between one and eight exhaust filters are used. The process for changing a filter is described below using an exhaust filter as an example.

- Remove exhaust line.
- Unscrew screws 146 from separator cover 155; take care with the spring washer !
- Remove separator cover 155, observe the flat gasket 141.
- Slacken screws 126 and release tension on filter spring 125; do not remove screws.

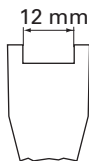

### NOTICE

#### Make a tool!

To simplify dismantling/assembly of the filter springs, we recommend that you make a tool.

- Make a fork out of steel sheet about 2 mm thick as shown in the sketch.
- Weld the lower end of the fork onto the tip of a medium-sized slotted screwdriver.
- Using the tool, press filter spring 125 out of the recesses and twist.
- Remove filter spring.
- Remove used exhaust filter 122 from operating fluid separator; be careful of O-rings 121.

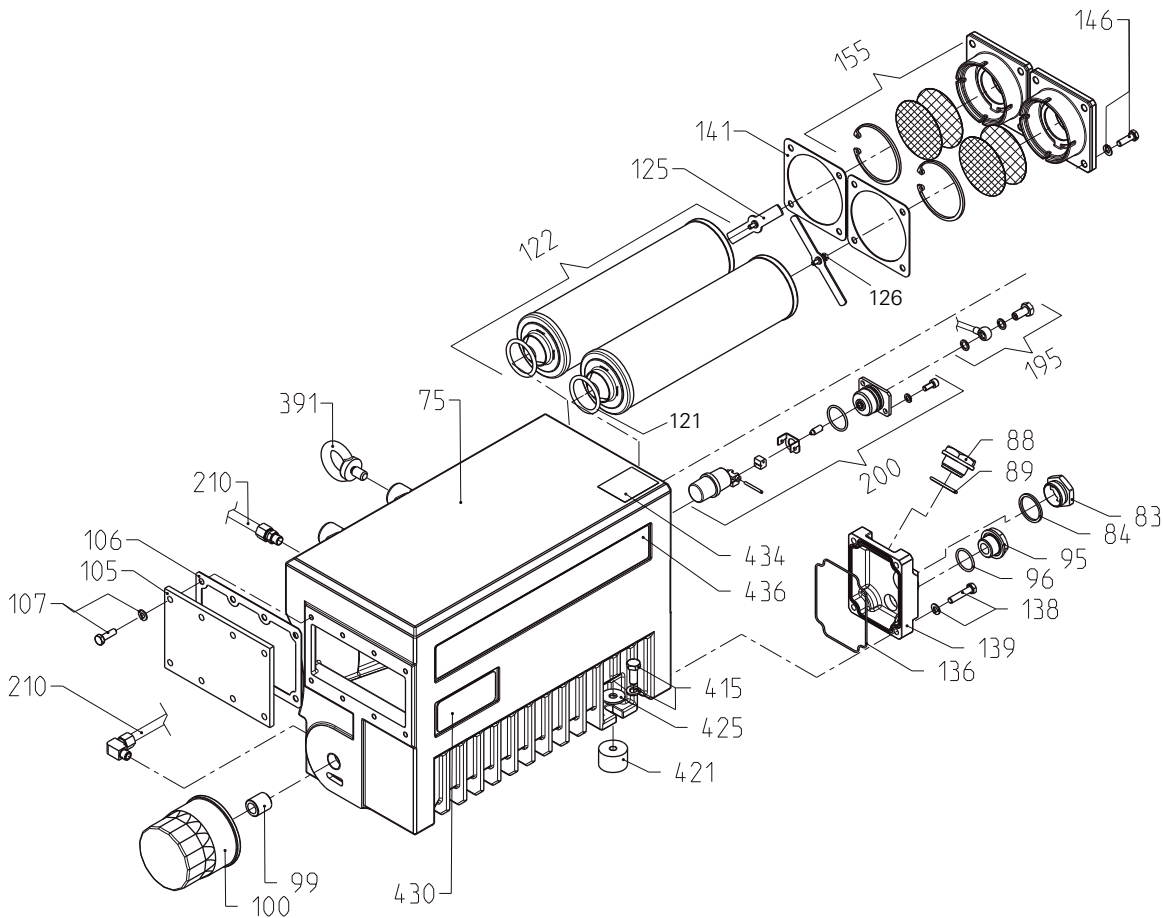

75	Operating fluid separator	95	Operating fluid drain screw	125	Filter spring
83	Sight glass	96	O-ring	146	Hexagon head screw/spring lock washer
84	Flat seal	100	Operating fluid filter	155	Separator cover
88	Operating fluid filler screw	122	Exhaust filter with O-ring	195	Operating fluid return line
89	O-ring	121	O-ring	200	Float valve, complete

**Fig. 11: Changing the exhaust filter**

**Assembly**

- ➔ **Assembling** is carried out in reverse order.
- ➔ Insert new exhaust filter; be careful of O-ring.
- ➔ Check seat of screw in the filter spring; tip of screw must project approx. 2 to 5 turns of the thread beyond the filter spring.
- ➔ Using tool, insert filter spring into operating fluid separator and engage in the location in the separator box; at the same time, insert the screw into the hole of the exhaust filter.
- ➔ Tighten screw 126 in the filter screw until the screw head is in contact with the spring washer.
- ➔ Check the sieve in the separator cover; clean if necessary.
- ➔ Install separator cover 155, ensure that flat seal 141 is clean and undamaged; exchange if necessary.

**7.4 Cleaning the operating fluid return line**

To ensure proper functioning, the operating fluid return line 195 and the float valve should be cleaned whenever the exhaust filter and the operating fluid is replaced.

This ensures that the vacuum pump achieves the specified ultimate pressure and no operating fluid leaks out at the exhaust flange.

- ➔ Remove separator cover 155 above the float valve 200 (fig. see above).



- Using a spray bottle, evacuate operating fluid from the float chamber.
- Slacken screws in the ventilator cowl if necessary, and remove ventilator cowl 340.



#### Operating fluid leaks out

When the banjo fitting is released, a small amount of operating fluid leaks out.

- Have a cleaning cloth to hand.
  - Pay attention to the sealing rings of the banjo fitting.
- Release banjo fitting of operating fluid return line 195 from the operating fluid separator and bend the line to the side.
  - Slacken screws on the flange of float valve 200 and remove float valve from the operating fluid separator.
  - Check float valve for cleanliness and functioning, blow out with compressed air if necessary.
  - Ensure that the O-ring on the flange of the float valve is present and undamaged, replace with a new O-ring if necessary.
  - Insert float valve into the operating fluid separator with the correct orientation and screw on the two screws on the flange.
  - Fasten banjo fitting of operating fluid return line on the operating fluid separator with the banjo bolt and two sealing rings.
  - Re-install ventilator cowl and fasten with screws.
  - Operate the pump and check the integrity of the operating fluid return by monitoring the final pressure.

## 7.5 Changing the gas ballast filter

The gas ballast filter is used to keep the air free of particles before entering the suction chamber.

The greater the contamination, the lower the filter air throughput and the greater the risk of condensation and corrosion within the pump.

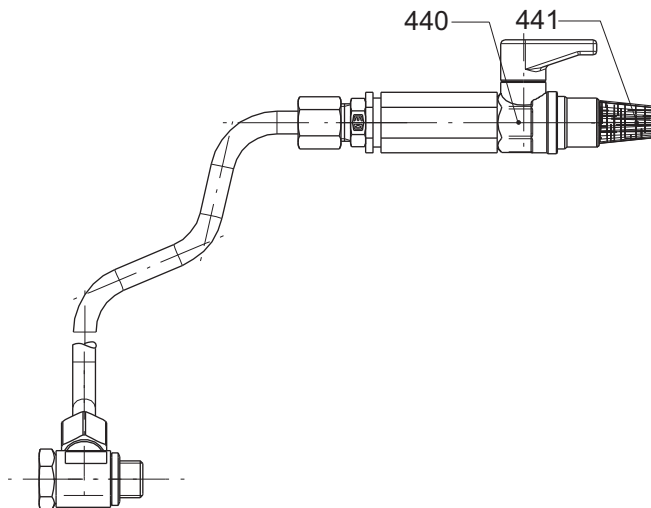

Fig. 12: Gas ballast valve 440 with gas ballast filter 441

- Remove gas ballast filter 441.
- Clean the gas ballast filter 441 using alcohol and blow out using compressed air.

## 7.6 Changing the intake filter

The intake filter, located in the upper part of the intake flange must be cleaned when the intake throughput reduces.

- Dismantle operating fluid return line from the intake flange.
- Unscrew screws 265 from the vacuum flange and dismantle flange
- Remove intake sieve 261 from the intake port and clean it.
- When cleaning the sieve it is recommended to clean the intake valve at the same time and check it for wear and tear.

## 8 Decommissioning

### 8.1 Shutting down for longer periods

Before shutting down the pump, observe the following procedure and adequately protect the pump system against corrosion:

- Switch off the pump.
- Change the operating fluid (see p. 20, chap. 7.2).
- Start the pump and allow the pump to warm up with closed vacuum flange and with open gas ballast valve.
- Close gas ballast valve.

### 8.2 Re-starting



#### Emission of operating fluid!

Danger of the operating fluid being emitted at the exhaust flange if overfilled.

- Drain the operating fluid to the normal level before restarting the pump.



#### NOTICE

#### Re-starting

The serviceability of the operating fluid without operation is a maximum of 2 years. Before restarting after a shut-down of **2 years or longer**, carry out the following work.

- Replace the operating fluid.
- Replace the radial shaft sealing rings and further elastomer parts.
- Replace bearings at pumps with anti-friction bearings.
- Follow the maintenance instructions and inform Pfeiffer Vacuum.

### 8.3 Disposal

Products or parts thereof (mechanical and electrical components, operating fluids, etc.) may cause environmental burden.

- Safely dispose of the materials according to the locally applicable regulations.

## 9 Malfunctions

Please note the following instructions should the pump malfunction:



#### CAUTION

#### Hot surface!

Danger of burns if hot parts are touched. The surface temperature of the pump may rise above 105 °C in case of malfunction.

- Carry out work on the pump only after it has cooled to a safe temperature.



#### NOTICE

#### Motor overload!

Depending on the malfunction (e.g. blocking during cold start), the motor may not be sufficiently protected by the built-in thermal protection switch from damage through overheating.

- Implement an additional network safety device.

## 9.1 Rectifying malfunctions

Problem	Possible causes	Remedy
Pump will not start up	No mains voltage or voltage does not correspond to the motor data	Check mains voltage and mains fuse protection; check motor switch
	Pump temperature too low	Warm up pump to > 12 °C
	Thermal protection switch has responded	Detect and fix cause of overheating; allow pump to cool off if necessary.
	Pump system dirty	Clean pump; contact Pfeiffer Vacuum Service if necessary.
	Pump system damaged	Clean and overhaul pump; contact Pfeiffer Vacuum Service if necessary.
	Motor defective	Replace motor
Pump switches off after a while after being started	Thermal protection switch of the motor has responded	Detect and fix cause of overheating; allow motor to cool off if necessary.
	Mains fuse protection triggered due to overload (e.g. cold start)	Warm up pump
	Exhaust pressure too high	Check opening of exhaust line and exhaust accessories
Pump does not attain ultimate pressure	Measurement reading is false	Check gauge, check ultimate pressure without installation connected.
	Pump or connected accessories are dirty	Clean pump and check components for contamination.
	Operating fluid dirty	Operate pump for a longer period with gas ballast valve open or change operating fluid
	Leak in system	Repair leak
	Operating fluid filling level too low	Top off operating fluid
	Pump damaged	Contact Pfeiffer Vacuum Service.
Pumping speed of pump too low	Intake line not well-dimensioned	Keep connections as short as possible and see that cross-sections are sufficiently dimensioned
	Exhaust pressure too high	Check opening of exhaust line and exhaust accessories
Loss of operating fluid	Operating fluid separator leaky	Check tightness; replace gasket if necessary
	Radial shaft seal rings leaky	Replace seal ring and check bushing
	Operational loss of operating fluid	Check the oil return unit
Unusual operating noises	Silencer dirty	Clean or replace the silencer.
	Damage to the pump system	Clean and overhaul pump; contact Pfeiffer Vacuum Service if necessary.
	Motor bearing defective	Replace motor; contact Pfeiffer Vacuum Service if necessary



### NOTICE

**Service work should be carried out by a qualified person only!**

Pfeiffer Vacuum is not liable for any damage to the pump resulting from work carried out improperly.

→ Take advantage of our service training programs; additional information at [www.pfeiffer-vacuum.com](http://www.pfeiffer-vacuum.com).

→ Please state all the information on the pump rating plate when ordering spare parts.

## 10 Service

### Pfeiffer Vacuum offers first-class service!

- Maintenance/repairs on site by Pfeiffer Vacuum field service
- Maintenance/repairs in a nearby service center or service point
- Fast replacement with exchange products in mint condition
- Advice on the most cost-efficient and quickest solution

Detailed information and addresses at: [www.pfeiffer-vacuum.com](http://www.pfeiffer-vacuum.com) (Service).

### Maintenance and repairs in Pfeiffer Vacuum ServiceCenter

The following steps are necessary to ensure a fast, smooth servicing process:

- ➔ Download the forms "Service Request" and "Declaration on Contamination".<sup>1)</sup>
- ➔ Fill out the "Service Request" form and send it by fax or e-mail to your Pfeiffer Vacuum service address.
- ➔ Include the confirmation on the service request from Pfeiffer Vacuum with your shipment.
- ➔ Fill in the contamination declaration and enclose it in the shipment (required!).
- ➔ Dismantle all accessories.
- ➔ Drain operating fluid/lubricant.
- ➔ Drain cooling medium, if used.
- ➔ Send the pump or unit in its original packaging if possible.

### Sending of contaminated pumps or devices

No units will be accepted if they are contaminated with micro-biological, explosive or radioactive substances. "Hazardous substances" are substances and compounds in accordance with the hazardous goods directive (current version). If pumps are contaminated or the declaration on contamination is missing, Pfeiffer Vacuum performs decontamination at the shipper's expense.

- ➔ Neutralise the pump by flushing it with nitrogen or dry air.
- ➔ Close all openings airtight.
- ➔ Seal the pump or unit in suitable protective film.
- ➔ Return the pump/unit only in a suitable and sturdy transport container and send it in while following applicable transport conditions.

### Service orders

All service orders are carried out exclusively according to our repair conditions for vacuum units and components.

<sup>1)</sup> Forms under [www.pfeiffer-vacuum.com](http://www.pfeiffer-vacuum.com)

# 11 Spare parts

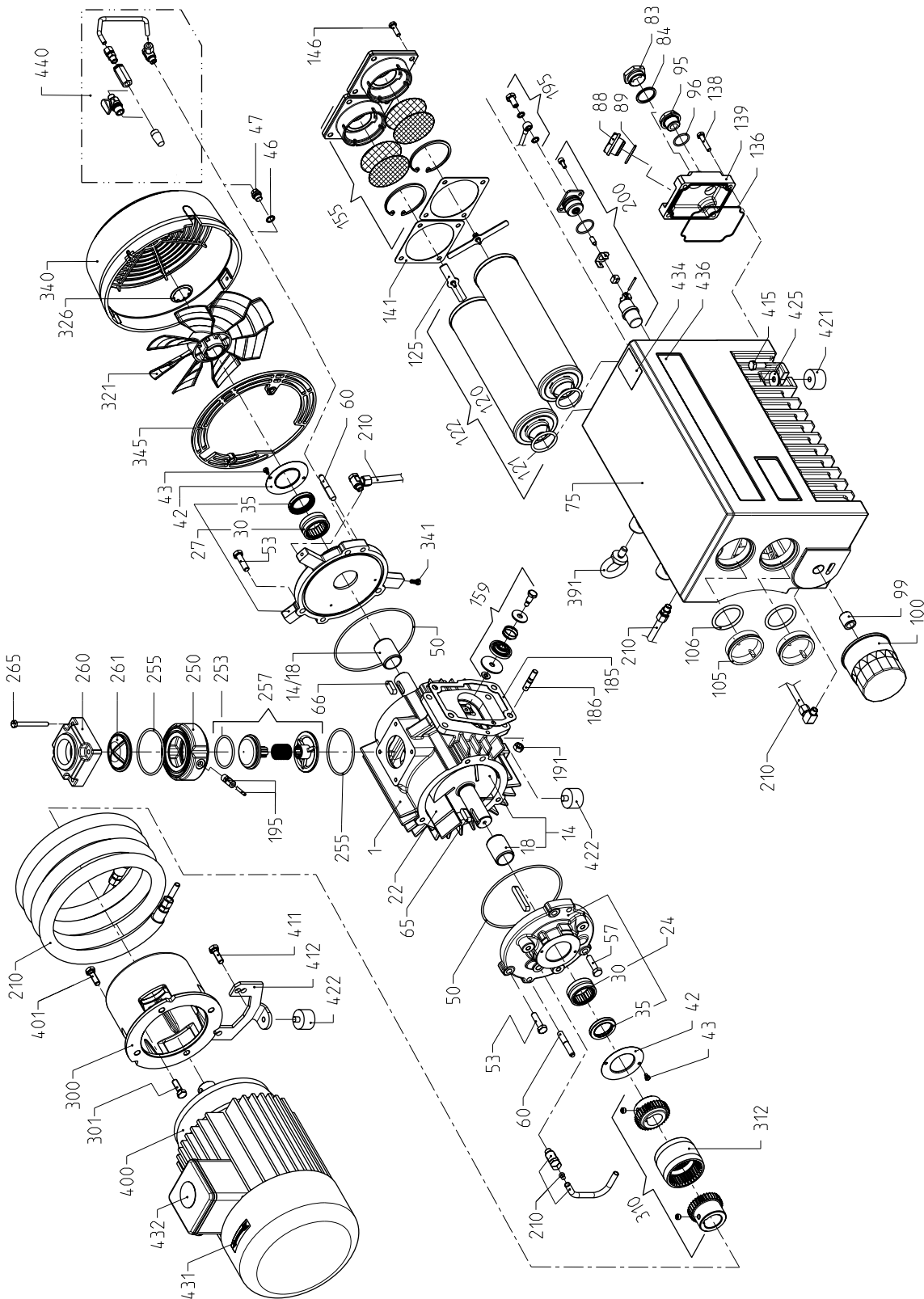

Fig. 13: Exploded view Hena 61/101

1	Cylinder	100	Operating fluid filter	253	O-ring
14	Rotor with sleeve	105	Cover	255	O-ring
18	Sleeve	106	Flat seal	257	Valve set, complete
22	Vane	107	Hexagon head screw/ spring lock washer	260	Intake flange
24	Cylinder cover, side A		Exhaust filter with O-ring	261	Intake sieve
27	Cylinder cover, side B	122	Filter spring	265	Hexagon head screw/spring lock washer
30	Needle bearing		O-ring	300	Motor flange
35	Radial shaft seal	125	Hexagon head screw/ spring lock washer	301	Hexagon head screw/spring lock washer
42	Supporting ring	136	Cover	310	Coupling, complete
43	Hexagon head screw	138	Flat seal	312	Coupling sleeve
46	Seal ring		Hexagon head screw/ spring lock washer	321	Axial fan
47	Locking screw	139	Cover	326	Lock washer
50	O-ring	141	Flat seal	340	Fan cover
53	Hexagon head screw/ Spring lock washer	146	Hexagon head screw/ spring lock washer	345	Protective screen
57	Cylinder pin	155	Separator cover, com- plete	391	Eye bolt
60	Taper pin		Exhaust valve plate, com- plete	400	Motor
65	Shaft key	159	Flat seal	401	Hexagon head screw/spring lock washer
66	Shaft key		Stud	411	Hexagon head screw/spring lock washer
75	Operating fluid separator	185	Spring lock washer	412	Foot
83	Sight glass	186	Hexagon nut	415	Hexagon head screw/spring lock washer
84	Flat seal	187	Operating fluid return line, complete	421	Rubber foot
88	Operating fluid filler screw	191	Float valve, complete	422	Rubber foot
89	O-ring	195	Operating fluid supply, complete	425	Washer
95	Operating fluid drain screw	200	Intake flange, lower housing	440	Gas ballast valve, complete
96	O-ring	210			
99	Nipple	250			

## 11.1 Spare parts packages

Spare parts package	Type	Order no.	existing of position no.
Set of seals	Hena 61/101	PK E60 021 -T	35, 46, 50, 64, 84, 89, 96, 106, 136, 185, 255, 141, 253.
Maintenance kit	Hena 61/101	PK E61 021 -T	89, 96, 100, 141, 122 (120+121).
Overhaul kit	Hena 61	PK E62 022 -T	PK E60 021 -T, 18, 30, 60, 88, 95, 100, 159, 312, 326, 122 (120+121).
	Hena 101	PK E62 023 -T	PK E60 021 -T, 18, 30, 60, 88, 95, 100, 159, 312, 326, 122 (120+121).
Set of vanes	Hena 61	PK E68 022 -T	22
	Hena 101	PK E68 023 -T	22
Operating fluid filter	Hena 61/101	PK 100 129	100
Intake valve	Hena 61/101	PK 100 160 -T	257

## 12 Accessories

Designation	Hena 61	Hena 101
SAS 40, dust separator, DN 40 ISO-KF, polyester filter	PK Z60 510	PK Z60 510
KAS 40, condensate separator	PK Z10 008	PK Z10 008
FAK 040, activated carbon filter	PK Z30 008	PK Z30 008
P3, mineral oil, 1 l	PK 001 106 -T	PK 001 106 -T
P3, mineral oil, 5 l	PK 001 107 -T	PK 001 107 -T
P3, mineral oil, 20 l	PK 001 108 -T	PK 001 108 -T
Flange DN 40 ISO-K - G 1 1/4"	PK 300 525	PK 300 525
Gas ballast valve manuell	PK 100 150	PK 100 150
Pressure gauge for monitoring the operating fluid separator G 3/4"	PK 100 126	PK 100 126

Further detailed accessories are contained in the Pfeiffer Vacuum printed or Online Catalogue.

## 13 Technical data and dimensions

### 13.1 General

- Recommendations of PNEUROP committee PN5
- ISO 21360; 2007: "Vacuum technology - Standard methods for measuring vacuum-pump performance - General description"

**Conversion table: pressure units**

	mbar	bar	Pa	hPa	kPa	Torr mm Hg
mbar	1	$1 \cdot 10^{-3}$	100	1	0.1	0.75
bar	1000	1	$1 \cdot 10^5$	1000	100	750
Pa	0.01	$1 \cdot 10^{-5}$	1	0.01	$1 \cdot 10^{-3}$	$7.5 \cdot 10^{-3}$
hPa	1	$1 \cdot 10^{-3}$	100	1	0.1	0.75
kPa	10	0.01	1000	10	1	7.5
Torr mm Hg	1.33	$1.33 \cdot 10^{-3}$	133.32	1.33	0.133	1

$1 \text{ Pa} = 1 \text{ N/m}^2$

**Conversion table: gas throughput units**

	mbar·l/s	Pa·m <sup>3</sup> /s	sccm	Torr·l/s	atm·cm <sup>3</sup> /s
mbar·l/s	1	0.1	59.2	0.75	0.987
Pa·m <sup>3</sup> /s	10	1	592	7.5	9.87
sccm	$1.69 \cdot 10^{-2}$	$1.69 \cdot 10^{-3}$	1	$1.27 \cdot 10^{-2}$	$1.67 \cdot 10^{-2}$
Torr·l/s	1.33	0.133	78.9	1	1.32
atm·cm <sup>3</sup> /s	1.01	0.101	59.8	0.76	1



## 13.2 Technical data

Parameter	Hena 61	Hena 101
Flange (in)	Female thread G 1 ¼"	Female thread G 1 ¼"
Flange (out)	Female thread G 1 ¼"	Female thread G 1 ¼"
Pumping speed at 50 Hz	63 m <sup>3</sup> /h	100 m <sup>3</sup> /h
Pumping speed at 60 Hz	76 m <sup>3</sup> /h	120 m <sup>3</sup> /h
Ultimate pressure with gas ballast	≤1.5 hPa	≤1.5 hPa
Ultimate pressure without gas ballast	≤0.3 hPa	≤0.3 hPa
Exhaust pressure, min.	Atmospheric pressure	Atmospheric pressure
Exhaust pressure, max.	Atmospheric pressure	Atmospheric pressure
Rotation speed at 50 Hz	1500 min <sup>-1</sup>	1500 min <sup>-1</sup>
Rotation speed at 60 Hz	1800 min <sup>-1</sup>	1800 min <sup>-1</sup>
Leak rate safety valve	≤ 8 · 10 <sup>-3</sup> Pa m <sup>3</sup> /s	≤ 8 · 10 <sup>-3</sup> Pa m <sup>3</sup> /s
Emission sound pressure level without gas ballast at 50 Hz	≤64 dB (A)	≤65 dB (A)
Emission sound pressure level without gas ballast at 60 Hz	≤66 dB (A)	≤68 dB (A)
Ambient temperature	12-40 °C	12-40 °C
Protection category	IP55	IP55
Rated power 50 Hz	2 kW	2,7 kW
Rated power 60 Hz	2.4 kW	3.4 kW
Mains requirement: voltage 50 Hz	190-200/380-400 V	190-200/380-400 V
Mains requirement: voltage 60 Hz	208/220/230/440/460 V	208/220/230/440/460 V
Mains requirement: voltage (range)	± 5 %	±5 %
Switch	No	No
Mains cable	No	No
Shipping and storage temperature	-25-+55 °C	-25-+55 °C
Operating fluid	P3	P3
Operating fluid filling	2 l	2 l
Gas ballast	Yes, without shut- off valve	Yes, without shut-off valve
Weight	65 kg	78 kg
Cooling method, standard	Air	Air

### 13.3 Dimensions

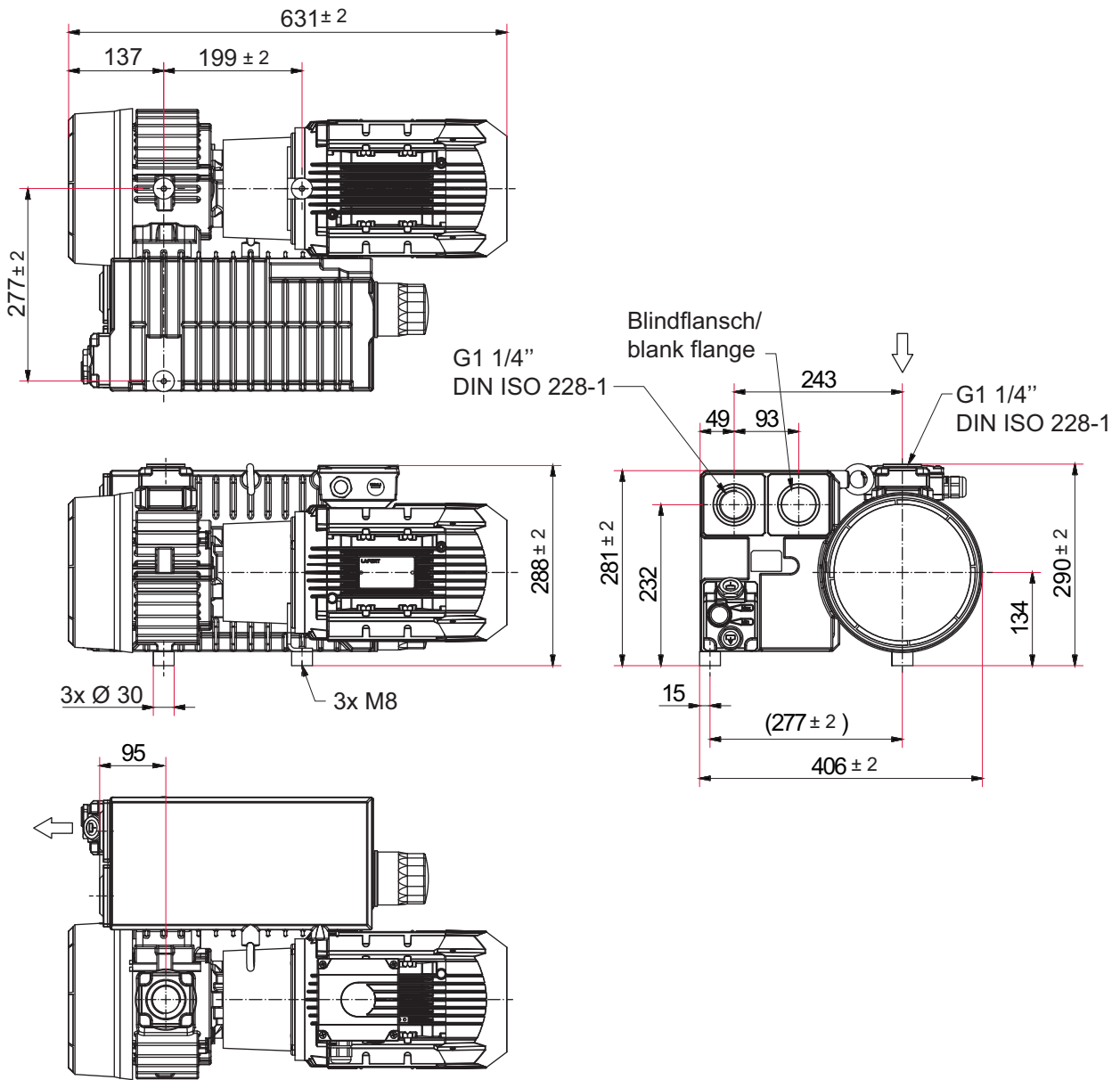

Fig. 14: Hena 61

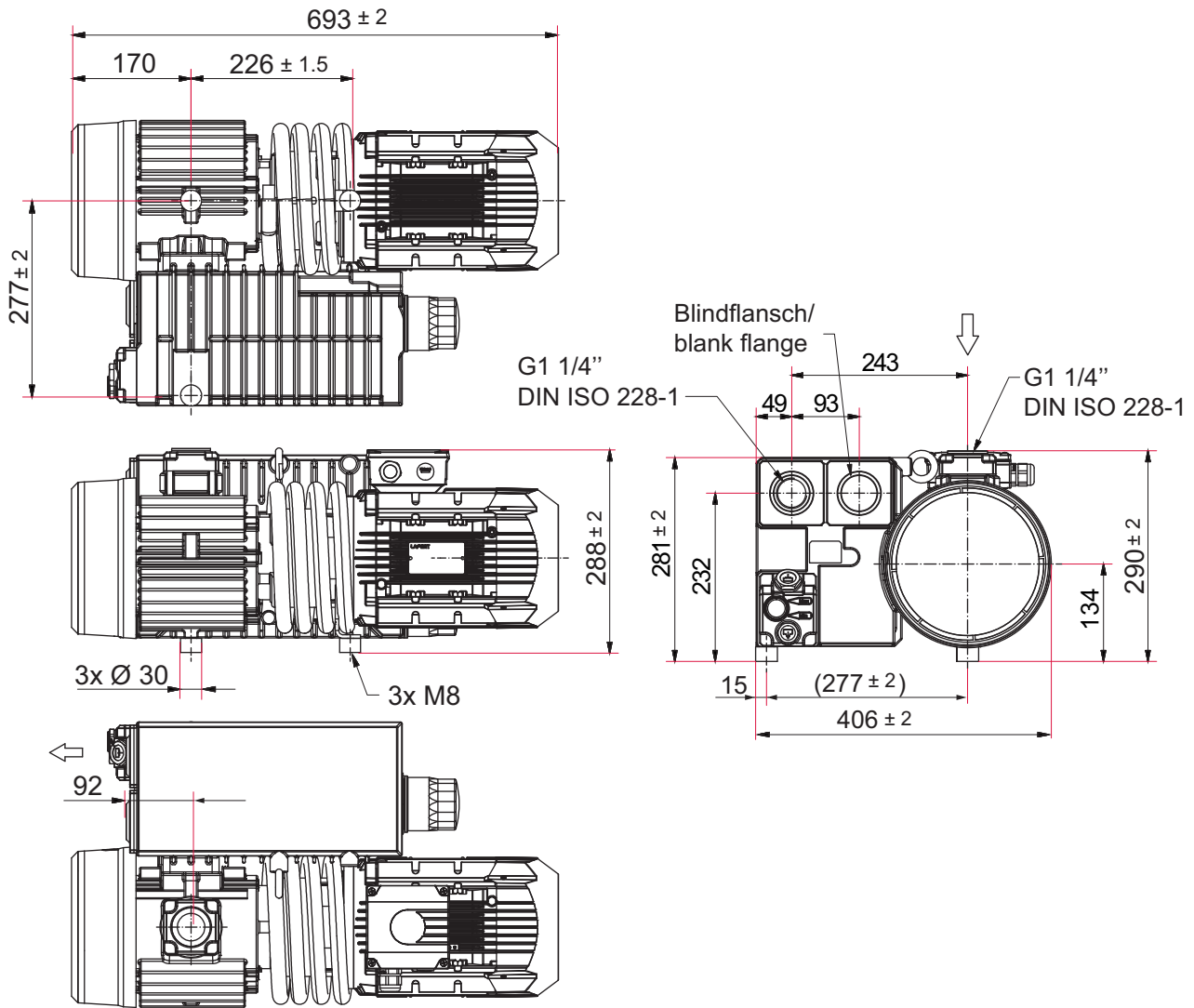

Fig. 15: Hena 101



# Declaration of conformity

We hereby declare that the product cited below satisfies all relevant provisions according to the following **EC directives**:

- **Machinery 2006/42/EC (Annex II, no. 1 A)**
- **Electromagnetic Compatibility 2014/30/EU**
- **Restriction of the use of certain Hazardous Substances 2011/65/EU**

The agent responsible for compiling the technical documentation is Mr. Sebastian Oberbeck, Pfeiffer Vacuum GmbH, Berliner Straße 43, 35614 Asslar.

**HenaLine™**  
**Hena 61/101**

Harmonised standards and national standards and specifications which have been applied:

DIN EN ISO 12100 : 2010	DIN EN ISO 13857 : 2008	DIN EN 61000-6-3 : 2007 + A1: 2011
DIN EN 1012-1 : 2010	DIN EN 61000-6-1 : 2007	DIN EN 61000-6-4 : 2007 + A1: 2011
DIN EN 1012-2 : 2011-12	DIN EN 61000-6-2 : 2006	
DIN EN ISO 2151 : 2: 2008		

Signature:

Pfeiffer Vacuum GmbH  
Berliner Straße 43  
35614 Asslar  
Germany

(Dr. Ulrich von Hülsen)  
Managing Director

Asslar, 2017-12-08

## **VACUUM SOLUTIONS FROM A SINGLE SOURCE**

Pfeiffer Vacuum stands for innovative and custom vacuum solutions worldwide, technological perfection, competent advice and reliable service.

## **COMPLETE RANGE OF PRODUCTS**

From a single component to complex systems:

We are the only supplier of vacuum technology that provides a complete product portfolio.

## **COMPETENCE IN THEORY AND PRACTICE**

Benefit from our know-how and our portfolio of training opportunities!

We support you with your plant layout and provide first-class on-site service worldwide.

Are you looking for a  
perfect vacuum solution?  
Please contact us:

**Pfeiffer Vacuum GmbH**  
Headquarters • Germany  
T +49 6441 802-0  
info@pfeiffer-vacuum.de

[www.pfeiffer-vacuum.com](http://www.pfeiffer-vacuum.com)

**PFEIFFER**  **VACUUM**