



Atlas Copco GVD 40, GVD 80

Technical Specifications

	GVD 40		GVD 80	
	50 Hz	60 Hz	50 Hz	60 Hz
Displacement	42.5 m ³ h ⁻¹ / 25 cfm	50.5 m ³ h ⁻¹ / 29.7 cfm	80 m ³ h ⁻¹ / 47.1 cfm	96 m ³ h ⁻¹ / 56.5 cfm
Speed (Pneurop 6602)	37 m ³ h ⁻¹ / 21.8 cfm	44 m ³ h ⁻¹ / 25.9 cfm	74 m ³ h ⁻¹ / 43.6 cfm	90 m ³ h ⁻¹ / 53 cfm
Ultimate vacuum (total pressure) without gas ballast	1 x 10 ⁻³ mbar / 7.7 x 10 ⁻⁴ Torr		1 x 10 ⁻³ mbar / 7.7 x 10 ⁻⁴ Torr	
Ultimate vacuum (total pressure) with gas ballast	7 x 10 ⁻³ mbar / 5.4 x 10 ⁻³ Torr		7 x 10 ⁻³ mbar / 5.4 x 10 ⁻³ Torr	
Inlet connection suitable for	DN40 ISO-KF		DN40 ISO-KF	
Outlet connection suitable for	DN25 ISO-KF		DN25 ISO-KF	
Max. outlet pressure	0.5 bar / 7 psig gauge		0.5 bar / 7 psig gauge	
Max. inlet pressure for water vapor	7 mbar / 5.3 Torr		5 mbar / 3.8 Torr	
Max. water vapor pumping rate	0.2 kg h ⁻¹ / 0.4 lb h ⁻¹		0.3 kg h ⁻¹ / 0.7 lb h ⁻¹	
Weight (without oil)	82 kg / 179 lb		125 kg / 275 lb	
Motor protection rating	IP55		IP55	
Motor power	1.1 kW / 1.5 hp*	1.5 kW / 2 hp	2.2 kW / 3 hp*	3 kW / 4 hp
Maximum oil capacity	3.5 litre / 3.2 qt		6.3 litre / 6.7 qt	
Minimum oil capacity	1.32 litre / 1.6 qt		4 litre / 4.2 qt	
Noise level	65 dB (A)		70 dB (A)	

* GVD 40 1.5 kW at 50/60 Hz and GVD 80 3.0 kW at 50/60 Hz.
 All motors are 3-phase energy-efficient.
 IEC EN60034.





PROVAC

SALES

PHONE: 831-462-8900

FAX: 831-462-3536

WWW.PROVAC.COM

Atlas Copco GVD 40, GVD 80 Pumping Curves

50Hz

1: Without gas ballast.
2: With gas ballast open.

60Hz

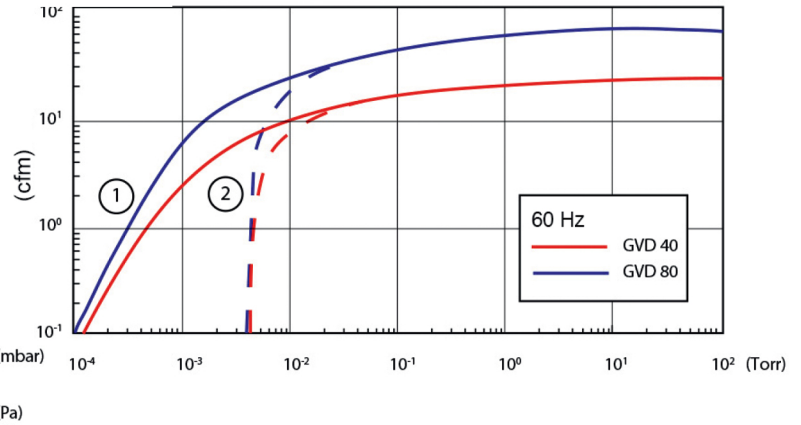
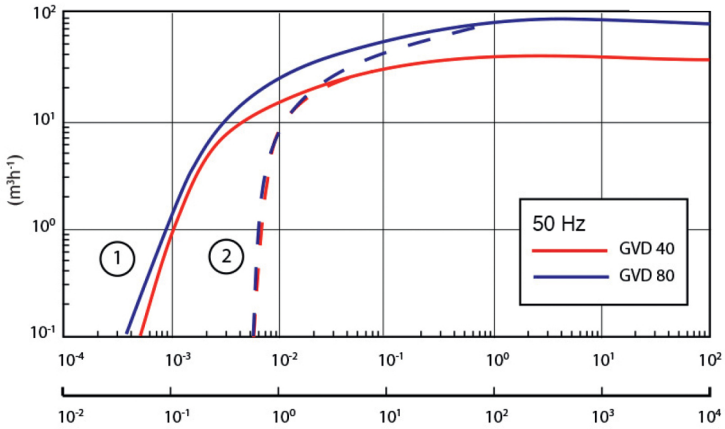

Dimensions

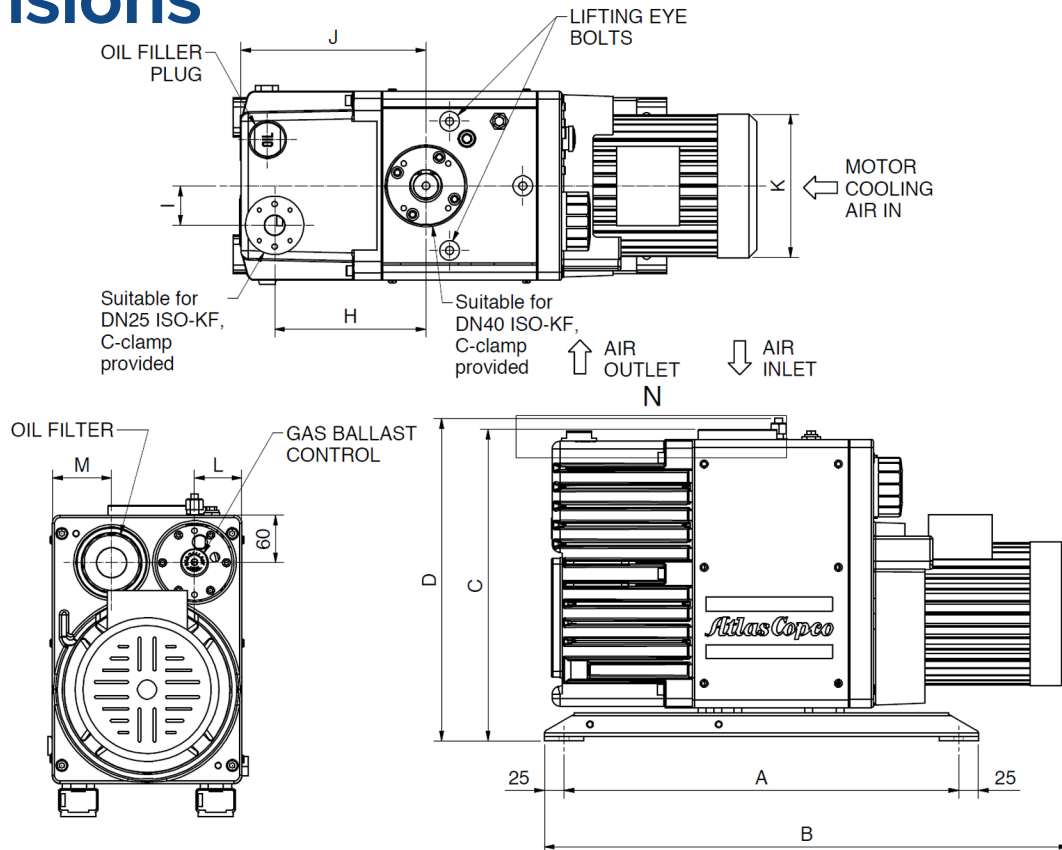

MODEL	A	B	C	D	E	F	G	H	I	J	K	L	M
GVD 40	500	690	395	409	174	240	253	192	50	235	182	60	75
GVD 80	550	796	429	445	196	266	274	221	53	271	198	75	84



PROVAC

SALES

PHONE: 831-462-8900

FAX: 831-462-3536

WWW.PROVAC.COM

Atlas Copco GVD 40, GVD 80

Features & Benefits

- spring loaded distributor valve provides oil & air suckback protection
- central inlet port to allow easy mounting of booster pump
- gas ballast control assists in handling high water vapor loads
- effective lubrication under high gas loads
- industrial roller bearings on drive shaft
- advanced pressurized oil circuit
- full height oil sight glass
- easy change oil filter
- easy to maintain

Applications

- refrigeration/air conditioning system evacuation/drying/backfilling
- vacuum drying & distillation • backing pump for high vacuum applications • metallurgy • thin film coating • insulating oil treatment plant • freeze drying • transformer/cable drying & impregnation
- cryogenic vessel evacuation