

Instruction Manual

EXT Split Flow Compound Turbomolecular Pumps



Description	Item Number	Description	Item Number
24 Volt EXT Compound Turbomolecular Pumps:		80 Volt EXT Compound Turbomolecular Pumps:	
EXT200/200H	B756-01-991	EXT200/200H	B756-01-000
EXT200/200Hi	B756-02-991	EXT200/200Hi	B756-02-000
EXT70/200H	B756-03-991	EXT70/200H	B756-03-000
EXT200/200H	B756-24-991	EXT200/200H ICPMS	B756-30-000
EXT200/200H GCMS (Reversed Body)	B756-41-991	80 Volt EXT system (comprising Compound Turbomolecular Pump and EXDC160)	
EXT200/200H LCMS (Reversed Body)	B756-43-991	EXT200/200H	B756-21-000
24 Volt EXT system (comprising Compound Turbomolecular Pump and EXDC160):		EXT200/200Hi	B756-22-000
EXT200/200H	B756-21-991	EXT70/200H	B756-23-000
EXT200/200Hi	B756-22-991		
EXT70/200H	B756-23-991		
EXT200/200H ICPMS	B756-30-991		
EXT200/200H GCMS	B756-40-991		
EXT200/200H GCMS (Reversed Body)	B756-42-991		
EXT200/200H LCMS (Reversed Body)	B756-44-991		





Declaration of Conformity

We, Edwards,
Manor Royal,
Crawley,
West Sussex, RH10 9LW, UK

declare under our sole responsibility, as manufacturer and person within the EU authorised to assemble the technical file, that the product(s)

SPLIT-FLOW EXT Compound Turbomolecular Pump (24 Volts):

EXT200/200H	B756-01-991	EXT200/200Hi	B756-25-991 † *
EXT200/200Hi	B756-02-991	EXT200/200H	B756-26-991 † *
EXT70/200H	B756-03-991	EXT200/200H ICPMS	B756-30-991 *
EXT200/200Hi	B756-05-991 †	EXT200/200H GCMS	B756-40-991 *
EXT200/200H	B756-21-991 *	EXT200/200H GCMS (Reversed body)	B756-41-991 ‡
EXT200/200Hi	B756-22-991 *	EXT200/200H GCMS (Reversed body)	B756-42-991 ‡ *
EXT70/200H	B756-23-991 *	EXT200/200H LCMS (Reversed body)	B756-43-991 ‡
EXT200/200H	B756-24-991	EXT200/200H LCMS (Reversed body)	B756-44-991 ‡*

SPLIT-FLOW EXT Compound Turbomolecular Pump (80 Volts):

EXT200/200H	B756-01-000	EXT200/200Hi	B756-22-000
EXT200/200Hi	B756-02-000	EXT70/200H	B756-23-000
EXT70/200H	B756-03-000	EXT200/200Hi	B756-25-000 †
EXT200/200H	B756-05-000 †	EXT200/200H	B756-28-000 †
EXT200/200H	B756-07-000	EXT200/200H ICPMS	B756-30-000
EXT200/200H	B756-21-000		

to which this declaration relates is in conformity with the following standard(s) or other normative document(s)

EN ISO 12100-2: 2003 + A1: 2009	Safety of Machinery. Basic Concepts, General Principles for Design. Technical Principals
EN1012-2:1996, A1: 2009	Compressors and Vacuum Pumps. Safety Requirements. Vacuum Pumps
EN61010-1: 2001	Safety Requirements for Electrical Equipment for Measurement, Control and Laboratory Use. General Requirements*
EN 61326-1: 2006	Electrical equipment for measurement, control and laboratory Use. EMC requirements. General requirements.
C22.2 61010-1-04: 2004 [#]	Safety requirements for electrical equipment for measurement, Control and laboratory use - Part 1: General requirements
UL61010-1: 2002 [#]	Safety requirements for electrical equipment for measurement, Control and laboratory use - Part 1: General requirements

- † Cartridge variants are incomplete machines. They are not covered by the Machinery Safety Directive under this Declaration of Conformity, all other Directives apply.
- The pumps comply with EN61010-1: 2001 when installed in accordance with the instruction manual supplied with the pumps.
- * Including EXDC160 Controller.
- ‡ Including extended vent port adaptor.
- # 80V Pumps only comply with the Canadian Standard Authority and Underwriters Laboratory when used with EXC100E, EXC100L controllers and EXDC 80V family of controllers.
24V Pumps only comply with the Canadian Standard Authority and Underwriters Laboratory when used with EXDC 24V family of controllers.

and fulfils all the relevant provisions of

2006/42/EC	Machinery Directive
2006/95/EC	Low Voltage Directive
2004/108/EC	Electromagnetic Compatibility (EMC) Directive

Note: This declaration covers all product serial numbers from the date this Declaration was signed onwards.

B. D. Brewster, Technical Manager,
Burgess Hill Products

02-06-2010

Date and Place

This product has been manufactured under a quality system registered to ISO9001



Declaration of Incorporation

We, Edwards,
Manor Royal,
Crawley,
West Sussex, RH10 9LW, UK

declare under our sole responsibility, as manufacturer and person within the EU authorised to assemble the technical file, that the machine(s)

SPLIT-FLOW EXT Compound Turbomolecular Pump (24 Volts):

EXT200/200Hi	B756-05-991
EXT200/200Hi	B756-25-991
EXT200/200H	B756-26-991

SPLIT-FLOW EXT Compound Turbomolecular Pump(80 Volts):

EXT200/200H	B756-05-000
EXT200/200Hi	B756-25-000
EXT200/200H	B756-28-000

to which this declaration relates is intended to be incorporated into other equipment and not to function independently. The machine(s) must not be put into service until the equipment into which it is incorporated has been brought into conformity with the provisions of the Machinery Directive, 2006/42/EC.

The machine(s) is in conformity with the following standard(s) or other normative document(s)

EN ISO 12100-2: 2003 + A1: 2009	Safety of Machinery. Basic Concepts, General Principles for Design. Technical Principals
EN1012-2:1997, A1: 2010	Compressors and Vacuum Pumps. Safety Requirements. Vacuum Pumps

The relevant essential requirements of the Machinery Directive 2006/42/EC Annex 1 have been applied and fulfilled so far as practicable for this partly completed machinery. The relevant technical documentation has been compiled in accordance with Annex VII Part B. In response to a reasoned request by the national authorities, Edwards Ltd undertakes to provide relevant information on the partly completed machinery (via email).

Note: This declaration covers all product serial numbers from the date this Declaration was signed onwards.

B. D. Brewster, Technical Manager - Burgess Hill Products

22 December 2009

Date and Place

This product has been manufactured under a quality system registered to ISO9001

This page intentionally blank.

Contents

Section	Page
1	Introduction 1
1.1	Scope and definitions 1
2	Technical data 3
2.1	General 3
2.2	Pumping media 3
2.3	Vent gas specification and vent control data 4
2.4	Water-cooling 5
2.5	Materials exposed to gases pumped 9
3	Installation 13
3.1	Unpack and inspect 13
3.2	Typical installation 13
3.3	Connection to the vacuum system 14
3.3.1	Mechanical fixing 15
3.3.2	Inlet-screens (supplied fitted) or integral mesh centering ring (supplied separate from the pump) 16
3.3.3	Inlet connection and orientation 16
3.3.4	Backing connection 17
3.3.5	Interstage connection (Hi pump variants only) 18
3.4	Vent options, vent valve connection and control 18
3.5	Electrical installation 18
3.5.1	EXDC controllers 19
3.5.2	EXC controllers 19
3.6	Cooling 19
3.6.1	Introduction 19
3.6.2	Forced-air cooling 20
3.6.3	Water-cooling 20
4	Operation 21
4.1	Start-up 21
4.2	Shut-down 21
4.3	Safety interlocks and control system 22
4.3.1	EXDC controllers 22
4.3.2	EXC controllers 22
5	Maintenance 23
5.1	Introduction 23
5.2	Bearing maintenance 23
5.3	Rotor life 23
5.4	Cleaning the pump 24
5.5	Fault finding 24
6	Storage and disposal 27
6.1	Storage 27
6.2	Disposal 27
7	Service, spares and accessories 29
7.1	Introduction 29
7.2	Service 29

7.3	Spares	29
7.3.1	ISX inlet-screens	29
7.3.2	Inlet-strainer (interstage pumps only)	30
7.3.3	Inlet-flange seals	30
7.4	Accessories	30
7.4.1	Installation	30
7.4.2	EXDC drive modules	30
7.4.3	EXC controllers	30
7.4.4	Pump-to-controller cables	31
7.4.5	EXT water cooling block assembly	31
7.4.6	TAV vent-valve and vent-port adaptor	31
7.4.7	ACX air-cooler	31
7.4.8	VRX vent-restrictor	32
	Index	33

For return of equipment, complete the HS Forms at the end of this manual.

Illustrations

Figure		Page
1	Dimensions of the EXT 200/200H split flow pump system (units in mm)	9
2	Dimensions of the EXT 200/200H GCMS split flow pump system (units in mm)	10
3	Dimensions of the EXT 200/200H ICPMS split flow pump system (units in mm)	11
4	Dimensions of the EXT 200/200H GCMS/LCMS (reversed body)	12
5	A typical vacuum system using a turbomolecular pump	14
6	Correct installation of inlet screen	16
7	Mounting attitude range of an EXT split flow pump	17
8	Installation of optional accessories	32

Tables

Table		Page
1	General	3
2	Vent gas and vent control data	4
3	Water-cooling	5
4	Technical data	6
5	List of items supplied	15
6	Vent-restrictor orifice diameter (with atmospheric pressure at the inlet of the vent-valve)	18
7	Fault finding	25
8	ISX inlet-screens	29
9	Inlet-strainer (interstage pumps only)	30
10	Inlet-flange seals	30
11	EXDC drive modules	30
12	EXC controllers	30
13	Pump-to-controller cable	31
14	EXT water cooling block assembly	31
15	TAV vent-valve and vent-port adaptor	31
16	ACX air-cooler	31
17	VRX vent-restrictor	32

1 Introduction

1.1 Scope and definitions

This manual provides installation, operation, maintenance and storage instructions for the Edwards EXT70/200H and EXT200/200H Split Flow Compound Molecular Pumps, abbreviated to EXT Split Flow Pump in the remainder of this manual. Covering both the 24 V and 80 V variants. Please read and follow all instructions in this manual.

The EXT Split Flow Pumps are designed for use with an Edwards EXDC or EXC Controller. Read this manual and the instruction manual supplied with your controller before you attempt to install or operate the equipment. The controller manual contains details of electrical installation.

Important safety information in this manual is highlighted as WARNING and CAUTION instructions; please obey these instructions. The use of WARNINGS and CAUTIONS is defined below.



WARNING

Warnings are given where failure to observe the instruction could result in injury or death to people.

CAUTION

Cautions are given where failure to observe the instruction could result in damage to the equipment, associated equipment and process.

In accordance with the recommendations of EN61010, the following warning symbols may appear on the pump or its accessories:



Warning - refer to accompanying documentation.



Warning - risk of electric shock.



Warning - hot surfaces.

The units used throughout this manual conform to the SI international system of units of measurement. Also throughout this manual, wherever flow rates are specified, the abbreviation 'sccm' is used to mean standard $\text{cm}^3\text{min}^{-1}$: this is a flow of $1\text{cm}^3\text{min}^{-1}$ at an ambient temperature of 0°C and a pressure of 1013 mbar (1.013×10^5 Pa).

This page has been intentionally left blank.

2 Technical data

2.1 General

Table 1 - General

Performance	See Table 4
Dimensions	See Figure 1, 2, 3 and 4
Maximum inlet-flange temperature	70°C
Maximum magnetic field	3.5 mT Horizontal field
Installation category	EN61010 part 1, Category 1
Pollution degree	CAN/CSA, UL, EN610101 part 1
Altitude	2000 m
Humidity	10 to 90% non condensing
Electrical supply	
BXXX-XX-991	24 V d.c.
BXXX-XX-000	80 V d.c.
Equipment type	Fixed equipment, for indoor use only

2.2 Pumping media



WARNING

Vent dangerous gases and gas mixtures safely. Do not expose people to these gases.



WARNING

Do not use Split Flow Pumps to pump explosive gas mixtures as the pumps are not suitable for this purpose.



WARNING

If pyrophoric gases are pumped then the customer must supply adequate dilution with an inert gas.



WARNING

It is the customers responsibility to leak check their system to ensure any process gases cannot escape to the atmosphere and cause a hazard.



WARNING

Gases pumped from different inlets may combine to cause dangerous mixtures.



WARNING

If pumping hazardous gases or vapours, the customer must observe the safety recommendations of the supplier of the gas or vapour.

CAUTION

Do not use an EXT Split Flow Pump to pump gases containing more than 20% oxygen. If you do, the lubricant will polymerise and the pump will fail prematurely.

Note: Concentrations of gases may be modified by the compression of the pump.

The pumps are designed to pump the following residual gases normally used in high-vacuum systems:

- Air
- Carbon monoxide
- Neon
- Ethane
- Methane
- Nitrogen
- Krypton
- Argon
- Propane
- Carbon dioxide
- Helium
- Hydrogen
- Butane

You can use the pumps to pump oxygen and water vapour, subject to the following conditions:

- Oxygen - The oxygen concentration must be less than 20% by volume.
- Water vapour - You must ensure that vapour does not condense inside the pump; refer to [Section 3.6.3](#).

If you wish to pump a gas not in the list above, contact your supplier for advice. If you do not contact your supplier, you may invalidate the warranty on the pump. The pumps are not suitable for pumping aggressive or corrosive gases.

2.3 Vent gas specification and vent control data

Although the pump may be vented to atmosphere, high relative humidity of the air may greatly increase the subsequent pump-down time. To reduce pump-down times you should vent the pump with dry, clean gases.

Table 2 - Vent gas and vent control data

Vent gas	Dry air, nitrogen, argon or other inert gases
Maximum dew point at atmospheric pressure	-22 °C
Maximum size of particulate	1 µm
Maximum concentration of oil	0.1 parts per million
Time for rotational speed to reach 50%	> 15 sec
Maximum vent gas pressure	< 0.5bar gauge (7 psig, 0.5x10 ⁵ Pa gauge)*

* If you wish to use vent pressures in excess of this value, please consult Edwards

2.4 Water-cooling

The following cooling-water specification corresponds to a typical high-quality drinking water specification. Check with your water supply authority if you are in doubt about the quality of your supply.

Table 3 - Water-cooling

Quality	Mechanically and optically clean with no deposits or turbidity
pH value	6.0 to 8.0
Maximum calcium carbonate concentration	75 parts per million
Maximum chloride concentration	100 parts per million
Minimum oxygen concentration	4 parts per million
Minimum water-cooling flow rate (at 15 °C)	15 l hr ⁻¹
Water temperature	See Table 4
Maximum water pressure	5 bar (gauge), 73.5 psig, 6x10 ⁵ Pa
Materials exposed to cooling-water	Nickel plated brass

Table 4 - Technical data

Parameter	EXT70/200H	EXT200/200H and Hi	EXT200/200H GCMS*	EXT 200/200H ICPMS	Notes
Mass	9 kg	9 kg (7.5 kg [†])	9 kg	9 kg	mass without controller controller
Side inlet-flange	DN100ISO	DN100ISO	DN100ISO	DN100ISO	
Main inlet-flange	DN63ISO	DN100ISO	DN100ISO	DN100ISO	
Outlet-flange	DN25NW	DN25NW	DN25NW	DN25NW	
Vent-port	1/8 inch BSP	1/8 inch BSP	1/8 inch BSP	1/8 inch BSP	
Interstage-port (optional)	DN25NW	DN25NW	DN25NW	DN25NW	
Main inlet pumping speed					
N ₂ ^{†††}	110 l s ⁻¹	177 l s ⁻¹	155 l s ⁻¹	107 l s ⁻¹	Pb < 5 mbar (500 Pa)
He ^{†††}	145 l s ⁻¹	190 l s ⁻¹	185 l s ⁻¹	113 l s ⁻¹	Pb < 1 mbar (100 Pa)
H ₂ ^{†††}	130 l s ⁻¹	163 l s ⁻¹	175 l s ⁻¹	102 l s ⁻¹	Pb < 0.5 mbar (50 Pa)
Ar ^{†††}	-	-	153 l s ⁻¹	104 l s ⁻¹	Pb < 0.2 mbar (20 Pa)
Side inlet pumping speed					
N ₂ ^{†††}	155 l s ⁻¹	155 l s ⁻¹	155 l s ⁻¹	155 l s ⁻¹	Pb < 5 mbar (500 Pa)
He ^{†††}	131 l s ⁻¹	131 l s ⁻¹	179 l s ⁻¹	187 l s ⁻¹	Pb < 1 mbar (100 Pa)
H ₂ ^{†††}	79 l s ⁻¹	79 l s ⁻¹	131 l s ⁻¹	143 l s ⁻¹	Pb < 0.5 mbar (50 Pa)
Ar ^{†††}	-	-	127 l s ⁻¹	148 l s ⁻¹	
Interstage pumping speed					
N ₂ [†]	-	8.75 l s ⁻¹	N/A	N/A	Pb = 5 mbar (500 Pa)
He [†]	-	10.4 l s ⁻¹	N/A	N/A	Pb = 5 mbar (500 Pa) P ₁ = 5 x 10 ⁻¹ mbar (50 Pa)
Compression ratio from the backing port to the main inlet					
N ₂	>5 x 10 ⁷	>5 x 10 ⁷	>5 x 10 ^{7††}	>5 x 10 ^{7††}	
He	1 x 10 ⁶	1 x 10 ⁶	1 x 10 ⁷	2.5 x 10 ⁷	
H ₂	3.5 x 10 ⁴	3.5 x 10 ⁴	-	5 x 10 ⁵	
Ar	-	-	>5 x 10 ^{7††}	>5 x 10 ^{7††}	
Compression ratio from the side inlet to the main inlet					
N ₂	6 x 10 ³	6 x 10 ³	1 x 10 ⁴	9 x 10 ³	
He	6 x 10 ²	6 x 10 ²	1.5 x 10 ²	2.5 x 10 ²	
H ₂	2 x 10 ¹	2 x 10 ¹	3.3 x 10 ¹	6 x 10 ¹	
Ar	-	-	1.7 x 10 ⁴	7 x 10 ³	

Table 4 - Technical data (continued)

Parameter	EXT70/200H	EXT200/200H and Hi	EXT200/200H GCMS*	EXT 200/200H ICPMS	Notes
Maximum backing pressure***					
N ₂	12.6 mbar (1260 Pa)	12.6 mbar (1260 Pa)	7.3 mbar (730 Pa)	-	
He	7.7 mbar (770 Pa)	7.7 mbar (770 Pa)	-	-	
H ₂	2 mbar (200 Pa)	2 mbar (200 Pa)	-	-	
Ar	-	-	-	8 mbar (800 Pa)	
Minimum backing pump displacement	0.6 m ³ h ⁻¹	0.6 m ³ h ⁻¹	0.6 m ³ h ⁻¹	0.6 m ³ h ⁻¹	
Maximum continuous inlet pressure - water-cooling at 35 °C†††					No water cooling on GCMS and ICPMS.
Main inlet	2.5 x 10 ⁻³ mbar (2.5 x 10 ⁻¹ Pa)	2.5 x 10 ⁻³ mbar (2.5 x 10 ⁻¹ Pa)			
Side inlet	5 x 10 ⁻³ mbar (5 x 10 ⁻¹ Pa)	5 x 10 ⁻³ mbar (5 x 10 ⁻¹ Pa)			
Maximum continuous inlet pressure - air-cooling at 35 °C ambient †††					Air-cooling is beneficial to the EXDC controller. Nitrogen unless otherwise stated.
Main inlet	3 x 10 ⁻³ mbar (3 x 10 ⁻¹ Pa)	3 x 10 ⁻³ mbar (3 x 10 ⁻¹ Pa)	5 x 10 ⁻³ mbar (He: 7.5 x 10 ⁻³ mbar)	1 x 10 ⁻² mbar (Ar: 5 x 10 ⁻³ mbar)	
Side inlet	9 x 10 ⁻³ mbar (9 x 10 ⁻¹ Pa)	9 x 10 ⁻³ mbar (9 x 10 ⁻¹ Pa)	1.5 x 10 ⁻² mbar (He: 5 x 10 ⁻³ mbar)	1 x 10 ⁻² mbar (Ar: 5 x 10 ⁻³ mbar)	
Operating attitude	Vertical and upright through to horizontal ±2 °	Vertical and upright through to horizontal ±2 °	Vertical	Vertical	
Nominal rotational speed	60000 r min ⁻¹	60000 r min ⁻¹	60000 r min ⁻¹	60000 r min ⁻¹	
Standby rotational speed	42000 r min ⁻¹	42000 r min ⁻¹	42000 r min ⁻¹	42000 r min ⁻¹	EXC controller only

Table 4 - Technical data (continued)

Parameter	EXT70/200H	EXT200/200H and Hi	EXT200/200H GCMS*	EXT 200/200H ICPMS	Notes
Starting time to 90% speed					
EXDC160	110 se	110 sec	120 sec	150 sec	
EXC100E	190 sec	190 sec			
EXC100L				245 sec	
EXC120	130 sec	130 sec			
EXC300	100 sec	100 sec		120 sec	
EXDC80			270 sec	330 sec	
Cooling method	Forced-air/ water	Forced-air/ water			
Ambient air temperature (forced-air cooling)	0 - 35 °C	0 - 35 °C	0 - 35 °C	0 - 35 °C	
Water temperature (water-cooling)	10 - 20 °C	10 - 20 °C	-	-	
Noise level (at 1 metre)	< 50 dB(A)	< 50 dB(A)	< 50 dB(A)	< 50 dB(A)	
Recommended controller	EXDC160	EXDC160	EXDC160	EXDC160	
EXDC160 maximum VA input	250 VA	250 VA	250 VA	250 VA	
Quiescent power	25 W	25 W	40 W	40 W	
Recommended backing pump ^{†††}	RV3	RV3	RV3	RV3	

* The data shown for EXT200/200H GCMS applies to pumps: B75640991, B75641991, B75642991, B75643991 and B75644991. This is because these pumps have the same internal components and the data is taken without inlet screens fitted.

† Mass applies to products listed under the Declaration of Incorporation.

‡ P_b = backing pressure,

P_i inlet pressure,

** Pumping speeds are without inlet-screen or inlet-strainer (EXT200/200Hi, GCMS and ICPMS). Inlet-screens and inlet-strainers reduce speed by approximately 10%.

†† This is a measured value. Theoretical value $>10^9$ and $>10^{11}$ respectively for GCMS and ICPMS.

‡‡ Theoretical values 2×10^9 and 7×10^{11} respectively.

‡‡‡ Inlet pressure has risen to 10^{-3} mbar.

†††† Above this pressure, rotational speed drops below nominal.

††††† A larger backing pump may be required for maximum throughput.

2.5 Materials exposed to gases pumped

The following materials and component types are exposed to the gases pumped: aluminium alloys, stainless steels, fluoroelastomer and nitrile O-rings, hydrocarbon lubricant, felt, rare earth magnets, silicon nitride, phenolic resin and carbon-fibre reinforced epoxy resin.

Figure 1 - Dimensions of the EXT 200/200H split flow pump system (units in mm)

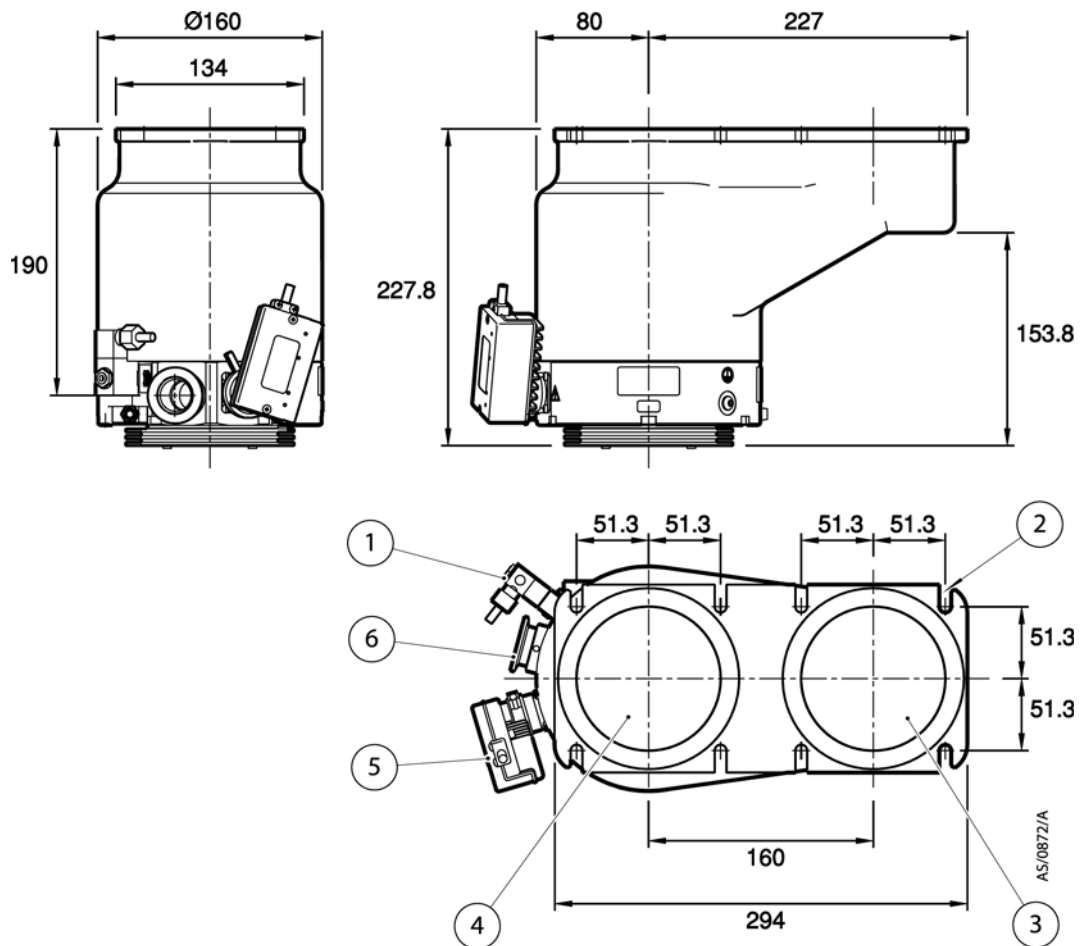

- | | |
|------------------------|--------------------|
| 1. TAV5 vent valve | 4. Main inlet |
| 2. 8 slots 8.4 mm wide | 5. EXDC controller |
| 3. Side inlet | 6. Backing port |

Figure 2 - Dimensions of the EXT 200/200H GCMS split flow pump system (units in mm)

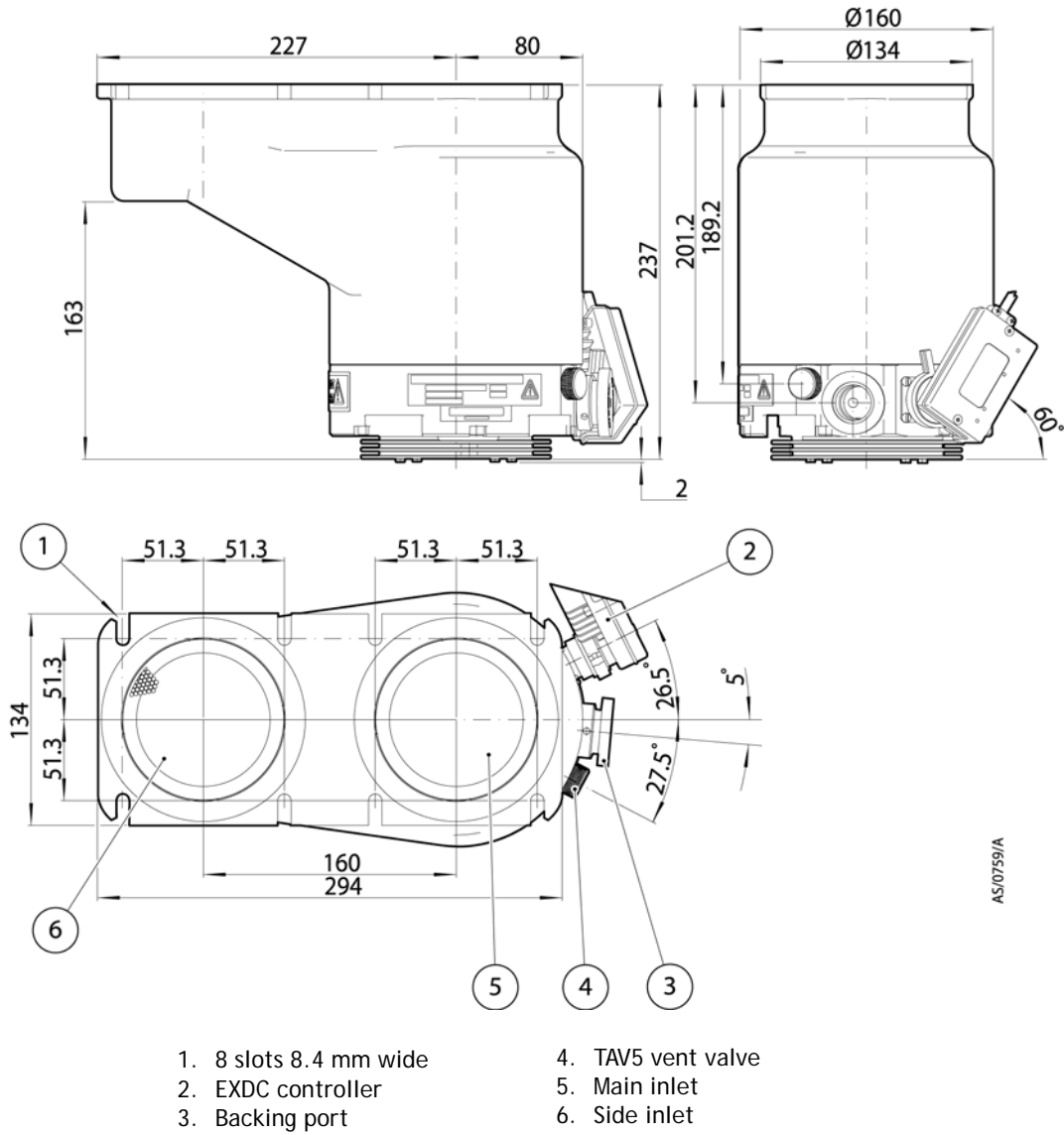
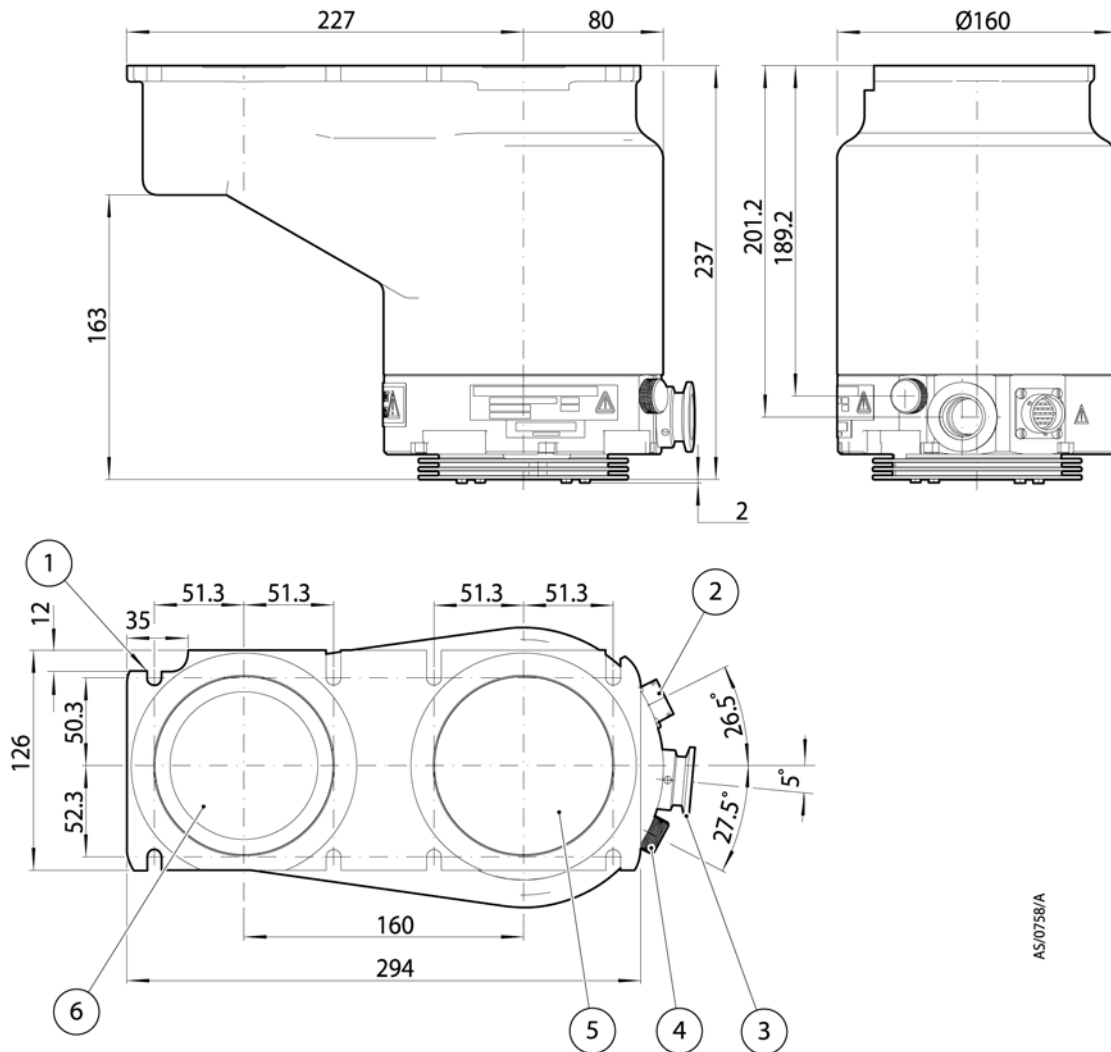

Figure 3 - Dimensions of the EXT 200/200H ICPMS split flow pump system (units in mm)



AS/0758/A

- | | |
|--------------------------|---------------|
| 1. 8 slots 8.4 mm wide | 4. Vent port |
| 2. Controller connection | 5. Main inlet |
| 3. Backing port | 6. Side inlet |

Figure 4 - Dimensions of the EXT 200/200H GCMS/LCMS (reversed body)

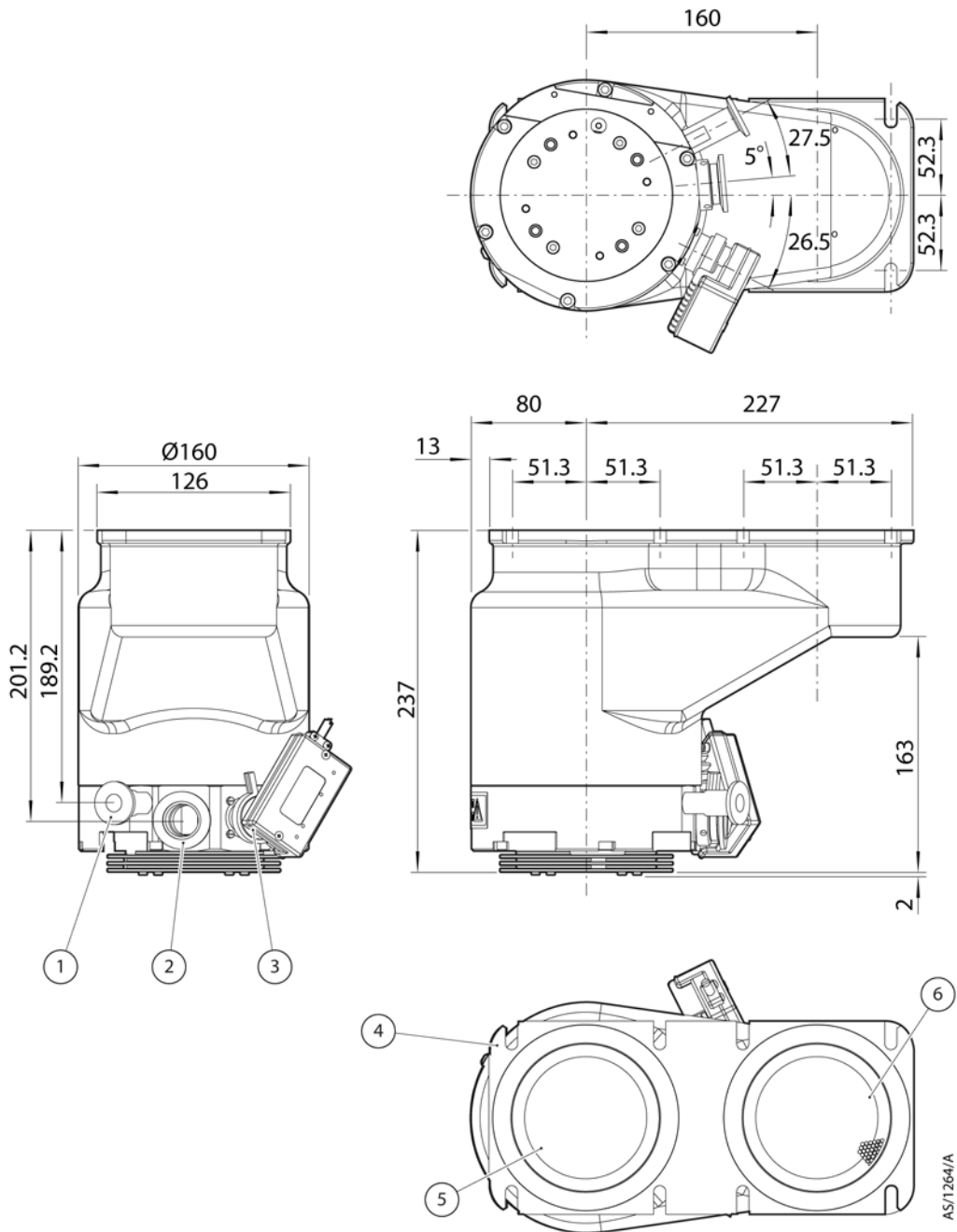

- 1. Extended vent-port adaptor
- 2. Backing port
- 3. EXDC controller
- 4. 8 slots 8.4 mm wide
- 5. Main inlet
- 6. Side inlet

3 Installation

3.1 Unpack and inspect



WARNING

The pump weighs approximately 9 kg (20 lbs). Appropriate care should be taken when lifting and moving the pump to avoid injury.

Take care when you unpack the pump to avoid excessive shocks which could damage the bearings and reduce the life of the pump. The pump is supplied with the inlet and outlet sealed to prevent entry of dust and vapour. Do not remove these seals until you are ready to install the pump on your vacuum system.

Open the top of the packaging by disengaging the cardboard tabs and then opening the lid. Remove the top piece of locating foam and any ancillaries included within the box. You should now be able to remove the pump from the packaging by lifting the pump vertically from the packaging. If the pump is damaged, notify your supplier and the carrier in writing within three days; state the Item Number of the pump together with your order number and your supplier's invoice number. Retain all packing materials for inspection. Do not use the pump if it is damaged.

Check that your package contains the items listed in [Table 5](#). If any of these items is missing, notify your supplier in writing within three days.

If the pump is not to be used immediately, store the pump in suitable conditions as described in [Section 6.1](#).

It is advised to retain all packing materials for use should you return the pump for service.

3.2 Typical installation

CAUTION

Local legislation concerning the impact of the pump on the environment must be followed when installing the pump.

Figure 5 - A typical vacuum system using a turbomolecular pump

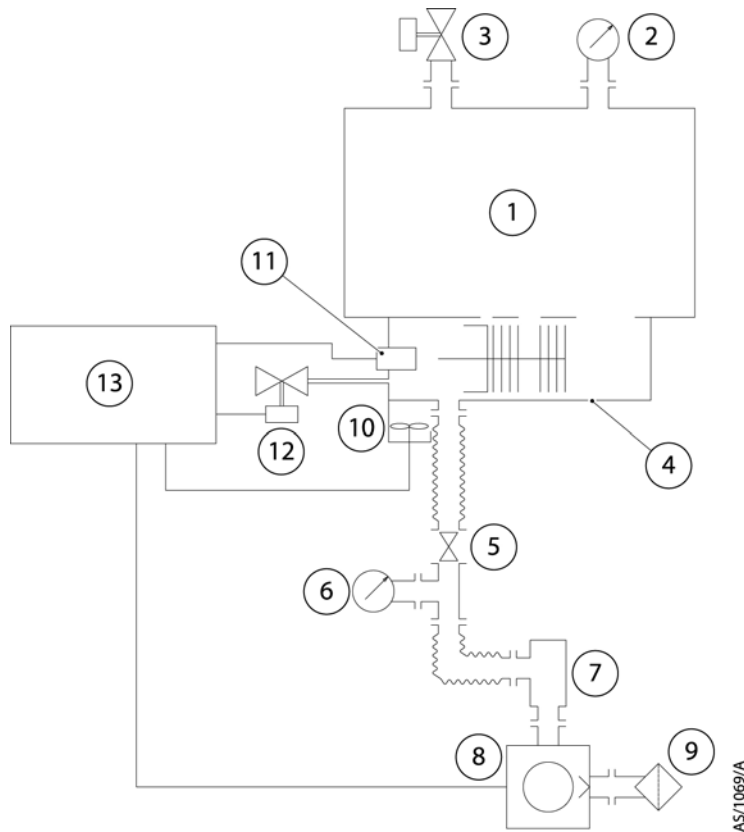

- | | |
|--|------------------------|
| 1. Vacuum system | 7. Foreline trap |
| 2. High vacuum gauge | 8. Rotary backing pump |
| 3. Alternative position for vent valve | 9. Mist filter |
| 4. TMP | 10. Cooling fan |
| 5. Backing valve | 11. EXDC controller |
| 6. Vacuum gauge | 12. Vent valve |
| | 13. Control system |

The accessories available for these EXT Split Flow Pumps are detailed in [Section 7.4](#).

3.3 Connection to the vacuum system



WARNING

Once the pump is removed from the bottom packaging, there is a danger of toppling.



WARNING

Install the pump in the vacuum system before you connect the controller to the power supply. This will ensure that the pump cannot operate and injure people during installation.



WARNING

The impeller blades on a Split Flow Pump are very sharp. Care should be taken when handling the pump not to dislodge or damage the protective inlet screens.

If integral mesh centering rings are supplied with the pump it is the customers responsibility to ensure that these are fitted to the pump inlets and to take appropriate care when handling the pump to avoid the impeller blades. To minimise the risk of injury the plastic transport cover should be retained over the pump inlets until the pump is ready to be installed.



WARNING

Under no circumstances must a part of the human body be exposed to a vacuum.



WARNING

Care must be taken to avoid foreign objects entering the pump during the installation process.

Carefully remove the pump from packaging media and connect to vacuum system.

Table 5 - List of items supplied

Qty	Description
1	EXT Split Flow Pump
2	Inlet-screen (fitted)
2	DN100ISO-K Integral mesh centering ring*
2	Inlet seal (trapped o-rings)
1	Inlet-strainer (Hi variants only, fitted in the interstage-port)
1	EXDC160 Controller (fitted)*
1	NW10-1/8 inch BSP male extended vent port adaptor*
1	NW10 Centering ring*
1	NW10 Clamping ring*
1	NW25 Centering ring*
1	NW25 Clamping ring*

* Only supplied with system variants.

3.3.1 Mechanical fixing



WARNING

Ensure all Split Flow Pumps are securely fixed to the vacuum system via their inlet flange using all available mounting points. If a pump were to seize when not securely mounted, the stored energy of the rotor could cause rapid movement of the pump, which may cause damage to equipment and/or injury to personnel.

For variants listed under the Declaration of Incorporation refer to your own guide lines for mechanical fixing.

3.3.2 Inlet-screens (supplied fitted) or integral mesh centering ring (supplied separate from the pump)



WARNING

Removal of inlet-screens will expose the risk of injury from sharp edges.



WARNING

In the unlikely event of a pump fracture, it is possible that the inlet screen may not trap all debris within the pump. Ensure that the system can contain any debris that may escape from the pump.

Do not remove the inlet-screens unless you can be sure that there is no danger that debris can fall into the pump. If the screens are removed, the pumping speed through each inlet will increase by approximately 10%.

To remove an inlet-screen carefully extract it from the inlet-flange using a bent wire hook. To replace a screen which has been removed, install it as shown in Figure 6, with the Edwards logo uppermost. Ensure that the dimples on the rim of the screen engage in the groove in the pump flange. If necessary, gently bend the tabs of the screen outwards to ensure a tight fit.

Figure 6 - Correct installation of inlet screen

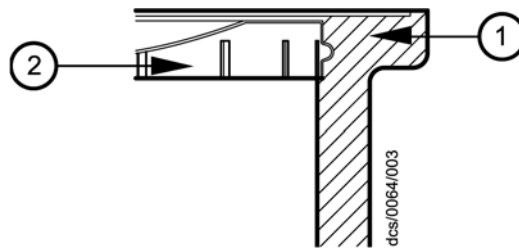

1. Inlet-flange 2. Inlet-screen

3.3.3 Inlet connection and orientation

If integral mesh centering rings are supplied with the pump appropriate care must be taken when handling the pump to avoid the exposed impeller blades. The impeller represents a serious rotational hazard if the pump is operational and a manual handling hazard if the pump impeller is stationary.

Integral mesh centering rings have not been designed to enable the inlet screen to be removed. If the inlet screen is removed it will probably become damaged and non re-usable. If the screen is not required a plain centering ring (B271-58-171 for DN100ISO-K inlet) can be used instead.

CAUTION

Do not invert the pump.

The pump can be mounted in any attitude range shown in Figure 7, from vertical and upright through to horizontal ($\pm 2^\circ$), although it is most commonly mounted vertically. If you mount the pump horizontally, the backing port should point vertically downwards ($\pm 20^\circ$) to reduce the risk of contamination from the backing pump oil.

Make sure that the pump's main inlet and side inlet and all components fitted to the pump-inlets are clean and dust-free. If the pump-inlets are not kept clean, the pump-down time may be increased.

The inlet-connections of the EXT Split Flow Pump are ISO flanges.

Use the Edwards trapped o-ring supplied with the pump and use a minimum of four fixing bolts to connect the inlet-flange of the pump to the vacuum system. M8 bolts should be tightened to a torque of 5-6 Nm.

Figure 7 - Mounting attitude range of an EXT split flow pump

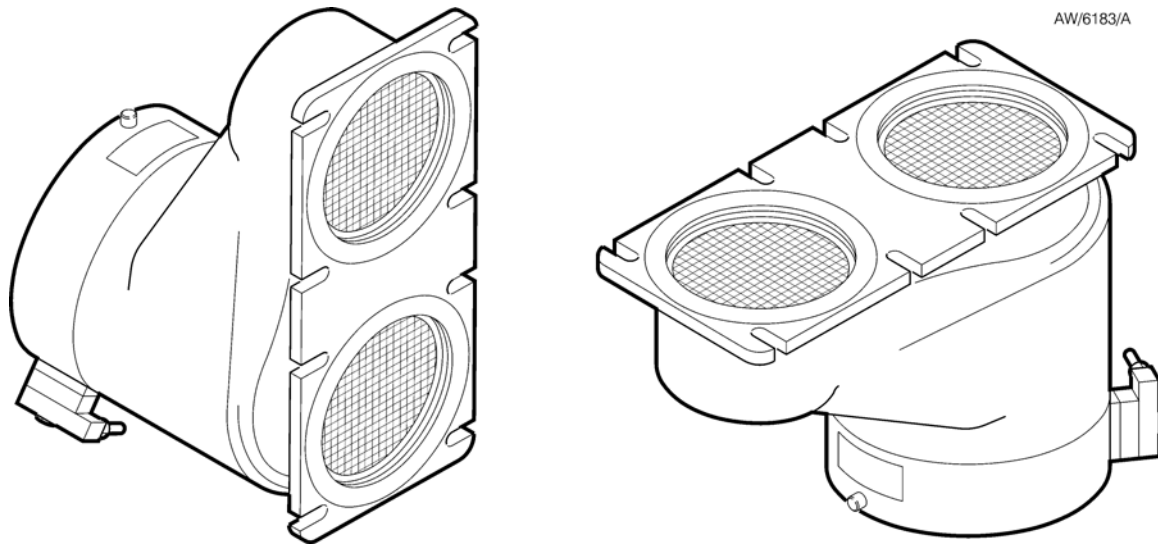

3.3.4 Backing connection



WARNING

The customer must ensure safe ducting of the backing line if oil mist or hazardous substances are present.



WARNING

Split Flow Pumps must not be operated, or vented from a positive pressure gas supply, with a restricted/blocked backing line.
Use suitable vacuum tubing and connectors to connect the NW25 flange of the backing-port to your backing-pump. If necessary, use flexible pipe or bellows to reduce the transmission of vibration from the backing-pump to the Split Flow Pump.

Use suitable vacuum tubing and connectors to connect the NW flange of the backing-port to your backing-pump. If necessary, use flexible pipe or bellows to reduce the transmission of vibration from the backing-pump to the EXT Split Flow Pump.

We recommend that you use an Edwards RV Backing-Pump. The minimum size of the backing-pump required is given in Table 4. You may have to use a larger backing-pump if you run the pump at a high inlet pressure. The EXT70/200H and EXT200/200H Split Flow Pumps are also suitable for use with diaphragm backing-pumps although the effect of higher backing pressure on the pump's performance and cooling requirements should be noted (see Table 1 and Section 3.6).

CAUTION

Do not use the EXT Split Flow Pump with a backing pressure below 5×10^{-4} mbar (5×10^{-2} Pa). Lower backing pressures will increase the evaporation rate of the lubricating oil and so will reduce the life of the bearings.

3.3.5 Interstage connection (Hi pump variants only)

Use suitable vacuum tube and connectors to connect the interstage-port to your vacuum system or to the outlet flange of another turbo molecular pump. Leave the inlet-strainer in the interstage- port, unless you are sure that debris cannot be drawn into the interstage-port.

3.4 Vent options, vent valve connection and control

To maintain the cleanliness of your vacuum system, we recommend that, whenever you switch the pump off, you vent the pump (or vacuum system) when the speed of the EXT Split Flow Pump is between full rotational speed and 50% of full rotational speed. At and above 50% of full rotational speed, the rotor spins fast enough to suppress any backstreaming of hydrocarbon oil from your backing pump. Venting may be accomplished by one of the following methods.

- Use a TAV5 or TAV6 solenoid vent-valve accessory (see Section 7) in place of the manual vent-valve.
- Use a TAV5 or TAV6 solenoid vent-valve connected to a convenient flange on your vacuum system.
- Use an alternative valve, with an appropriate restriction, connected to your vacuum system. For further details contact Edwards.

However, if you manually vent the pump when it is at full rotational speed and the rate of pressure rise is too high, the pump life may be reduced. When using the manual vent valve supplied, we recommend that you either limit the vent or only open the vent-valve after the EXT Split Flow Pump speed has fallen to 50% of full rotational speed.

Do not vent from the backing line, this may lead to contamination. If you vent into your vacuum system, select a point upstream of the pump, to prevent oil backstreaming from the backing line.

If you use the TAV5 or TAV6 vent-valve you can control it using an EXC Controller, or by other methods. Table 6 gives an indication of the appropriate orifice size to be fitted to the vent valve for given vacuum system volumes in order that the vent rate is kept within the limits given in Section 2.3.

Table 6 - Vent-restrictor orifice diameter (with atmospheric pressure at the inlet of the vent-valve)

Vacuum system volume (l)	Orifice diameter (mm)
< 20	< 1.0
< 10	< 0.7
< 5	< 0.5
< 2	< 0.35

3.5 Electrical installation



WARNING

The customer must ensure that any electrical circuits are protected from dripping water caused by condensation on cold surfaces.



WARNING

It is the responsibility of the customer to ensure that the power supply used is correctly rated/ protected.

**WARNING**

This product requires a separate power supply (not included). The power supply should be adequately protected against a hazardous live condition (e.g. in case of a short circuit).

**WARNING**

The customer must ensure appropriate routing of cables and pipework to avoid slip/trip hazards.

**WARNING**

Do not remove the EXDC Controller/EXC Controller cable from the pump until the pump is completely at rest. To do so could expose personnel to hazardous voltage and potentially damage the EXDC/EXC Controller.

The EXT Split Flow Pump should be electrically bonded to earth using the connection provided. Refer to the instruction manual supplied with the controller to complete the electrical installation.

3.5.1 EXDC controllers

**WARNING**

The customer must provide an emergency stop circuit to turn off power to the EXDC controller.

An EXDC Controller requires connection to a suitably rated power supply. The EXDC Controller is designed to allow a pumping system to operate in a fully automatic system.

3.5.2 EXC controllers

The EXC Controller provides the electrical supply to the Split Flow Pump through the pump-to-controller cable. Connect and lock the bayonet connectors at the ends of the cable to the mating connectors on the pump and the EXC Controller (if applicable). If the cable is disconnected at the pump, the EXC Controller output is switched off, making the cable safe. However, if the cable is disconnected from the EXC Controller it should be noted that the other end of the cable is still connected to the pump. Refer to the appropriate warning in [Section 3.5](#) regarding exposure to hazardous voltages whilst the pump is still rotating.

The EXC Controller is designed to allow a pumping system to be configured in a variety of ways, from a basic manually-operated system to a fully automatic system with remote control.

3.6 Cooling

3.6.1 Introduction

CAUTION

You must cool the pump by forced-air or water cooling to prevent damage to the bearing.

You must use water-cooling in addition to forced air cooling in any of the following operating conditions:

Backing pressure > 10 mbar.

Backing pressure > 8 mbar (800 Pa) and interstage flow > 30 sccm (0.5 mbar l s⁻¹, 50 Pa l s⁻¹).

Backing pressure > 5 mbar (500 Pa) and interstage flow > 80 sccm (1.3 mbar l s⁻¹, 130 Pa l s⁻¹).

Ambient temperature > 35 °C.

In all other operating conditions, you can use forced-air cooling only. If you use forced-air to cool the pump, you must ensure that there is an adequate supply of cooling-air to the pump.

During operation, if the temperature of any surface of the pump is higher than 45 °C, the pump is too hot and you must increase the cooling.

3.6.2 Forced-air cooling

An air-cooler accessory is available for the EXT Split Flow Pumps (refer to [Section 7](#)). Fit the air-cooler as described in the instruction manual supplied with it. If you wish to use an alternative fan for air-cooling, ensure that the flow rate is above 70 m³h⁻¹ (40 cfm).

3.6.3 Water-cooling

A water-cooling block accessory is available for the EXT Split Flow Pumps (refer to [Section 7](#)). Fit the water cooling block as described in the instruction manual supplied with it. The cooling-water supply must comply with the specification given in [Section 2.4](#). Pipes in the water-cooling circuit may become blocked if the cooling-water contains too much calcium carbonate or if it contains particulates which are too large. Corrosion of the water-cooling circuit may occur if there is too little calcium carbonate and oxygen in the water. Good quality drinking water is usually suitable for water-cooling. If in doubt, you must check the quality of your cooling-water supply and, if necessary, provide treatment and filtration.

Connect the cooling-water supply to the water-cooler on the pump as described below. Either of the two ruffled connectors on the water-cooler can be used for the water supply or return connections.

1. Push reinforced hose (approximately 6 mm internal diameter) over the ends of the ruffled hose connectors on the water-cooler on the pump.
2. Attach the hose with strong hose clips and make sure that they are tightened securely.

You must turn off the cooling-water supply when you switch off the pump to prevent condensation of vapours inside the pump. The EXC Controller (EXC120 and EXC300) can operate a solenoid-valve for this purpose.

If you want to remove the pump for maintenance, and you do not want to break the cooling-water circuit, unscrew the M4 cap-head fixing-screws and remove the water-cooler from the pump. Make sure that there is a layer of thermal contact grease on the water-cooler before you refit it to the pump.

4 Operation



WARNING

Do not operate the EXT Split Flow Pump unless it is connected to your vacuum system. If you do, the pump rotor can cause injury. The pump rotor rotates at very high speeds and the rotating blades might not be visible.



WARNING

Do not move the pump whilst it is running. The gyroscopic forces generated by this movement can cause excessive use of the back-up bearing and may result in catastrophic failure of the pump.



WARNING

When power is restored following a power cut, the pump will re-start automatically. The pump must remain connected to the vacuum system to prevent risk of injury.



WARNING

After power to the pump has been switched off, either through emergency or as a requirement, the rotor will continue to spin at very high speeds. Until the rotor has stopped it possesses considerable mechanical energy.

4.1 Start-up

Use the procedure below to start up a basic, manually-controlled pumping system with a manual vent-valve and an EXDC version controller. Refer to the EXDC Instruction Manual.

1. Ensure the manual vent-valve is closed (turn clockwise to close it).
2. Turn on the cooling-water supply (if water-cooling is used) and/or switch on the power to the air cooler.
3. Start the backing-pump.
4. When the vacuum system pressure is approximately 10 mbar or less, switch on the power supply to start the EXT Split Flow Pump.
5. The pump will then accelerate to full operating speed. Once nominal operating speed is reached, the normal speed LED on the EXDC Controller will illuminate.

Note: Refer to the controller manual if using the EXC Controller.

4.2 Shut-down



WARNING

Do not remove the EXDC Controller/EXC Controller cable from the pump until the pump is completely at rest. To do so could expose personnel to hazardous voltage and potentially damage the EXDC/EXC Controller.

Note: In an emergency only, open the vent-valve quickly to decelerate the pump rotor in the shortest possible time.

Use the procedure below to shut down a basic, manually-controlled pumping system with a manual vent-valve and an EXDC Controller. Refer to the EXC Controller Instruction Manual when using an EXC Controller.

1. Close the valve in the backing-line connecting the EXT Split Flow pump to the backing-pump.
2. Switch off the backing-pump.
3. Switch off the power supply to the EXT Split Flow Pump.
4. When the EXT Split Flow Pump rotational speed has fallen to 50% of full rotational speed, turn the manual vent-valve anti-clockwise to open it. Ensure that the rate of pressure rise does not exceed the allowed rate of pressure rise, otherwise you can damage the pump: refer to [Section 3.4](#).
5. If water-cooling is in use, turn off the cooling-water supply and/or turn off the power to the air cooler.

4.3 Safety interlocks and control system

The pump protection and safety interlock features are listed below. Refer to the instruction manual supplied with the controller for a full description of these features.

4.3.1 EXDC controllers

- The EXDC Controller monitors the temperature of the EXT Split Flow Pump and the electrical power consumption of the pump. If the EXDC Controller detects excessive power consumption or temperature, the rotational speed of the pump motor is reduced until the power and temperature return to normal.

4.3.2 EXC controllers

- The EXC Controller monitors the temperature of the EXT Split Flow Pump and the electrical power consumption of the pump. If the EXC Controller detects excessive power consumption or temperature, the rotational speed of the pump motor is reduced until the power and temperature return to normal.
- If the rotational speed is reduced to 50% of nominal speed, then power is removed (or after a user defined time delay) and the FAIL LED on the EXC Controller lights.
- If pump rotational overspeed is detected by the EXC Controller, the pump is stopped immediately and the FAIL LED on the EXC Controller lights.

If the FAIL LED lights, switch off the backing-pump immediately and vent the EXT Split Flow Pump. Once the EXT Split Flow Pump has stopped, rectify the cause of the failure (refer to [Section 5.5](#)), press the EXC Controller Start/Stop button to reset the Fail condition, and restart the EXT Split Flow Pump. If the pump is hot, allow sufficient time for it to cool before you restart it.

Note: Any references to LEDs and buttons do not apply to OEM versions of the EXC Controller i.e. EXC100L or EXC100.

5 Maintenance



WARNING

The EXT Split Flow Pumps are not to be serviced by the customer. Pumps requiring servicing should be returned to Edwards or serviced by a qualified Edwards engineer.



WARNING

Allow the pump-rotor to stop, then disconnect the controller before you remove the pump from your vacuum system for maintenance or fault-finding procedures.



WARNING

Do not remove the EXDC Controller/EXC Controller cable from the pump until the pump is completely at rest. To do so could expose personnel to hazardous voltage and potentially damage the EXDC/EXC Controller.

5.1 Introduction

The maintenance operations for the EXT Split Flow Pumps are described in the following sections. The ISX Inlet-Screen, the WCX Water-Cooler, the inlet-strainer and inlet-flange seals are available as spares (refer to [Section 7](#)). Fit the ISX Inlet-Screen as described in [Section 3.3.2](#). Fit the WCX Water-Cooler as described in [Section 3.6.3](#).

5.2 Bearing maintenance

When supplied, the pump contains sufficient lubricant to supply the bearings for life. No routine maintenance is therefore required between bearing replacements. The bearings are not user- serviceable. The bearings will need to be replaced when they reach the end of their service life. This is typically more than 20,000 hours, but may be less; this depends on the type of pumping duty on which the pump is used.

When the bearings need replacement, we recommend that you exchange your pump for a factory reconditioned replacement. Alternatively, you can send your pump to an Edwards Service Centre to have the bearings replaced.

When you return EXT Split Flow Pumps to Edwards Service Centres please use the procedure included at the end of this manual. However, the instruction to drain all fluids does not apply to the lubricant in the EXT Split Flow Pump oil-reservoirs.

5.3 Rotor life

The fatigue life of the EXT Split Flow Pump rotors is typically 40 000 to 50 000 cycles of acceleration from rest to full speed and then back to rest. As a precautionary measure, Edwards recommends that pumps are returned for a major service (rotor replacement) after 20 000 cycles or ten years, whichever occurs first.

5.4 Cleaning the pump



WARNING

Clean the external surfaces of the EXT Split Flow pumps in a well-ventilated location. When you use cleaning solutions and solvents to clean the pump, observe all precautions specified by the manufacturer. Avoid inhalation of any particulates which may be present in the pump.

CAUTION

Do not attempt to clean any parts of the EXT Split Flow pumps other than the external surfaces. Organic solvents may damage internal pump components. Do not use abrasive materials to clean any part of the pump.

If the inside of the EXT Split Flow pumps is contaminated, it may not be possible to achieve the specified ultimate vacuum, or pump-down time may increase. In these circumstances the pump must be returned to an Edwards Service Centre, where the pump will be dismantled and cleaned. Use the procedure given in the forms at the end of this manual to return the pump.

Use a cleaning solution which is suitable for the contaminants in the pump. You can use any organic solvent to clean the EXT Split Flow Pump, but we recommend that you use non-CFC solvents, such as isopropanol or ethanol.

For environmental reasons, keep wastage of cleaning solutions and solvents to a minimum.

5.5 Fault finding

Refer to [Table 7](#) for the possible causes of faults and for the recommended actions to rectify faults. [Table 7](#) is applicable to a basic, manually controlled pumping system with an EXC Controller configured for local (manual) operation.

Note that if you use an EXDC Pump Drive Module to control the EXT Split Flow Pump, or if you use an EXC Controller configured for remote operation to control the EXT Split Flow Pump, some of the checks and actions in [Table 7](#) may not apply to your system. Refer to the fault finding section of the instruction manual supplied with your EXDC Pump Drive Module or EXC Controller for further fault finding information.

Table 7 - Fault finding

Symptom	Check	Action
The impeller does not rotate. After pressing start - Fail LED not lit.	<p>Is the EXC Controller power LED lit?</p> <p>Is the EXC Controller Start/Stop LED flashing?</p> <p>Is the EXC Controller first speed indication LED lit?</p>	<p>If not, check that the electrical supply is on, check that the switch at the rear of the EXC Controller is on, check the fuse in the rear of the EXC Controller.</p> <p>If all of the above are OK then the EXC Controller is faulty. Consult Edwards or your supplier.</p> <p>If so, check that the correct links are made on the EXC Controller logic interface (refer to the instruction manual supplied with the EXC Controller).</p> <p>Check that any system interlocks are correctly made (refer to the instruction manual supplied with the EXC Controller).</p> <p>Check that the pump-to-controller lead is connected.</p> <p>If you have made all of the above checks and cannot identify the cause of the fault, consult Edwards or your supplier.</p> <p>If not, the EXC Controller is faulty. If lit, then the EXT Split Flow Pump is faulty. Consult Edwards or your supplier.</p>
The EXC Controller trips into Fail - at any speed.	Are the system interlocks correctly connected?	Ensure that the system interlocks do not open after the EXT Split Flow Pump has started.
The EXC Controller trips into Fail during the ramp-up and before 50% speed is reached.	<p>Is the inlet pressure too high? Is the backing pressure too high?</p> <p>Is the EXT Split Flow Pump running too hot?</p> <p>Does the rotor rotate freely?</p> <p>Is the timer set incorrectly?</p>	<p>If so, reduce the pumping load, or check for a gross leak into the system.</p> <p>Increase the cooling-water flow or decrease the water temperature or do both. You may need to add air-cooling to water-cooling. (Refer to Section 3 for maximum inlet pressure and cooling requirements). Check that external heat sources (such as system bakeout heaters) are not excessive.</p> <p>If not, the EXT Split Flow Pump bearings are damaged. Consult Edwards or your supplier.</p> <p>Increase the timer setting (refer to the instruction manual supplied with the EXC Controller). If the EXC Controller still trips into Fail consult Edwards or your supplier.</p>

Table 7 - Fault finding (continued)

Symptom	Check	Action
The EXC Controller trips into Fail after 50% speed has been reached - the first two speed LEDs are lit.	Is the pressure too high?	If so, reduce the pumping load or check for a gross leak into the system. If the high gas load is temporary, configure the EXC Controller to delay the Fail trip on 50% speed and set an appropriate delay time (refer to the instruction manual supplied with the EXC Controller).
	Is the EXT Split Flow Pump running too hot?	Increase the cooling-water flow or decrease the water temperature or do both. You may need to add air-cooling to water-cooling.
	Does the EXT Split Flow Pump rotor rotate freely?	If not, the EXT Split Flow Pump bearings are damaged. Consult Edwards or your supplier.
The EXC Controller trips into Fail - all the speed LEDs are lit.		Consult Edwards or your supplier.
System operating pressure cannot be reached.	Are any of the vacuum gauges contaminated?	If so, clean or replace them.
	Is the pumping speed insufficient (due to poor conductance between the pump and the gauge or too large a chamber)?	Increase the conductance or reduce the volume.
	Is the interstage inlet pressure > 0.2 mbar (20 Pa)?	If the interstage inlet pressure is too high, inlet pressure at the turbomolecular inlet is reduced; ensure that the interstage inlet pressure is < 0.2 mbar (20 Pa).
	Is the backing pressure < 12 mbar (1200 Pa)?	Check for backing line leaks. If the backing pressure is too high, you may need a larger backing pump.
	Is the high-vacuum area of the system contaminated?	If so, clean the high-vacuum system.
The EXT Split Flow Pump is very noisy or there is excessive vibration or both.	Check the rest of your system for leaks and contamination.	If found, clean the contaminated areas and repair the leaks.
	Is the pump rotational speed the same as the resonant frequency of the attached system?	If so, change the natural frequency of your system.
	Is the vibration being transmitted from the rotary pump?	If so, fit flexible bellows or a vibration isolator in the backing line.
	Is the noise irregular and getting progressively worse?	If so, a bearing is defective. Consult Edwards or your supplier.
	Is the EXT Split Flow Pump making a constant high-pitched noise?	If so, the rotor is out of balance. Consult Edwards or your supplier.
None of the above.	-	Consult Edwards or your supplier.

6 Storage and disposal

6.1 Storage

Use the following procedure to store the pump.

1. Place protective covers over the main inlet, side inlet, outlet, interstage (Hi variants only) and vent ports.
2. Place the pump in its packing materials. For fastest pump-down when the pump is put back into service, seal the pump inside a plastic bag together with a suitable desiccant.
3. Store the pump in cool, dry conditions until required for use. When required, prepare and install the pump as described in [Section 3](#).
4. Keep the pump upright at all times to prevent the drainage of oil from the bearing reservoir.
5. Avoid long-term storage if possible. When long-term storage is necessary, the pump should be set up and run for at least eight hours every six months.

6.2 Disposal



WARNING

In the unlikely event of a failure of the pump rotor, dust can be generated from the carbon fibre reinforced components.
In this event, use appropriate Personal Protective Equipment when handling and disposing of the pump, and ensure that all pump inlets and outlets are capped off before disposal.

Dispose of the EXT Split Flow Pump and any components and accessories safely in accordance with all local and national safety and environmental requirements.

Particular care must be taken with any components which have been contaminated with dangerous process substances.

Take appropriate action to avoid inhalation of any particulates which may be present in the pump. Do not incinerate the pump. The pump contains phenolic and fluorosilicone materials which can decompose to very dangerous substances when heated to high temperatures.

This page has been intentionally left blank.

7 Service, spares and accessories

7.1 Introduction

Edwards products, spares and accessories are available from Edwards companies in Belgium, Brazil, Canada, France, Germany, Hong Kong, Italy, Japan, Korea, United Kingdom, USA and a worldwide network of distributors. The majority of these employ service engineers who have undergone comprehensive Edwards training courses.

Order spare parts and accessories from your nearest Edwards company or distributor. When you order, please state for each part required:

- Model and item number of your equipment.
- Serial number (if any).
- Item number and description of the part.

7.2 Service

Edwards products are supported by a worldwide network of Edwards Service Centres. Each Service Centre offers a wide range of options including: equipment decontamination; service exchange; repair; rebuild and testing to factory specifications. Equipment which has been serviced, repaired or rebuilt is returned with a full warranty.

Your local Service Centre can also provide Edwards engineers to support on-site maintenance, service or repair of your equipment.

For more information about service options, contact your nearest Service Centre or other Edwards company.

7.3 Spares

7.3.1 ISX inlet-screens

Inlet-screens are fitted to your pump as supplied to prevent damage from the entry of debris into the pump. The Item Numbers of replacement inlet-screens are given below. Select the inlet-screen according to the pump inlet-flange size.

Note: Kits contain 10 screens each.

Table 8 - ISX inlet-screens

Flange size	Inlet-screen	Item Number
DN100ISO-K	ISX100	B736-00-122
DN100ISO-K	ISX100 (coarse)	B756-40-813
DN63ISO-K	ISX63	B722-00-116
DN100ISO-K	ISO100 trapped O-ring intergrated coarse inlet screen	B756-40-820
DN100ISO-K	ISO100 trapped O-ring with integrated fine inlet screen	B756-40-819
	C10523093	B756-30-991

7.3.2 Inlet-strainer (interstage pumps only)

The EXT70/200Hi and EXT200/200Hi Split Flow Pumps are supplied with inlet-strainers for the interstage- port. The Item Number of a replacement inlet-strainer is given below.

Table 9 - Inlet-strainer (interstage pumps only)

Flange size	Item Number
NW25ISO-K	A223-05-067

7.3.3 Inlet-flange seals

EXT Split Flow Pumps are supplied with inlet seals. The Item Numbers of replacement seals are given below.

Table 10 - Inlet-flange seals

Flange size	Inlet-flange seal	Item Number
DN100ISO-K	ISO100 trapped o-ring, fluoroelastomer	B271-58-171
DN63ISO-K	ISO63 trapped o-ring, fluoroelastomer	B271-58-170

7.4 Accessories

7.4.1 Installation

The accessories available for use with the EXT Split Flow Pumps are described in the following sections. Figure 2 shows how the accessories are fitted to an EXT Split Flow Pump.

7.4.2 EXDC drive modules

Fit an EXDC Drive Module as an alternative to an EXC Controller and pump-to-controller cable.

Table 11 - EXDC drive modules

Drive Module	Item Number
EXDC160 24 V 45 deg	D396-46-600*
EXDC160 80 V	D396-41-000

* Pump system originally supplied with D396-46-510 (unpacked)

7.4.3 EXC controllers

The Edwards EXC Controllers provide the facilities necessary for operating a pumping system based on an EXT70/200H, EXT70/200Hi, EXT200/200H or EXT200/200Hi Split Flow Pump. The Item Numbers of the EXC Controllers are given below.

Table 12 - EXC controllers

Controller	Voltage	Item Number
EXC100E	90 - 264 V a.c.	D396-20-000
EXC100L	90 - 264 V a.c.	D396-22-000
EXC120	90 - 264 V a.c.	D396-16-000
EXC300	90 - 132/180 - 264 V a.c.	D396-14-000

7.4.4 Pump-to-controller cables

You must fit a pump-to-controller cable between an EXC Controller and the EXT Split Flow Pump. A cable is not supplied with the EXT Split Flow Pump or the EXC Controller (except EXC100L). The following cables are available:

Table 13 - Pump-to-controller cable

Cable	Length	Item Number
Pump-to-controller	1 m	D396-18-010
Pump-to-controller	3 m	D396-18-030
Pump-to-controller	5 m	D396-18-050

7.4.5 EXT water cooling block assembly

A water-cooler can be fitted to the EXT Split Flow Pump. However please refer to [Section 2.4](#) to check the stability of the cooling-water supply:

Table 14 - EXT water cooling block assembly

Water-cooler	Item Number
WCX250M	B735-01-164

7.4.6 TAV vent-valve and vent-port adaptor

Two solenoid-operated vent-valves are available for system venting. The valves are 24 V d.c., normally-open, and can be driven automatically from the EXC Controller. The solenoid-valve is fitted in place of the manual-valve, or alternatively can be fitted with an adaptor (supplied with the valve) and be used with any suitable NW10 flanged port on your vacuum system. The vent-port adaptor allows the vent-port or the purge-port to be used with any suitable NW10 fitting.

Table 15 - TAV vent-valve and vent-port adaptor

Product	Item Number
TAV5 vent-valve	B580-66-010
TAV6 vent-valve	B580-66-020
NW10-1/8 inch BSP male adaptor	B580-66-011
NW10-1/8 inch BSP male extended vent-port adaptor	B580-66-028

7.4.7 ACX air-cooler

An ACX air-cooler can be fitted to the EXT Split Flow Pump. However, please refer to [Section 2](#) to check the suitability of air-cooling in a particular application.

Table 16 - ACX air-cooler

Air-cooler	Item Number
ACX250H	B580-53-160

7.4.8 VRX vent-restrictor

Use a VRX fixed orifice vent-restrictor to restrict the flow of vent gas into the EXT Split Flow Pump. Refer to Section 3.4 for information on the selection of the correct VRX Vent-restrictor.

Table 17 - VRX vent-restrictor

Vent-restrictor	Orifice diameter	Item Number
VRX10	0.1 mm	B580-66-021
VRX20	0.2 mm	B580-66-022
VRX30	0.3 mm	B580-66-023
VRX50	0.5 mm	B580-66-024
VRX70	0.7 mm	B580-66-025

Figure 8 - Installation of optional accessories

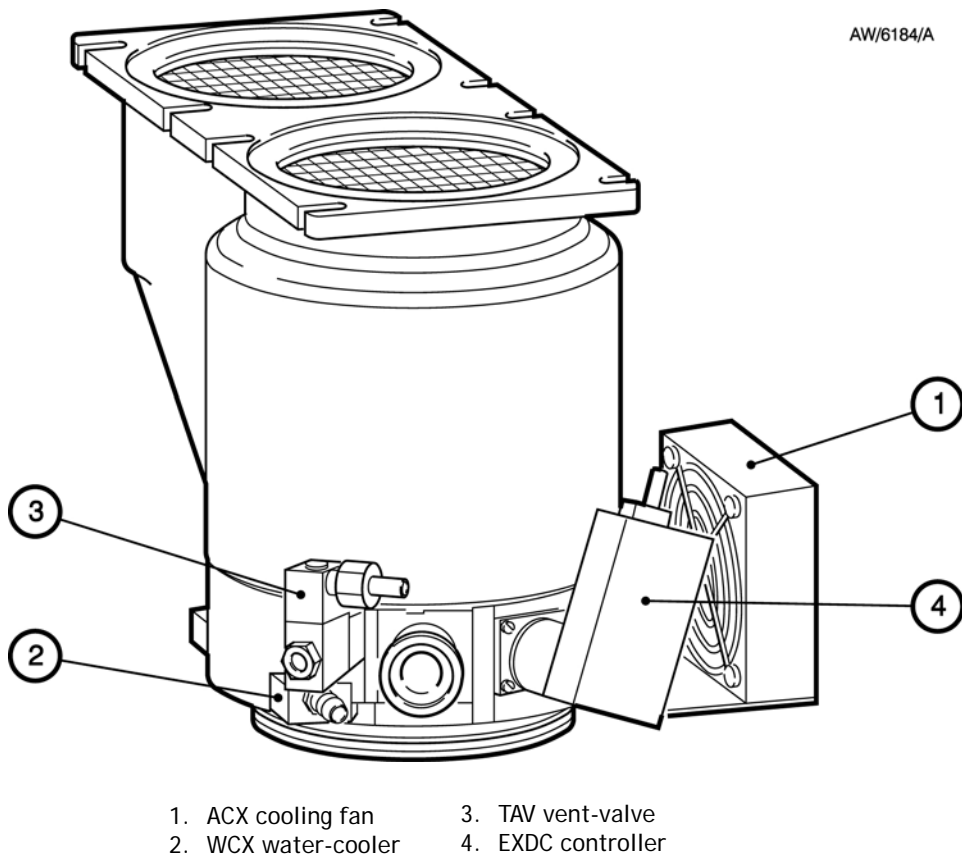

Index

A

Accessories	30
ACX Air-Cooler	31

B

Backing connection	17
Bearing maintenance	23

C

Cautions	1
Cleaning the pump	24
Connection to the vacuum system	14
Cooling	19

D

Disposal	27
----------------	----

E

Electrical installation	18
EXC Controllers	19, 22, 30
EXDC Controllers	19, 22
EXDC Drive Modules	30
EXT Water cooling block assembly	31
EXT200/200H	1
EXT200/200Hi	8
EXT70/200H	1

F

Fault finding	24
Forced-air cooling	20

I

Inlet connection and orientation	16
Inlet-flange seals	30
Inlet-screens	16
Inlet-strainer	30
Installation	13
Interstage connection	18
ISX Inlet-Screens	29

M

Maintenance	23
Materials exposed to gases pumped	9
Mechanical fixing	15

P

Pumping media	3
Pump-to-controller cables	31

R

Rotor life	23
------------------	----

S

Safety interlocks and control system	22
Scope and definitions	1
Service	29
Shut-down	21
Spares	29

T

TAV Vent-valve and vent-port adaptor	31
Typical installation	13

U

Unpack and inspect	13
--------------------------	----

V

VRX Vent-restrictor	32
---------------------------	----

W

Warnings	1
Water-cooling	5, 20

This page has been intentionally left blank.