



Atlas Copco DZS 065V, 150V, 300V

Technical Specifications

Type	Nominal displacement		Ultimate vacuum level 'V' version			Permissible ambient temperature range		Inlet connection size	Outlet connection size	Shaft power	
	m ³ /h	cfm	mbar(a)	"Hg Vac	Torr	°C	°F	BSP	BSP	kW	hp
DZS 065V - 50 Hz	65	38	50	28.3	375	0 to 40	32 to 104	G 1 1/4"	G 1 1/4"	1.8	2.0
DZS 065V - 60 Hz	78	47	50	28.3	375	0 to 40	32 to 104	G 1 1/4"	G 1 1/4"	2.2	3.0
DZS 150V - 50 Hz	150	88	50	28.3	375	0 to 40	32 to 104	G 1 1/4"	G 1 1/4"	3.7	5.0
DZS 150V - 60 Hz	180	104	50	28.3	375	0 to 40	32 to 104	G 1 1/4"	G 1 1/4"	3.7	5.0
DZS 300V - 50 Hz	300	176	140	25.8	105	0 to 40	32 to 104	G 2"	G 1 1/4"	6.2	8.3
DZS 300V - 60 Hz	360	208	140	25.8	105	0 to 40	32 to 104	G 2"	G 1 1/4"	7.5	10.0

*Pumping speed based on air at 20°C. Tolerance +/-10%.
60Hz Versions supplied with NPT adaptors*

Features & Benefits

- low lifecycle costs
- low noise levels
- long life bearings & seals
- easy maintenance & cleaning
- best in class power consumption
- unrivalled ultimate vacuum level
- cool running & simple air cooling
- stainless steel corrosion resistant claws
- innovative construction materials & coatings
- modular, compact design with small footprint
- variable speed drive compatible



Applications

- hospital central systems • CNC routing • pneumatic conveying
- packaging lines • moulding machines • drying processes
- central vacuum supply systems



PROVAC

SALES

PHONE: 831-462-8900

FAX: 831-462-3536

WWW.PROVAC.COM

Atlas Copco DZS 065V, 150V, 300V Pumping Curves

DZS 065 V

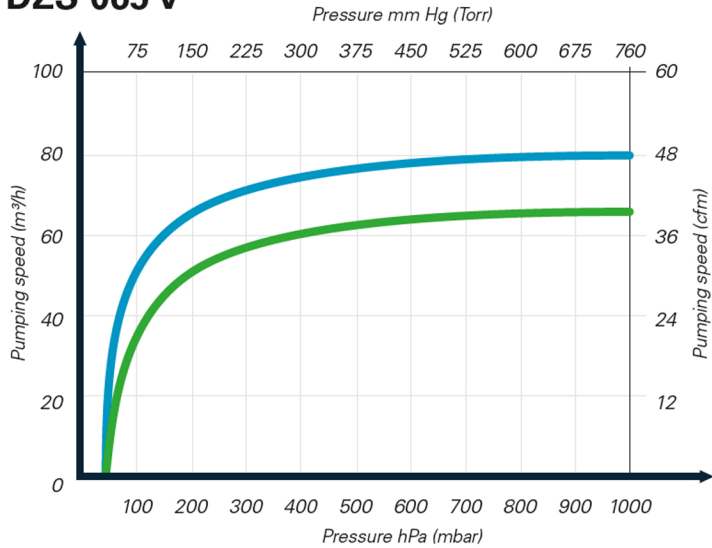

DZS 150 V

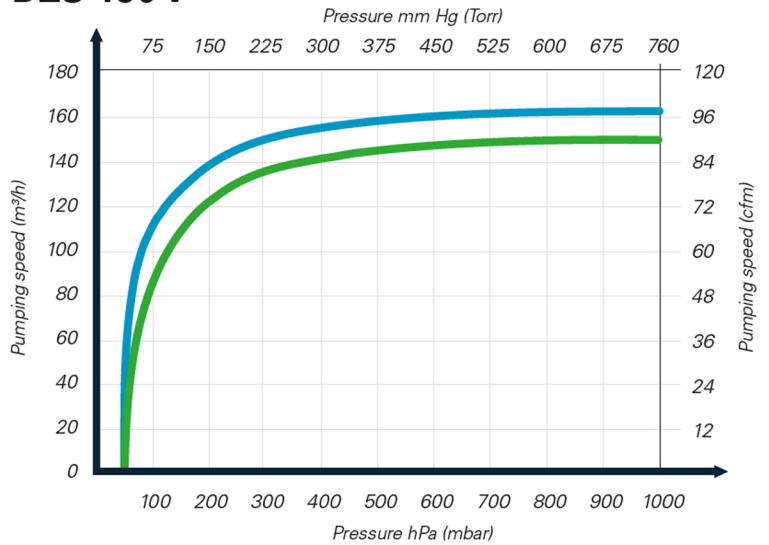

DZS 300 V

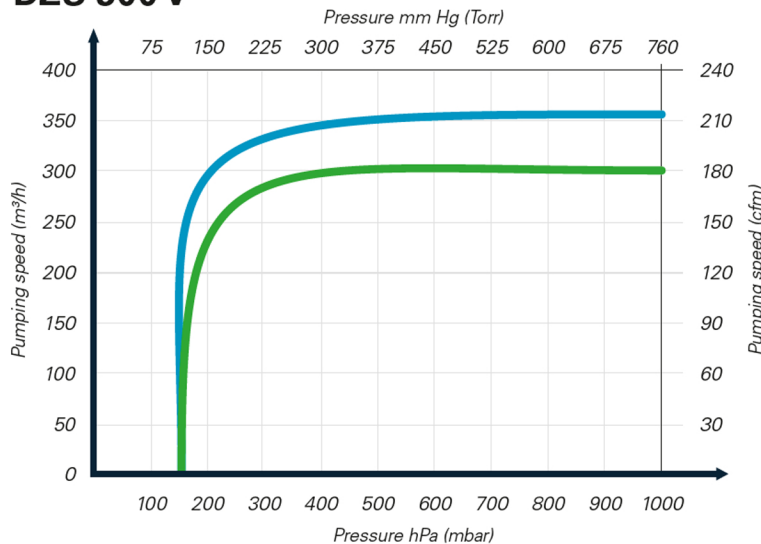

● 60 Hz operation

● 50 Hz operation



PROVAC

SALES

PHONE: 831-462-8900

FAX: 831-462-3536

WWW.PROVAC.COM

Atlas Copco DZS 065V, 150V, 300V Dimensions

DZS 065V, DZS 150V

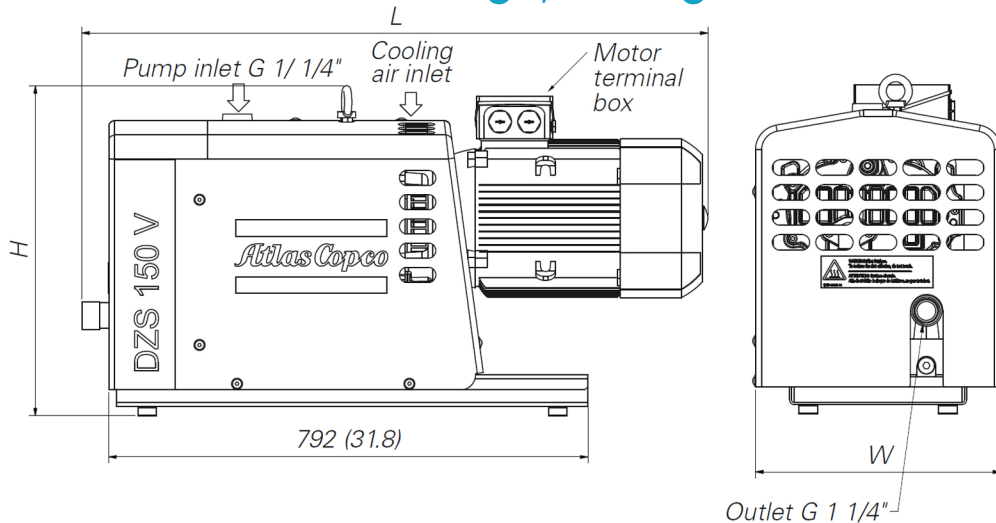

DZS 300V

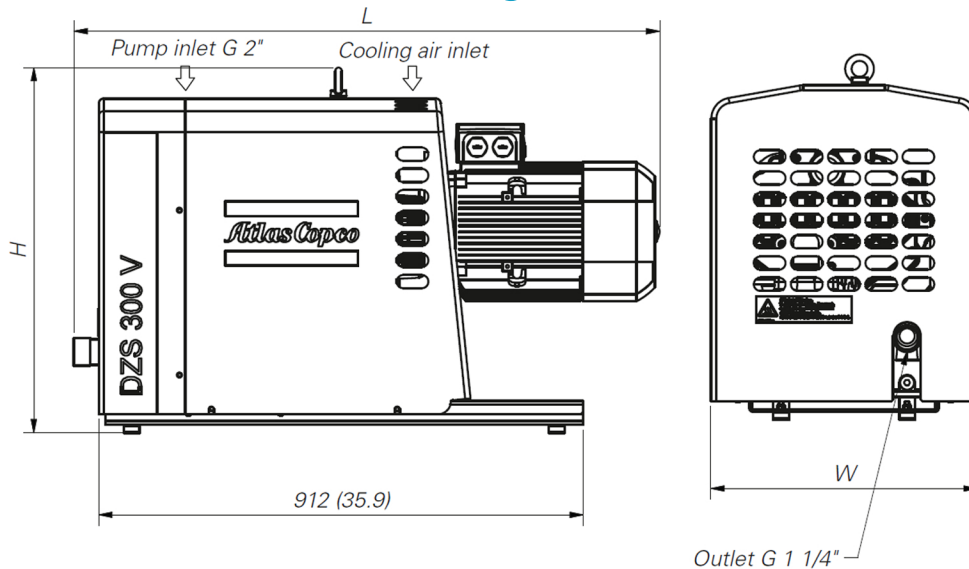

Type	Length		Width		Height		Weight	
	mm	in	mm	in	mm	in	kg	lbs
DZS 065 V	920	36.2	394	15.5	545	21.4	120	265
DZS 150 V	934	36.7	394	15.5	545	21.4	160	353
DZS 300 V	1110	43.7	500	19.6	688	27	252	555
DZS 150 P	1090	42.9	416	16.4	673	26.5	196	432
DZS 300 P	1360	53.5	500	19.8	802	31.5	300	661

Pumping speed based on air at 20°C. Tolerance +/-10%.
60Hz Versions supplied with NPT adaptors

PROVAC SALES, INC. 3131 SOQUEL DRIVE, SOQUEL CA 95073