

Oil Diffusion Pumps

with Energy Efficiency Control

DIP 20 000

DIP 30 000

DIP 50 000

Operating Instructions 300487317_002_C7

Part Nos.

117 83

222 30 /TE /Vxxx /VxxxTE

222 35 /TE /Vxxx /VxxxTE

222 40 /TE /Vxxx /VxxxTE

500 148 /312 /665 /728 /882

501 008 /041 /074 /097 /779

502 397 /959Vxxx

503 050Vxxx /299Vxxx

503 612Vxxx /613Vxxx

503 647Vxxx /648Vxxx

504 096Vxxx



Contents

	Page
0 Safety Information	5
Explanation of Safety Symbols	5
0.1 Mechanical Hazards	6
0.2 Electrical Hazards	7
0.3 Thermal Hazards	8
0.4 Danger through substances and materials that are transported, used or expelled by the vacuum pump	9
1 Description	11
1.1 Design and Function	11
1.2 Supplied Equipment	12
1.3 Technical Data	13
1.4 Ordering Information	17
1.5 Overview of Pump Fluids	18
2 Transport and Storing	19
3 Installation	21
3.1 Conforming Utilisation	21
3.1.1 Non-conforming Utilisation	21
3.1.2 Risk of Damaging the Pump	21
3.2 Ambient Conditions	22
3.3 High-vacuum Connection	23
3.4 Forevacuum Connection	24
3.5 Coolant Connections	26
3.5.1 Water Quality	27
3.6 Electrical Connections	28
3.6.1 Connecting the Heaters	29
3.6.2 Connecting Monitoring Components (optional)	38
3.7 Pump Fluid	39

4	Operation	40
4.1	Media Compatibility	40
4.2	Start-up	42
4.3	Operation	43
4.3.1	DIP without Energy Efficiency Control (EEC)	45
4.3.2	DIP with EEC	46
4.3.2a	Adjusting the Oil temperature	46
4.3.2b	Changing the Control Unit's Display	47
4.3.2c	Safety System	48
4.3.2d	Changing the Language Settings	48
4.3.2e	Notes	50
4.3.2f	Modbus	51
4.3.2g	Web Server	53
4.4	Switching Off/Shutting Down	56
5	Maintenance	59
5.1	Leybold Service	60
5.2	Checking the Pump Fluid Level	60
5.3	Topping up Pump Fluid	61
5.4	Exchanging the Pump Fluid	63
5.5	Cleaning the Pump	64
5.5.1	Dismantle Pump	64
5.5.2	Cleaning the Pump	64
5.5.3	Oil Level Sight Glass	65
5.5.4	Assembling the Pump	65
5.5.5	Cleaning the Cooling Coils	66
5.6	Replacing the Heating Cartridges	67
6	Troubleshooting	72
7	Wearing Parts and Original Spare Parts	73
8	Waste Disposal	75
	Appendix	77
	EU Declaration of Conformity	78
	EC Declaration of Incorporation	79

Original installation and operating instructions.

Safety information



NOTICE

Obligation to Provide Information

Before installing and commissioning the DIP, carefully read these Operating Instructions and follow the information so as to ensure optimum and safe working right from the start.

The Leybold **DIP** pumps has been designed for safe and efficient operation when used properly and in accordance with these Operating Instructions. It is the responsibility of the user to carefully read and strictly observe all safety precautions described in this section and throughout the Operating Instructions. The pump **must only be operated in the proper condition and under the conditions described in the Operating Instructions**. It must be operated and maintained by trained personnel only. Consult local, state, and national agencies regarding specific requirements and regulations. Address any further safety, operation and/or maintenance questions to our nearest office.

“Trained personnel” for the operation of this pump are

- skilled workers with knowledge in the fields of mechanics, electrical engineering and vacuum technology, and
- personnel specially trained for the operation of vacuum pumps.

DANGER



DANGER indicates an imminently hazardous situation which, if not avoided, will result in death or serious injury.

WARNING



WARNING indicates a potentially hazardous situation which, if not avoided, could result in death or serious injury.

CAUTION



CAUTION indicates a potentially hazardous situation which, if not avoided, could result in minor or moderate injury.

NOTICE



NOTICE is used to notify users of installation, operation, programming or maintenance information that is important, but not hazard related.

We reserve the right to alter the design or any data given in these Operating Instructions. The illustrations are not binding.

Retain the Operating Instructions for further use.

Safety information

0 Safety Information

Explanation of Safety Symbols



General warning sign



Warning - automatic start-up!



Warning - slipping hazard!



Warning - electrical voltage!



Warning - toxic substances!



Warning - hot surface!



Warning - explosive substances!



General mandatory sign

Safety information

DANGER



0.1 Mechanical Hazards

1 Ejection of parts through bursting of the vacuum system due to excessive pressure, caused by errors like malfunction at the gas inlet into the vacuum system

When venting the DIP pump at > 100 °C danger of explosion!

The pump must be securely locked during operation.

The DIP pump may be vented only if the pump fluid temperature is < 100 °C.

Any rearward venting must be ruled out. The cooled pump should be vented from the high vacuum side.

Turn off the cooling water supply only once the DIP pump has cooled down to < 100 °C.

DIP pump operation with closed high vacuum and fore-vacuum side and simultaneously switched off cooling water supply is a dangerous condition and must be reliably ruled out (e.g. by locking circuit).

DANGER



2 Loss of stability during transport

Uncontrolled movement through incorrect fastening/raising/lifting of the pump system.

Use all crane eyes when lifting the pump body. Pay attention to the centre of gravity!

Transportation flanges (blank flanges) and claws may be used only for transportation purposes; they are not suitable for the assembly of the pumps in systems.

Uncontrolled movement through inertia of mobile pump systems (wheels / mobile frame)

Mount and move mobile pumps with roles only on flat, solid, horizontal surfaces.

Pay attention to appropriate slow speed when moving the pump.

CAUTION



3 Getting dragged into the vacuum system

Do not operate the pump system with opened intake and outlet port.

During installation first connect the system mechanically via the inlets and outlets and only then make the electrical connections.

4 Ejection of parts through implosion of a part of the pump or the pump system

If the boiler overheats due to too little or no oil or too little cooling water flow, the boiler can implode.

The water cooling system may not be interrupted in the case of a malfunction.

Observe the installation regulations.

5 **Hazard of slipping, tripping or falling due to oil leakage from the pump**

Depending on the work process, oil may escape from the pump.

Check the pump for any oil that has run out. Take appropriate security measures.

CAUTION



6 **Hazards that may occur through independent restart of a pump after a shutdown due to an error**

Connect the pump in such a way that if a monitoring element is triggered (thermostat, thermal protective switch, water flow guard) it does not automatically restart after the inadmissible operating condition has ended.

CAUTION



0.2 Electrical Hazards

1 **Electric shock through direct or indirect contact of live parts**

Electric shock by touching active electrical components. Voltage spreading through incorrect electrical connection.

The electrical connection may be carried out only by a trained person. Observe the national regulations in the country of the user, e.g. for Europe EN 50110-1.

A protective earth check between the PE connection and every touchable part that requires a protective connection, must be carried out before initial operation. Do this for the test current, use 10A DC or AC (RMS), while 0.1 Ohm impedance must not be exceeded.

The temperature sensor (Pt 100 heating cartridge temperature) may take on voltage that is dangerous to touch. The operator must take suitable precautions for protection in case of indirect touching. For example, a temperature transducer with double or reinforced isolation may be used for this purpose.

Connect a second protective earthing conductor.

There are hazardous voltages present on the mains cables (danger to life).

Before carrying out maintenance or service work on the product, take it off the mains supply. After mains power off, wait for 5 minutes!

DANGER



Safety information

DANGER**2 Loss of power supply**

Explosion hazard due to uncontrolled venting!

The valves must be closed in the event of a power failure.

Air infiltration in an operation-ready, warm diffusion pump are a dangerous condition and must be reliably ruled out.

If electro-pneumatically propelled high- and fore-vacuum valves are used, these must be used shut in the specification “de-energised” and “unpressurised”. Also for these valves, the ventilation of a ready-to-operate, hot diffusion pump must be ruled out through appropriate latch circuits.

The components must be connected correctly and properly. Electrical safety examinations, in particular the insulation and protective grounding conductor examination, must be carried out.

CAUTION**3 High electrical fault currents due to moisture absorption by mineral insulating material of the heating elements**

The hygroscopic insulation of the heating element could lead to a burn-out of the heater cartridge. Risk occurs through longer shut-off cycles and humid ambient conditions.

Take note of the installation instructions for the replacement and connection of the heater cartridge.

Check stock before changing/inserting (measured value: 49 to 55 ohms) and degas if necessary.

In case of standstill, check heater cartridge after one year.

CAUTION**0.3 Thermal Hazards****1 Burns from touching hot surfaces**

Burning of fingers, hands, arms on hot surfaces up to +140°C. Hazard of burns with open covers.

Handle the pump only in ventilated and cooled down condition. Wear suitable protective equipment. Take note of the cooling time after switching off.

2 Scalding by touching hot equipment or lubricants

Risk of scalding when opening the hot pump through pump fluid steam

Only open fluid drain port or inlet port if the pump is vented and is cooled down to room temperature.

Let cooling water pipes cool down before removing and then shut off the feed line.

Wear suitable protective equipment.

0.4 Danger through substances and materials that are transported, used or expelled by the vacuum pump

1 Danger through expulsion of transported toxic gases/vapours. Fire or explosion in case of transport or ejection of flammable gases/vapours, oxidizing agents or pyrophoric gases

Transported process gases can escape out of the exhaust pipe and from leaking areas of the vacuum system.

Transport of toxic gases/vapours, flammable gases/vapours, oxidizing agents or pyrophoric gases is generally excluded.

In its standard version, the pump system is not suitable for operation in ex-zones.

The operator is responsible for the assessment of the hazard potential of the process media and/or mixtures. For this purpose, the operator must perform a risk or hazard assessment. The operator must take appropriate measures to ensure that there is no danger to man and the environment.

Do not use any easily flammable materials near the hot pump area.

2 Hazards through emission of harmful gases/vapours

During the start-up and the new installation of the heater cartridge, smoke and an unpleasant smell may develop. Therefore, turn on new pumps and pumps after successful servicing of the heater cartridges only in well-ventilated areas. Avoid direct contact with the smoke or gases that can develop during start-up.

3 Danger as a result of contact with toxic decay/reaction products of lubricants, equipment or pumped substances during the maintenance of the pump

In the event of servicing, there may be deposits in the pump.

The pumping of toxic gases and vapours is basically excluded.

The operator is responsible for the assessment of the hazard potential of the process media and/or mixtures. For this purpose, the operator must perform a risk or hazard assessment. The operator must take appropriate measures to ensure that there is no danger to man and the environment.

For this purpose, we recommend that the pump is flushed for a longer time with inert gas before opening. Wear appropriate protective clothing (gloves, goggles, respiratory protection, personal protective equipment).

Avoid body contact with plant oil, process residues and contaminated surfaces. Perform maintenance in preferably clean, dry and well-ventilated rooms.

DANGER



DANGER



Safety information

4 **Danger as a result of contact with toxic decay/reaction products of lubricants, equipment or pumped substances during the maintenance of the pump**

Vacuum pumps which are operated with the lubricant Perfluorinated Polyether (PFPE) may in the case of thermal decomposition release toxic and corrosive gases.

Wear appropriate protective clothing (gloves, goggles, respiratory protection, personal protective equipment).

Avoid body contact with plant oil, process residues and contaminated surfaces. Perform maintenance in preferably clean, dry and well-ventilated rooms.



Do not smoke with PFPE on your fingers.

1 Description

The pumps in the DIP series are high-vacuum pumps ($<10^{-2}$ mbar). They are always operated in conjunction with forevacuum pumps.

The DIP series pumps are water cooled and utilize the oil diffusion principle in their operation. They are employed in high-vacuum technology to evacuate vacuum chambers.

They achieve their highest pumping speeds in pressure ranges from 10^{-2} to 10^{-7} mbar.

1.1 Design and Function

The diffusion pumps in the DIP series comprise the following component assemblies:

- Water-cooled pump housing with high-vacuum, and forevacuum connection flanges
- Nozzle assembly
- Vaporization chamber with heating elements
- Cold cap baffle
- Forevacuum baffle
- Energy Efficiency Control or electrical junction box

The DIP pumps are fitted with a four-stage nozzle system made of light-alloy metal and with an internal heating system comprising heating cartridges and mounting wells to which heat diffusion fins are soldered. The mounting wells are made of stainless steel and are welded vacuum-tight in the pump body, in a horizontal position.

The housing for the DIP pump is made of standard grade steel; the high-vacuum connection flange and the forevacuum connection are made of stainless steel (alloy 1.4301), the cooling coils of copper, and the cold cap baffle of nickel-plated copper.

The heat diffusion fins are made of copper and are only partially immersed in the pump fluid in the vaporization chamber.

The section of the heat diffusion fins immersed in the pump fluid is dimensioned so that that intense but surge-free vaporization of the pump fluid is achieved.

The sections of the heat dissipation fins located above the level of the pump fluid apply additional energy to the pumping vapor.

To protect the heating element, a thermostat sensor is attached to a heat diffusion fin which protrudes from the fluid; this will switch off the pump's heaters as soon as the temperature set at the safety thermostat is exceeded.

The sensor has to be installed into the system control by the customer so that it will safely switch off the power.

The heating cartridges can be easily replaced when required. It is not necessary to dismantle the pump to do so.

Nozzle system

Heat diffusion fins

Thermostat

NOTICE



Heating cartridges

Description

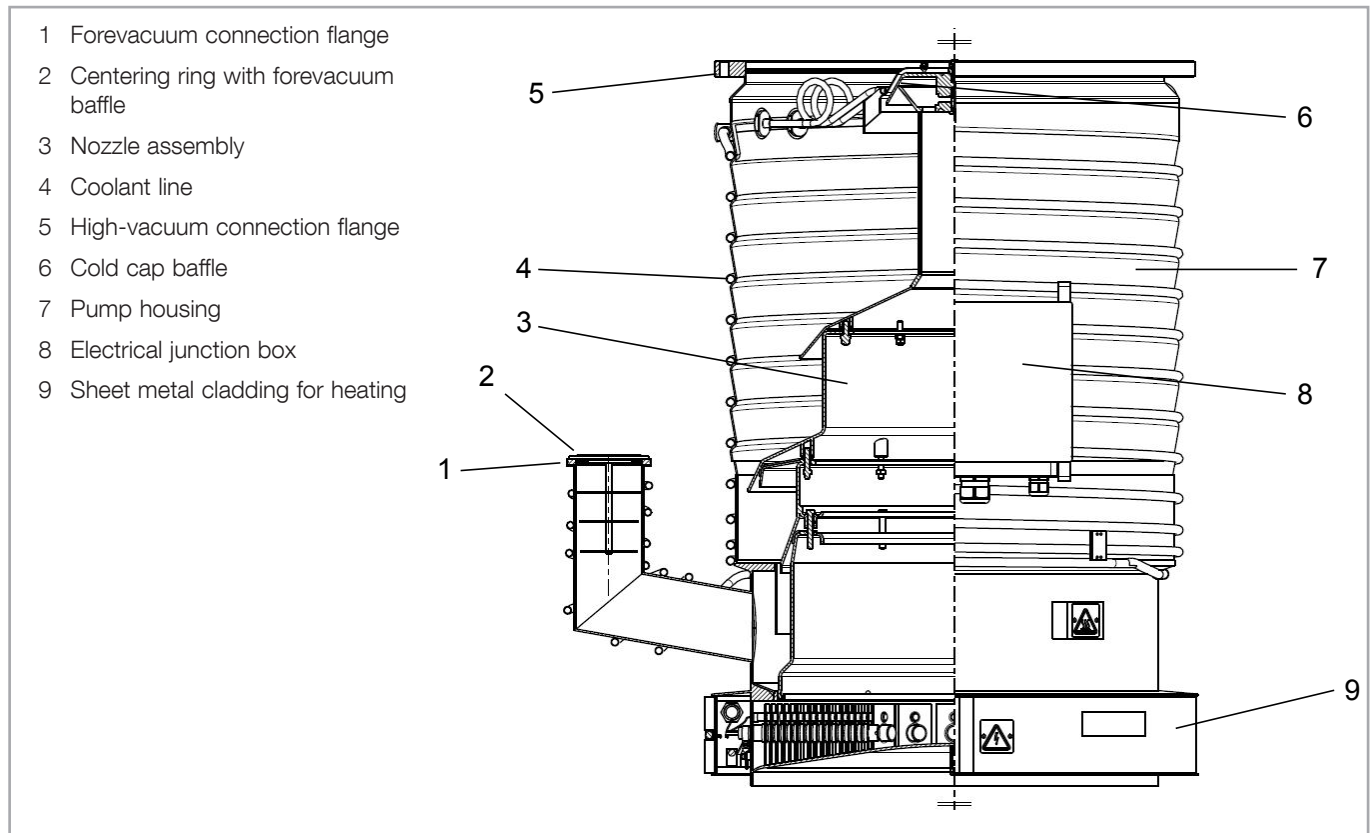

Fig. 1 Section through a model DIP 20 000 diffusion pump with junction box; other models similar (cf. Fig. 3)

Cold cap baffle

To prevent fluid from flowing back into the vacuum vessel, the DIP series pumps are fitted with a water-cooled cold cap baffle in the area of the intake port.

A water-cooled forevacuum baffle located on the forevacuum side effectively prevents fluid being swept into the forevacuum unit.

1.2 Supplied Equipment

All DIP pumps are shipped from the factory without pump fluid installed.

Included as standard equipment with the pump are

- centering ring, O-ring and outer ring for the high-vacuum flange,
- centering ring with insert for forevacuum baffle, O-ring and outer ring for the forevacuum flange.

The high-vacuum and forevacuum flanges are closed with shipping flanges and claws. The insides of the pumps have been cleaned; they are evacuated prior to shipment.

1.3 Technical Data

		DIP 20 000	DIP 30 000	DIP 50 000
High-vacuum connection	DN	630 ISO-F	800 ISO-F	1000 ISO-F
Forevacuum connection	DN	100 ISO-K	160 ISO-K	160 ISO-K
Pumping speed for hydrogen < 10 ⁻⁴ mbar air ¹⁾ < 1 · 10 ⁻⁴ mbar	l · s ⁻¹	20 000 16 000	30 000 24 500	50 000 41 000
Working range	mbar		< 10 ⁻² - 10 ⁻⁷	
Ultimate total pressure ²⁾	mbar		< 5 · 10 ⁻⁷	
Max. permissible forevacuum pressure	mbar		6 · 10 ⁻²	
Pump fluid fill, min./max.	l	7 / 11	10 / 15	15 / 25
Line power supply ⁵⁾		(± 10 %)	(± 10 %)	(± 10 %)
Standard, 50/60 Hz	V	230/400 ~ 3 Ph Δ/Y	230/400 ~ 3 Ph Δ/Y	230/400 ~ 3 Ph Δ/Y
Special, 50/60 Hz	V	460 ~ 3 Ph Δ	460 ~ 3 Ph Δ	460 ~ 3 Ph Δ
Heating power	kW	12	18	24
Heating cartridges		12	18	24
Warm-up period	min	< 25	< 30	< 30
Coolant (minimum) for the pump ³⁾	l · h ⁻¹	600	900	1500
for the cold cap baffle	l · h ⁻¹	80	80	150
Number of cooling circuits (including cold cap baffle)		2	3	3
Coolant connection				
Pump	G	1/2"	1/2"	1/2"
Cold cap baffle	G	3/8"	3/8"	3/8"
Weight, approx.	kg	172	296	560
Recom. forevacuum pumps ⁴⁾				
at working pressures > 10 ⁻⁴ mbar	mbar	SV 200 + W 501	SV 300 + W1001	SV 630 + W2001
at working pressures < 10 ⁻⁴ mbar	mbar	SV 100 + W 251	SV 300 + W 251	SV 300 + W 501
as supporting (holding) pump		D 65B	D 65B	D 65B
IP Code ⁶⁾		20	20	20
(control cabinet)		65	65	65

1) Measured as per DIN 28 427 using LVO 500 normal as the pump fluid.

2) Measured as per DIN 28 427 using LVO 500 normal as the pump fluid. When using the LVO 520 pump fluid and FPM (fluoroelastomer) gaskets, the DIP pumps with water-cooled baffles will achieve pressures below 1·10⁻⁷ mbar following suitable bake-out procedures.

3) The coolant water volume is referenced to ΔT = 10 K. The discharge temperature should normally not exceed 50 °C. Depending on the application, the discharge temperature can also be set higher. However, it must be ensured that the corresponding coolant lines are suitable for these temperatures.

4) Single- and two-stage rotary vane pumps (TRIVAC; SV) from our line of forevacuum pumps in conjunction with roots pumps (RUVAC) in pumping systems.

5) The EEC is connected both with a load voltage, and a control voltage (of 24V ±15%, 50/60Hz, 50VA, 6A or 230V ±15 % 1 ph). Both voltages will be disconnected safely from the mains via the EPO / main switch.

6) The control unit is designed and manufactured to comply with a degree of contamination 2 and an overvoltage category 2. Leybold recommends to connect an existing neutral conductor.

Description

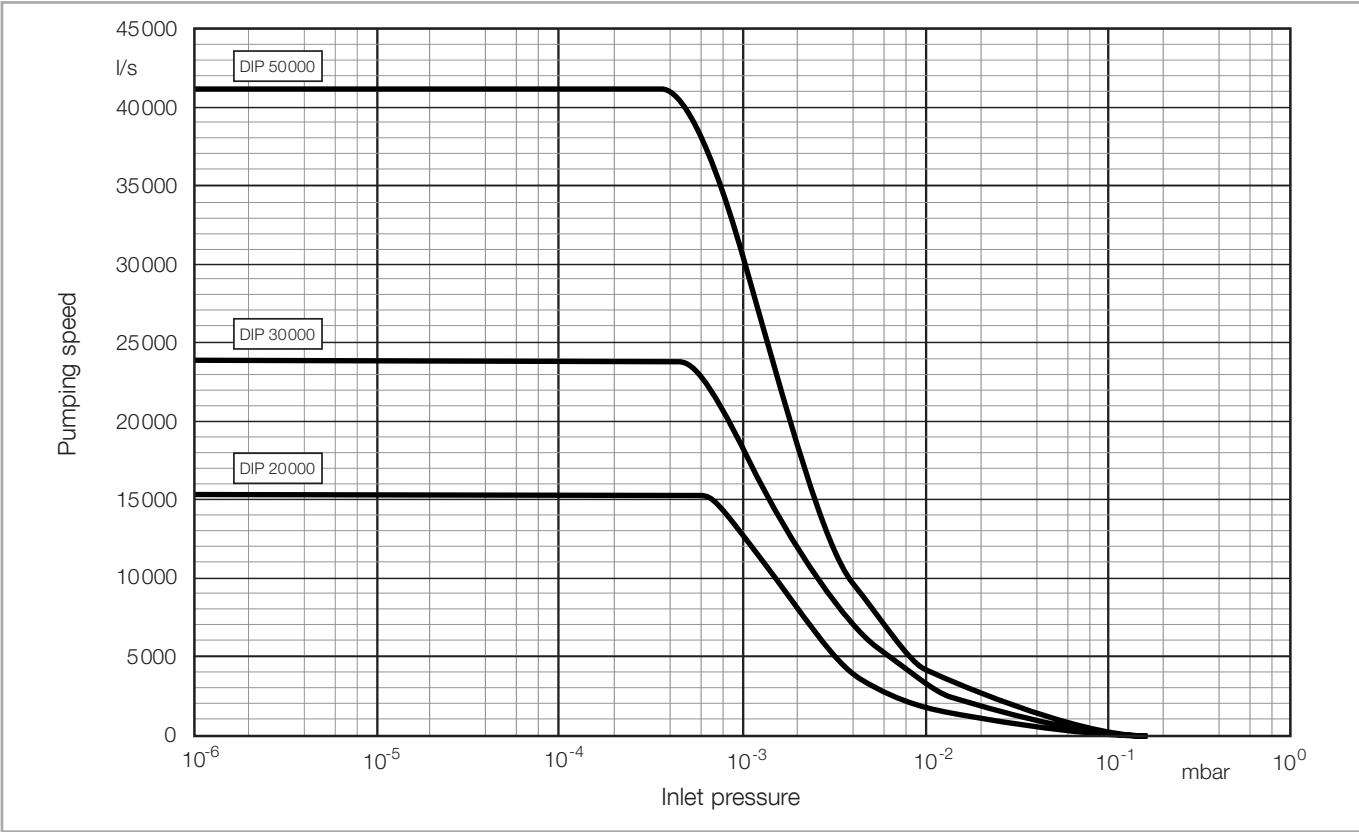

Fig. 2 Pumping speed overview for air

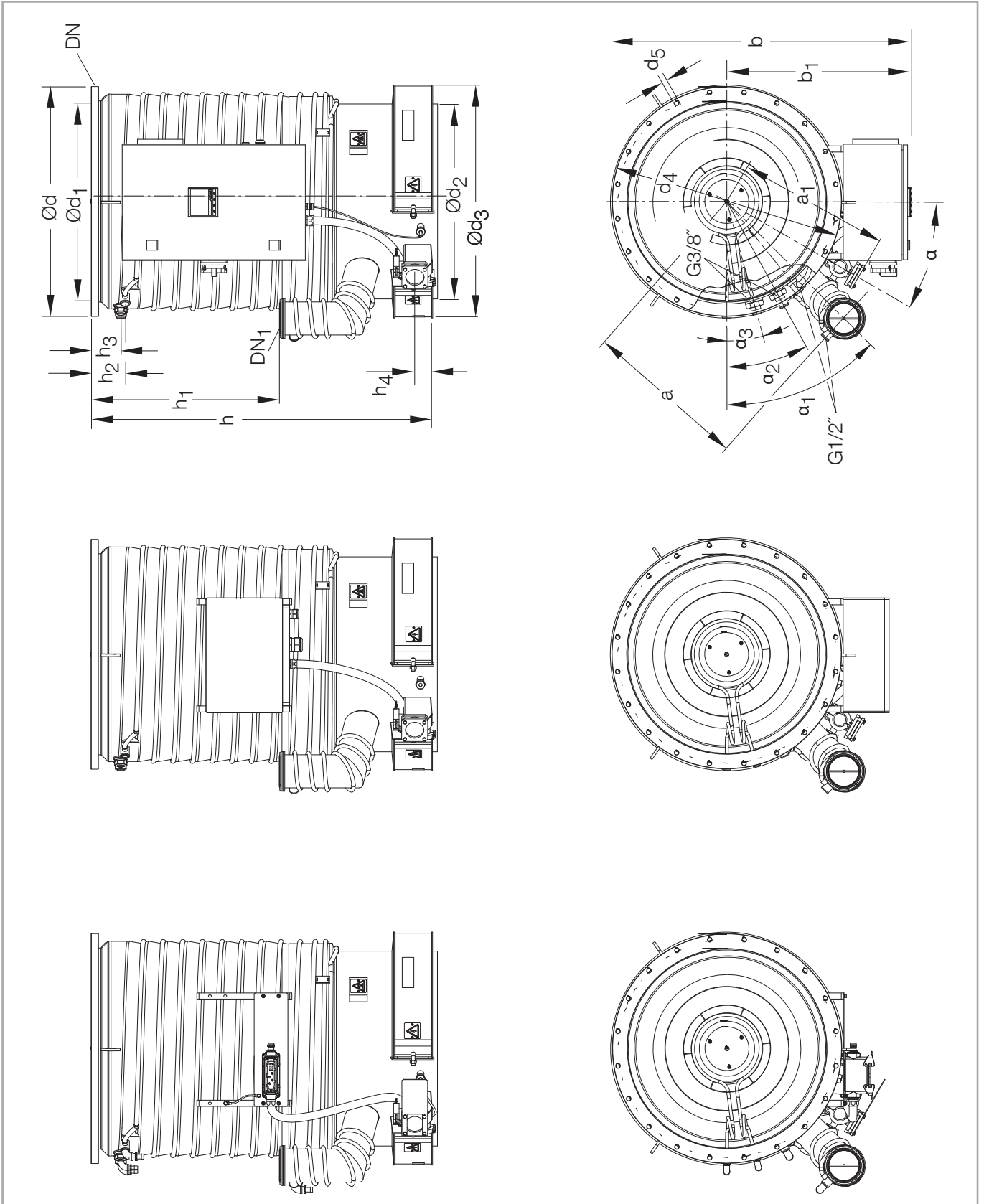

Fig. 3 Dimensional drawings for DIP versions (with plug, with junction box, with EEC)

Description

DIP	20 000	30 000	50 000
DN	630 ISO-F	800 ISO-F	1000 ISO-F
DN ₁	100 ISO-K	160 ISO-K	160 ISO-K
d	750	920	1120
d ₁	651	800	1000
d ₂	636	716	916
d ₃	760	840	1040
d ₄	720	890	1090
d ₅	14	14	14
Number (d _g)	20	24	32
a	540	600	800
a ₁	496	536	636
b	920	1090	1290
b ₁	540	630	730
h	1130	1450	1880
h ₁	620	870	1275
h ₂	110	116	116
h ₃	97	102	102
alpha	30°	20°	25°
alpha ₁	45°	45°	45°
alpha ₂	30°	30°	25°
alpha ₃	15°	15°	15°
with plug			
b	861	1060	1247
b ₁	481	600	863
with EEC			
b	980	1150	1350
b ₁	600	690	790

1.4 Ordering Information

Ordering Info	DIP 20000	DIP 30000	DIP 50000
DIP (off-shelf) 400V / 50/60Hz / 3ph PN	222 30	222 35	222 40
DIP (off-shelf) 460V / 50/60Hz / 3ph PN	500 882	500 665	500 728
DIP w/ Energy Efficiency Control 400V / 50/60Hz / 3ph PN	22230V001	22235V001	22240V001
DIP w/ Energy Efficiency Control 460V / 50/60Hz / 3ph PN	22230V002	22235V002	22240V002
DIP w/ plug 400V / 50/60Hz / 3ph PN custom DIP versions on request	22230V006	22235V006	22240V006
Astrotorus vapor baffle	227 70	227 75	227 80
built-in baffle	22770V001	22775V001	22780V001
extended vapor baffle	500001232	6526861	6524577
Gas cooler	85418V000	85419V000	85419V000
Water-flow monitor		500006623	
“Anti-Seize”		E06025124	
Thermostatic safety switch		122 84	
Contact thermometer		218 81	
Thermoelement Pt 100 sensor		E06025124	
Pump fluid (see below)			

Description

1.5 Overview of Pump Fluids

NOTICE



Prior to using PFPE (Leybonol LVO 400 or LVO 410) consult with Leybold.

Technical data		Mineral oils/ LEYBONOL	Silicone oils
		LVO 500	LVO 521
Vapor pressure at 20 °C	mbar	$1 \cdot 10^{-8}$	$3.0 \cdot 10^{-10}$
Relative molecular mass	$\text{g} \cdot \text{mol}^{-1}$	510	546
Flash point (DIN ISO 2592)	°C	> 240	> 240
Viscosity at 25 °C	$\text{mm}^2 \cdot \text{s}^{-1}$	115	175 / 8 ¹⁾
Density at 20 °C	$\text{g} \cdot \text{cm}^{-3}$	0.862	1.097 ²⁾

¹⁾ at 30 / 100 °C

²⁾ at 25 °C

Ordering info		LVO 500	LVO 521
Pump fluid / oils	1 l	L 500 01	L 521 01
	5 l	L 500 05	L 521 05
	20 l	L 500 20	–

LEYBONOL Oils	Characteristics	DIP all sizes
LVO 400	PFPE synthetic oil, chemically inert, high thermal stability	possible
LVO 410	PFPE synthetic oil, chemically inert, high thermal stability	possible
LVO 500	white mineral oil, free of additives, good thermal stability	default
LVO 521	silicone oil, very high thermal stability, high resistance against oxidation	possible

2 Transport and Storing

Loss of stability during transport

Uncontrolled movement through incorrect fastening/raising/lifting of the pump system.

Use all crane eyes when lifting the pump body. Pay attention to the centre of gravity!

Transportation flanges (blank flanges) and claws may be used only for transportation purposes; they are not suitable for the assembly of the pumps in systems.

Uncontrolled movement through inertia of mobile pump systems (wheels / mobile frame)

Mount and move mobile pumps with roles only on flat, solid, horizontal surfaces.

Pay attention to appropriate slow speed when moving the pump.

The DIP pump is shipped upright on a pallet and packed in a wooden crate. Proceed as follows to unpack the unit; see Figure 4.

- Remove the shipping papers from the pocket (4/5).
- Position the pallet on a flat and level surface.
- Remove the tightening straps (4/2).
- Loosen the 4 bolts at the upper part of the wooden crate and turn the brackets (4/4) up. Then tighten the bolts once more. Affix the lifting gear at the brackets and lift the wooden crate up and away.
- Remove the plastic wrapper.
- The DIP pump is now freely accessible on the pallet on the floor.
- Remove the bag containing the desiccant.

The DIP pump may be moved only when it is standing upright on a pallet or suspended from the lifting eyes. After unpacking the unit, examine the shipment for completeness and any possible shipping damage (see Section 1.2, "Standard equipment").

The pumps are shipped evacuated (corrosion protection). Do not air the pumps until immediately before installation.

To vent the pump, pull the closure plug out of the hose nozzle in the forevacuum shipping flange (5/5).

The ambient temperature range of -20 to +70 °C must not be exceeded during transport and storing.

DANGER



Transport and Storing

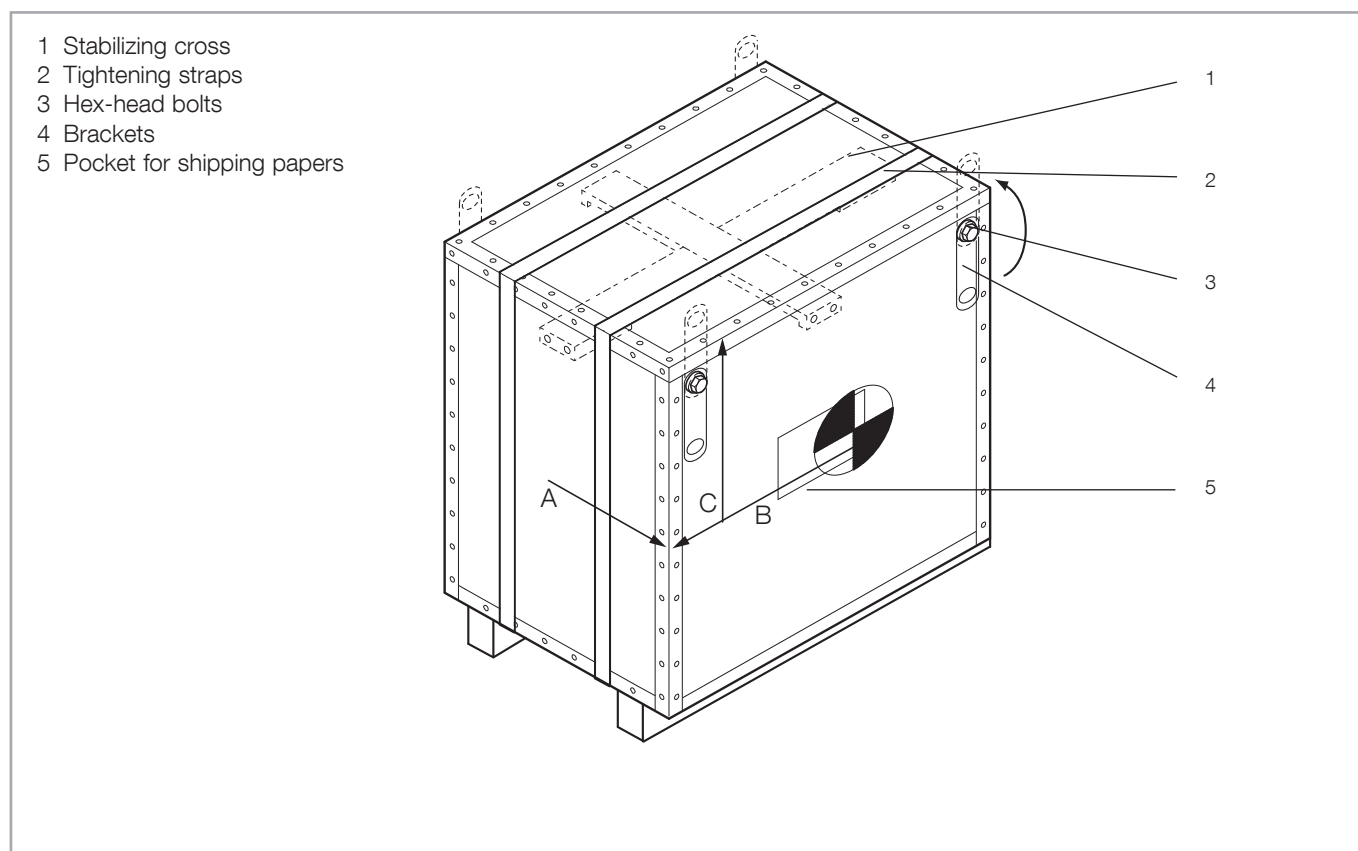

Fig. 4 DIP pump in the shipping case

Storing

Maintain the pump in stock so that it is dry and not exposed to frost. The cooling coils need to be blown out and must be dry.

Keep the pump in stock standing upright.

Pumps having a filling of PFPE should be sealed off in a gas-tight manner and vented with nitrogen.

Center of gravity overview

	Case size LxWxH (mm)	Gross / net weight (kg)	COG A, B, C (mm)
DIP 20 000	1120 x 1030 x 1550	345 / 240	460, 460, 750
DIP 30 000	1250 x 1150 x 1850	495 / 390	530, 530, 1000
DIP 50 000	1400 x 1350 x 2250	590 / 480	630, 630, 1350

3 Installation

3.1 Conforming Utilisation

The pumps in the DIP series are high-vacuum pumps. They are always operated in conjunction with forevacuum pumps.

They are employed in high-vacuum technology to evacuate vacuum chambers.

In the case of inflammable and explosive gases, please discuss with Leybold beforehand.

The pumps are suitable for the pumping of gas mixtures containing oxygen concentrations of < 21%.

They are suitable for conveying of oxidative substances in combination with the suitable pump fluid.

Fore-vacuum pressure range of use < $5 \cdot 10^{-1}$ mbar.

3.1.1 Non-conforming Utilisation

The DIP pumps are not suitable for pumping of:

- Oxygen in concentrations of > 21%
- Radioactive substances
- Ignitable gas mixtures
- Pyrophoric gases
- Liquids
- Toxic gases according to GHS category I and II

The transport of the following gasses is only permitted after consulting Leybold:

- Corrosive gases
- Toxic gases according to GHS category III and IV
- Oxidative gases

3.1.2 Risk of Damaging the Pump

- 1 When deviating too far from the vertical installation orientation ($>1^\circ$), there is the risk that the heating cartridges will run dry thereby damaging the pump.
- 2 Switching the heating cartridge on and off repeatedly will result in its premature failure.
- 3 Missing or wrong connections for the safety thermostats can cause the pump to overheat or destroy the heating cartridges.
- 4 Connect the pump in such a way that it will not start again spontaneously once a monitoring component (thermostat, overheating protection switch, coolant flow monitor) has been tripped.
- 5 All the pump's interior surfaces must be carefully cleaned before filling the pump with a different oil compound (e.g. from mineral oil LVO 500 to silicone oil LVO 521).

NOTICE



Installation

- 6 The DIP may be vented only after the pump fluid temperature has fallen to below 100 °C.
Ventilation should preferably be from the high-vacuum side, into the cool pump.
- 7 The pressure of the steam cleaner may
 - only amount to 4 bar when cleaning the heat conducting panels of the heater inserts (risk of breaking the copper lamellae)
 - only amount to 10 bar for the remainder of the pump.
- 8 The nozzle assembly must only be dismantled by qualified and trained personnel. Please contact our Service Centre.
- 9 Do not use any chlorine based decalcifier since this will damage the cooling coils due to crevice corrosion.
- 10 Only install heater cartridges which are dry. During longer storage periods the heater cartridges attract humidity due to the hygroscopic nature of the insulation materials used, In this case the cartridges may be dried in a drying oven for 8 hours at 180 °C. After longer system downtimes slowly startup the diffusion pump by a cyclic and gradual heating up.
In order to avoid any danger of electrical problems, **do not** apply the never-seize spray to a 20 mm length of the cylindrical section of the cartridge at the connection end.

3.2 Ambient Conditions

Ambient conditions for the pump must not exceed or underrun the following values:

- Temperature: 0 – 55 °C
- Humidity: 85 %
- Altitude of installation site < 1500 m (NHN)

With using the optional Energy Efficiency Control the aforementioned values change accordingly to:

- Temperature: 5 – 40 °C
- max. altitude 1000 m (NHN)

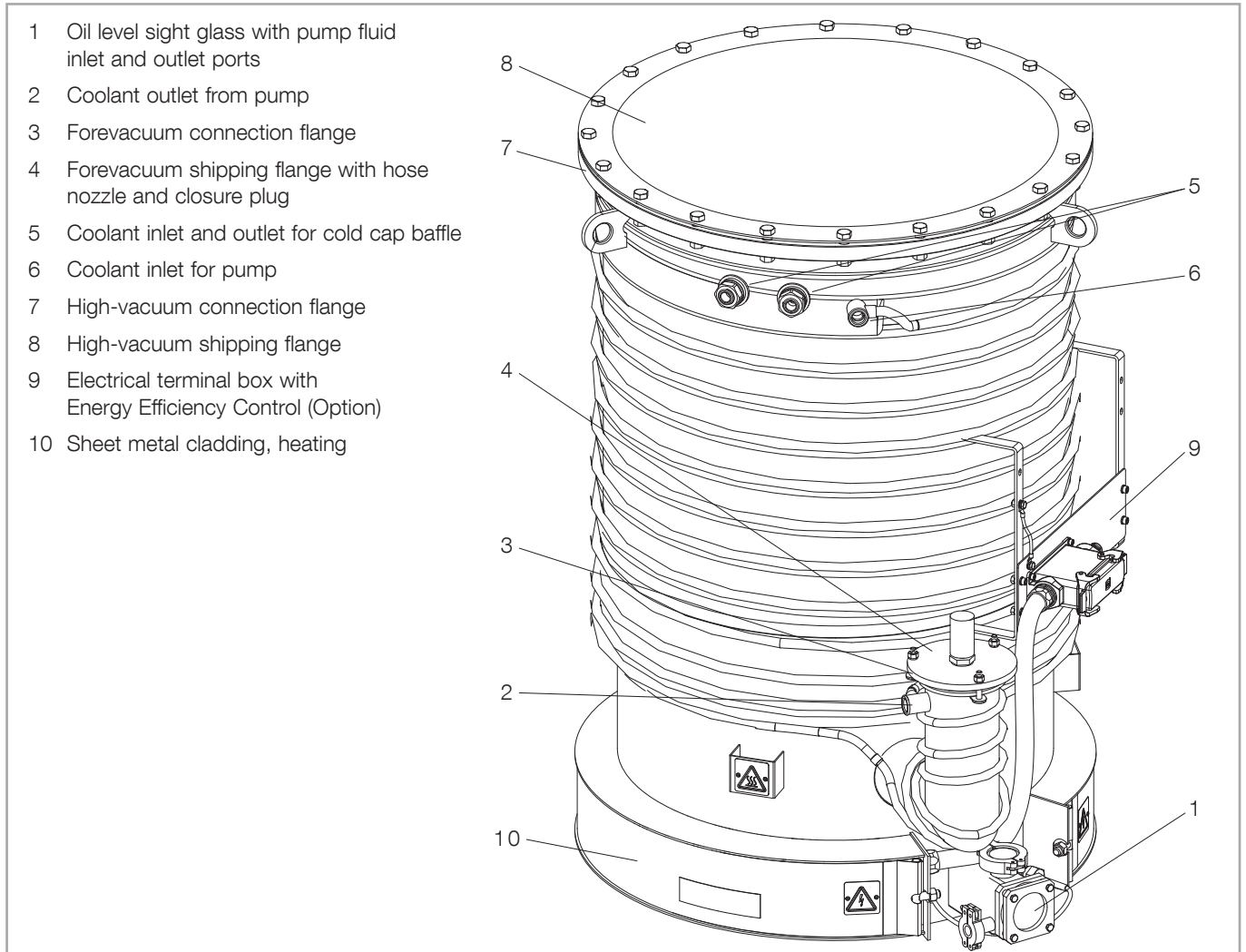

Fig. 5 Connection elements

3.3 High-vacuum Connection

The DIP pumps are shipped evacuated. Do not air the pump until immediately before it is installed; to do so, open the closure plug at the forevacuum shipping flange.

Remove the high-vacuum shipping flange (5/8).

The pump must be standing flat and level or vertically suspended from the high-vacuum connection flange when installed in the system.

When deviating too far from the vertical installation orientation ($>1^\circ$), there is the risk that the heating cartridges will run dry thereby damaging the pump.

NOTICE



Installation

We recommend maintaining a clearance of **500 mm** on top and around the pump to other system components as well as a ground clearance of 100 – 150 mm. This facilitates maintenance work on the pump's heating unit with the pump left in place in the system.

Make sure that the control side is easily accessible and does not expose the operator to a potentially dangerous situation.

Check to ensure that the centering ring (15/16), together with the O-ring (15/17) and the outer ring (15/18) are seated securely in the high-vacuum flange (15/15).

DIP 20 000, 30 000, 50 000: Use M 12x60 (8.8) bolts and matching nuts to join the ISO-F flange; cf. the dimensional drawing for the specific number required.

WARNING

The shipping flange (blank flange) and claws may be used only for shipping purposes; they are not suitable for mounting the pumps in systems.

Where maintaining uniform pressure is of special importance, and particularly when working in pressure ranges of less than 10^{-6} mbar, we recommend using at all flange connections at the high-vacuum side the “ultra” sealing plate instead of the centering ring with an O-ring.

Necessary to achieve maximum conductance at the high-vacuum line is that it exhibit the largest possible nominal diameter and be as short as possible. The DIP pump must be suspended vertically.

3.4 Forevacuum Connection

A forevacuum system is required for operating the DIP pumps. We recommend our TRIVAC, SOGEVAC, or DRYVAC pumps in conjunction with roots booster pumps.

Remove the forevacuum shipping flange (5/5).

Connect the forevacuum line with the centering ring, O-ring and outer ring at the forevacuum port (5/3).

The centering ring also serves at the same time as the attachment point for the water-cooled baffle (15/3) in the forevacuum port.

WARNING

The shipping flange (blank flange) and claws may be used only for shipping purposes; they are not suitable for mounting the pumps in systems.

The diameter of the forevacuum line should be at least as large as the forevacuum flange nominal diameter; the line should be as short as possible in order to achieve the maximum conductance value.

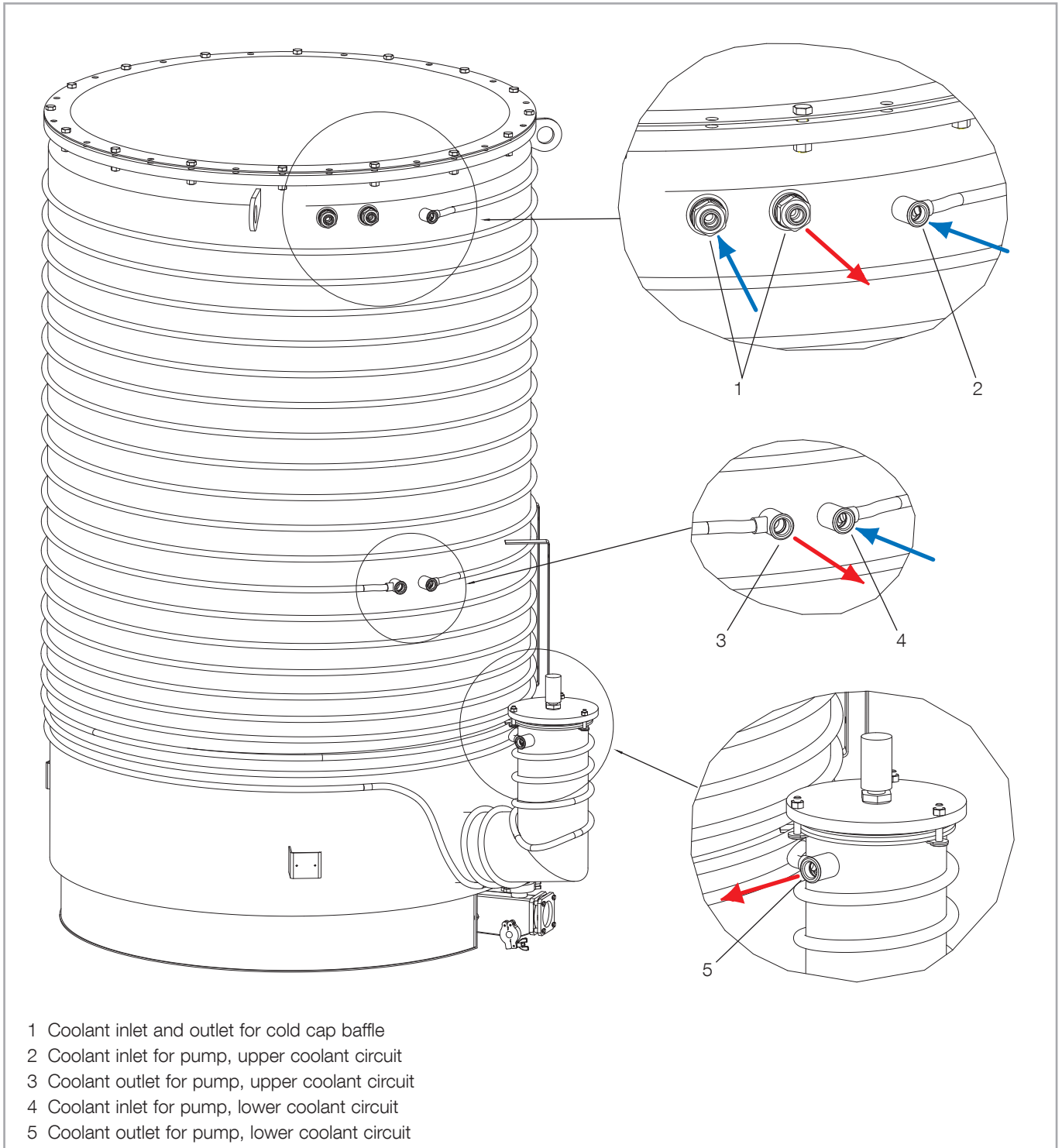

Fig. 6 Coolant connections at the DIP 30 000 and 50 000

CAUTION

3.5 Coolant Connections

Ejection of parts through implosion of a part of the pump or the pump system

If the boiler overheats due to too little or no oil or too little cooling water flow, the boiler can implode.

The water cooling system may not be interrupted in the case of a malfunction.

Observe the installation regulations.

It is necessary to connect the coolant system prior to operating the DIP pump.

Coolant pressure should not exceed 6 bar.

We recommend coolant feed temperatures of between 15 °C and 20 °C.

Coolant return temperature should normally not exceed 50 °C at the outlet. It is important to pay attention to this in particular where the DIP pump is connected to a closed coolant circuit. Depending on the application, the discharge temperature can also be set higher. However, it must be ensured that the corresponding coolant lines are suitable for these temperatures.

We recommend using conditioned water to avoid the formation of scale deposits (which would impair cooling performance).

The DIP 20 000 has two coolant circuits which can be connected in series.

- 1. Cold cap baffle: coolant inlet and outlet: (5/6)
- 2. Pump: coolant inlet: (5/7)
Coolant outlet: (5/2)

Important is that the coolant flow first into the cold cap baffle.

The DIP 30 000 and 50 000 have three coolant circuits:

- 1. Cold cap baffle: coolant inlet and outlet: (6/1)
- 2. Pump: upper coolant circuit: (6/2) and (6/3)
- 3. Pump: lower coolant circuit: (6/4) and (6/5)

The pump's upper and lower coolant circuits may be joined one with the other: connect the outlet (6/3) to the inlet (6/4). In this operating mode the discharge temperature at the outlet (6/5) should not exceed 50 °C. If the coolant return temperature should rise above 50 °C, then we recommend operating the pump with separate coolant circuits.

3.5.1 Water Quality

In order to ensure long trouble-free operation the cooling water must not contain any oils, greases and suspended solids. Moreover, we recommend compliance with the following limit values:

Appearance	Clear, free of oils and greases
Suspended matter	< 250 mg/l
Particle size	< 150 µm
Electrical conductivity	< 700 µS/cm
pH value	7.0 to 9.0
Total hardness (total alkaline earths)	< 8 °dH
Aggressive carbon dioxide	None, not detectable
Chloride	< 100 mg/l
Sulfate	< 150 mg/l
Nitrate	≤ 50 mg/l
Iron	< 0.2 mg/l
Manganese	< 0.1 mg/l
Ammonium	< 1.0 mg/l
Free chlorine	< 0.2 mg/l

8 °dH (degrees German hardness) = 1.4 mmol/l
= 10 °e (degrees English hardness)
= 14 °f (degrees French hardness)

If there is the danger of frost, you may use a water glycol mixture of up to 30 %.

DS water can be used for cooling the pump, if the pH value corresponds to the range indicated above.

3.6 Electrical Connections

DANGER



Electric shock through direct or indirect contact of live parts

Electric shock by touching active electrical components. Voltage spreading through incorrect electrical connection.

The electrical connection may be carried out only by a trained person. Observe the national regulations in the country of the user, e.g. for Europe EN 50110-1.

A protective earth check between the PE connection and every touchable part that requires a protective connection, must be carried out before initial operation. For the test current use 10A DC or AC (RMS), while 0.1 Ohm impedance must not be exceeded.

The temperature sensor (Pt 100 heating cartridge temperature) may take on voltage that is dangerous to touch. The operator must take suitable precautions for protection in case of indirect touching. For example, a temperature transducer with double or reinforced isolation may be used for this purpose.

Connect a second protective earthing conductor.

There are hazardous voltages present on the mains cables (danger to life).

Before carrying out maintenance or service work on the product, take it off the mains supply. After mains power off, wait for 5 minutes!

DANGER



Loss of power supply

The pump fluid is no longer heated in case of failure of the power supply. There is no risk from the DIP. The pump fluid cools down. The risk of the entire system cannot be assessed. In the worst case, the system will be vented rearward and can explode.

The valves must be closed in the event of a power failure.

Air infiltration in an operation-ready, warm diffusion pump are a dangerous condition and must be reliably ruled out.

If electro-pneumatically propelled high- and fore-vacuum valves are used, these must be used shut in the specification “de-energised” and “unpressurised”. Also for these valves, the ventilation of a ready-to-operate, hot diffusion pump must be ruled out through appropriate latch circuits.

The components must be connected correctly and properly. Electrical safety examinations, in particular the insulation and protective grounding conductor examination, must be carried out.

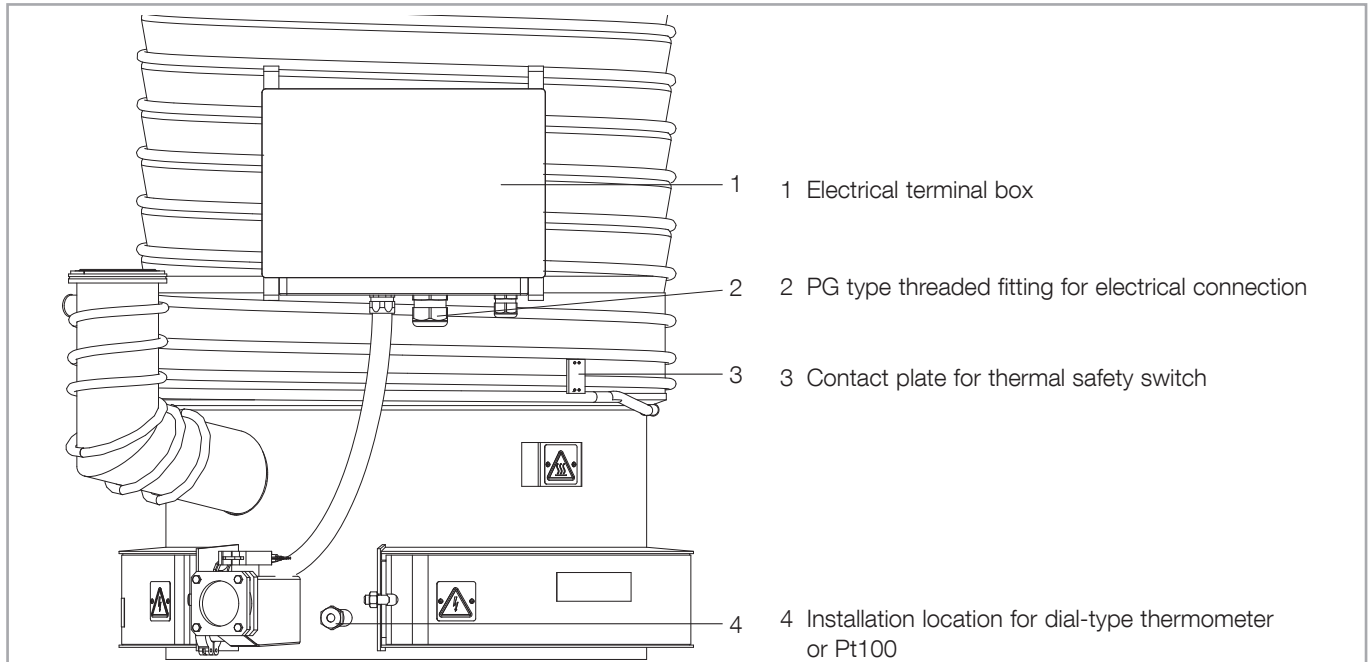

Fig. 7 Electrical connections

High electrical fault currents due to moisture absorption by mineral insulating material of the heating elements

The hygroscopic insulation of the heating element could lead to a burn-out of the heater cartridge. Risk occurs through longer shut-off cycles and humid ambient conditions.

Take note of the installation instructions for the replacement and connection of the heater cartridge.

Check stock before changing/inserting (measured value: 49 to 55 ohms) and degas if necessary.

In case of standstill, check heater cartridge after one year.

CAUTION



3.6.1 Connecting the Heaters

Hazards that may occur through independent restart of a pump after a shutdown due to an error

Connect the pump in such a way that if a monitoring element is triggered (thermostat, thermal protective switch, water flow guard) it **does not** automatically restart after the inadmissible operating condition has ended.

CAUTION



Installation

General installation notes

In all the DIP pumps the heating cartridges are normally wired in a “star” (Y) circuit; this means that they are prepared for connection to a 400 V ($\pm 10\%$), 3-phase, 50/60 Hz, power source.

If the DIP pumps are to be operated on a network in which the current deviates from 400 V, 3-phase, 50/60 Hz (e.g. 230 V ($\pm 10\%$), 3-phase or 460 V ($\pm 10\%$), 3-phase), then the pump will have to be rewired internally. Kindly inquire at the factory for details.

A supply cable sized to correspond to the amount of power drawn or the connected load is to be used when making the connection. The parameters which affect dimensioning include current load, ambient temperature, how the cable is laid and type of cable and conductors. Local codes shall be observed when sizing the connection cable.

Leybold recommends to connect an existing neutral conductor. If the neutral conductor is not connected, there will be no symmetry in case of a heating rod malfunction or failure. This may lead to an untimely destruction of the other heating rods.

NOTICE



The operator must check the impedance of the fault loop, and verify the suitability of the corresponding overcurrent protection device.

After the installation, the required safety tests (e.g., PE conductor test, among others) have to be carried out.

The power consumption figures required to make this selection are given in the following table. The appropriate circuit breakers shall be installed during installation; their specifications are also given in the following table.

An upstream overcurrent protection device must be provided by the system operator, for detecting an insulation error and safely shutting-down the supply automatically.

The supply voltage must correspond to the limits specified.

DIP	Connection voltage $\pm 10\%$	Main fuse	Individual fuses size / number	Cable cross-section
20 000	230 V, 3~	40 A	10 A / 12	4 mm ² installation type C
	400 V, 3~	25 A	6 A / 12	
	460 V, 3~	25 A	10 A / 6	
30 000	230 V, 3~	63 A	10 A / 18	6 mm ² installation type C
	400 V, 3~	40 A	6 A / 18	
	460 V, 3~	32 A	10 A / 9	
50 000	230 V, 3~	100 A	10 A / 24	10 mm ² installation type C
	400 V, 3~	50 A	6 A / 24	
	460 V, 3~	40 A	10 A / 12	

The insulation for the lines from the junction boxes to the fuse boxes shall be resistant to temperatures of up to 200 °C.

Electrical junction box DIP 20000

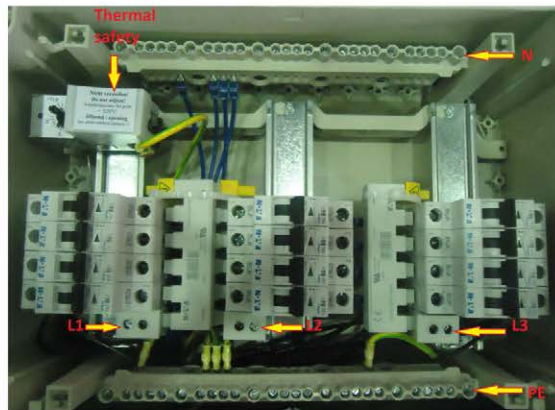
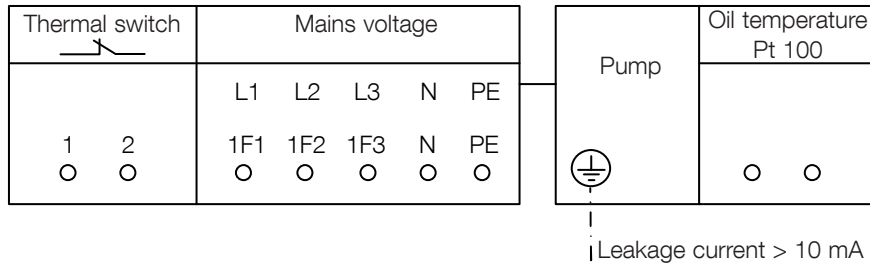

Electrical junction box DIP 30000/50000

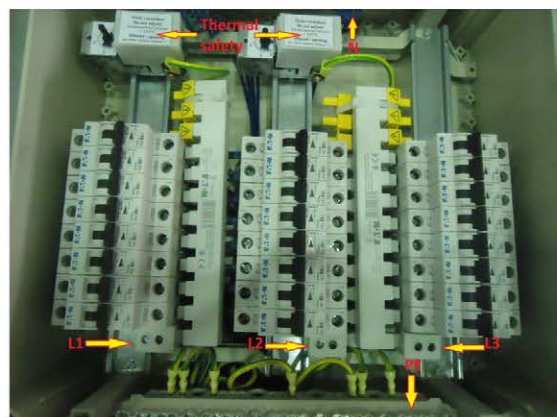
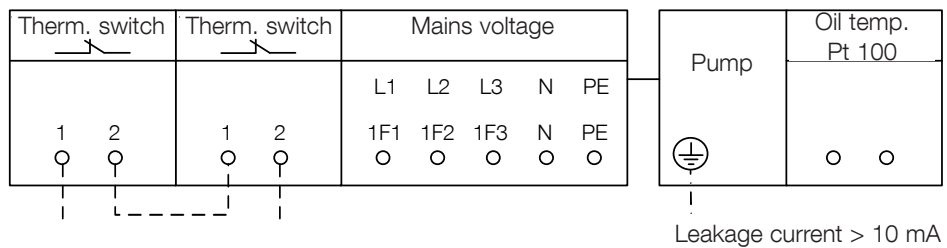
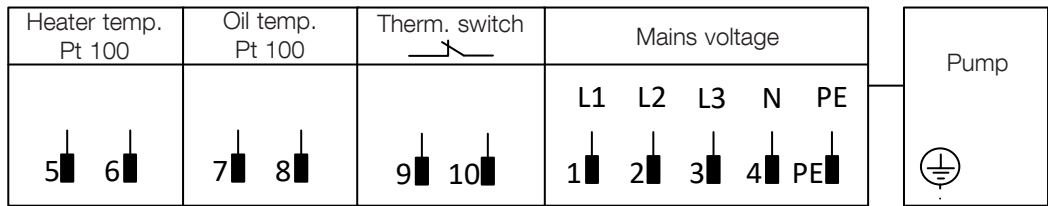

Fig. 7a Electrical junction box

Installation

Harting plug Type K4/8



Leakage current > 10 mA

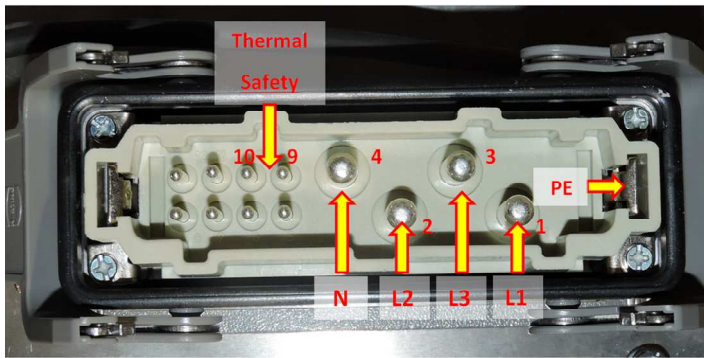

EEC

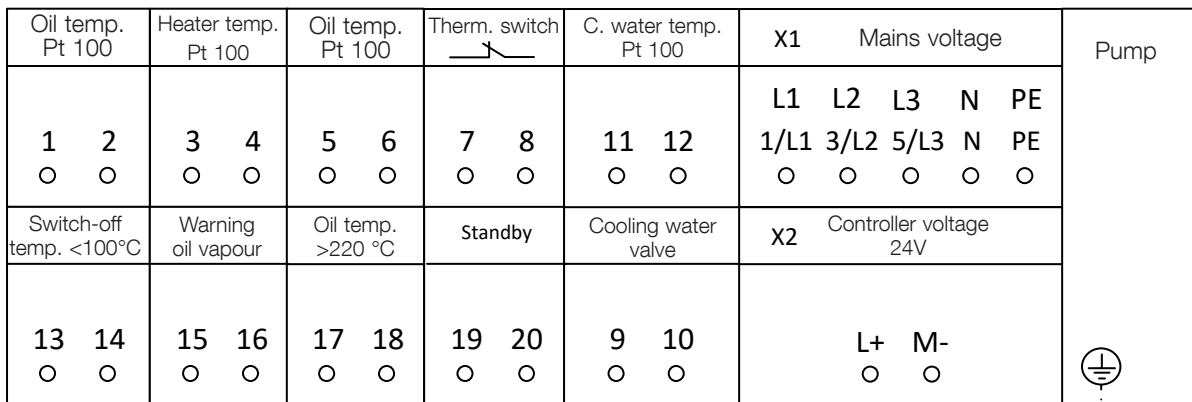

Leakage current > 10 mA

Fig. 7b Versions of electrical connections

DIP w/ plug & EEC (connection cable)

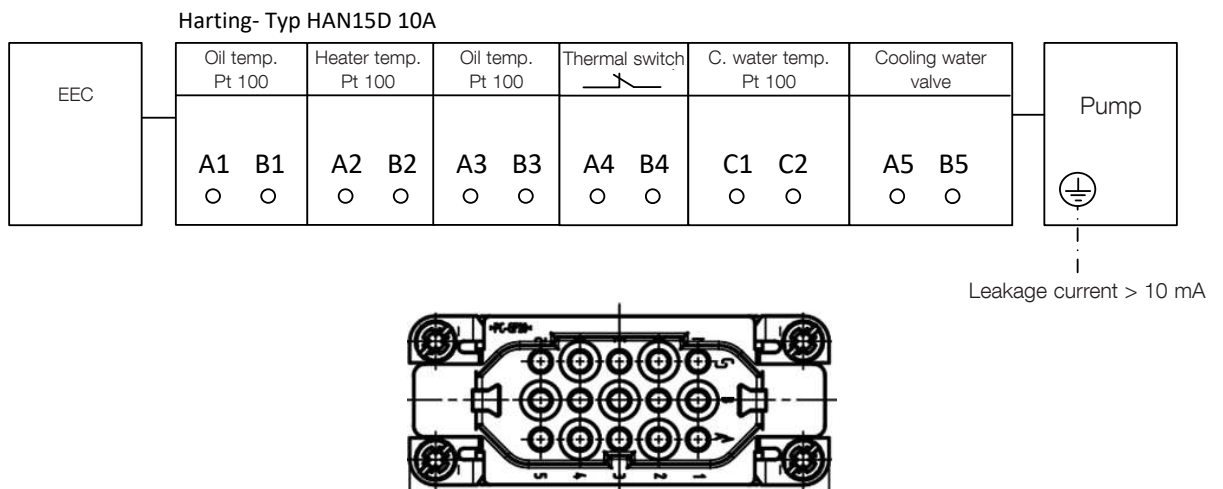
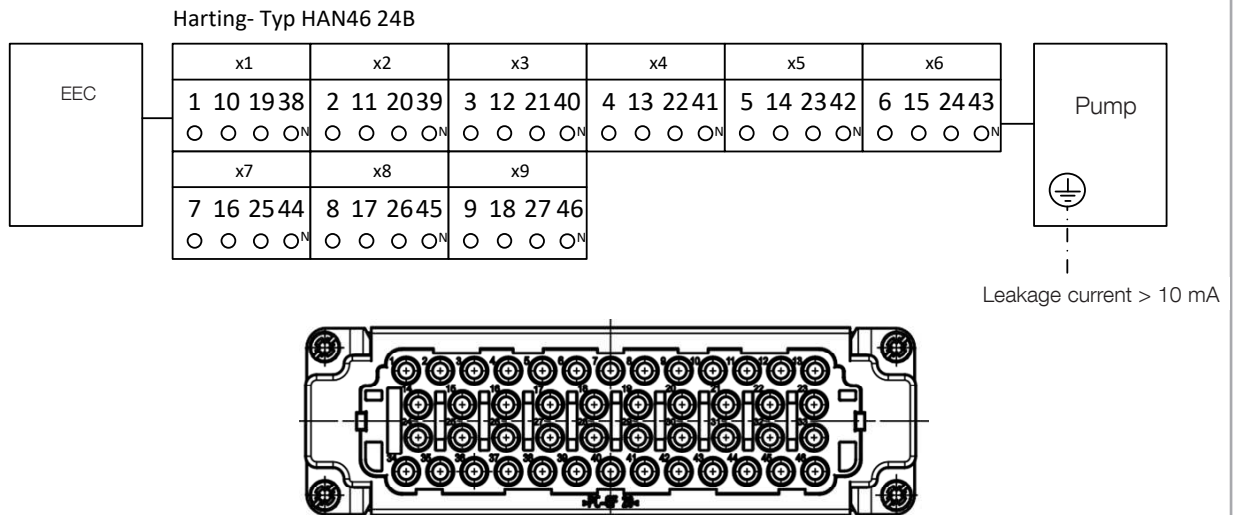

DIP w/ plug & EEC (separate EEC)

X3

Oil temp. Pt 100	Heater temp. Pt 100	Oil temp. Pt 100	Thermal switch	C. water temp. Pt 100	X1 Mains voltage
1 2 ○ ○	3 4 ○ ○	5 6 ○ ○	7 8 ○ ○	11 12 ○ ○	L1 L2 L3 N PE 1/L1 3/L2 5/L3 N PE
Switch-off temp. <100 °C	Warning oil vapour	Oil temp. >220 °C	Standby	Cooling water valve	X2 Controller voltage 24V
13 14 ○ ○	15 16 ○ ○	17 18 ○ ○	19 20 ○ ○	9 10 ○ ○	L+ M- ○ ○

Note: The customer is recommended to integrate Output 7/8 into the system control.

Fig. 7c Versions of electrical connections

Installation

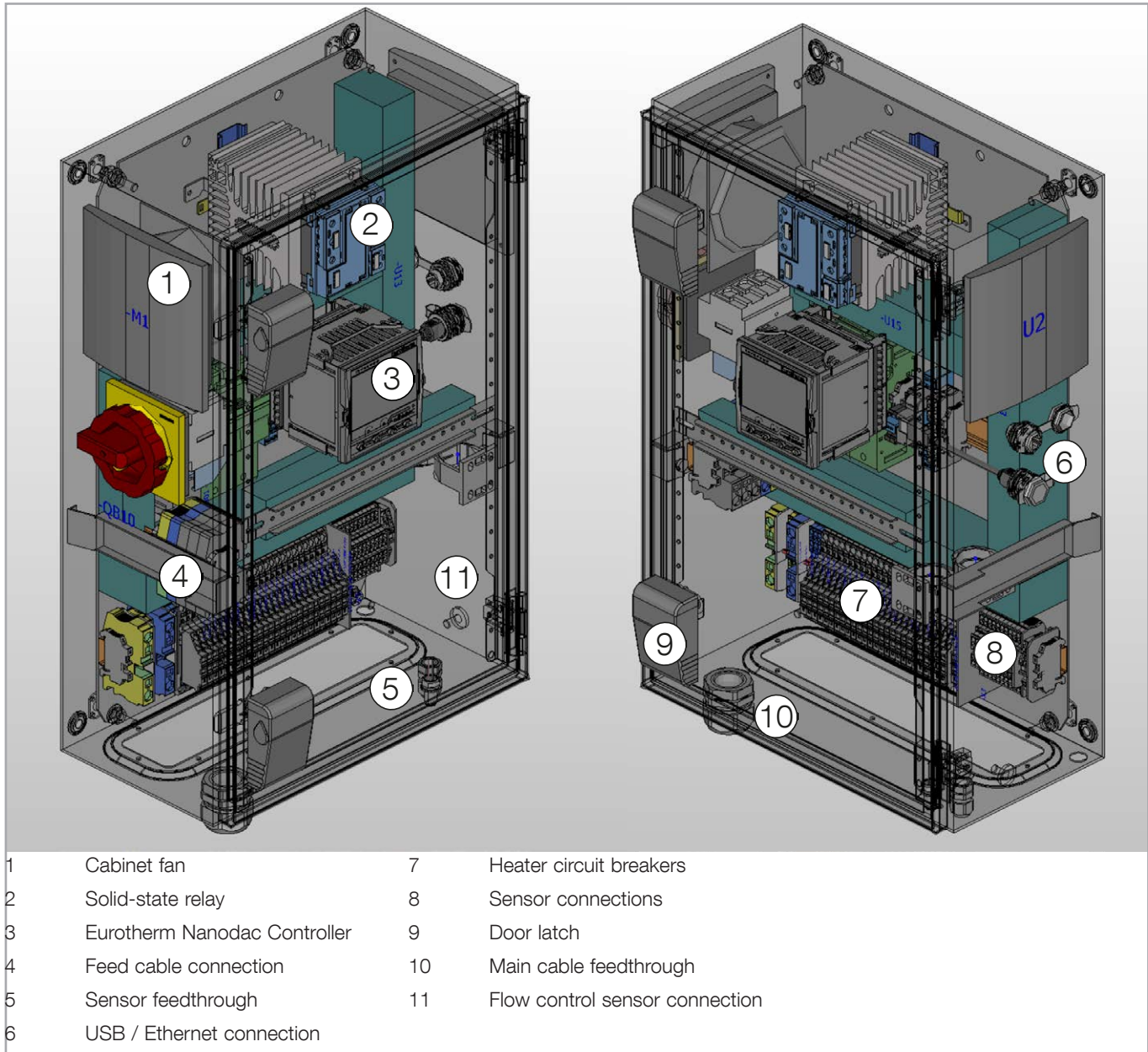

Fig. 7d Control cabinet layout

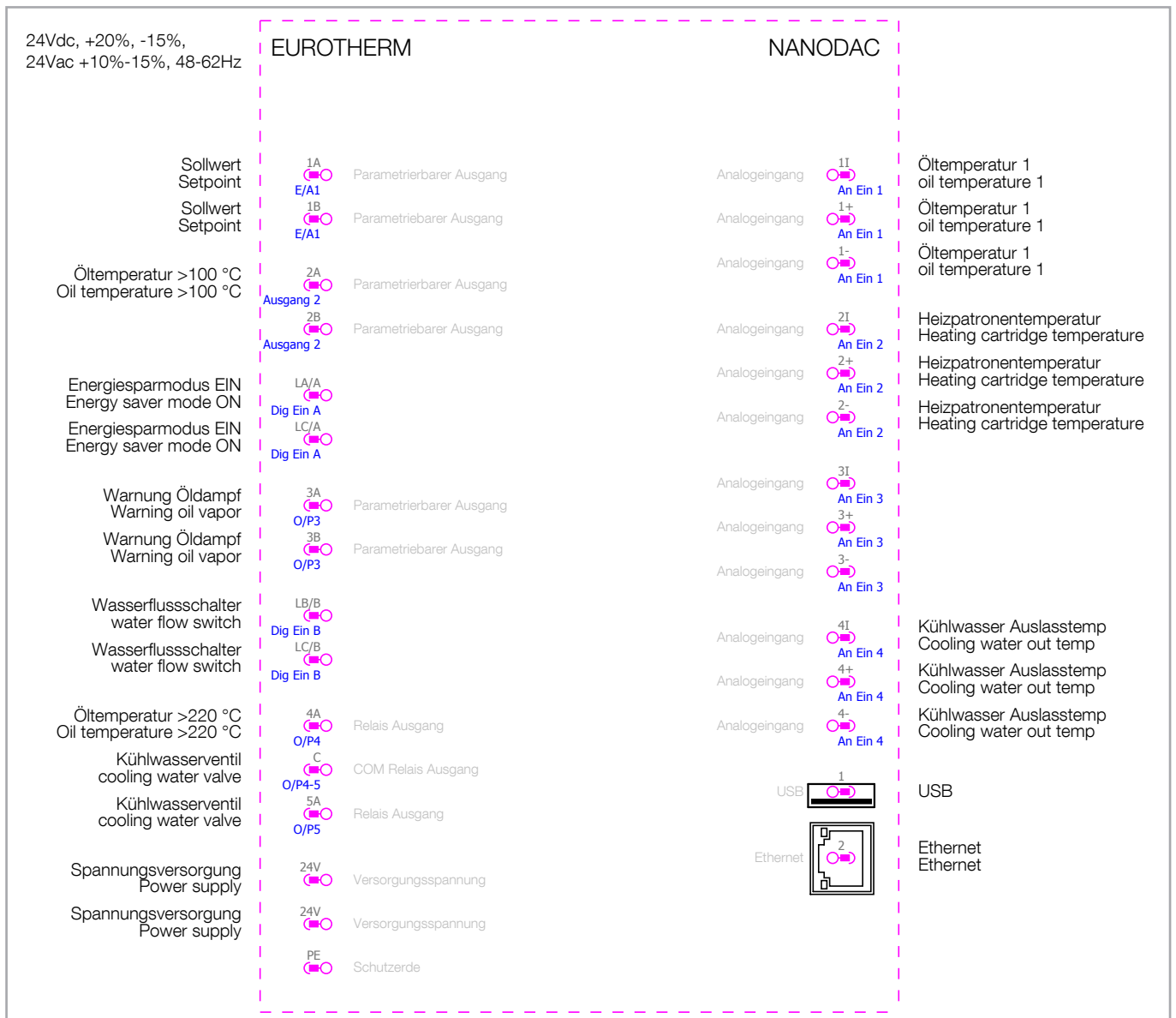

Fig. 7e Terminal assignment

Installation

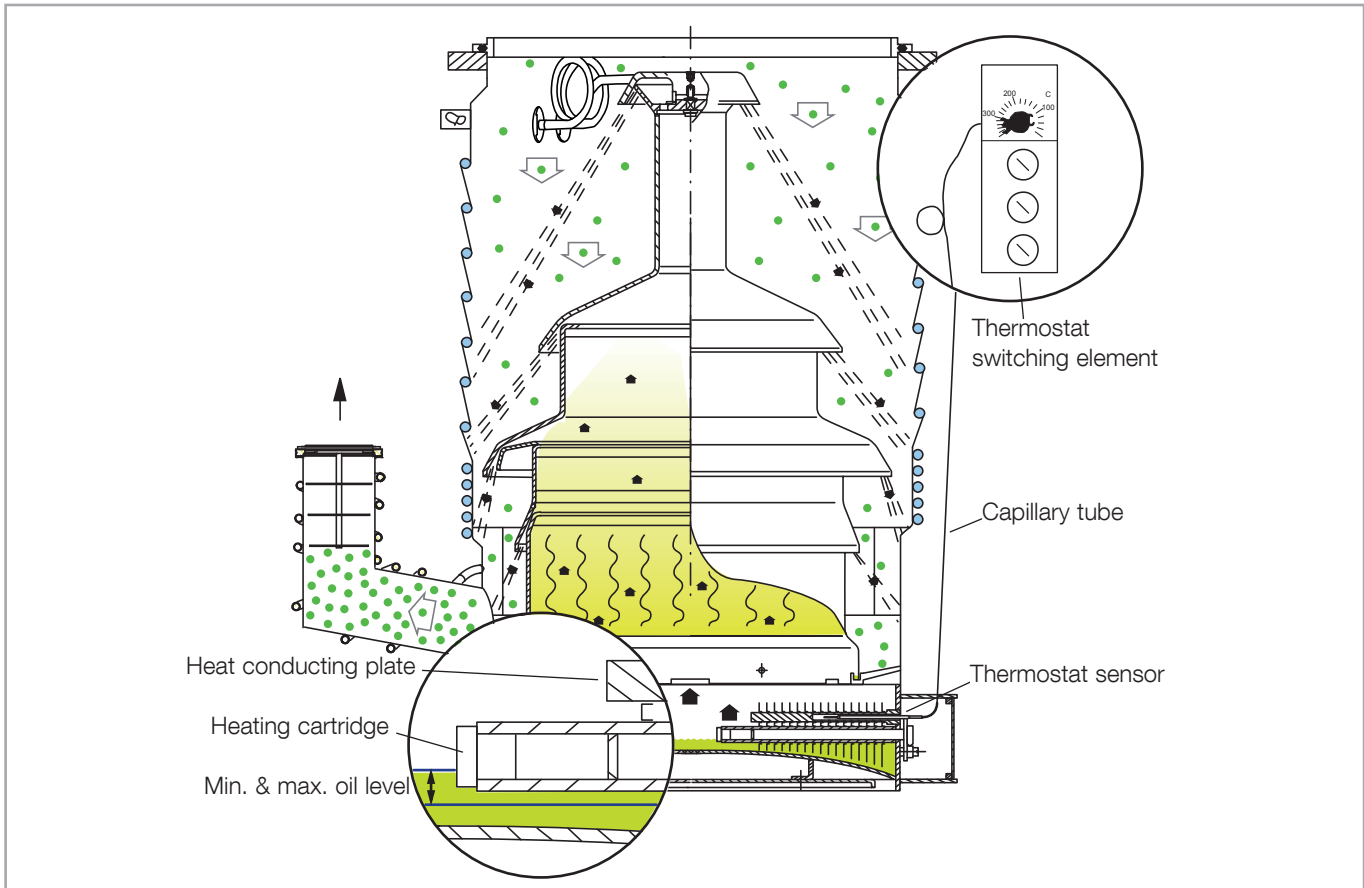

Fig. 8 Thermostat to protect the pump Schutz der Pumpe against overheating

Safety interlock

Operation of the pump heaters at the default-type DIP pump is monitored with a thermostat. Where there is a loss of pump liquid and an unacceptable temperature rise in the vaporization chamber, the heating will be switched off, keeping the cartridges from being overheated.

Thermostat

The thermostat is engineered as a fail-safe temperature monitoring unit which means that if the connection line between the measurement sensor (15/44) and the switching device (15/21) is broken the built-in contact will open, reporting a "fault" as would be the case for unacceptable temperature rise.

DIP	Number of thermostats	Switch-off temp setting
20000	1	330 °C
30000	2	330 °C
50000	2	330 °C

The operator of DIP pump versions without a fuse box must ensure that these systems will be switched off automatically at a temperature of 330 °C.

Switching the heating cartridge on and off repeatedly will result in its premature failure.

The connection for the DIP pump must be routed via a power relay of appropriate capacity (not included as standard equipment). The control circuit for the relay coil is to interface with the switching contact for the thermostat in such a way that the relay will separate the pump from the power supply if unacceptably high temperatures are detected. Use terminals 1 and 2 at the thermostat for this purpose.

Connect the thermostat in such a way that, after the thermostat has disabled the system, the pump cannot start again spontaneously once the system has cooled down again.

Electrical connection at the thermostat

To set up the protective interlock system connect the switching contact for the thermostat with the appropriate power circuit to control the relay coil.

Remove the cover at the electrical junction box. Pass the end of the supply line through the type PG threaded fitting and connect the conductors with the connector contacts at the thermostat (see the schematic for the wiring scheme). Attach the ground conductor in the supply lead to the central grounding point on the backing plate (PE bus). Then connect the supply line with the system control unit in order to ensure that this protective interlock is set up properly.

Missing or wrong connections for the thermostats can cause the pump to overheat or destroy the heating cartridges.

Connect the supply line with the electrical junction box

Pass the end of the supply lead through the type PG threaded fitting.

Attach the ground and neutral conductors at the appropriate PE and N buses inside the fuse box. Connect the neutral conductor only after determining that it can carry a load.

We recommend to provide the pump's connection with a neutral conductor, as with the default delivery a Y wiring is used. If during operation a heater cartridge failure occurs, there will be phase shifting, possibly leading to accelerated failure rates of the other heater cartridges (leakage current).

Then connect the hot conductor(s) (L1, L2 and L3) at the appropriate connection strips for the fuse groups. Tighten down the PG threaded fitting to activate the strain relief feature and then reinstall the cover on the electrical junction box.

Carry out the corresponding electrical safety tests.

NOTICE



NOTICE



NOTICE



3.6.2 Connecting Monitoring Components (optional)

Overheating switch

We recommend installing a thermostatic safety switch (P/N 12284). This switch monitors the coolant temperature and should be located in the immediate vicinity of the coolant pipe (7/3). The contacts are closed at temperatures below 50 °C during normal operations. If the temperature at the sensor rises above 50 °C (in case the coolant circulation should fail, for example), then the contacts will open and shut down the DIP pump heating by way of a relay (to be provided by owner).

Route one phase of the relay in the power supply through the overheating protection switch.

NOTICE

Connect the pump in such a way that it will not start again spontaneously once a monitoring component (thermostat, overheating protection switch, coolant flow monitor) has been tripped and the operating parameters have returned from the unacceptable to the normal status.

Use four cap screws, M 3 x 6 to mount the thermal protection switch (7/2).

Coolant flow monitor

The coolant flow monitor should be installed in the outlet port of the coolant circuit for the series DIP pump.

If coolant circulation fails the flow monitor can, for example, be used to drive a relay which will switch off the pump heating, activate an alarm system or carry out another suitable switching function. The minimum coolant volumes are given in Section 1.3, "Technical Data".

Dial-type thermometer

The dial-type thermometer is inserted at the base of the vaporization chamber, in the opening (7/4) provided for this purpose. Remove the threaded plug to do so.

The dial thermometer has two switching points which can be set independent one of another.

We recommend setting the lower switching point at < 100 °C (pump can be aired) and the upper switching point at > 200 °C (pump is ready for operation).

The contacts for the switching points are connected to leads which terminate outside the thermometer. The signals can be interpreted by an external pump system control unit.

Alternatively also a Pt 100 temperature sensor may be inserted into the bore (7/4).

3.7 Pump Fluid

Hazard of slipping, tripping or falling due to oil leakage from the pump

Depending on the work process, oil may escape from the pump.

Check the pump for any oil that has run out. Take appropriate security measures.

The series DIP pumps are shipped without pump fluid installed.

We recommend using either LEYBONOL LVO 500 or silicone oil (LEYBONOL LVO 521). These compounds are particularly suitable because of their high thermal and chemical stability.

Silicone oils are distinguished by their very low vapor pressure and great resistance to oxidation and decomposition. We recommend using type LEYBONOL LVO 521 silicone oil.

Mineral oils, synthetic oils and PFPE do not mix.

All the pump's interior surfaces must be carefully cleaned before filling the pump with a different oil compound (e.g. from mineral oil to silicone oil).

Install the pump fluid through the pump fluid filler port (12/1).

The quantities of fluid required will be found in Section 1.3, "Technical Data", but may vary slightly due to the pump's design. Always fill in oil up to the max. mark of the oil level eye.

Use a litre gauge to measure the quantity of pump fluid and fill the pump fluid into the pump. When filling the pump for the first time or when filling it after cleaning, we recommend to fill the pump up to its maximum.

After having filled in the pump fluid, wait a few minutes for the pump fluid to spread and then read off the oil level at the oil level sight glass. In order to correctly determine the oil level, read off the filling level at eye level (cf. the figure in Section 5.2, "Checking the Pump Fluid Level").

During operation always ensure that the oil level is at the max. mark of the level indicator.

Operating the pump for long periods with an oil level too low (at or below the min. mark) will lead to problems with replacing the heater cartridges and may damage the pump.

CAUTION



NOTICE



Operation

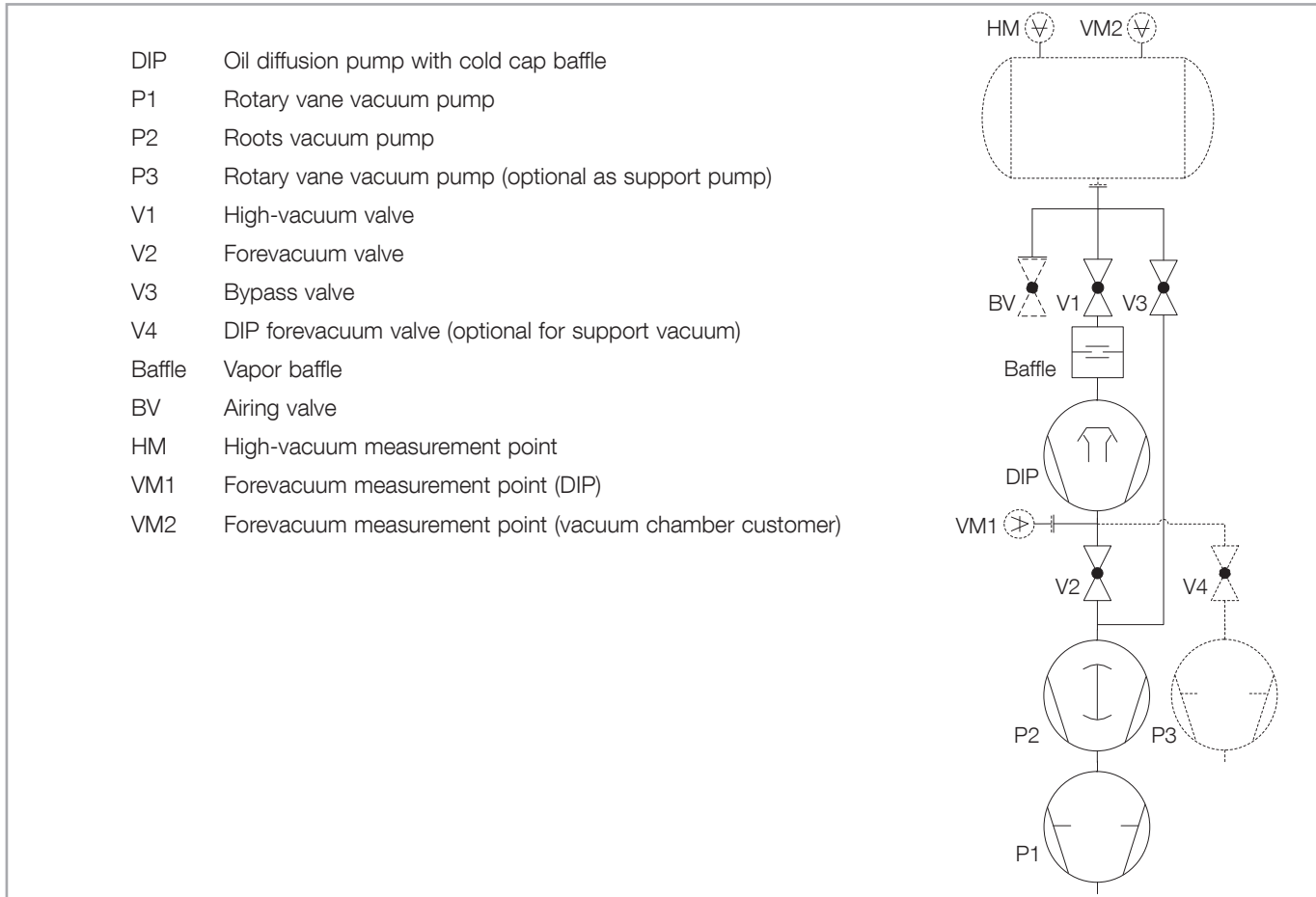

Fig. 9 Schematic for a diffusion-type vacuum pump system

4 Operation

4.1 Media Compatibility

The pump is not suitable for handling oxygen above normal atmospheric concentration.

Kindly contact the manufacturer whenever gases with high hydrogen content are to be pumped (cf. Section 3.1, Conforming Utilization).

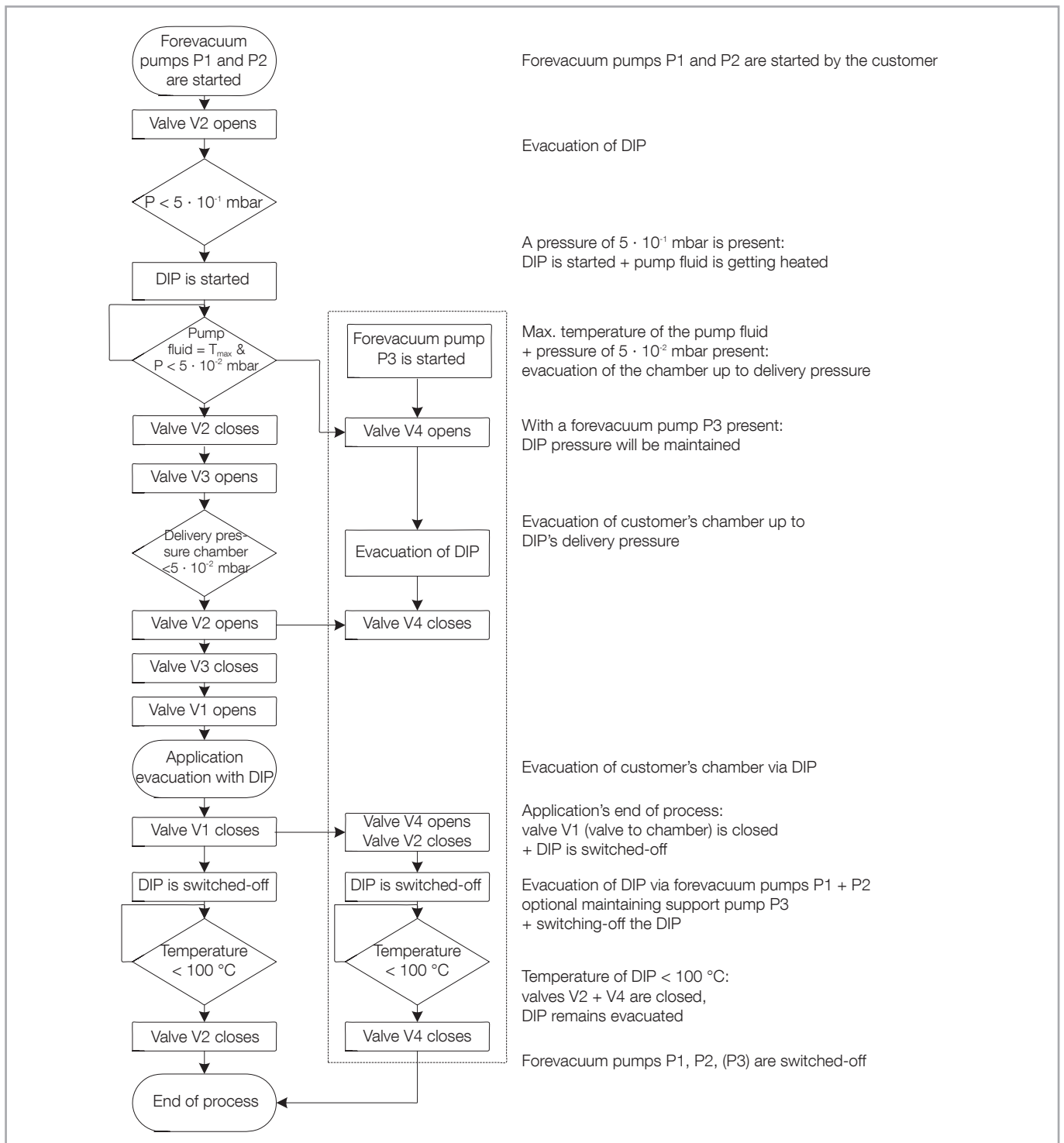

Fig. 9a Schematic for commissioning and operational sequences of a DIP pump system

4.2 Start-up

DANGER



Danger through expulsion of transported toxic gases/vapours. Fire or explosion in case of transport or ejection of flammable gases/vapours, oxidizing agents or pyrophoric gases

Transported process gases can escape out of the exhaust pipe and from leaking areas of the vacuum system.

Transport of toxic gases/vapours, flammable gases/vapours, oxidizing agents or pyrophoric gases is generally excluded.

In its standard version, the pump system is not suitable for operation in ex-zones.

The operator is responsible for the assessment of the hazard potential of the process media and/or mixtures. For this purpose, the operator must perform a risk or hazard assessment. The operator must take appropriate measures to ensure that there is no danger to man and the environment.

Do not use any easily flammable materials near the hot pump area.

Hazards through emission of harmful gases/vapours

During the start-up and the new installation of the heater cartridge, smoke and an unpleasant smell may develop. Therefore, turn on new pumps and pumps after successful servicing of the heater cartridges only in well-ventilated areas. Avoid direct contact with the smoke or gases that can develop during start-up.

The pumping speed attained by diffusion pumps is constant between 10^{-3} mbar and $5 \cdot 10^{-7}$ mbar.

We recommend joining the vacuum chamber direct to the backing pump via a valve V3 and a fore vacuum line. A high-vacuum valve V1 and a forevacuum valve V2 are required for proper functioning of the fore vacuum line.

The vacuum chamber is evacuated down to the transfer pressure via the fore vacuum line. The diffusion pump and pump fluid will operate normally when the high-vacuum valve V1 is opened. Close the forevacuum valve V2 and the high-vacuum valve V1 prior to venting the vacuum chamber; the diffusion pump will remain in a state of operational readiness.

The high-vacuum valve must in its closed state provide a reliable seal. If it is leaky then large quantities of gas will be pumped through the DIP. This will then result in premature ageing of the oil and a significantly increased oil loss.

Ensure to open the high-vacuum valve slowly to reduce flow disturbances within the pump as well as oil losses.

Check the heater cartridges after longer periods of system downtimes (after one year at the latest). This is specially true for pumps in stock.

4.3 Operation

Ejection of parts through bursting of the vacuum system due to excessive pressure, caused by malfunction at the gas inlet into the vacuum system

When venting the DIP pump at > 100 °C danger of explosion!

The pump must be securely locked during operation.

The DIP pump may be vented only if the pump fluid temperature is < 100 °C.

Any rearward venting must be ruled out. The cooled pump should be vented from the high vacuum side.

Turn off the cooling water supply only once the DIP pump has cooled down to < 100 °C.

DIP pump operation with closed high vacuum and fore-vacuum side and simultaneously switched off cooling water supply is a dangerous condition and must be reliably ruled out (e.g. by locking circuit).

Forevacuum line

High-vacuum valve

NOTICE



DANGER



Operation

CAUTION**Getting dragged into the vacuum system**

Do not operate the pump system with opened intake and outlet port.

During installation the system, first connect the system mechanically via the inlets and outlets and only then make the electrical connections.

Ejection of parts through implosion of a part of the pump or the pump system

If the boiler overheats due to too little or no oil or too little cooling water flow, the boiler can implode.

The water cooling system may not be interrupted in the case of a malfunction.

Observe the installation regulations.

CAUTION**Burns from touching hot surfaces**

Burning of fingers, hands, arms on hot surfaces up to +140°C. Hazard of burns with open covers.

Handle the pump only in ventilated and cooled down condition. Wear suitable protective equipment. Take note of the cooling time after switching off.

All the connections and preparations for operation have been made properly.

Operating the pump is permitted only in the installed condition. During operation pumps must not be opened nor vented.

The operator must conduct process-dependent considerations regarding risks with the general starting and stopping, with the operation, and with automatic restarts after power failures of the system.

Switch on the fore vacuum pump and evacuate the DIP pump down to forevacuum pressure $< 5 \cdot 10^{-2}$ mbar; open the coolant supply valve.

4.3.1 DIP without Energy Efficiency Control (EEC)

Switch on the pump heaters. The DIP pump will begin functioning after a certain period of time.

NOTICE



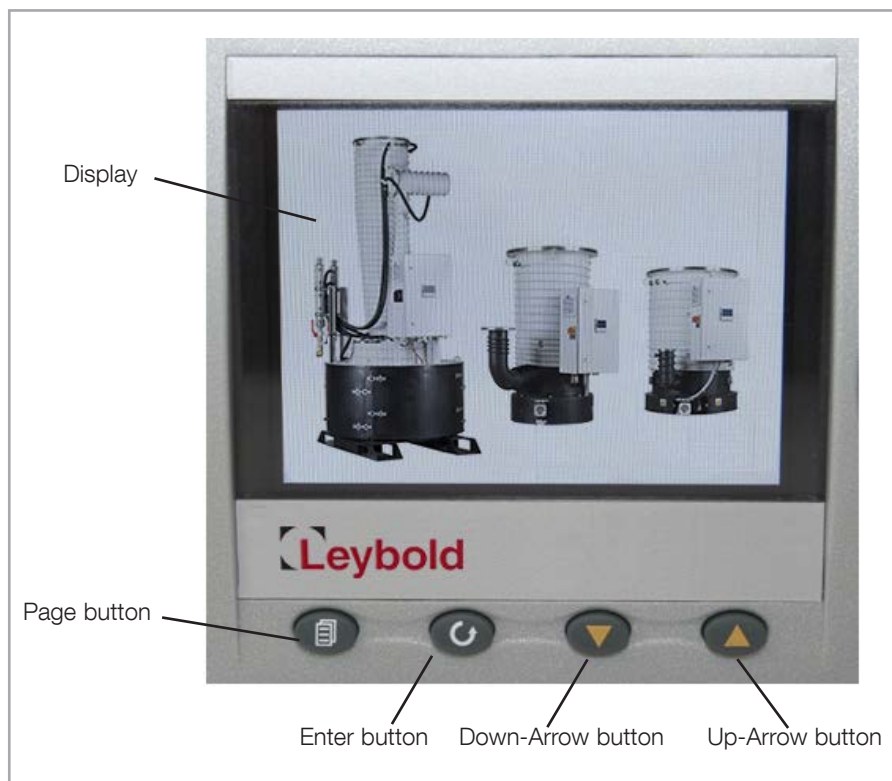

Fig. 10a Screen during boot-up

HINWEIS



4.3.2 DIP with EEC

The EEC is equipped with a buffer battery to prevent data losses in case of a power failure. Ensure to replace this battery every 3 years.

Switch on the pump Energy Efficiency Control.

With the main switch in pos. I, the start screen (depicted above) will be displayed for approx. 20 s during the control unit's boot-up.

The following screen will appear (Fig. 10b).

4.3.2a Adjusting the Oil temperature

The oil temp's set-point is preset to 230 °C. Follow the instructions hereinafter, to change this default value. Observe the notes in Section 4.3.2e.

Pressing the Enter button selects the mode to change the set-point. This will be indicated by the background display colour change to yellow. For changing the value press the Enter button again. Use the Up-/Down-Arrow buttons repeatedly, to change the value of the set-point. To set the new value, press the Enter button again.



Fig. 10b Operational mode's screen

The pump is now controlled by the control unit and sets the new WSP value for the oil temp. During operation the control unit additionally serves as a monitor for the heater temp, the heater power, and the oil temp.

4.3.2b Changing the Control Unit's Display

Pressing the Up-Arrow or Down-Arrow buttons repeatedly toggles between the four different diagrams shown below. Independent of the displayed diagram all the relevant process values for oil temp, heater temp, and heater power are shown.



Fig. 10c Service Monitor



Fig. 10d Bar Diagram



Fig. 10e Graphic Diagram



Fig. 10f Numeric Diagram

4.3.2c Safety System

NOTICE

If the oil reaches a temperature of 330 °C, an error warning is shown on the display, indicated by a yellow flashing. The heaters then will be turned off by the thermal circuit breaker.

A yellow flashing error warning will also be shown, if the heater reaches a temperature of 400 °C.



Fig. 10g Configuration Menu

4.3.2d Changing the Language Settings

To change the displayed language version you have to log-in to the Configuration menu first.

NOTICE

The USB interface is on the control unit's rear side (inside the switching cabinet).

Changes of parameters and values in configuration mode not described in these Operating Instructions are not recommended and will void the warranty.

- 1 Press the Page button after the boot-up, to invoke the following screen.
- 2 Use the Up-Arrow and Down-Arrow buttons to scroll to “Log in”. Then press the Enter button.
- 3 When “Logged Out” is displayed, press the Down-Arrow button.
- 4 When “Engineer” is displayed, press the Enter button.
- 5 On the displayed keyboard use the Arrow buttons, to navigate to “Numeric” for entering the access code.
- 6 Press the Enter button, to invoke a decimal keyboard.
- 7 Successively enter the access code digits “1611”: Navigate to “1”, and then press the Enter button. An asterisk replaces the digit in the text box below “Password”.
- 8 Repeat entering the other digits, and press the Enter button each time. After all numbers have been keyed in, press the Page button.
- 9 When “Accept” is displayed, use the Arrow buttons to navigate to “Yes”. Press the Enter button, to invoke the configuration menu.
- 10 Navigate to and select “Instrument”, then press the Enter button.
- 11 Use the Arrow buttons to navigate to “Save and Restore” and press the Enter button.
- 12 Press the Enter button again, navigate to and select “Restore”, and press the Enter button once more.
- 13 On the USB media select the UIC File (with the desired language version) and push the Enter button. The file selected will be loaded (can take a few seconds).
- 14 A message is displayed that the language version has been updated.
- 15 Repeatedly press the Page button, to return to the initial screen and to log out.

Logging out correctly via „Logged out“ matters, as otherwise the control unit will not function properly.

After having logged out, the control unit’s display will show the selected language.

NOTICE

Operation

4.3.2e Notes

Pump fluid

Oil Name	Part No. (for 1L)	Oil Type	Oil Temp (default setting)	Oil Temp (fine-tuning; quality- and process-dependent)
Leybonol 400	L 400 01	PFPE oil	220 °C	200 °C – 230 °C
Leybonol 410	L 410 01	PFPE oil	220 °C	200 °C – 230 °C
Leybonol 500	L 500 01	Mineral oil	250 °C	240 °C – 270 °C
Leybonol 521	L 521 01	Silicone oil	250 °C	220 °C – 260 °C

NOTICE



When using PFPE as pump fluid ensure to reduce the switch-off temperature to 290 °C.

This can be done by integrating a bimetallic switch.

With EEC or fuse box type DIP pumps this can be accomplished via the thermal circuit breaker or the EEC setting.

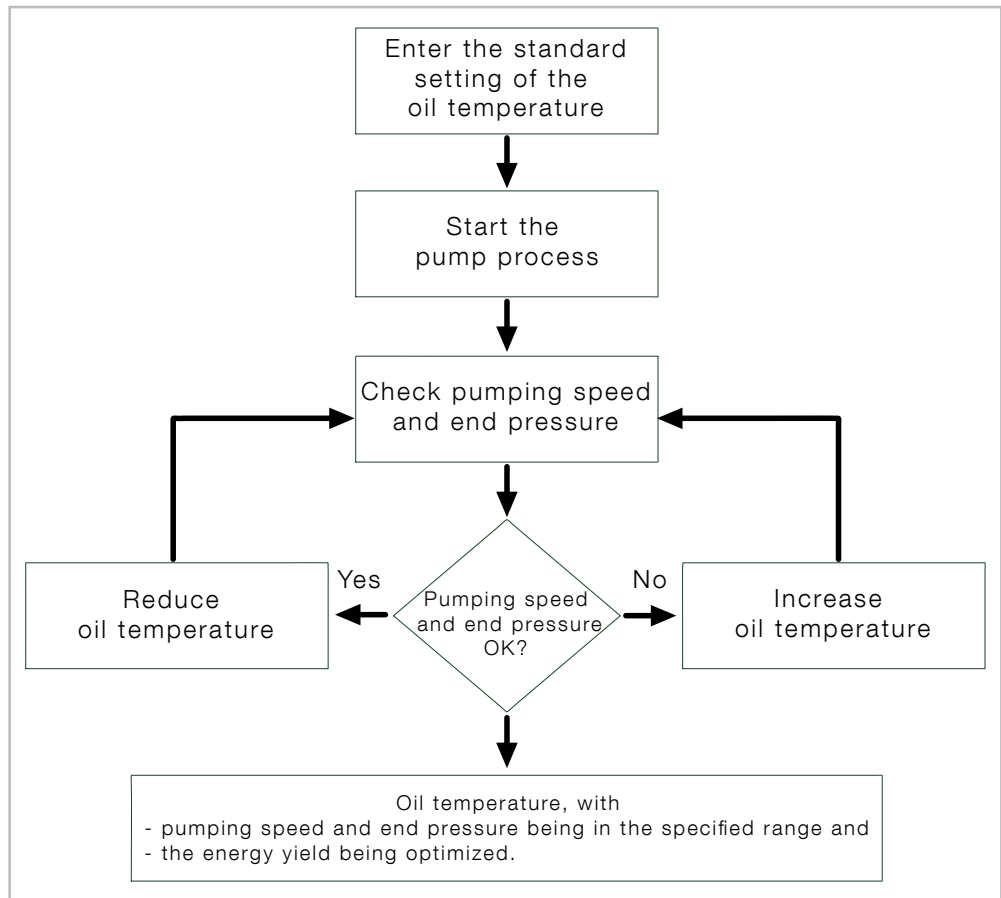

Fig. 10h Fine-tuning the oil temperature

4.3.2f Modbus

The controller supports Modbus and uses TCP port 502 by default. For this, on the EEC's rear panel connect the RJ45 socket with a standard ethernet cable.

Modbus Configuration

You can configure the controller so that it can communicate via the Modbus Transmission Control Protocol.

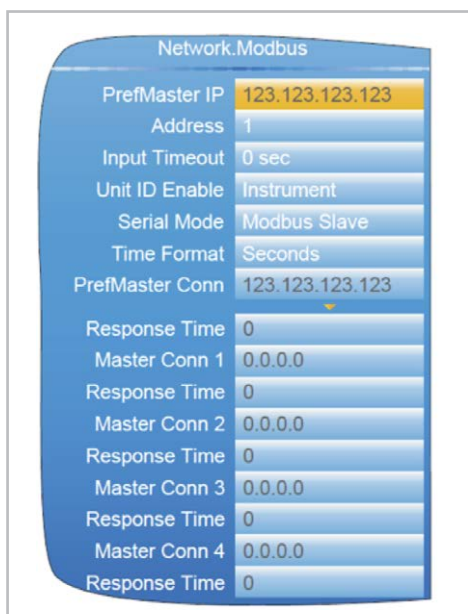

Fig. 10i Modbus TCP Configuration

PrefMaster IP The IP address of the relevant Modbus master. You can establish a connection anytime via the preferred master switch, even if all slave connections (max. 4 for TCP) are engaged.

Address The Modbus address. This address must be unique within the relevant network. The controller responds to this address, and to address 255.

Input Timeout You can enter a value between 0 and 3,600 to set the timeout (in seconds) for the Modbus input channels. If no value is written within the specified period, the value of this channel is set to -9999.0 with a „No Data“ status. Entering „0“ turns off the timeout function when there is no communication / transmission.

Operation

Unit ID Enable Activates/deactivates the Modbus TCP Unit Identity Field.

Strict The Modbus TCP Unit Identity Field (UIF) does not have to match the device's address. The device only responds to hex value „FF“ entered in the UIF. iTools will be looking for this device only at position 255 and then terminates the search.

Loose The Modbus TCP Unit Identity Field does not have to match the device's address. The device will respond to all values entered in the UIF.

Device The Modbus TCP Unit Identity Field must match the device's address; otherwise there will be no answers to messages / requests.

Serial Mode Slave communication via the lateral attached CPI (Configuration Port Interface).

Time Format Selects the time format, ranging from milliseconds and seconds to minutes or hours. Sets the r/w-resolution for time format parameters.

PrefMaster Conn Shows the IP address of the preferred master when connected.

Response Time Shows the response time for a single communication request addressed to the relevant master.

Master Conn 1-4 Shows the IP addresses of other masters connected to the Nanodac.

Modbus Addresses

You can configure the controller so that it can communicate via the Modbus Transmission Control Protocol.

Function	Channel name	Value	Address (decimal)	Data type
Oil temperature	Channel 1 Main PV	actual value (°C)	256	float32
Oil temperature	Loop 1 SP SP1	setpoint (0 – 400 °C)	5724	float32
Heater temperature	Channel 2 Main PV	actual value (°C)	260	float32
Heater power	Loop 1 OP Ch1 Out	actual value (%)	523	float32
Oil temp <100 °C	Channel 1 Alarm 1 Status	alarm status	258	ulnt8
Oil temp >200 °C	Channel 1 Alarm 2 Status	alarm status	259	ulnt8
Heater temperature	Channel 2 Alarm 2 Status	alarm status	263	ulnt8

4.3.2g Web Server

- PC, tablet, and client support for mobiles (using the corresponding browsers)
- supporting Safari, IE9 or higher, and Google Chrome
- the web server is for visualization only

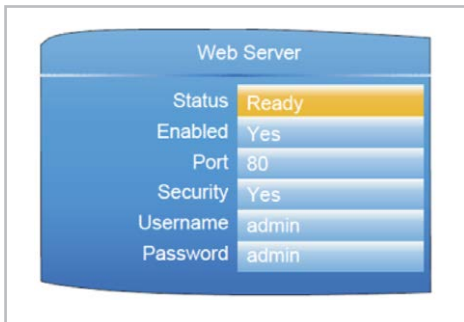

Fig. 10j Web Server Configuration

Status Ready: the Web Server is running.

Inactive: the Web Server is not running.

Connected: a client is connected to the Web Server.

During operation the status may toggle between Ready and Connected.

Enabled Yes/No

Port 80 or 8080

Security Yes/No. Default = „Yes“.

Username Enter your own username. This username is required for logging onto the Web Server. Default = „admin“. The username will only be displayed when „Security“ is set to „Yes“.

Password Enter your own password. This password is required for logging onto the Web Server. Default = „admin“. The password will only be displayed when „Security“ is set to „Yes“.

Operation (for all DIPs; continuation)

If a high-vacuum valve has been installed between the diffusion pump and the vacuum chamber, then this should be opened when the DIP pump is hot only if the pressure in the vacuum chamber is below $5 \cdot 10^{-2}$ mbar.

When inlet and forevacuum temperatures are above the maximum permissible levels it is possible for pump fluid to pass into other parts of the vacuum system.

Unrestricted coolant flow and satisfactory temperature and the quantity and temperature of the pump fluid have to be monitored while the DIP pump is in operation.

Where there is an unacceptable rise in temperature caused, for instance, by failure of the coolant circuit, the built-in thermostat (bimetallic switch) will switch off the heating cartridges at the DIP pump; cf. Section 3.6.1 "Electrical connection at the thermostat". If you have optionally installed a thermostatic safety switch and/or a coolant flow monitor unit these will also switch off.

Air inrush

DANGER



Loss of power supply

The pump fluid is no longer heated in case of failure of the power supply. There is no risk from the DIP. The pump fluid cools down. The risk of the entire system cannot be assessed. In the worst case, the system will be vented rearward and can explode.

The valves must be closed in the event of a power failure.

Air infiltration in an operation-ready, warm diffusion pump are a dangerous condition and must be reliably ruled out.

If electro-pneumatically propelled high- and fore-vacuum valves are used, these must be used shut in the specification "de-energised" and "unpressurised". Also for these valves, the ventilation of a ready-to-operate, hot diffusion pump must be ruled out through appropriate latch circuits.

The components must be connected correctly and properly. Electrical safety examinations, in particular the insulation and protective grounding conductor examination, must be carried out.

Interlock the high-vacuum valve V1 and the forevacuum valve V2 in a way that prevents venting the hot diffusion pump ready for operation.

Regular checks

In order to ensure trouble-free operation of the DIP pump we recommend in the case of normal operation the following regular checks:

Check	Interval	Action	Section
Filling level of the pump fluid	1 week	If required top up oil, be sure to use the same grade of oil	5.2, 5.3
Condition of the pump fluid	1 month	If required change the oil	5.4
Cleaning of the nozzle assembly	1 year	Use suitable solvents, for example, soap-impregnated stainless-steel wool, petroleum ether or acetone; final cleaning with alcohol.	5.5
Cleaning the heat conducting plates of the heater cartridges	1 year	Use a commercial high-pressure cleaner, 4 bar overpressure max.	5.5
Cooling water flow	1 year	If required clean the cooling coils	5.5.5

4.4 Switching Off/Shutting Down

DANGER



Ejection of parts through bursting of the vacuum system due to excessive pressure, caused by malfunction at the gas inlet into the vacuum system

When venting the DIP pump at $> 100\text{ }^{\circ}\text{C}$ danger of explosion!

The pump must be securely locked during operation.

The DIP pump may be vented only if the pump fluid temperature is $< 100\text{ }^{\circ}\text{C}$.

Any rearward venting must only be carried out via a 10 mm opening. The cooled pump should be vented from the high vacuum side.

Turn off the cooling water supply only once the DIP pump has cooled down to $< 100\text{ }^{\circ}\text{C}$.

DIP pump operation with closed high vacuum and fore-vacuum side and simultaneously switched off cooling water supply is a dangerous condition and must be reliably ruled out (e.g. by locking circuit).

CAUTION



Scalding by touching hot equipment or lubricants

Risk of scalding when opening the hot pump through pump fluid steam

Only open fluid drain port or inlet port if the pump is vented and is cooled down to room temperature.

Let cooling water pipes cool down before removing and then shut off the feed line.

Wear suitable protective equipment.

Close the high-vacuum valve V1.

Switch off the pump heating and wait until the DIP pump has cooled down sufficiently (<100 °C).

Close the forevacuum valve V2.

Shut off the coolant supply.

Switch off and vent the forevacuum pump.

For systems without EEC additionally carry out a temperature measurement. Contact Leybold for an optional dial-type thermometer.

Detaching the pump from the system

Danger as a result of contact with toxic decay/reaction products of lubricants, equipment or pumped substances during the maintenance of the pump

In the event of servicing, there may be deposits in the pump.

The pumping of toxic gases and vapours is basically excluded.

The operator is responsible for the assessment of the hazard potential of the process media and/or mixtures. For this purpose, the operator must perform a risk or hazard assessment. The operator must take appropriate measures to ensure that there is no danger to man and the environment.

For this purpose, we recommend that the pump is flushed for a longer time with inert gas before opening. Wear appropriate protective clothing (gloves, goggles, respiratory protection, personal protective equipment).

Avoid body contact with plant oil, process residues and contaminated surfaces. Perform maintenance in preferably clean, dry and well-ventilated rooms.

DANGER



Operation

Switch off and vent the DIP pump in a planned fashion and as described in Section 4.4.

Isolate the DIP pump from the power supply and detach at the electrical connection terminals.

Disconnect the coolant system and use compressed air to blow out the piping network.

Separate the pump's forevacuum and high-vacuum flanges from the system and remove the DIP pump.

Lift the DIP pump only at the lifting eyes.

Open the pump fluid outlet ports (12/5) and drain the pump fluid (oil or PFPE) into a suitable container.

NOTICE



Dispose of the pump fluid properly (may possibly have to be handled as toxic waste).

Pack the pump so that it cannot be damaged during shipment.

Protect the flanges and the coolant connections in particular.

Please observe the precautions set forth in Section 5.1 if you send a pump to Leybold.

An electrical safety test IAW DIN EN 60204 must be carried out, if the pump or electrical parts were replaced. The compliance with the corresponding technical documents (PE conductor continuity, functional tests) must be checked.

Maintaining in stock

Maintain the pump in stock so that it is dry and not exposed to frost. The cooling coils need to be blown out and must be dry. **Beforehand** blow out the cooling lines with compressed air.

Keep the pump in stock standing upright. When storing the pump for longer periods or in environments with high humidity conditions foil the pump and use bags with desiccant, to protect it against corrosion and ageing of the heater cartridges!

Pumps having a filling of PFPE should be sealed off in a gas-tight manner and vented with nitrogen.

5 Maintenance

Danger as a result of contact with toxic decay/reaction products of lubricants, equipment or pumped substances during the maintenance of the pump

In the event of servicing, there may be deposits in the pump.

The pumping of toxic gases and vapours is basically excluded.

The operator is responsible for the assessment of the hazard potential of the process media and/or mixtures. For this purpose, the operator must perform a risk or hazard assessment. The operator must take appropriate measures to ensure that there is no danger to man and the environment.

For this purpose, we recommend that the pump is flushed for a longer time with inert gas before opening. Wear appropriate protective clothing (gloves, goggles, respiratory protection, personal protective equipment).

Avoid body contact with plant oil, process residues and contaminated surfaces. Perform maintenance in preferably clean, dry and well-ventilated rooms.

Vacuum pumps which are operated with the lubricant Perfluorinated Polyether (PFPE) may in the case of thermal decomposition release toxic and corrosive gases.

Wear appropriate protective clothing (gloves, goggles, respiratory protection, personal protective equipment).

Avoid body contact with plant oil, process residues and contaminated surfaces. Perform maintenance in preferably clean, dry and well-ventilated rooms.

Do not smoke with PFPE on your fingers.

Electric shock through direct or indirect contact of live parts

There are hazardous voltages present on the mains cables (danger to life).

Before carrying out maintenance or service work on the product, take it off the mains supply. After mains power off, wait for 5 minutes!

DANGER



DANGER



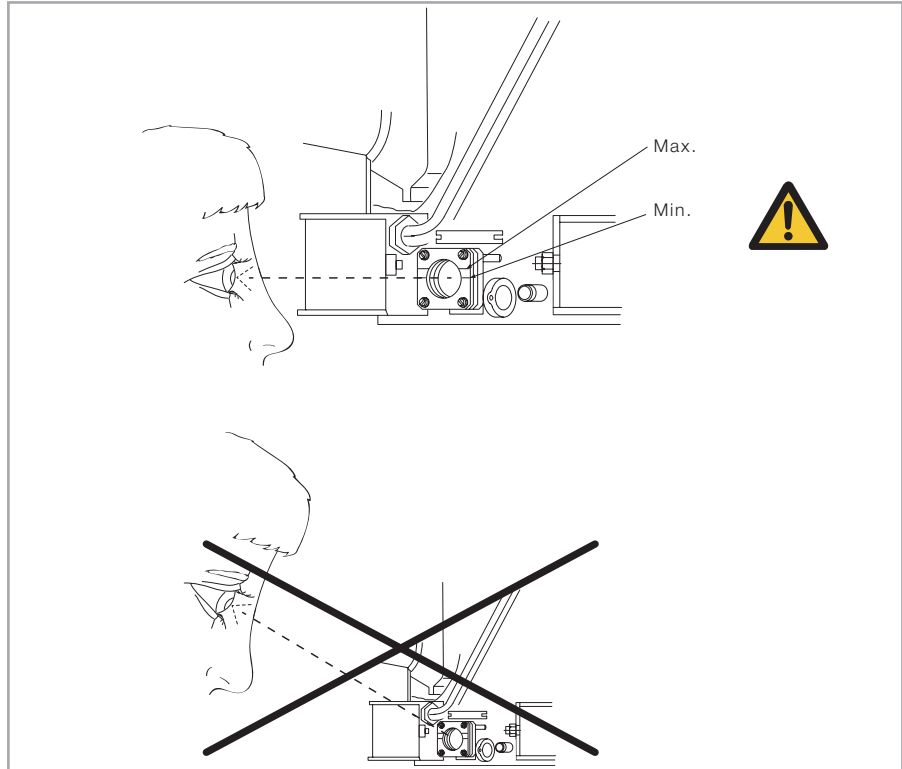

Fig. 11 Checking the level of the pump fluid

Contamination

5.1 Leybold Service

Whenever you send us in equipment, indicate whether the equipment is contaminated or is free of substances which could pose a health hazard. If it is contaminated, specify exactly which substances are involved. You must use the form we have prepared for this purpose.

Form

This form is available from www.leybold.com/ -> Downloads -> [Download Documents](#).

Attach the form to the equipment or enclose it with the equipment.

This statement detailing the type of contamination is required to satisfy legal requirements and for the protection of our employees.

We must return to the sender any equipment which is not accompanied by a contamination statement.

5.2 Checking the Pump Fluid Level

The fluid fill level can be read at the sight glass on the DIP pump. There are markings for the minimum and maximum levels at the sight glass. When the DIP pump is running the fill level should be at the max. mark of the sight glass (slightly oscillating). Operating the pump for longer periods with lower oil levels (at or below the min. mark) will lead to overheating resulting in premature failures of and problems with replacing heater cartridges.

The oil fill level can be checked exactly only when the pump is cold and vented. In order to correctly determine the oil level, read off the filling level at eye level.

The fill level will fluctuate hardly at all during normal operation. There may be differences, depending on the oil used. If the DIP pump has to be aired frequently or is operated with a vacuum chamber that is vented regularly (batch operation), then we recommend keeping the fluid level at the maximum level.

If the heated pump fluid falls rapidly and below the expected fill level (cf. sight glass), the oil return line is blocked and the pump must be cleaned. If during operation the pump loses oil too fast, check the valve velocity of the high-vacuum valve. A gas throughput being too high or gas inrushes may be possible other causes (leakages).

5.3 Topping up Pump Fluid

The level of the pump fluid must not be allowed to drop below the minimum mark. Top up as required.

Ejection of parts through bursting of the vacuum system due to excessive pressure, caused by malfunction at the gas inlet into the vacuum system

When venting the DIP pump at $> 100\text{ }^{\circ}\text{C}$ danger of explosion!

The pump must be securely locked during operation.

The DIP pump may be vented only if the pump fluid temperature is $< 100\text{ }^{\circ}\text{C}$.

Any rearward venting must be ruled out. The cooled pump should be vented from the high vacuum side.

Turn off the cooling water supply only once the DIP pump has cooled down to $< 100\text{ }^{\circ}\text{C}$.

DIP pump operation with closed high vacuum and fore-vacuum side and simultaneously switched off cooling water supply is a dangerous condition and must be reliably ruled out (e.g. by locking circuit).

Scalding by touching hot equipment or lubricants

Risk of scalding when opening the hot pump through pump fluid steam

Only open fluid drain port or inlet port if the pump is vented and is cooled down to room temperature.

Let cooling water pipes cool down before removing and then shut off the feed line.

Wear suitable protective equipment.

Cold and vented pump

Loss of pump fluid

DANGER



CAUTION



Maintenance

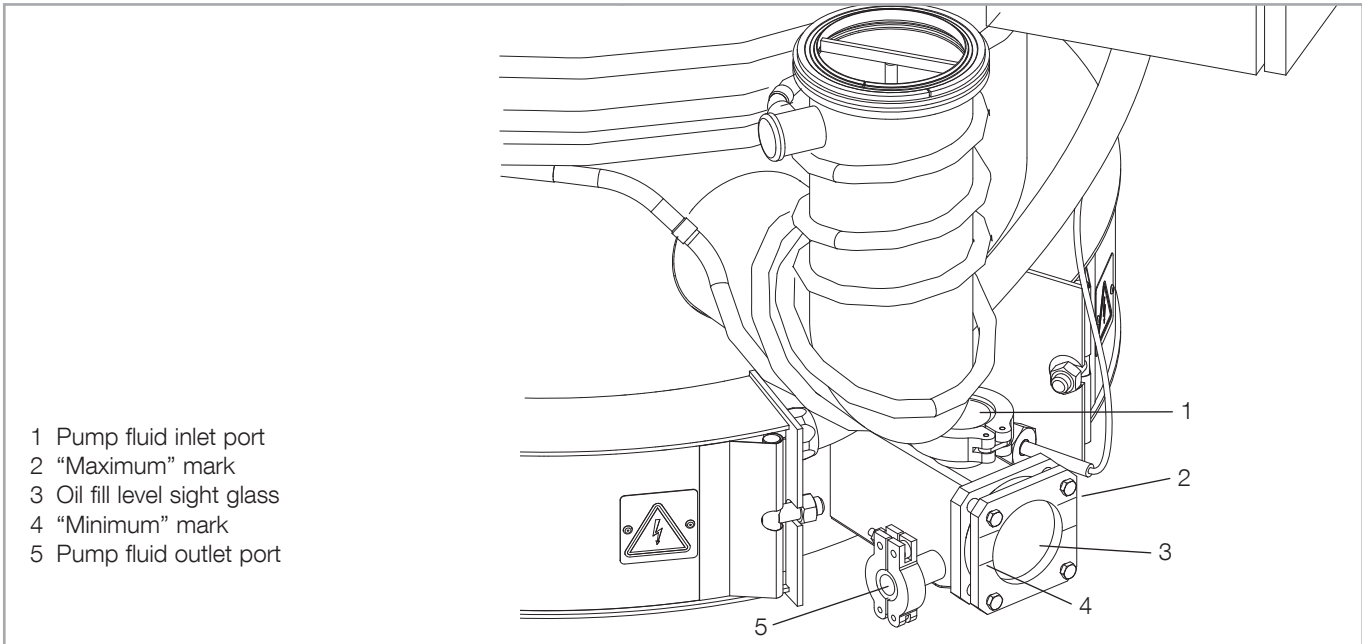

Fig. 12 Oil level sight glass with pump fluid inlet and outlet ports

CAUTION



Hazard of slipping, tripping or falling due to oil leakage from the pump

Depending on the work process, oil may escape from the pump.

Check the pump for any oil that has run out. Take appropriate security measures.

- Switch the pump off, wait for it to cool down and vent it (cf. Section 4.4).
- Read off the filling level at eye level. Be sure to use the same grade of pump fluid.
- Open the inlet port (12/1) and fill in the pump fluid ensuring that the maximum mark is not exceeded.
- We recommend that you replace the gasket at the inlet port (15/43).
- Close the inlet port.

5.4 Exchanging the Pump Fluid

Unused pump fluid (mineral oil and silicone oil) is as translucent and clear as water. When it changes its colour to “honey yellow” it will have to be exchanged.

When using PFPE as intended, PFPE is not subject to ageing. It must only be changed if it is contaminated by the process gas. It can only be determined for each individual case when the PFPE is so contaminated that it must be changed.

Prior to using PFPE (Leybonol LVO 400 or LVO 410) consult with Leybold.

NOTICE

- Switch the pump off, wait for it to cool down and vent.
- Open the drain port and drain the pump fluid into a suitable vessel. Leave the drain port open for at least 30 minutes so that as much pump fluid as possible can drain out.
- Each time when exchanging the pump fluid we re-commend that you replace the two gaskets at the filling port (15/43) and the drain port (15/42).
- Close the drain port.
- Open the inlet port and fill in the pump fluid.
- The quantities of fluid required will be found in Section 1.3, “Technical Data”.
- Use a litre gauge to measure the quantity of pump fluid and fill the pump fluid into the pump. When filling the pump for the first time or when filling it after cleaning, we recommend always to fill the pump up to its maximum.
- After having filled in the pump fluid, wait a few minutes for the pump fluid to spread and then read off the oil level at the oil level sight glass. In order to correctly determine the oil level, read off the filling level at eye level.
- Close the inlet port.
- There exists the risk of slipping when spilling oil during topping-up. Clean-up the affected areas and properly dispose the oil!

For disposing of waste oil refer to Section 8.

5.5 Cleaning the Pump

The inner surfaces of the pump should be cleaned at least once a year. Moreover, they must be cleaned when filling in a different grade of pump fluid.

The pump will have to be dismantled to do so.

5.5.1 Dismantle Pump

Disconnect the power supply and coolant circuit (see Section 4.4, "Switching off").

Open the pump fluid outlet port (15/42) and allow the pump fluid to drain. Separate the pump's forevacuum and high-vacuum flanges from the system.

Remove the cold cap baffle (15/19).

Unscrew the nut (15/31) and remove the washer (15/32). Unscrew the mounting bolt (15/35).

Carefully lift the cold cap baffle and pull it out of the pump housing.

Loosen the connection ports (15/30) with by tapping lightly with a rubber hammer or wooden mallet if necessary.

When removing the baffle carefully remove the two insulating washers (15/34) and the spacer (15/36).

DIP 20 000: Grasp the nozzle assembly at the first stage (13/6) and lift it out of the pump housing.

DIP 30 000 and 50 000: Lift out the nozzle assembly using the lifting eyes at the second stage.

5.5.2 Cleaning the Pump

The nozzle assembly and the inner parts of the pump may be cleaned with a commercial steam cleaner.

NOTICE



The pressure of the steam cleaner may

- only **amount to 4 bar** when cleaning the heat conducting panels of the heater inserts (risk of breaking the copper lamellae).
- only **amount to 10 bar** for the remainder of the pump.

Stubborn dirt (burnt-in residues of the pump fluid) may be removed with a suitable solvent or with fine grain detergents or fine emery paper.

Place the pump at a slight angle (ensure that it can not topple over) so that the cleaning fluid can run out. At the end of the cleaning process clean all inner surfaces with a commercial hot air fan.

5.5.3 Oil Level Sight Glass

Remove the screws at the flange mount (15/39) to clean the oil level sight glass (15/41) in the assembly (15/29).

We recommend replacing the two O-rings (15/38) in front of and behind the sight glass during assembly.

Pay attention to correct positioning of the marking at the sight glass cover. The marking line indicating the upper level for the pump fluid must be located above the middle of the oil level sight glass. The marking lines are always placed on the oil glass frame's right side. Additionally, the frame is marked with a number that has to be readable above the oil glass.

Oil glass frames of different pumps must not be swapped, as pumps may be configured for individual filling levels.

If arrows are present on the cover frame, these must point downwards.

NOTICE

5.5.4 Assembling the Pump

When assembling the pump ensure that the individual components are again mounted in the correct order (see Fig. 15).

The nozzle assembly may not be dismantled. Please contact our service, if you notice defects at the nozzle assembly. Deformations at the nozzle assembly are an indicator for serious air ingress during pump operation.

NOTICE

Install the nozzle assembly centered in the pump housing. Check to ensure that it is seated in the center of the high-vacuum flange (15/15).

Mount the cold cap baffle (15/19), paying particular attention to correct seating of the gasket rings (15/33) for the coolant liquid port.

Pay attention to correct positioning of the two insulating washers (15/34) and the spacer (15/36) between the cold cap baffle and the nozzle assembly.

Close the pump fluid outlet port (15/42) and reinstall the DIP pump in the system, being sure that it is vacuum-tight.

Pay attention to correct positioning, properties and cleanliness for all gaskets. Only use new heat resistant gaskets (FKM, Silicone).

NOTICE

Install new pump fluid at the pump fluid filling port (15/43). See Section 1.3, "Technical Data", for specifications on the amount of pump fluid required.

Maintenance

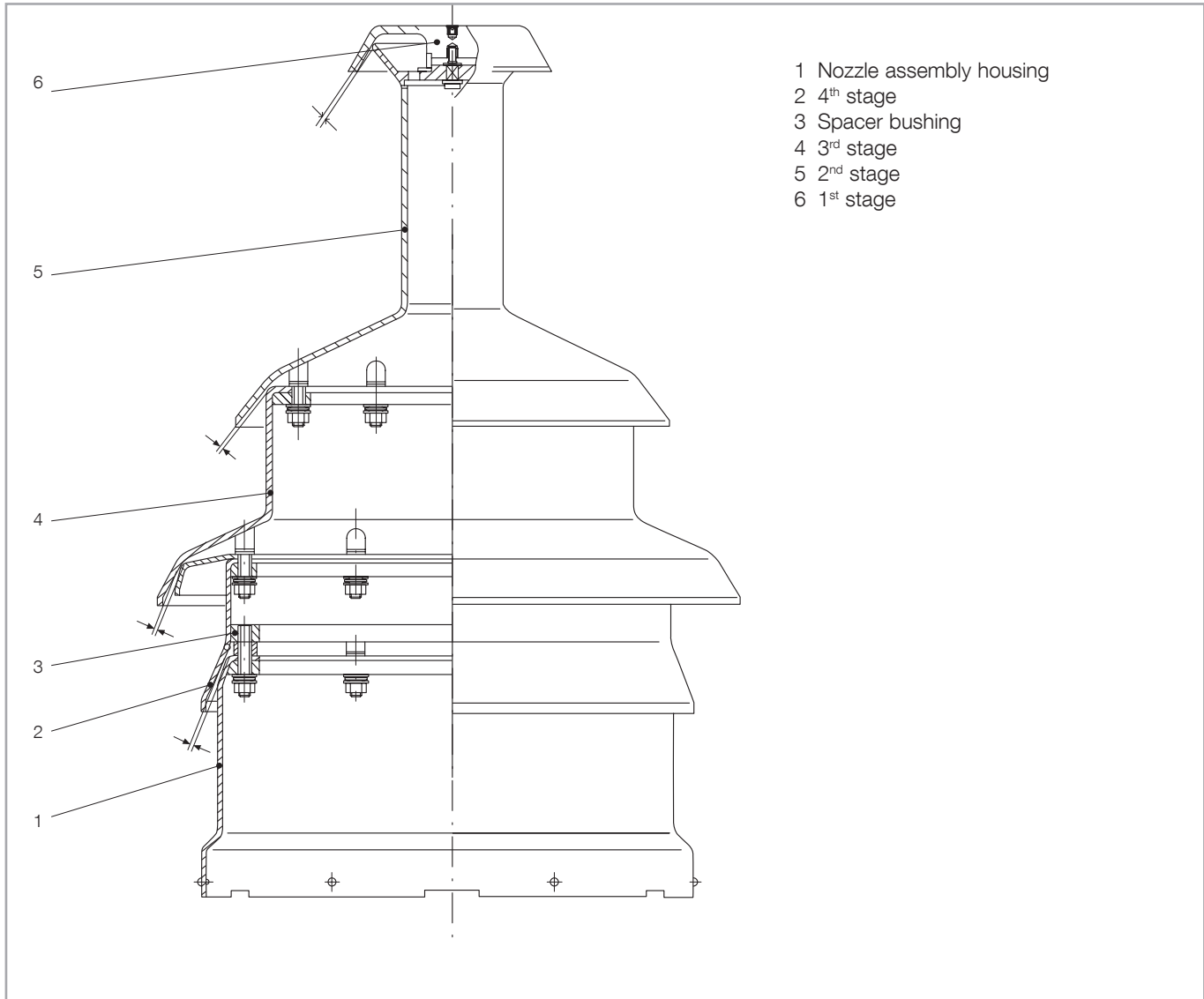

Fig. 13 Nozzle assembly for the DIP 20 000; other models are similar

5.5.5 Cleaning the Cooling Coils

Clean the cooling coils with a commercial decalcifier based on formic acid or ethanoic acid.

NOTICE



Do not use any chlorine based decalcifier since this will damage the cooling coils due to crevice corrosion.

5.6 Replacing the Heating Cartridges

High electrical fault currents due to moisture absorption by mineral insulating material of the heating elements

The hygroscopic insulation of the heating element could lead to a burn-out of the heater cartridge. Risk occurs through longer shut-off cycles and humid ambient conditions.

Take note of the installation instructions for the replacement and connection of the heater cartridge.

Check stock before changing/inserting (measured value: 49 to 55 ohms) and degas if necessary.

In case of standstill, check heater cartridge after one year.

The heating cartridges contain magnesium oxide (MgO) and thus attract humidity. For this reason keep the replacement heater cartridges in dry rooms only or in plastic bags which are sealed air-tight. If the heater cartridges have attracted humidity, they may be dried in a drying oven for 8 hours at 180 °C.

Only install heater cartridges which are dry.

Annually check the heater cartridges (metered resistance: 49 – 55 ohm). Depending on the load we recommend to de-install the heater cartridges and apply never-seize spray on an annual basis. This prevention measure facilitates exchanging cartridges in the event of replacement.

Switch off the DIP pump in preparation for replacing the heating cartridge. Prevent reconnection (lockout / tagout). Remove the sheet metal cladding at the base of the pump (15/27) by loosening the fixing screws (15/37). Disconnect the leads for the defective heating cartridge (15/45), remove the fixing clamp of the cartridge (15/47), and pull the heating cartridge straight out of the heater well, **without** rotating it.

If the heater cartridge can not be pulled out manually, apply penetrating oil (e.g. WD-40) into the gap of the heater well and allow to work for about an hour. Then try again to pull out the cartridge manually. If this is not possible use the withdrawal tool (cf. Fig. 14; P/N **502459**; manual for the tool is enclosed with the supplied equipment); or contact our service.

Before installing the heater cartridge widen the heating pipe by 20^{H7} mm with a reamer and then clean it with a brush; the surface must be even and clean (chips, abrasions, oil and other residues have to be removed).

CAUTION



NOTICE



Maintenance

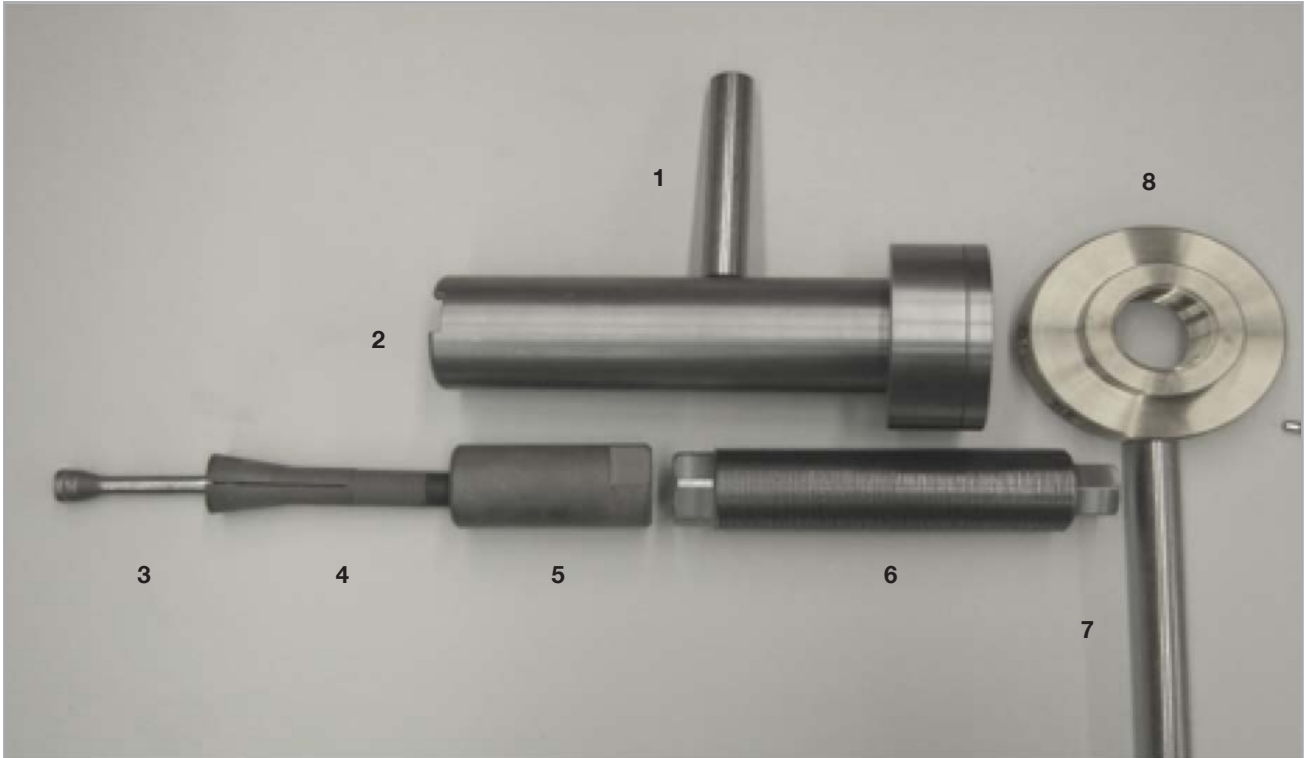

Item	Description	Ref. No.	Item.	Description	Ref. No.
1	Bar No. 1 (w/ thread M12)	500 008 653	5	Clamping chuck	500 008 651
2	Extraction tube	500 008 652	6	Extraction mandrel	500 008 649
3	Mandrel	500 008 648	7	Bar No. 2	500 008 693
4	Clamping collet	500 008 650	8	Extraction nut	500 008 694

Fig. 14 Withdrawal tool for heating cartridges (P/N **502459**)

The replacement heating cartridge will have to be sprayed with a temperature-resistant lubricating substance (Never-Seize; P/N E06025124); see Section 7, "Wearing Parts".

NOTICE



In order to avoid any danger of electrical problems, **do not** apply the never-seize spray to a 20 mm length of the cylindrical section of the cartridge at the connection end.

The spray film which is applied must be distributed evenly and should fill the entire air gap between the cartridge and the inside of the heater well. The lubrication substance enhances protection against the cartridge seizing during installation and removal and promotes heat transfer from the heating cartridge to the heater well.

Rotate and slide the heating cartridge (15/45) to insert it into the heater tube. When inserting the heater cartridge there must be no mechanical resistance. If necessary once more widen the heating pipe by 20^{H7} mm with a reamer and then clean it. Finally provide the electrical connections.

Subsequent assembly is in the reverse order to that described above. The inside of the heater well must not be damaged. Notify our Customer Service Department if the heater well should suffer serious damage.

Hazards through emission of harmful gases/vapours

During the start-up and the new installation of the heater cartridge, smoke and an unpleasant smell may develop. Therefore, turn on new pumps and pumps after successful servicing of the heater cartridges only in well-ventilated areas. Avoid direct contact with the smoke or gases that can develop during start-up.

DANGER



Maintenance

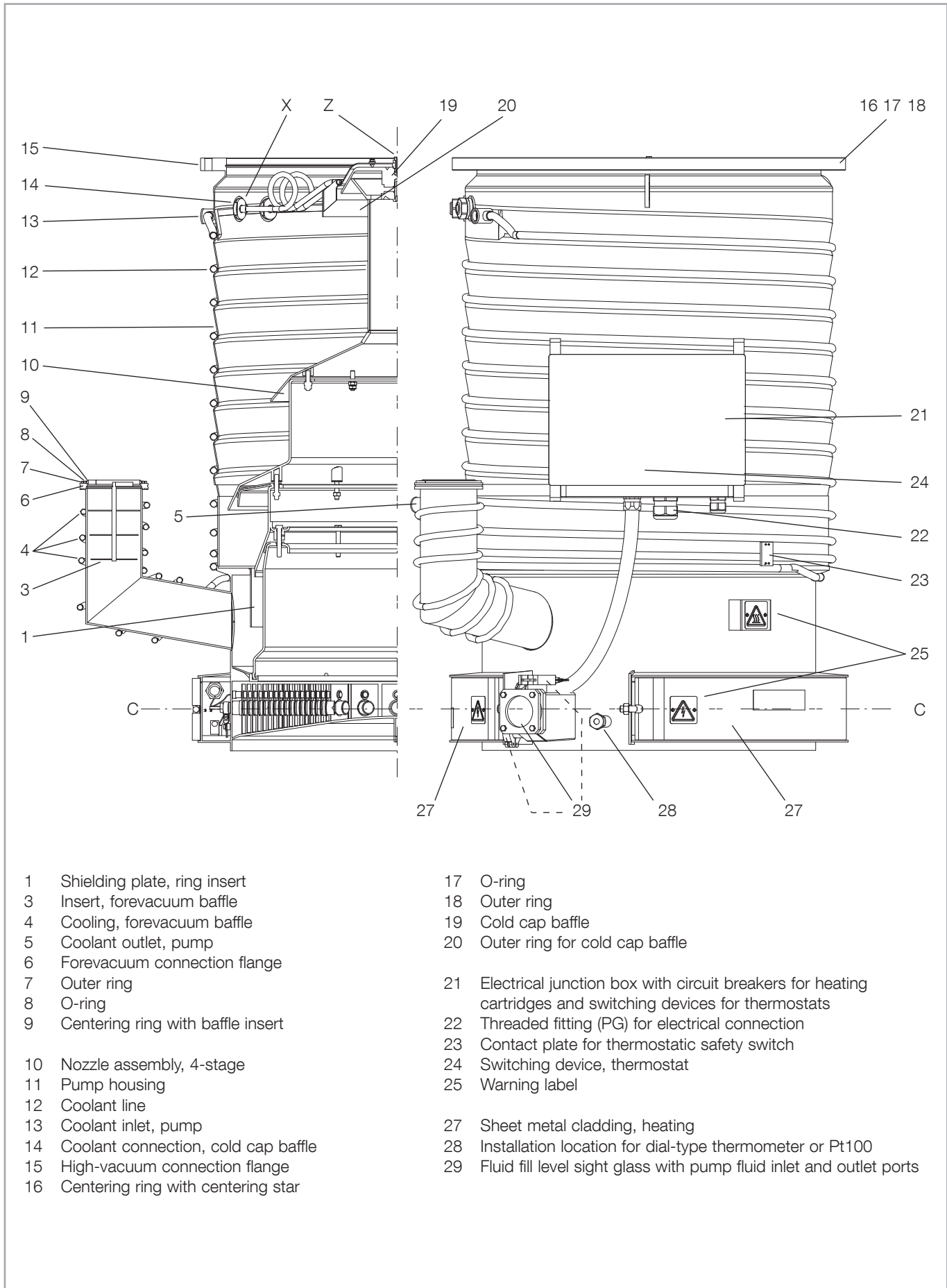

- | | | | |
|----|-------------------------------------|----|--|
| 1 | Shielding plate, ring insert | 17 | O-ring |
| 3 | Insert, forevacuum baffle | 18 | Outer ring |
| 4 | Cooling, forevacuum baffle | 19 | Cold cap baffle |
| 5 | Coolant outlet, pump | 20 | Outer ring for cold cap baffle |
| 6 | Forevacuum connection flange | 21 | Electrical junction box with circuit breakers for heating cartridges and switching devices for thermostats |
| 7 | Outer ring | 22 | Threaded fitting (PG) for electrical connection |
| 8 | O-ring | 23 | Contact plate for thermostatic safety switch |
| 9 | Centering ring with baffle insert | 24 | Switching device, thermostat |
| 10 | Nozzle assembly, 4-stage | 25 | Warning label |
| 11 | Pump housing | 27 | Sheet metal cladding, heating |
| 12 | Coolant line | 28 | Installation location for dial-type thermometer or Pt100 |
| 13 | Coolant inlet, pump | 29 | Fluid fill level sight glass with pump fluid inlet and outlet ports |
| 14 | Coolant connection, cold cap baffle | | |
| 15 | High-vacuum connection flange | | |
| 16 | Centering ring with centering star | | |

Fig. 15a Overall view of the DIP 20 000; other models are similar

Maintenance

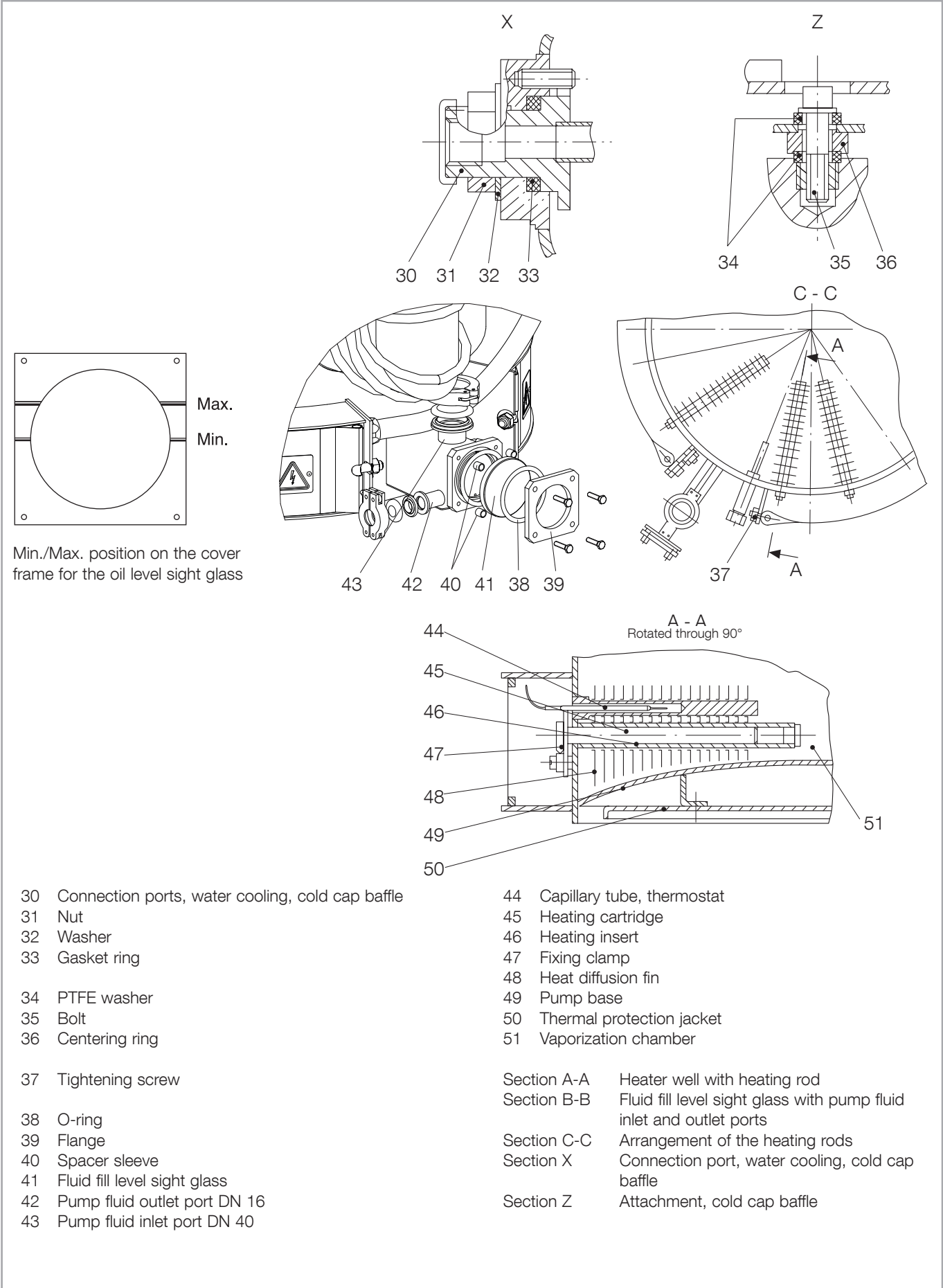

Fig. 15b Overall view of the DIP 20 000; other models are similar

Troubleshooting

6 Troubleshooting

The ultimate total pressure specified in Section 1.3, "Technical Data", will be attained under the following conditions:

The chamber must be leak-tight and bake-out procedures should be possible, if this is at all feasible. The interior surfaces must be clean.

The gases liberated by the sealing elements used in the unit are to be kept to a minimum, which means that FPM gaskets are to be used instead of NBR or silicone sealing rings. If very low working pressures are required, then metal seals will preferably be installed.

If the ultimate pressure is obviously not attained although the conditions given here are all satisfied, then the following defects may be present:

Malfunction	Possible cause	Remedy	Responsibility
Insufficient pump fluid	Heating units switch off and on at insufficient pump fluid level.	Top up with pump fluid.	Operator/ Maint. personnel
Pump fluid contaminated	Pump fluid has decomposed as a result of frequent air ingress or there are contaminants originating from the apparatus.	Clean the DIP pump; replace the pump fluid.	Maint. personnel
Pump fluid crystallises (silicon oil)	Cleaning agents unsuitable!	Do not use acetone, benzole or acetic acid as cleaning agents! If there's no other option, wash with alcohol and clean pump afterwards.	Maint. personnel
	Process- or product waste (PVC plasticisers) or high oxygen environment	Clean the DIP pump; replace the pump fluid.	
Pump fluid „vanishes“ after heating up	Return line blocked	Clean the return line	Maint. personnel
Insufficient heater output	Line voltage too low; heating cartridge defective.	Replace the defective heating cartridge.	Maint. personnel/ Leybold Service
Insufficient cooling; pump runs too hot	Coolant circuits connected incorrectly	Connect the coolant circuits as described in Section 3.4.	Maint. personnel
	Insufficient coolant pressure	Raise the coolant pressure to a maximum of 6 bar	Operator/ Maint. personnel
	Clogged lines, scale deposits	Clean the lines, run water through the system in the reverse direction. Do not use any de-scaling products containing chlorine compounds; use commercially available products based on formic or acetic acid.	Maint. personnel
Pump achieves neither full pumping speed nor satisfactory ultimate pressure.	Nozzle assembly assembly improperly mounted.	Remove and clean the nozzle assembly and then carefully reinstall (see Section 5.5). Ensure that the nozzle assembly is centered in the DIP pump.	Maint. personnel/ Leybold Service
	Insufficient forevacuum.	Examine the forevacuum line for potential leaks and seal where needed. The required forevacuum pressure upline from the diffusion pump must be ensured.	Maint. personnel
	Device leaking or soiled.	Use a leak tester to examine the apparatus; clean thoroughly, dry and bake out if indicated.	Maint. personnel
	Oil contaminated or aged.	Change the oil.	Maint. personnel
	Pump is not suspended vertically / standing flat and level.	Connect the pump correctly.	Maint. personnel
High pump fluid loss	Gas throughput too high.	Check the process.	Operator/ Maint. personnel
	High-vacuum valve leaky.	Clean or repair the valve.	Maint. personnel

Wearing Parts

7 Wearing Parts and Original Spare Parts

Item in Fig. 15	DIP 20000	DIP 30000	DIP 50000	Designation, Dimension, Material	Part No.	Comments
14, 33	2	2	2	O-ring 25x2,5 NBR	ES23950105	Pump body doolant port, cold cap baffle
42	1	1	1	O-ring 18x5; FPM	ES210605	DN16 KF fluid outlet port
43	1	1	1	O-ring 42x5; FPM	ES210625	DN40 KF fluid inlet port
38	2	2	2	O-ring 65x5; FPM	ES23970129	Fill level sight glass
8	1			O-ring 100 x 5; FPM	ES210645	DN 100 ISO-K
8		1	1	O-ring 150 x 5; FPM	ES210650	DN 160 ISO-K
17	1			O-ring 640 x 8; FPM	E210741	DN 630 ISO-F
17		1		O-ring 820 x 8; FPM	E210746	DN 800 ISO-F
17			1	O-ring 1023 x 8; FPM	E210751	DN1000 ISO-F
16, 17, 18	1			Vac. sealing disk, complete Al/CR (neoprene)	17116	DN 630 ISO-F
16, 17, 18		1		Vac. sealing disk, complete Al/CR (neoprene)	17117	DN 800 ISO-F
16, 17, 18			1	Vac. sealing disk, complete Al/CR (neoprene)	17118	DN1000 ISO-F
38, 42	2 1	2 1	2 1	Silicone O-ring 65x5 Silicone O-ring 18x5	EK6526563	Fill level sight glass DN16 KF fluid outlet port
19, 20	1			Cold cap baffle ø285 x 102	20005466	
19, 20		1		Cold cap baffle ø330 x 116	20005464	
19, 20			1	Cold cap baffle ø374 x 113	20005465	
9	1			Forevacuum baffle ø96 x 162	20005494	DN 100 ISO-K
9		1	1	Forevacuum baffle ø150 x 228	20005495	DN 160 ISO-K
9	1			Forevacuum baffle DN 100	E6526783	DN 100 ISO-K new design
9		1	1	Forevacuum baffle DN 160	E6526784	DN 160 ISO-K new design
10	1			Nozzle assembly, complete Al	E20005440	
10		1		Nozzle assembly, complete Al	E20005443	
10			1	Nozzle assembly, complete Al	E20005444	
34, 35, 36	1			Insulating washers, set 15x5 PTFE	E20005472	Thermal insulation,cold cap baffle
34, 35, 36		1	1	Insulating washers, set 20x8 PTFE	E20005433	Thermal insulation,cold cap baffle
38, 40, 41	1	1	1	Fill level sight glass, mounting set	20005470	incl. spacer sleeves; O-rings and looking glass
40, 21	1	2	2	Built-in thermostat incl. measurement sensor and switching device	E20012573	Overtemperature switching device ø9mm sensor
40	1	2	2	Temperature switching device 330 °C	E6519795	Bimetallic switch
40	1	2	2	Sensor contact	E6519789	Sensor ø9mm
28	1	1	1	Double Pt100 for DIP with 3m cable	E6513193	Oil temperature sensor
28	1	1	1	Pt100 w/o cable w. plug	E20002958	Oil temperature sensor
23	1	1	1	Cooling water temp. switching device	12284	Cooling water monitoring >50°C

Wearing Parts

Continued

Item in Fig. 15	DIP 20000	DIP 30000	DIP 50000	Designation, Dimension, Material	Part No.	Comments
45	11	17	22	Heating cartridge ø20x200	E20000862	200V / 1000W
45	11	17	22	Heating cartridge ø20x200	E20005459	230V / 1000W
45	11	17	22	Heating cartridge ø20x200	E40055109	230V / 1100W
45	11	17	22	Heating cartridge ø20x200	E40055111	230V / 1250W
45	11	17	22	Heating cartridge ø20x200	E500001172	270V / 1000W
45	1	1	2	Heating cartridge ø20x200 with Pt100	E6513191	230V / 1000W
45	1	1	2	Heating cartridge ø20x200 with Pt100	E6516641	270V / 1000W
	1	1	2	Spray can Anti-Seize 1200°C	E06025124	Temperature-resistant lubricant
21	1			Electrical junction box, complete DIP 20000	E20012633	incl. pump wiring and safety relais
21		1		Electrical junction box, complete DIP 30000	E20012634	incl. pump wiring and safety relais
21			1	Electrical junction box, complete DIP 50000	E20012635	incl. pump wiring and safety relais
46	11	17	22	Heater insert w/o tube	E20006936	for weld-in
46	1	1	2	Heater insert with tube	E20012572	for weld-in
	1	1	1	Cabinet fan 230V/50-60Hz	E6515261	
	1	1	1	Cabinet fan 115V/50-60Hz	E6519134	
	1	1	1	Cabinet fan 24V/55/66m³/h	E6533050	
	4	6	8	Terminal 4-pin	EK57020313	Terminal block
	Z	Z	Z	Flow control sensor w/ display	500006623	
	Z	Z	Z	Flow control sensor	6507100	
	Z	Z	Z	EEC plug-EEC w/ 10m cable	503646V001	
	1	1	1	EEC (replacement)	503646V003	
	Z			EEC retrofit kit for DIP20000	503647V001	
	Z			EEC retrofit kit for DIP20000 US	503647V002	
		Z		EEC retrofit kit for DIP30000	503648V001	
		Z		EEC retrofit kit for DIP30000 US	503648V002	
			Z	EEC retrofit kit for DIP50000	503649V001	
	1	1	1	Eurotherm Nanodac control unit recorder	E6506806	
... Fig. 7c				Designation, Dimension, Material	Part No.	
1	1	1	1	Cabinet fan 24V	E6533050	
2	1	1	1	Solid state relay with cooling body	E6533049	
3	1	1	1	Eurotherm Nanodac / 24 VDC	E6532118	
7	12	18	24	Heater circuit breaker 6.3 A	E6509414	
7	12	18	24	Heater circuit breaker 6.3 A (20 pcs.)	ES6509414	

8 Waste Disposal

The equipment may have been contaminated by the process or by environmental influences. In this case the equipment must be decontaminated in accordance with the relevant regulations. Leybold offers this service at fixed prices. Further details are available on request.

Danger as a result of contact with toxic decay/reaction products of lubricants, equipment or pumped substances during the maintenance of the pump

In the event of servicing, there may be deposits in the pump.

The pumping of toxic gases and vapours is basically excluded.

The operator is responsible for the assessment of the hazard potential of the process media and/or mixtures. For this purpose, the operator must perform a risk or hazard assessment. The operator must take appropriate measures to ensure that there is no danger to man and the environment.

Vacuum pumps which are operated with the lubricant Perfluorinated Polyether (PFPE) may in the case of thermal decomposition release toxic and corrosive gases.

For this purpose, we recommend that the pump is flushed for a longer time with inert gas before opening. Wear appropriate protective clothing (gloves, goggles, respiratory protection, personal protective equipment).

Avoid body contact with plant oil, process residues and contaminated surfaces. Perform maintenance in preferably clean, dry and well-ventilated rooms.

Do not smoke with PFPE on your fingers.

Separate clean components according to their materials, and dispose of these accordingly. Leybold offers this service. Further details are available on request.

When sending any equipment to Leybold, observe the regulations given in Section "5.1 Leybold Service".

Contamination

DANGER



Waste Disposal

Disposing of spent fluid

The owners of used fluid are responsible for its proper disposal.

Spent fluid from vacuum pumps may not be mixed with other substances.

Spent fluids from vacuum pumps (Leybold's petroleum-based oils) which are contaminated only as a result of normal wear and tear due to the effects of atmospheric oxygen, elevated temperature and mechanical strain can be disposed of in the same way as used motor oils.

Spent oils from vacuum pumps which were contaminated with other substances will have to be marked to identify the contaminant and stored and disposed of as toxic wastes.

European, national and local regulations concerning the disposal of waste need to be observed. The waste must only be handled and disposed of through an approved waste disposal vendor.

PFPE from vacuum pumps may be regenerated, if required, and provided the quantities are large enough. For this, please contact us for assistance.

Annotation

Technical Data	DIP 20000	DIP 30000	DIP 50000
Power supply ($\pm 10\%$)	400 V / 3Ph / PE	400 V / 3Ph / PE	400 V / 3Ph / PE
Frequency	50/60 Hz	50/60 Hz	50/60 Hz
Rated output power	12 KW	18 KW	24 KW
Rated current	17.3 A	26 A	34.7 A
Control voltage	24 VDC	24 VDC	24 VDC
Wire colors marking			
Main circuit 115/230 400/460 VAC		Black	
Main circuit neutral		Azure RAL 5015	
Control circuit 230 VAC		Red	
Control circuit 230 VAC neutral		Red / White	
Control circuit 24 VDC		Gentian blue RAL 5010	
Control circuit 24 VDC neutral		Gentian blue RAL 5010 / White	
Analog circuits 0...10 V		White	
Analog circuits 4...20 mA		Brown	
Data lines		Violet	
External voltage / potential-free contacts		Orange	
Protective earth		Green / Yellow	
All wires not signed in the:			
Main circuit		1.5 mm ² / AWG 16	
Control circuit		1.0 mm ² / AWG 18	
Core type to be used:		Standard	

EU Declaration of Conformity

(Translation of original Declaration of Conformity)

The manufacturer: Leybold GmbH
Bonner Strasse 498
D-50968 Köln
Germany

herewith declares that the products specified and listed below which we have placed on the market, comply with the applicable EU Directives. This declaration becomes invalid if modifications are made to the product without agreement of Leybold GmbH.

Product designation: Oil Diffusion Pumps

Type designation: DIP 3000, DIP 8000, DIP 12000, DIP 20000, DIP 30000, DIP 50000

The products complies to the following Directives:

Electromagnetic Compatibility (2014/30/EU)

The following harmonized standards have been applied:

EN 61000-6-2:2005/AC:2005	Electromagnetic compatibility (EMC) - Part 6-2: Generic standards - Immunity for industrial environments
EN 61000-6-4:2007/A1:2011	Electromagnetic compatibility (EMC) - Part 6-4: Generic standards - Emission standard for industrial environments

Documentation officer: Leybold GmbH, Bonner Straße 498, D-50968 Köln
Herbert Etges
T: +49(0)221 347 0
F: +49(0)221 347 1250
documentation@leybold.com

Cologne, May 11, 2018

Cologne, May 11, 2018



Andries Desiron
VP Engineering
Industrial Vacuum

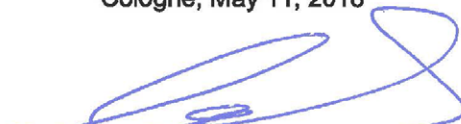

i.V. Martin Laerbusch
Head of Production Systems
Cologne Product Company

Document No.: 300648821-002-A1

EC Declaration of Incorporation

(Translation of original Declaration of Incorporation)

The manufacturer: Leybold GmbH
Bonner Strasse 498
D-50968 Köln
Germany

herewith declares that the following product:

Product designation: Oil Diffusion Pumps

Type designation: DIP 3000, DIP 8000, DIP 12000, DIP 20000, DIP 30000, DIP 50000

complies with the following fundamental requirements of the **Machinery Directive (2006/42/EC)**:
Annex I, Paragraph 1.1.2, 1.1.3, 1.1.5, 1.2.1, 1.2.3, 1.2.4.1, 1.2.4.2, 1.2.6, 1.3.1, 1.3.2, 1.3.3, 1.3.4, 1.3.7,
1.5.1, 1.5.2, 1.5.4, 1.5.5, 1.5.13, 1.6.1 and 1.7.1

The safety objectives of the Low Voltage Directive 2014/35/EU were complied with in accordance with
Appendix 1 No. 1.5.1 of Machinery Directive 2006/42/EC.

The following harmonised standards have been applied:

EN 1012-2:1996+A1:2009 Compressors and vacuum pumps - Safety requirements
Part 2: Vacuum pumps

EN 60204-1:2006 Safety of machinery - Electrical equipment of machines
Part1: General requirements

The incomplete machine may only be put into operation after it has been determined that the machine into
which the incomplete machine shall be installed complies with the regulations laid down in the EC
Machinery Directive (2006/42/EC).

The manufacturer commits himself to make the special documentation on the incomplete machine
electronically available to national authorities upon request. The special engineering documentation
belonging to the machine was compiled in accordance with Annex VII Part B.

Documentation officer: Leybold GmbH, Bonner Straße 498, D-50968 Köln
Herbert Etges
T: +49(0)221 347 0
F: +49(0)221 347 1250
documentation@leybold.com

Cologne, May 11, 2018



Andries Desiron
VP Engineering
Industrial Vacuum

Cologne, May 11, 2018



i.V. Martin Laerbusch
Head of Production Systems
Cologne Product Company

Document No.: 300648821-002-A1



Pioneering products. Passionately applied.

Leybold GmbH
Bonner Strasse 498
50968 Cologne
GERMANY
T: +49-(0)221-347-0
info@leybold.com
www.leybold.com