

9700A Compressor Installation, Operation, and Maintenance Instructions

The information in this document is believed to be accurate and reliable. However, Helix Technology Corporation, cannot accept any financial or other responsibilities that may result from the use of this information. No warranties are granted or extended by this document.

Helix Technology Corporation reserves the right to change any or all information contained herein without prior written notice. Revisions may be issued at the time of such changes and/or deletions.

Any duplication of this manual or any of its parts without expressed written permission from Helix Technology Corporation is strictly prohibited.

Any correspondence regarding this document should be forwarded to:

Helix Technology Corporation
Mansfield Corporate Center
Nine Hampshire Street
Mansfield, Massachusetts 02048-9171 U.S.A.

Telephone: (508) 337-5000

FAX: (508) 337-5464

The following Helix Technology Corporation trademarks and service marks may appear in this document:

Conductron®	Convectron®	Cryodyne®	Cryogem®
Cryogenerator®	Cryo-Torr®	CTI-Cryogenics®	FastRegen™
GOLDLink®	Granville-Phillips®	GUTS®	Helix®
Helix Technology. Your Vacuum Connection SM	Micro-Ion®	Mini-Convectron®	Mini-Ion™
On-Board®	RetroEase®	RetroFast®	Stabil-1®
Stabil-Ion®	ThinLine™	TurboPlus®	TrueBlue SM
Vacuum Assurance SM			

All other trademarks or registered trademarks are the property of their respective holders.

Table of Contents

Figures

Tables

Compressor Safety

Section 1 - 9700A Compressor Description

General	1-1
Compressor Configurations	1-1
System Documentation	1-1
CTI-CRYOGENICS Helium Refrigeration System	1-1
Specifications	1-4
Dimensions	1-4
Weight	1-5
Electrical	1-5
Cooling Water	1-6
General	1-9
Component Description	1-10
System Circuit Breaker	1-11
Power ON Indicator	1-11
Elapsed Time Meter	1-11
Control Circuit Breaker	1-11
Power Cable Connector	1-11
Gas Charge Fitting	1-11
Helium Pressure Gauge	1-12
Helium Return Coupling	1-12
Cooling Water IN	1-12
Cooling Water OUT	1-12
Casters	1-12
Helium Supply Coupling	1-13
Access Panel	1-13
Compressor Remote Connector	1-13
Cryopump Electrical Outlet	1-14
Multiple On-Board Cryopump Connections	1-14
Multiple Cryo-Torr Cryopump Connections	1-15

Section 2 - Unpacking and Inspection

Introduction	2-1
--------------------	-----

Shipping Carton Inspection	2-1
Removal from Shipping Carton	2-1
Using the Ramp	2-1
Using a Lifting Device	2-3
Compressor Inspection	2-5
Compressor	2-5
Helium Static Pressure Verification	2-5
Shipping Carton Contents	2-5

Section 3 - Installation

Introduction	3-1
Supply and Return Water Line Connections	3-3
Hard Water Lines	3-3
Flexible Water Lines	3-3
Electrical Connections	3-4
Power Cable Preparation	3-4
Phase Check	3-6
Connecting/Disconnecting Helium Flex Lines	3-7
Connecting	3-7
Disconnecting	3-8
Single On-Board Pump Connections	3-8
Single Cryo-Torr Cryopump Connections	3-9
Multiple On-Board Pump Connections	3-11
Helium Line Connections	3-11
Power Cable Connections	3-12
Multiple Cryo-Torr Cryopump Connections	3-13
Helium Line Connections	3-13
Power Cable Connections	3-13

Section 4 - Operation

Adjusting System Helium Pressure	4-1
Static Helium System Pressure Verification	4-1
Compressor Operation	4-2
Replacement of Helium Circuit Components	4-3

Section 5 - Maintenance

Scheduled Maintenance	5-1
Suggested Maintenance Equipment	5-1
Adsorber Replacement	5-2
Adjusting System Helium Pressure	5-4
Reducing Helium Pressure	5-4
Increasing Helium Pressure	5-5
Adding Helium	5-5

Appendix A - Customer Support Information

Customer Support Center Locations A-1
Guaranteed Up-Time Support (GUTS) A-1
 Product Information A-1
E-mail A-1

Appendix B - Flow Diagram

Appendix C - Troubleshooting Procedures

Troubleshooting the Compressor C-1
Technical Inquiries C-1

Appendix D - Schematic

Introduction D-1

Index

Figures

Figure 1-1: 9700A Compressor	1-3
Figure 1-2: 9700A Compressor Dimensions	1-4
Figure 1-3: Water Flow Rate versus Pressure Drop	1-7
Figure 1-4: 9700A Cooling Water Flow Rate versus Inlet Temperature	1-8
Figure 1-5: 9700A Compressor Rear View Component Locations.	1-10
Figure 1-6: 9700A Compressor Connected to Multiple On-Board Waterpumps . .	1-15
Figure 1-7: 9700A Compressor Connected to Multiple Cryo-Torr Cryopumps . .	1-16
Figure 2-1: Using the Shipping Carton Ramp	2-2
Figure 2-2: Attaching Eye Bolts and Lifting Slings to the 9700A Compressor . . .	2-4
Figure 3-1: 9700A Compressor Installation Flowchart	3-2
Figure 3-2: 9700A Compressor Circuit Breaker Terminals	3-5
Figure 3-3: Connecting/Disconnecting Helium Flex Line Self Sealing Couplings. .	3-8
Figure 3-4: Single On-Board Pump Connections	3-9
Figure 3-5: Single Cryo-Torr Cryopump Installation	3-10
Figure 3-6: Connecting Multiple On-Board Pumps to the 9700A Compressor . .	3-12
Figure 3-7: Multiple Cryo-Torr Cryopump Installation	3-14
Figure 5-1: Disconnecting Self Sealing Couplings	5-2
Figure 5-2: Adsorber Location in the 9700A Compressor (Rear Panel Removed). .	5-3
Figure 5-3: Helium Pressure Control Components	5-4
Figure B-1: 9700A Compressor Flow Diagram	B-1
Figure D-1: 9700A Compressor (Low Voltage)	D-5
Figure D-2: 9700A Compressor (Low Voltage) with GFI	D-6

Tables

Table 1-1: Compressor Weight	1-5
Table 1-2: Electrical Input Specifications	1-5
Table 1-3: Cooling Water Specifications	1-6
Table 1-4: General Compressor Operating Specifications	1-9
Table 1-5: Compressor Remote Connector Pin Assignments	1-13
Table 1-6: Cryopump Power Connector Pin Assignments	1-14
Table 4-1: 9700A Compressor Helium Static Charge	4-1
Table 5-1: Suggested Maintenance Equipment	5-1
Table C-1: Compressor Troubleshooting Procedures	C-2
Table D-1: Basic Control Assembly Legend	D-1
Table D-2: On-Board/Cryo Electrical Module Legend	D-2
Table D-3: On-Board Output Module P/N 8135148G001 Legend	D-3

Compressor Safety

Introduction

All CTI-Cryogenics compressor products are designed to provide extremely safe and dependable operation when properly used. You must observe safety precautions during normal operation and when servicing vacuum systems.

NOTE: Read this manual and follow the safety guidelines in this chapter before installing, operating, or servicing CTI-Cryogenics products.

Safety Symbols

The safety symbols in this manual conform to ISO 3864 and ANSI Z535 standards. Table S-1 describes the kinds of symbols used in this manual.

Table S-1: Safety Symbols

Symbol Type	Example	Description
Warning		Identifies the hazard; for example, electric shock

Signal Word Description



This Caution indicates a potentially hazardous situation or unsafe practice which, if not avoided, may result in **minor or moderate personal injury or equipment damage**. This Caution is highlighted in yellow

This caution indicates a situation or unsafe practice which, if not avoided, may result in **equipment damage**. This Caution is not color highlighted.



A Warning indicates a potentially hazardous situation which, if not avoided, could result in **serious injury or death**. A Warning is highlighted in orange.

Compressor Cautions and Warnings

You must observe the following safety precautions when installing, operating, and maintaining CTI-Cryogenics compressor equipment. If you have any doubts on using this equipment, refer to Appendix A, “*Customer Support*” and call your local Customer Support Center for assistance.

High Voltage

	<div style="background-color: orange; color: black; padding: 5px; display: inline-block;">⚠ WARNING</div> <p>High Voltage</p> <p>High voltage electric shock can cause severe injury or loss of life. Follow all local, state, and national codes when working with high voltage equipment.</p>
---	---

Take the following precautions to prevent high voltage risks:



1. Follow all local high voltage safety precautions to reduce the possibility of electrical shock.
2. Make sure that all electrical power is OFF before proceeding with any procedure that requires access to the interior of the housing.
3. Disconnect the power by setting the switch at the power entry module to the OFF position or removing the power cord from the power entry module.

Equipment Could Start

	<div style="background-color: yellow; color: black; padding: 5px; display: inline-block;">⚠ CAUTION</div> <p>Equipment Could Start</p> <p>The Compressor might start automatically when the remote start feature is used.</p>
---	---

1. Lock out and tag out the compressor to prevent a remote start before attempting service.

Burn Hazard

	<p data-bbox="773 359 1190 443"> WARNING</p> <p data-bbox="578 464 1149 531">Burn Hazard Compressor pump can be hot after extended use.</p>
---	---

1. Allow the compressor pump to cool before servicing.

Section 1 - 9700A Compressor Description

General

This manual provides the information required to install, operate, and maintain the CTI-CRYOGENICS 9700A Compressor.

NOTE: All personnel with installation, operation, and maintenance responsibilities should become familiar with the contents of both the 9700A Compressor Installation, Operation, Maintenance, and appropriate cryopump manuals to ensure safe, high quality, and reliable system performance.



CAUTION

Refer to Appendix A - Customer Support Information to contact the local Customer Support Center for information on connecting 9700A Compressors to a manifold with other CTI-CRYOGENICS compressors.

Compressor Configurations

The 9700A Compressor supports either On-Board or Cryo-Torr Cryopumps. For multiple cryopump installations, an On-Board Splitter Box or Cryo-Torr Interface can be used for cold head power distribution that reduces total cable requirements as shown in [Figure 1-6](#) and [Figure 1-7](#).

System Documentation

The manuals for a *system* cover two basic components: the cryopump and the Compressor. A manual is shipped with each system component to provide information for installation and operation of that component. A loose-leaf binder with index tab separators is also provided so you can compile a complete set of tabulated manuals.

CTI-CRYOGENICS Helium Refrigeration System

The operation of CTI-CRYOGENICS' cryopumps is based upon a closed loop helium expansion cycle. The *system* is made up of two major

components: the cryopump, which contains the cold head, and the helium Compressor which compresses the helium gas.

Refrigeration is produced in the cryopump cold head through periodic expansion of high pressure helium in a regenerative process. The high pressure helium is provided by the Compressor. Low pressure helium returning from the cold head is compressed into the necessary high pressure to be returned to the cold head. The energy required to compress the helium is rejected as heat through the cooling water.

High pressure room temperature helium is transferred to the cold head through the supply lines. After expansion, low pressure helium is returned to the Compressor (at or near room temperature) to repeat the cycle in a closed loop fashion. Large separation distances can be accommodated between the Compressor and the cryopump.

In the Compressor, helium is compressed using a highly reliable oil lubricated commercial Compressor. Helium purification takes place via several stages of oil removal. The final stage of purification is performed with a replaceable adsorber cartridge. In order to maintain peak efficiency, the adsorber must be replaced every three years. The 9700A Compressor is shown in [Figure 1-1](#).



Figure 1-1: 9700A Compressor

Specifications

Dimensions

The dimensions of the 9700A Compressor are shown in [Figure 1-2](#).

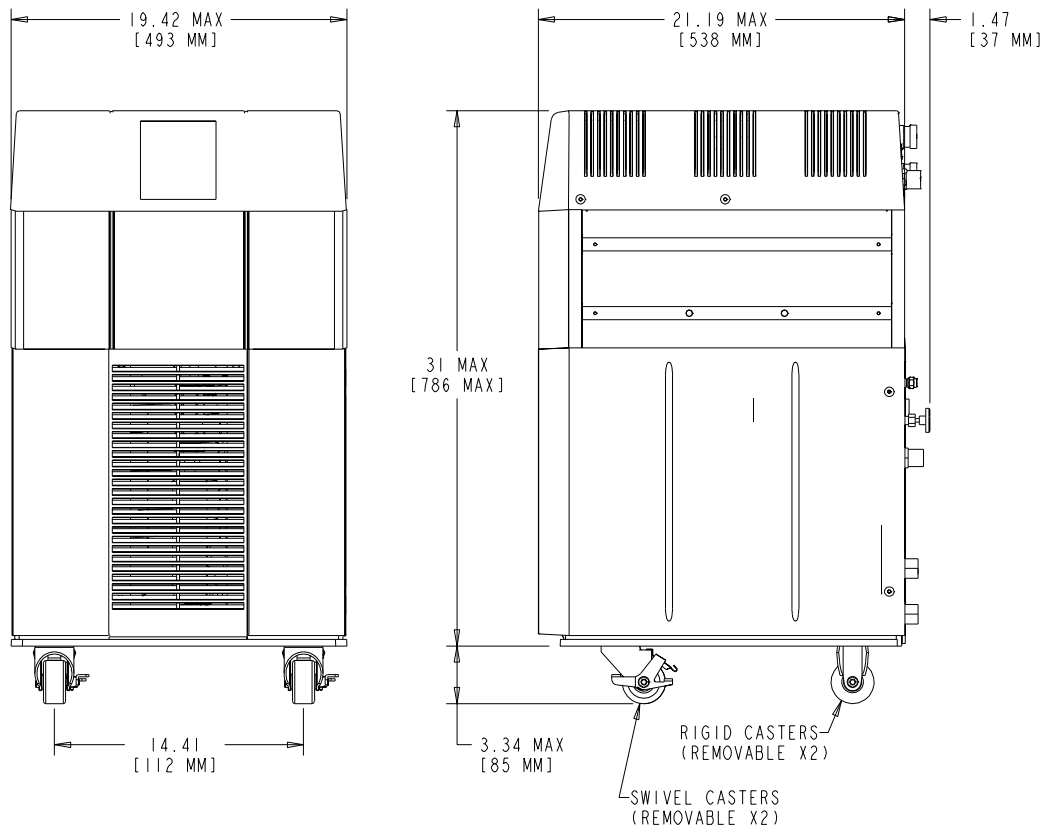

Figure 1-2: 9700A Compressor Dimensions



CAUTION

Do not place a weight greater than 75 lbs. (34Kg) on top of the Compressor.

Weight

The weight of the Compressor is listed in [Table 1-1](#).

Table 1-1: Compressor Weight

Weight lbs./kg
350/159

Electrical

The electrical specifications of the Compressor are listed in [Table 1-2](#).

Table 1-2: Electrical Input Specifications

Parameter	60 Hz	50 Hz
Operating Voltage Range	190 - 253 VAC	180 - 253 VAC
Phase	3	3
Nominal Input Power	5.8 KW	5.3 KW
Nominal Power Factor	0.85	0.85
Rated FL/LR ¹ Current	23/85	22/80
Minimum Electrical Service	30 Amps	30 Amps

1. Full Load/Locked Rotor

Cooling Water

The water used to cool the Compressor must meet the specifications shown in [Table 1-3](#) for proper system operation.

Table 1-3: Cooling Water Specifications

Parameter	Value
Maximum Inlet Temperature ¹	90°F (32°C)
Minimum Inlet Temperature	50°F (10°C)
Flow Rate	3.0 ±1.0 gpm (11.4 ± 3.8 lpm)
Pressure Drop (inlet-to-outlet)	See Figure 1-3
Maximum Inlet Pressure	100 psi (6.9 bars)
Alkalinity	6.0 - 8.0 pH
Calcium Carbonate	< 75 ppm

1. See [Figure 1-4](#) for minimum recommended water flow above 80° F inlet temperature. Water conditioning may be required for applications not meeting these requirements.

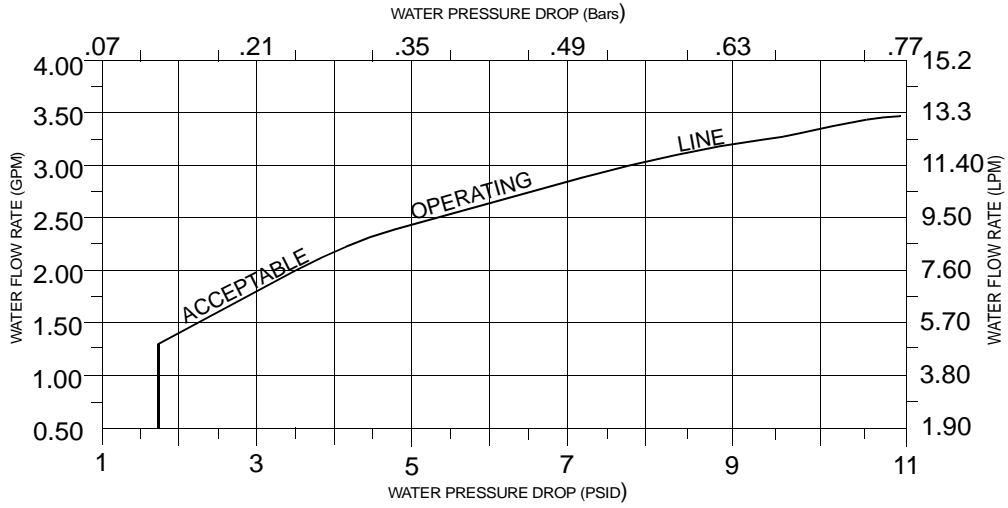

NOTE: Figure 1-3 defines the water flow rate through the Compressor as a function of the pressure drop from water inlet to water outlet. You must provide the correct pressure drop in your water supply system to ensure that the water flow condition meets the requirements specified in [Table 1-3](#).

Figure 1-3: Water Flow Rate versus Pressure Drop

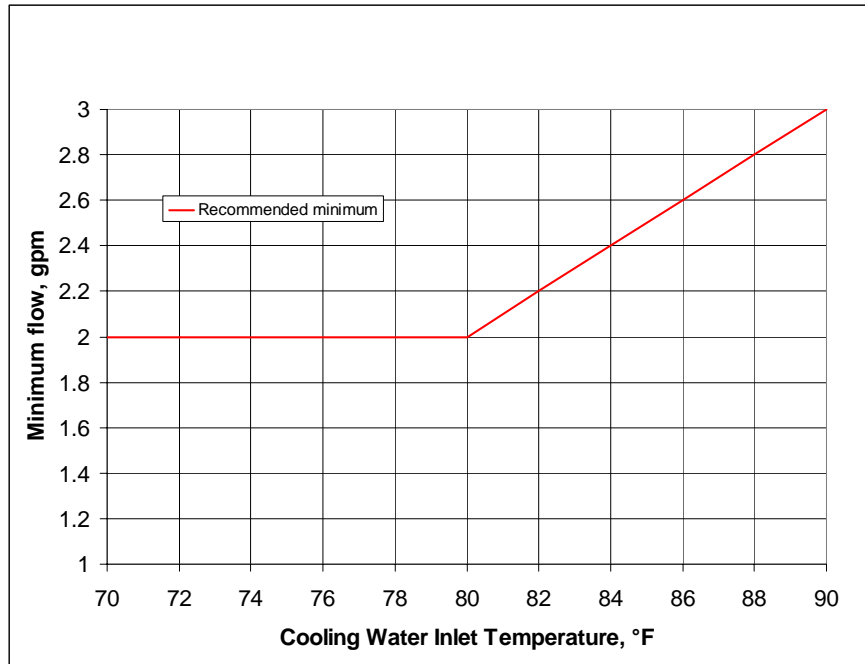

NOTE: Figure 1-4 shows that cooling water flow rate must be increased if the inlet temperature of the cooling water is above 80° F.

Figure 1-4: 9700A Cooling Water Flow Rate versus Inlet Temperature

General

Table 1-4 provides general Compressor operating specifications.

Table 1-4: General Compressor Operating Specifications

Specification	Description
Part Number 8135924G001 8135924G002 8135924G003 8135924G004	2-phase output with PSI gauge 2-phase output with kPa gauge and GFI 3-phase output with PSI gauge 3-phase output with kPa gauge and GFI
Input Power Cable (Customer Supplied)	600 VAC 10 Gauge, 3 conductor wire with ground Must conform to local electrical codes
Nominal Helium Pressure	Refer to Table 4-1 .
Ambient Operating Temperature Range	50 - 100° F (10 - 38° C)
Interface Gas Supply Connector Gas Return Connector Remote Control Receptacle	Cryopump Power Receptacle mates with the CTI-CRYOGENICS supplied cryopump power cable for single pump use. Mates with remote junction box power cable for multiple cryopump use. 1/2 in. Aeroquip self-sealing coupling 1/2 in. Aeroquip self-sealing coupling 24VAC, 2.7A inductive mates with P5 connector P/N MS3106A ¹
Adsorber Service Schedule	3 years

1. Supplied by CTI-CRYOGENICS

NOTE: The 9700A Compressor is designed for continuous operation and should remain ON when the cryopumps are in a regeneration cycle.

Component Description

The components of the 9700A Compressor that are accessible from the rear panel are shown in Figure 1-5 and described in the following paragraphs.

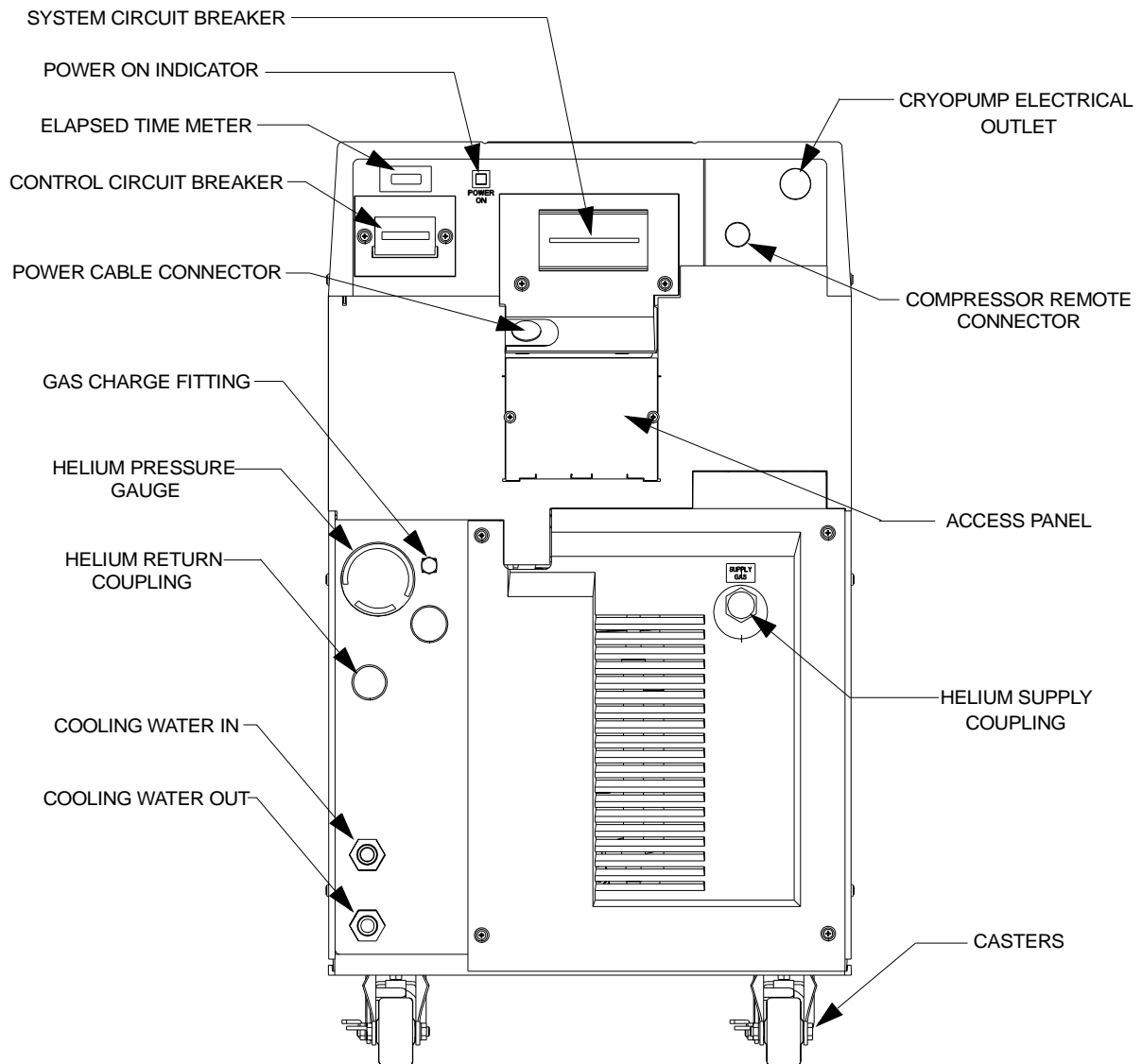

Figure 1-5: 9700A Compressor Rear View Component Locations

System Circuit Breaker

The System Circuit Breaker protects main input power to the Compressor pump and module. The circuit breaker positions are labeled ON (1), which is in the UP position, and OFF (0), which is in the DOWN position.

NOTE: The phase monitor within the Compressor will cause the system circuit breaker to open when input power phases are incorrect.

Power ON Indicator

The Power On Indicator illuminates when the system circuit breaker is placed in the ON position. The Compressor pump is energized when the power indicator is illuminated and the elapsed time meter records system operation time.

Elapsed Time Meter

The Elapsed Time Meter records the number of Compressor operating hours. Since the meter is digital, it is not illuminated unless the system circuit breaker is in the ON position and power is connected to the Compressor. The Elapsed Time Meter maintains the correct accumulated operating hours while system power is turned OFF.

NOTE: The meter cannot be reset.

Control Circuit Breaker

The Control Circuit Breaker provides current overload protection for all internal components of the Compressor except the Compressor motor. The Compressor motor is protected by a separate overload protector. The Control Circuit Breaker opens automatically and must be reset manually.

Power Cable Connector

The Power Cable Connector is used to connect your power cable to the Compressor. Refer to **Section 3 - Installation** for information on power cable installation.

Gas Charge Fitting

The Gas Charge Fitting is used to connect a 99.999% pure helium supply to the Compressor when helium charging is required. The fitting has a 45° flare and 7/16 in. x 20 threads/inch.

Refer to Section 5 - Maintenance for information on adding helium to the Compressor.

Helium Pressure Gauge

The Helium Pressure Gauge indicates system static helium charge pressure when the Compressor and cryopumps are OFF and Compressor suction or inlet pressure when the Compressor is ON. Refer to [Table 4-1](#) for the appropriate static helium charge pressure.

Helium Return Coupling

The Return Gas Coupling returns the helium, which has been cycled through the cryopump, back to the Compressor. Refer to

CTI-CRYOGENICS Helium Refrigeration System within this section for more information.

Cooling Water IN

The Cooling Water IN connector provides water to the Compressor from your facility to cool the Compressor during operation. The connector thread size is a 1/2 in. female pipe thread. The water must meet the specifications outlined in [Table 1-3](#). Refer to Section 3 - Installation for more information on cooling water connections.

Cooling Water OUT

The Cooling Water OUT connector returns the water that has been used to cool the Compressor to your facility. The connector thread size is a 1/2 in. female pipe thread. Refer to Section 3 - Installation for more information on cooling water connections.

Casters

The Casters allow the 9700A Compressor to moved.



CAUTION

The Casters a should be in the locked position after the 9700A Compressor has been installed to prevent compressor movement.

Helium Supply Coupling

The Supply Gas Coupling provides a connection for high pressure compressed helium to the cryopump cold head. Refer to

[CTI-CRYOGENICS Helium Refrigeration System](#) within this section for more information.

Access Panel

The Access Panel protects the Compressor Power Cable connections.



WARNING

The Access Panel should not be removed from the 9700A Compressor until the power source has been turned OFF.

Compressor Remote Connector

The Compressor Remote Connector is a two-pin connector that can be used in conjunction with the On-Board setpoint relays, relays in the Cryo-Torr Interface, or a signal from the vacuum system to turn the Compressor ON or OFF. Refer to [Table 1-5](#) for connector pin identification. Switching contacts must be rated at 24VDC, 2.7A inductive.

NOTE: The Compressor is shipped with a mating plug which must remain installed in the Compressor Remote Connector to ensure Compressor operation when the Compressor remote feature is not being used.

Table 1-5: Compressor Remote Connector Pin Assignments

Identifier	Function
A and B	Compressor Remote Control - Make = ON, Break = OFF

Cryopump Electrical Outlet

The Cryopump Electrical Outlet provides power to a single On-Board or Cryo-Torr Cryopump, an On-Board Splitter Box, or a Cryo-Torr Interface. The Compressor requires the use of an On-Board Splitter Box or Cryo-Torr Interface for multiple cryopump system connections. Refer to [Table 1-6](#) for connector pin identification. Refer to **Multiple On-Board Cryopump Connections** or **Multiple Cryo-Torr Cryopump Connections** in this section for more information.

Table 1-6: Cryopump Power Connector Pin Assignments

Identifier	Function
A and B	Heater Power - 208 VAC nominal
C	Center tap for D and E
D and E	24 VCT @ 4.6 Amps
F-G and G-H	Cold Head Voltage Output 130-160 VAC @ 4.5 Amps
J	Chassis Ground
K	Not Used

Multiple On-Board Cryopump Connections

The On-Board Splitter Box permits the connection of multiple On-Board Cryopumps or Waterpumps to one 9700A Compressor as shown in [Figure 1-6](#). The actual number of On-Board Pumps that can be connected to the 9700A Compressor depends upon the process application and the type of On-Board pumps required.

***NOTE:** Refer to Appendix A - Customer Support Information to consult your local CTI-CRYOGENICS Customer Support Center for information on specific compressor/pump applications.*

Refer to Section 3 - Installation for more information on connecting single or multiple On-Board Cryopumps or Waterpumps to the 9700A Compressor.

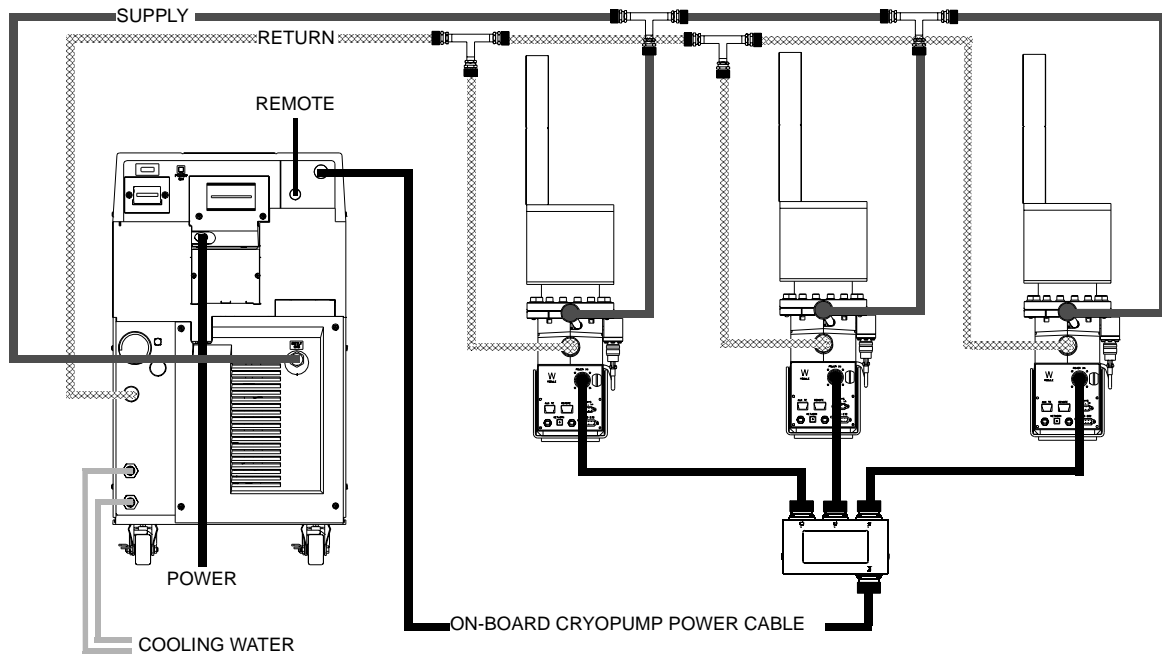

Figure 1-6: 9700A Compressor Connected to Multiple On-Board Waterpumps

Multiple Cryo-Torr Cryopump Connections

The Cryo-Torr Interface permits the connection of multiple Cryo-Torr Cryopumps to one 9700A Compressor as shown in [Figure 1-7](#). The actual number of Cryo-Torr Pumps that can be connected to the 9700A Compressor depends upon the process application and the type of Cryo-Torr pumps required.

***NOTE:** Refer to Appendix A - Customer Support Information to consult your local CTI-CRYOGENICS Customer Support Center for information on specific compressor/cryopump applications.*

Refer to Section 3 - Installation for more information on connecting single or multiple Cryo-Torr Cryopumps to the 9700A Compressor.

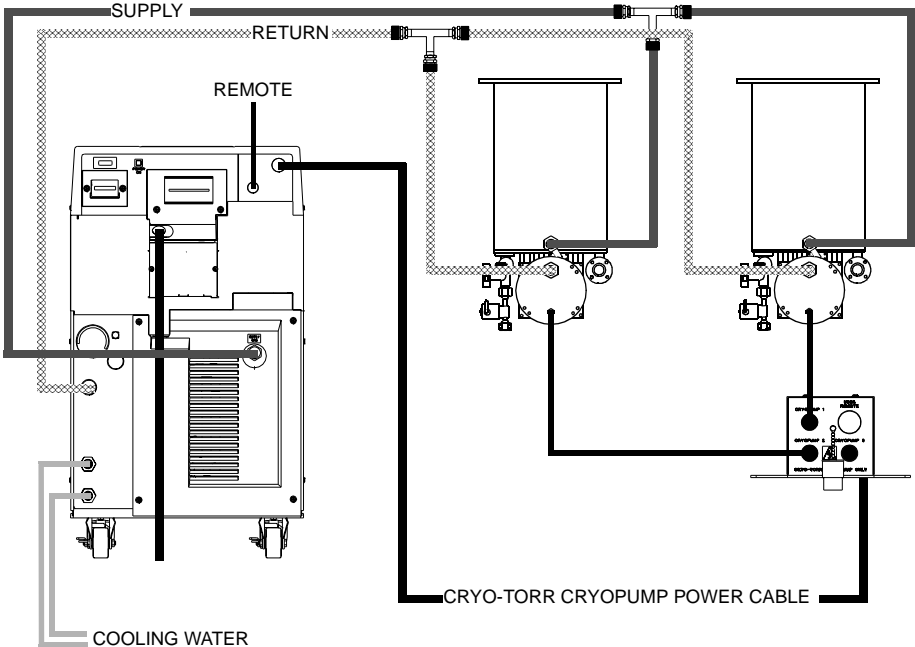

Figure 1-7: 9700A Compressor Connected to Multiple Cryo-Torr Cryopumps

Section 2 - Unpacking and Inspection

Introduction

The 9700A Compressor is shipped in a shipping carton incorporating a ramp system which makes removing the Compressor from the carton safe and easy.

Shipping Carton Inspection

Inspect the exterior of the shipping carton for visible signs of damage before opening the shipping carton. Report any damage to the shipping company at once.

Removal from Shipping Carton

There are two methods of removing the 9700A Compressor from the shipping carton: using the ramp within the carton, or using a lifting device.

Using the Ramp

1. Cut the two straps on the exterior of the shipping pallet.
2. Lift the cardboard carton straight up and remove it from the pallet.
3. Cut the tape which holds the ramp in the vertical position.
4. Swing the ramp down until the end touches the floor as shown in Figure 2-1.
5. Remove any excess shipping material from around the Compressor.



WARNING

Be certain to maintain control over the movement of the Compressor as it rolls down the ramp. Injury to personnel may result if the Compressor is allowed to roll freely down the ramp.

6. Carefully roll the Compressor down the ramp and onto the floor as shown in Figure 2-1.

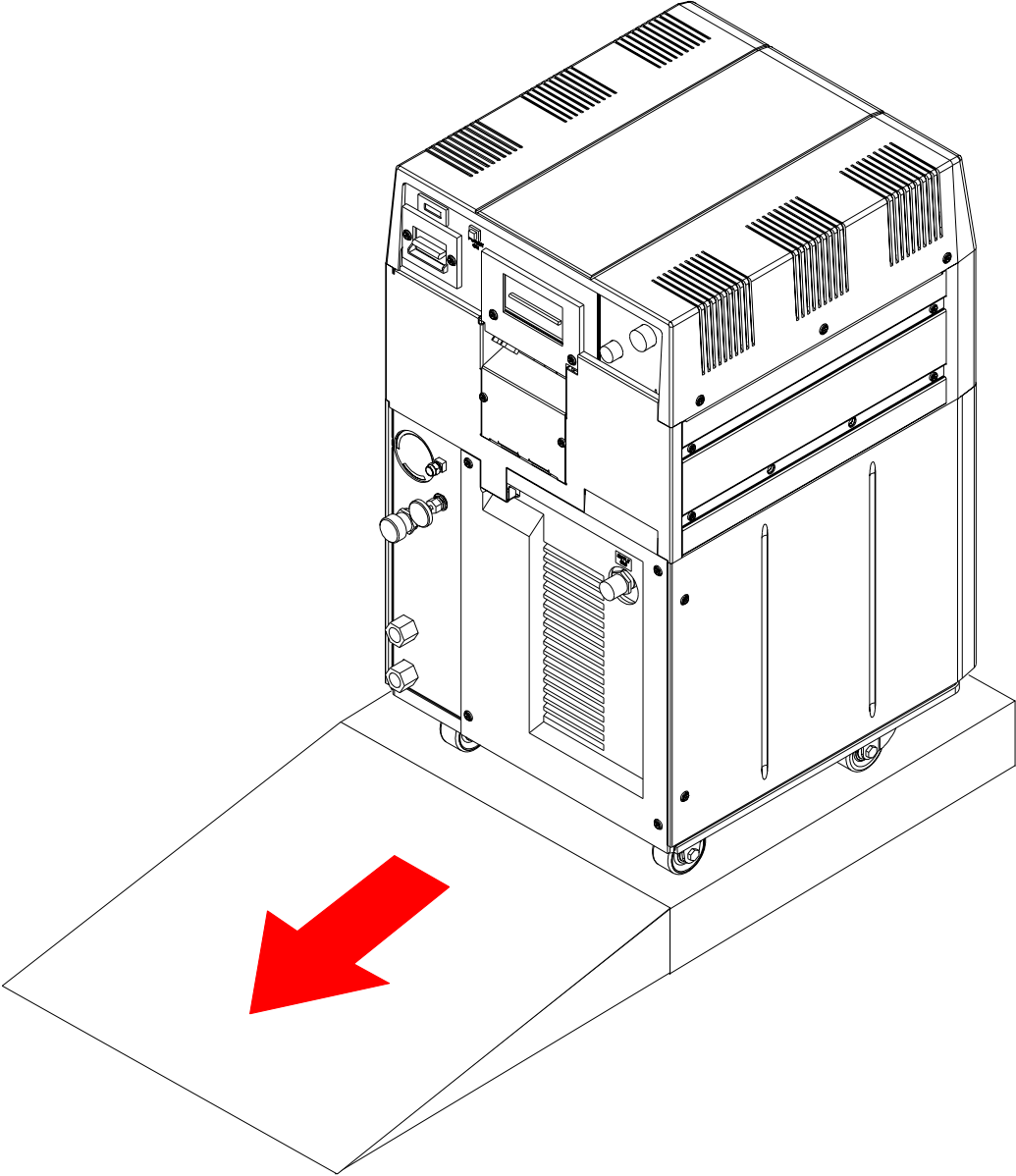

Figure 2-1: Using the Shipping Carton Ramp

Using a Lifting Device



CAUTION

The lifting device must be capable of lifting 350 pounds (159 kg).

1. Cut the two straps on the exterior of the shipping pallet.
2. Lift the cardboard carton straight up and remove it from the pallet.
3. Cut the tape which holds the ramp in the vertical position.
4. Remove the ramp from the shipping carton.
5. Remove any excess shipping material from around the Compressor.

6. Install the four customer supplied 3/8 inch x 16 eye bolts into the holes on each side of the 9700A Compressor as shown in Figure 2-2.

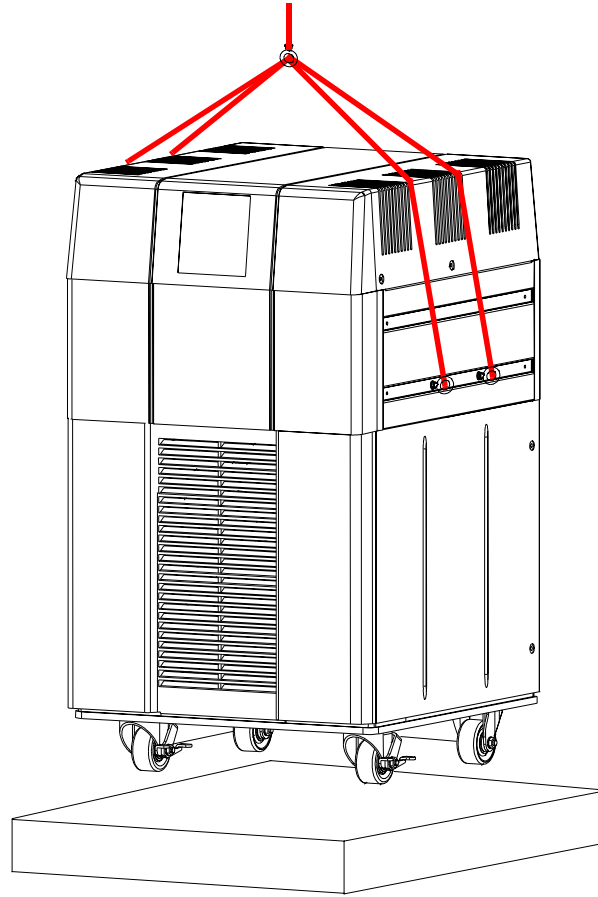

Figure 2-2: Attaching Eye Bolts and Lifting Slings to the 9700A Compressor



CAUTION

The lifting sling minimum length must be 48 inches to prevent damaging the sides of the 9700A Compressor when being lifted from the shipping carton.

7. Attach 1 lifting sling (minimum 48 inches in length) to each eye bolt as shown in Figure 2-2.
8. Attach the lifting slings to the lifting device and lift the 9700A Compressor off the shipping carton.
9. Slide the shipping carton out from under the 9700A Compressor.
10. Lower the 9700A Compressor onto its casters and remove the lifting slings and eyebolts.

Compressor Inspection

Inspect the Compressor for visible signs of damage as indicated in the following paragraphs.

Compressor

Inspect the exterior of the Compressor for visible signs of damage, evidence of an oil leak, and check the Helium Pressure Gauge for proper helium pressure. Report any damage to the shipping company at once.

Helium Static Pressure Verification

Refer to Section 4 - Operation for more information on the static helium charge pressure of the 9700A Compressor.

Shipping Carton Contents

The shipping carton should contain the following items:

- Compressor
- Two barbed fittings for flexible water lines
- Installation, Operation, and Maintenance manual
- Compressor remote start connector and strain relief

Section 3 - Installation

Introduction

Section 3 provides you with the information required to install the 9700A Compressor and connect it to single or multiple On-Board or Cryo-Torr Cryopump configurations.

Figure 3-1 highlights the major tasks for 9700A Compressor installation and refers to the appropriate installation procedures within this section.

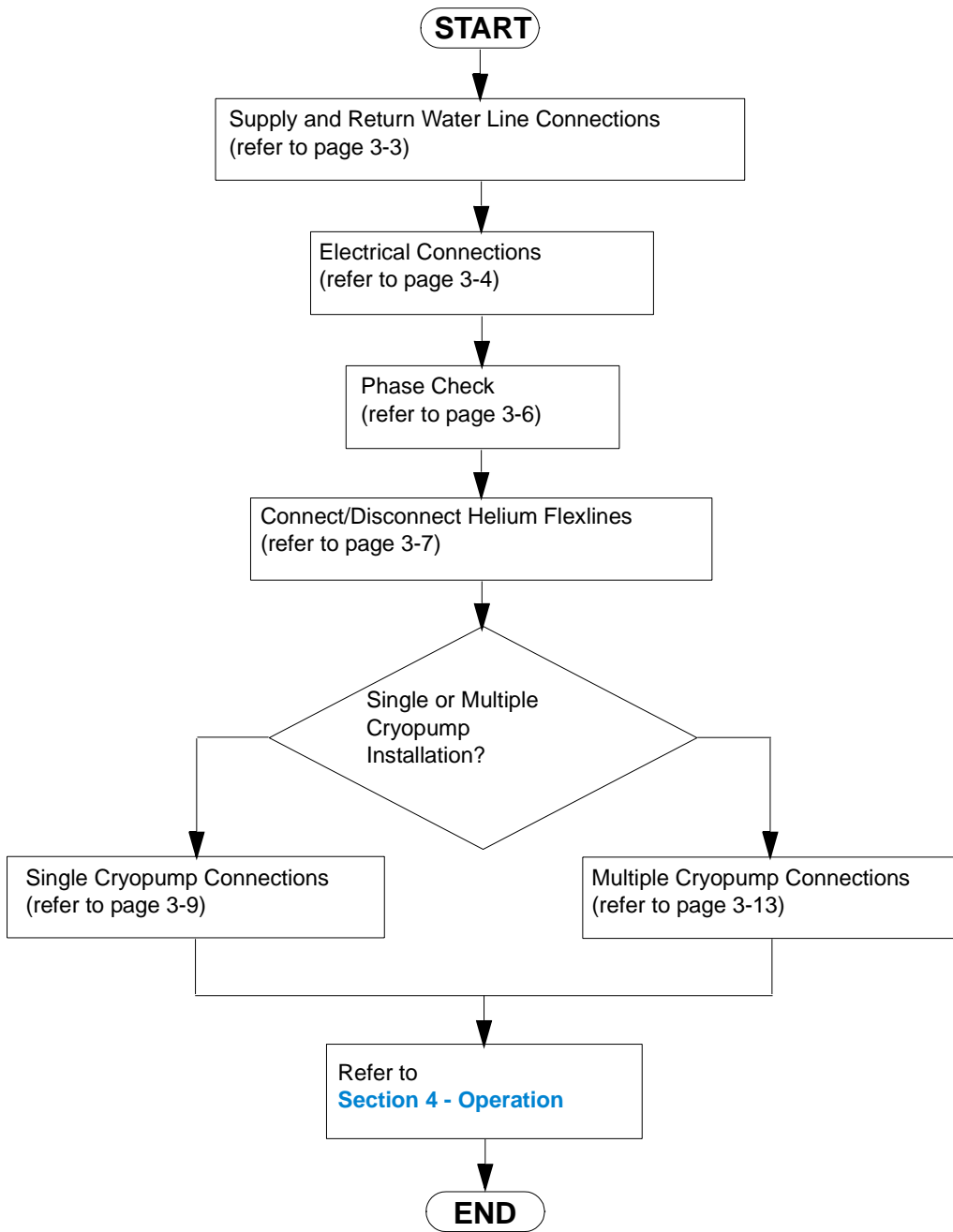

Figure 3-1: 9700A Compressor Installation Flowchart

Supply and Return Water Line Connections

NOTE: The water used for cooling the 9700A Compressor must meet the specifications outlined in Section 1 - 9700A Compressor Description.

Hard Water Lines

1. Apply a light coating of standard plumbing thread sealant to the hard line pipe threads.
2. Install the Supply hard line into the INPUT connection on the rear panel of the 9700A Compressor. Tighten the fitting by hand.
3. Install the Return hard line into the OUTPUT connection on the rear panel of the 9700A Compressor. Tighten the fitting by hand.



CAUTION

Do not overtighten the ferrules. Damage to the input and output connector threads may occur.

4. Using a wrench, tighten the fittings.
5. Allow water to flow and check for leaks at the rear of the 9700A Compressor.

Flexible Water Lines

1. Apply a light coating of standard plumbing thread sealant to the barbed fitting threads.
2. Install the barbed fittings into the INPUT and OUTPUT connections on the rear panel of the 9700A Compressor.



CAUTION

Do not overtighten the barbed fittings. Damage to the INPUT and OUTPUT connector threads may occur.

3. Using a wrench, tighten the barbed fittings.
4. Connect the Supply flexible water line to the INPUT barbed fitting and secure with a hose clamp.

5. Connect the Return flexible water line to the OUTPUT barbed fitting and secure with a hose clamp.
6. Allow water to flow and check for leaks at the rear of the 9700A Compressor.

Electrical Connections



CAUTION

The following procedures provide information for making all three phase (200 - 230 VAC) electrical connections to the 9700A Compressor.



WARNING

Helium flexlines are part of the protective earth ground (bonding) from compressor to cryopumps. Make sure the flexlines have been installed before operating the system.

Power Cable Preparation



WARNING

The 9700A Compressor power cord must be installed by qualified personnel in accordance with the National Electrical Code, ANSI/NFPA 70-1987, as well as all local codes. The cable used for making the 9700A Compressor power cable must be a 10 gauge, 3 conductor cable with ground rated at 600 VAC. The power cord installation shall include the installation of a readily accessible disconnect/device into the fixed wiring supplying power. Follow all local high voltage safety precautions when performing this procedure to reduce the possibility of electrical shock. Make sure all electrical power is OFF before proceeding with this procedure.

1. Cut a 10 AWG (6.00 mm²), 3 conductor cable with ground to an appropriate length.
2. Strip the cable jacket back 4 in. (101.6 mm).
3. Strip the insulation back 3/8 in. (9.3 mm) on each individual conductor.

4. Install a #10 ring tongue terminal on the end of each conductor using the appropriate size double crimping tool.
5. Remove the access panel as shown in Figure NOTE:.
6. Remove the circuit breaker terminal cover as shown in Figure NOTE:.
7. Install the cable into the 9700A Compressor through the cable strain relief.
8. Remove the 10-32 nut and install the grounding wire on the ground stud. Install the nut and tighten to 18 in.-lbs (0.21m-kg).

NOTE: Use a slotted screwdriver which is capable of holding a screw when performing steps 9 and 10 Remove the screws from the 9700A Compressor circuit breaker terminals X, Y, and Z as shown in Figure NOTE:..

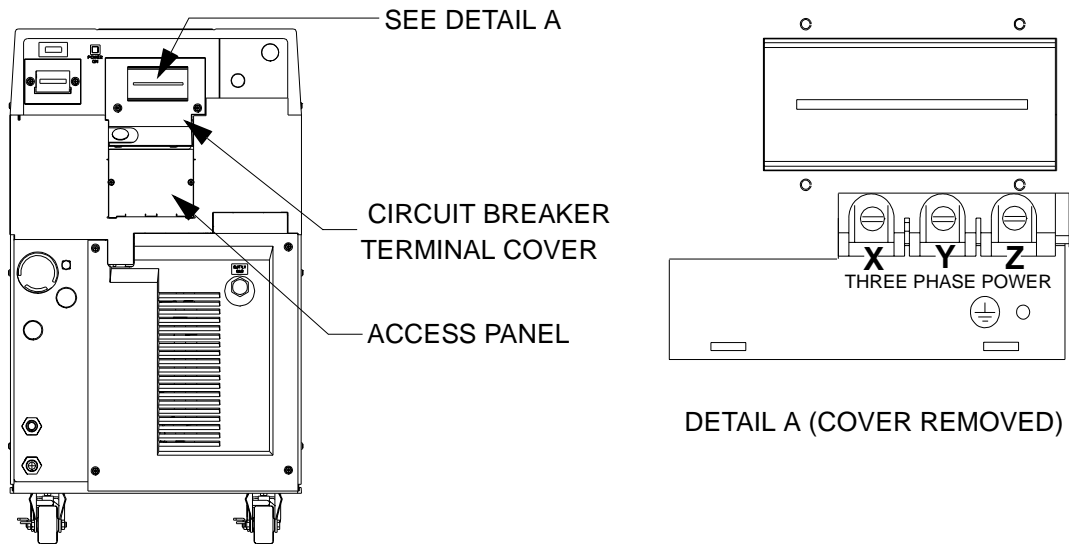

Figure 3-2: 9700A Compressor Circuit Breaker Terminals

NOTE: The phase order in which the conductor terminal lugs are connected to circuit breaker terminals X, Y, and Z will be determined during the Phase Check Procedure.

NOTE: For installation where one of the three phase legs is at or near ground potential, connect that leg to terminal Y on the 9700A Compressor as shown in Figure NOTE:.

9. Install the conductor terminal lugs to the circuit breaker terminals X, Y, and Z as shown in Figure NOTE:.
10. Torque the screws to 12 in.-lbs (0.14m-kg).

11. Allow enough cable to stay in the electrical enclosure to prevent strain on the electrical connections and tighten the screws on the cable strain relief.
12. Install the power source end of the power cable according to the local electrical codes.
13. Install the circuit breaker terminal cover.
14. Proceed with **Phase Check**.

Phase Check



WARNING

Follow all high voltage safety precautions when performing this procedure to prevent the possibility of electrical shock.

1. Make sure power is applied to 9700A Compressor circuit as described in [Table 1-2](#).
- NOTE: The circuit breaker will trip immediately during step 2 if the power phase connections are not correct.*
2. Turn the 9700A Compressor circuit breaker to the ON position. If the circuit breaker trips, refer to step 3. If the circuit breaker does not trip, refer to step 4.
 3. If the circuit breaker trips, perform the following steps:
 - a. Turn the 9700A Compressor circuit breaker to the OFF position.
 - b. Shut power OFF at the power source.
 - c. Remove the circuit breaker terminal cover.
 - d. Reverse the wiring order of 9700A Compressor circuit breaker terminals X and Y.
 - e. Torque the circuit breaker terminal screws to 12 in.-lbs.
 - f. Install the circuit breaker terminal cover.
 - g. Turn power ON at the power source.
 - h. Repeat steps 1- 2 of this procedure.
 4. If the circuit breaker does NOT trip, perform the following steps:
 - a. Shut power OFF at the power source.
 - b. Install the circuit breaker terminal cover.

- c. Turn power ON at the power source.

Connecting/Disconnecting Helium Flex Lines



CAUTION

Make sure the helium flex lines are connected and disconnected from the 9700A Compressor using the following procedure and as shown in Figure 3-3. Failure to follow this procedure could damage connector O-ring seals or cause a helium circuit leak.

Connecting

1. Remove all dust plugs and caps from the Gas Supply and Return lines, and the 9700A Compressor and cryopump Supply and Return connectors. Check for the presence of a flat gasket in the male connector, and no gasket in the female connector.
2. Connect the Gas Return line to the GAS RETURN connector on the rear of the 9700A Compressor and then to the GAS RETURN connector on the cryopump. Using two wrenches as shown in Figure 3-3, tighten the connector.
3. Connect the Gas Supply line to the GAS SUPPLY connector on the rear of the 9700A Compressor and then to the GAS SUPPLY connector on the cryopump. Using two wrenches as shown in Figure 3-3, tighten the connector.
4. Attach the Supply and Return line identification labels to each end of the appropriate lines.

Disconnecting

1. Using two wrenches as shown in Figure 3-3, disconnect the two self sealing coupling connectors quickly to minimize helium leakage.

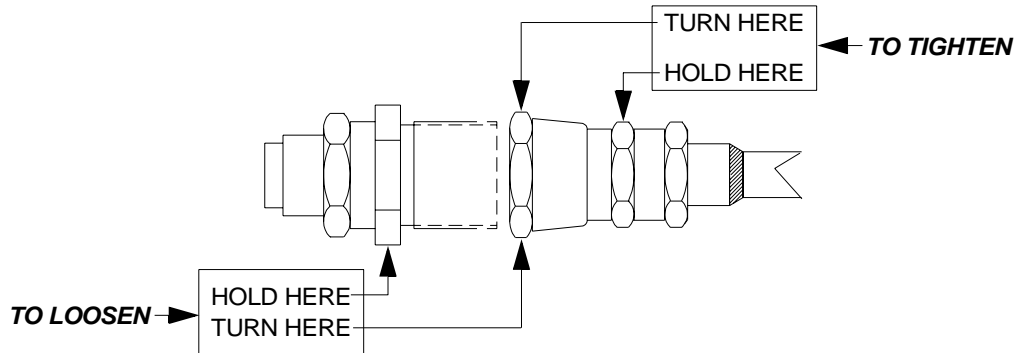

NOTE: TURN USING 1 3/16 INCH WRENCH.

NOTE: HOLD USING 1 1/8 INCH WRENCH.

Figure 3-3: Connecting/Disconnecting Helium Flex Line Self Sealing Couplings

Single On-Board Pump Connections



CAUTION

Make sure the 9700A Compressor power is OFF before making any connections to the rear panel.

1. Connect the Helium Supply and Return lines between the 9700A Compressor and the On-Board Pump as described in Connecting/Disconnecting Helium Flex Lines in this section.
2. Connect one end of the On-Board power cable to one of the PUMP POWER CONNECTORS on the rear panel of the 9700A Compressor as shown in Figure 3-4.
3. Connect the opposite end of the On-Board power cable to the

On-Board Pump power cable connector as shown in Figure 3-4.

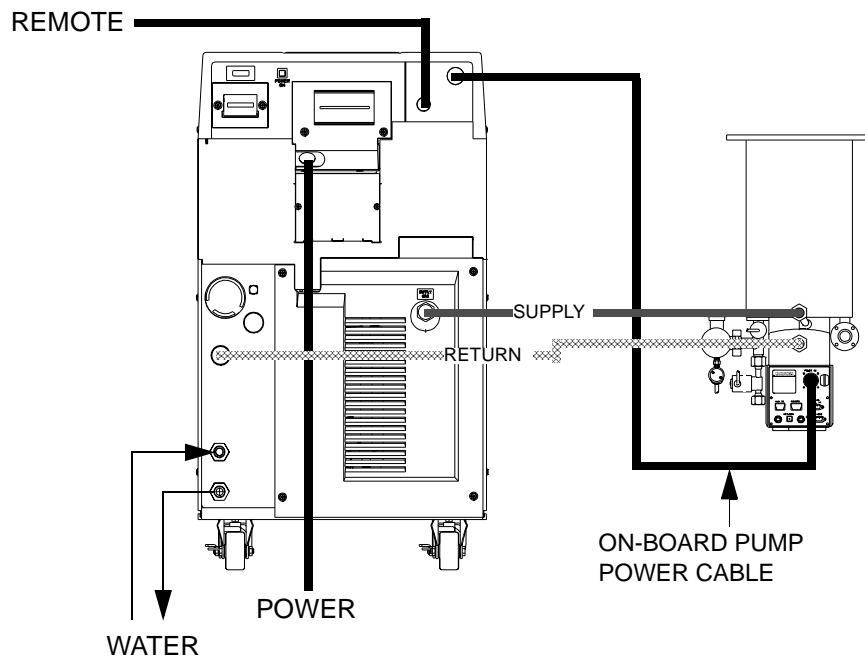

Figure 3-4: Single On-Board Pump Connections

4. If applicable, connect the compressor remote cable to the REMOTE connector as shown in Figure 3-4.
5. Refer to Section 4 - Operation to verify the system helium static charge pressure and to start the 9700A Compressor.

Single Cryo-Torr Cryopump Connections



CAUTION

Make sure the 9700A Compressor power is OFF before making any connections to the rear panel.

1. Connect the Helium Supply and Return lines between the 9700A Compressor and the Cryo-Torr Cryopump as described in Connecting/Disconnecting Helium Flex Lines within this section.
2. Connect one end of the Cryo-Torr power cable to one of the PUMP

POWER CONNECTORS on the rear panel of the 9700A Compressor as shown in Figure 3-5.

3. Connect the opposite end of the Cryo-Torr power cable to the Cryo-Torr Cryopump power cable connector.

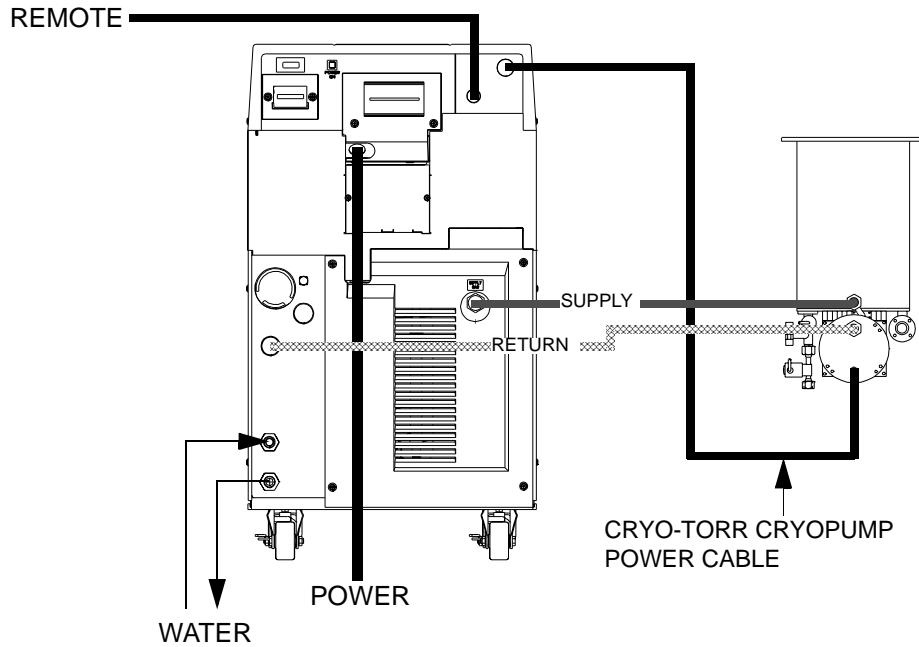

Figure 3-5: Single Cryo-Torr Cryopump Installation

4. If applicable, connect the compressor remote cable to the REMOTE connector.
5. Refer to Section 4 - Operation to verify the system helium static charge pressure and to start the 9700A Compressor.

Multiple On-Board Pump Connections



CAUTION

Make sure the 9700A Compressor power is OFF before making any connections to the rear panel.

Helium Line Connections



CAUTION

9700A Compressors cannot be connected to a helium manifold to which models other than 9700A Compressors are connected due to differences in helium running pressure.



CAUTION

The use of several 9700A Compressors on a single manifold feeding a common supply header and a common return header requires special precautions. Contact CTI-CRYOGENICS for a review of the intended installation and specific technical instructions.

1. Connect the Supply and Return lines to the 9700A Compressor as described in Connecting/Disconnecting Helium Flex Lines within this section.
2. Connect the Gas Return Line to the customer supplied helium manifold and then to the GAS RETURN connector on the On-Board Cryopump.
3. Connect the Gas Supply Line to the customer supplied helium manifold and then to the GAS SUPPLY connector on the On-Board Cryopump.

Power Cable Connections

1. Connect the On-Board power cable between the CRYOPUMP POWER CONNECTOR on the rear panel of the 9700A Compressor and the On-Board Splitter Box power connector as shown in Figure 3-6.
2. Connect the On-Board Pump power cables to the CRYOPUMP 1, 2, or 3 connectors on the On-Board Splitter Box and the respective On-Board Pumps.

NOTE: Your installation (number of pumps per 9700A Compressor) will vary based upon the On-Board Cryopump models used. Refer to Appendix A - Customer Support Information to consult your local CTI-CRYOGENICS Customer Support Center for information on specific compressor/pump applications.

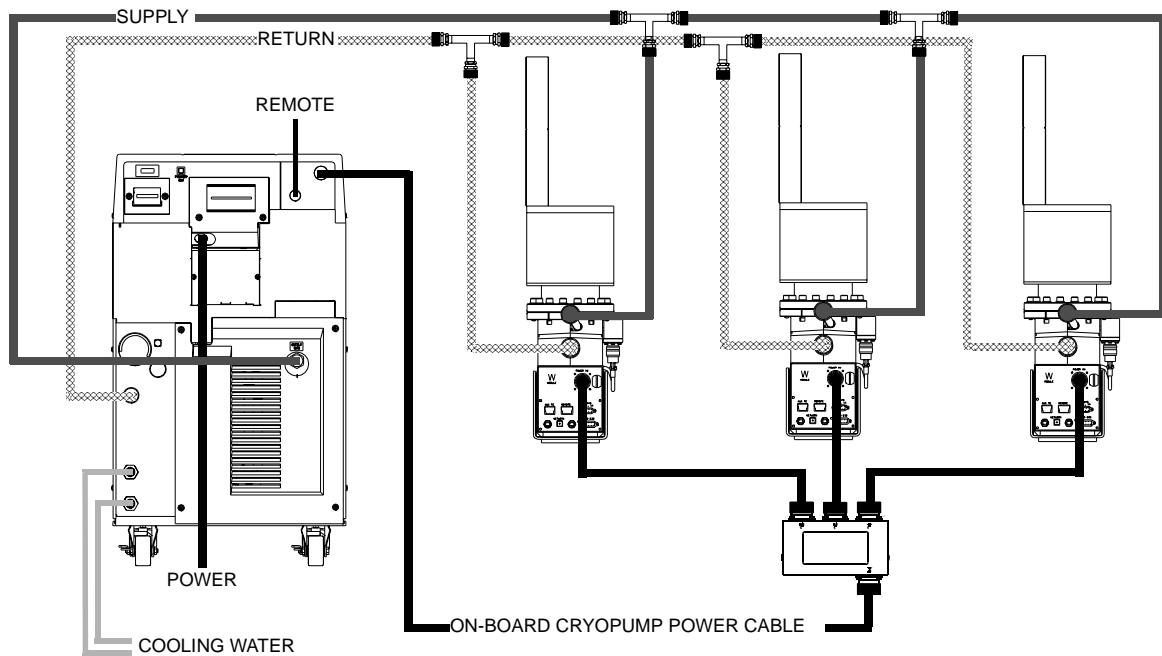

Figure 3-6: Connecting Multiple On-Board Pumps to the 9700A Compressor

Multiple Cryo-Torr Cryopump Connections



CAUTION

Make sure the 9700A Compressor power is OFF before making any connections to the rear panel.

Helium Line Connections



CAUTION

The use of several 9700A Compressors on a single manifold feeding a common supply header and a common return header requires special precautions. Contact CTI-CRYOGENICS for a review of the intended installation and for specific technical instructions.

1. Connect the Supply and Return lines to the 9700A Compressor as described in Connecting/Disconnecting Helium Flex Lines within this section.
2. Connect the Gas Return Line to the customer supplied helium manifold and then to the Gas Return connector on the Cryo-Torr Cryopump.
3. Connect the Gas Supply Line to the customer supplied helium manifold and then to the Gas Supply connector on the Cryo-Torr Cryopump.

Power Cable Connections

1. Connect the Cryo-Torr power cable between the CRYOPUMP POWER CONNECTOR on the rear panel of the 9700A Compressor and the CRYOPUMP ELECTRICAL INPUT on the Cryo-Torr Interface as shown in Figure 3-7.
2. Connect the Cryo-Torr Power Cables between the CRYOPUMP 1, 2, or 3 connectors on the Cryo-Torr Interface and the respective Cryo-Torr Cryopumps.
3. Connect the User Remote cable to the Cryo-Torr Interface.
4. Connect the Remote cable between the Cryo-Torr Interface and the 9700A Compressor.

***NOTE:** Your installation may vary based upon the Cryo-Torr Cryopump models used. Refer to Appendix A - Customer Support Information to consult your local CTI-CRYOGENICS Customer Support Center for information on specific compressor/cryopump applications.*

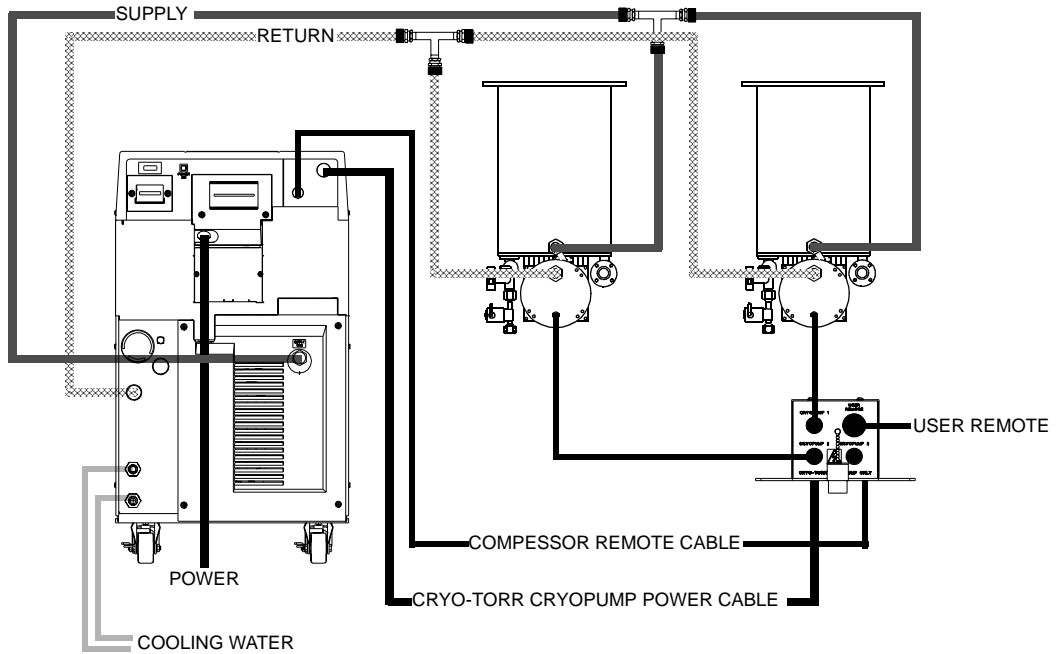

Figure 3-7: Multiple Cryo-Torr Cryopump Installation

Section 4 - Operation

Adjusting System Helium Pressure

Your CTI-CRYOGENICS high vacuum pump system is comprised of several pressurized components i.e. compressor, flex lines, and cryopumps. Each component is charged with helium before shipment. After all cryopumps, helium lines, and manifolds are attached to the compressor, the system *static helium charge pressure* must be verified *before* system operation. Once the static helium system pressure has been verified, the system is ready for operation. After cooldown, the *normal system operating pressure* is recorded.

NOTE: *The 9700A Compressor is designed for continuous operation and should remain ON even when the cryopumps are in a regeneration cycle.*

Static Helium System Pressure Verification

The proper system static helium charge pressure is necessary so that the cryopumps operate at maximum performance as well as to assure that the compressor will operate below the maximum design motor winding temperature which will maximize the life of the compressor motor.

1. Make sure the Compressor and Cryopump(s) are OFF.
2. Make sure all system components are connected together as described in Section 3 - Installation.
3. Allow all system components to acclimate to a temperature between 60° F and 80° F (15.5° C - 26.6° C).
4. Read the compressor helium pressure gauge located on the compressor rear panel as shown in [Figure 1-5](#). Compare the gauge reading to the appropriate 50/60 Hz line frequency value (depending upon your system installation) indicated in [Table 4-1](#).

Table 4-1: 9700A Compressor Helium Static Charge

Line Frequency	Helium Static Charge Pressure
60 Hz	220 - 230 psig (15.2 - 15.9 bars)
50 Hz	255 - 265 psig (17.6 -18.3 bars)

NOTE: The use of a higher helium charge pressure for 50 HZ operation is necessary in order to compensate for the slower speed at which the compressor operates at 50 HZ. The static charge level for 60 Hz remains at 220 - 230 PSIG.



CAUTION

Exceeding the recommended system static helium charge pressure will result in the compressor and cryopump safety relief valves opening and releasing excess helium gas.

5. If the static helium charge pressure is not within the ranges as indicated in [Table 4-1](#), then adjust the charge pressure as described in Section 5 - Maintenance.

Compressor Operation

The system may be operated once the helium charge pressure is correct. Perform the following steps to start the compressor:

1. Set the System Circuit Breaker to the ON (UP) position.
2. Set the Control Circuit Breaker to the ON (UP) position.
3. Close all Cryopump gate valves.
4. Refer to the appropriate **On-Board Module Programming and Operation** manual or **Cryo-Torr Cryopump Installation and Service** manual (that came with your pump) and perform the cryopump start-up procedure.
5. Once the second stage temperature for all cryopumps is below 17K, record the compressor pressure gauge reading as the *normal system operating pressure*.

NOTE: During compressor operation, the compressor gauge reads the pressure of the gas entering the compressor prior to it being compressed.

6. Affix a copy of the data next to the compressor gauge on each compressor. This data is to be verified for each tool installation and whenever a configuration change is made affecting the amount of system helium gas and line volume.

The compressor pressure reading will decrease from the normal system operating pressure during cryopump regeneration or if fewer cryopumps are being operated. These are normal variations in the compressor pressure reading and should not be cause for concern.

If you have concerns about system performance changing, then check the *normal system operating pressure* which was determined in Compressor Operation within this section. If the normal system operating pressure is not correct, check the system for leaks.

Once the leaks have been repaired, helium must be added to return the system to *normal operating system pressure* as described in Suggested Maintenance Equipment.

Replacement of Helium Circuit Components

On occasion, it may be necessary to replace components such as cryopumps, helium gas lines or compressors, or change the configuration of the system. Whenever any of these conditions occur, **Static Helium System Pressure Verification** should be performed to ensure that static helium pressure has not changed.



The use of several compressors on a single manifold feeding a common supply header and a common return header requires special precautions. Contact CTI-CRYOGENICS for a review of the intended installation and for specific technical instructions.



9700A Compressors cannot be connected to a helium manifold to which models other than 9700A Compressors are connected due to differences in helium running pressure.

Section 5 - Maintenance

Scheduled Maintenance

Suggested Maintenance Equipment

It is recommended to have the following equipment and disposable supplies available as listed in [Table 1](#).

NOTE: Refer to Appendix A - Customer Support Information and contact the local Customer Support Center to obtain the CTI-CRYOGENICS parts listed in this table.

Table 5-1: Suggested Maintenance Equipment

Supply	CTI-CRYOGENICS P/N
Helium, 99.999% pure	-
Pressure regulator (0-3000/0-400 psi) Assy.	8031403
Helium charging line terminating in a 1/4-inch female flare fitting	7021002P001

Adsorber Replacement

Use the following procedure to change the adsorber every three years.

1. Set the System Circuit Breaker, on the rear of the 9700A Compressor, to the OFF position.
2. Remove the four screws which secure the rear panel to the Compressor and remove the rear panel.

NOTE: Use two wrenches in Step 3 to prevent loosening the body of the coupling.

3. Using a 1-3/16 in. wrench, and a 1-1/8 in. wrench, as shown in [Figure 5-1](#), disconnect the two self sealing coupling connectors quickly to minimize helium leakage.

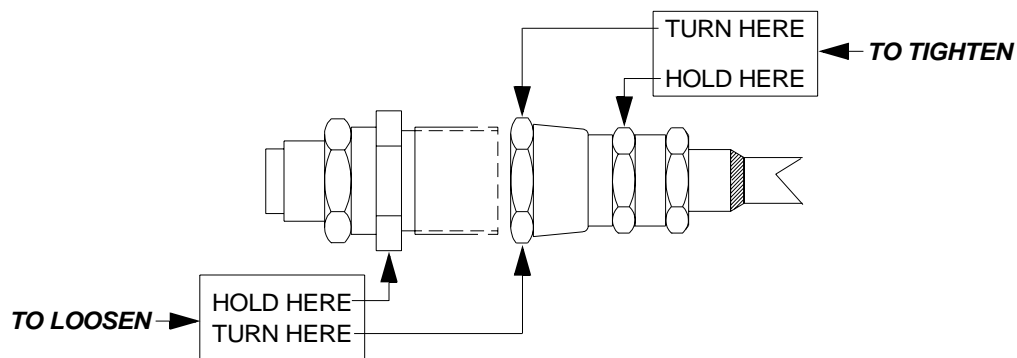

NOTE: TURN USING 1 3/16 INCH WRENCH.

NOTE: HOLD USING 1 1/8 INCH WRENCH.

Figure 5-1: Disconnecting Self Sealing Couplings

4. Using a 7/16 in. (11mm) wrench, remove the adsorber mounting bolt as shown in [Figure 5-2](#).
5. Move the adsorber from under the mounting tabs in the base as shown in and remove the adsorber from the Compressor.
6. Install the replacement adsorber under the mounting tabs and secure it into place with the bolt removed during Step 4.
7. Using two wrenches as shown in [Figure 5-1](#), connect the two self sealing couplings quickly to minimize helium leakage.
8. Install the Compressor rear panel.

9. Ensure that the pressure gauge reads the proper value as shown in [Table 4-1](#). If additional gas pressure is required, refer to **Adding Helium** within this section. If gas pressure needs to be reduced, refer to **Reducing Helium Pressure** within this section.
10. Record the adsorber replacement date on the label as shown in [Figure 5-2](#), and also note that the next adsorber replacement should be performed every three years.

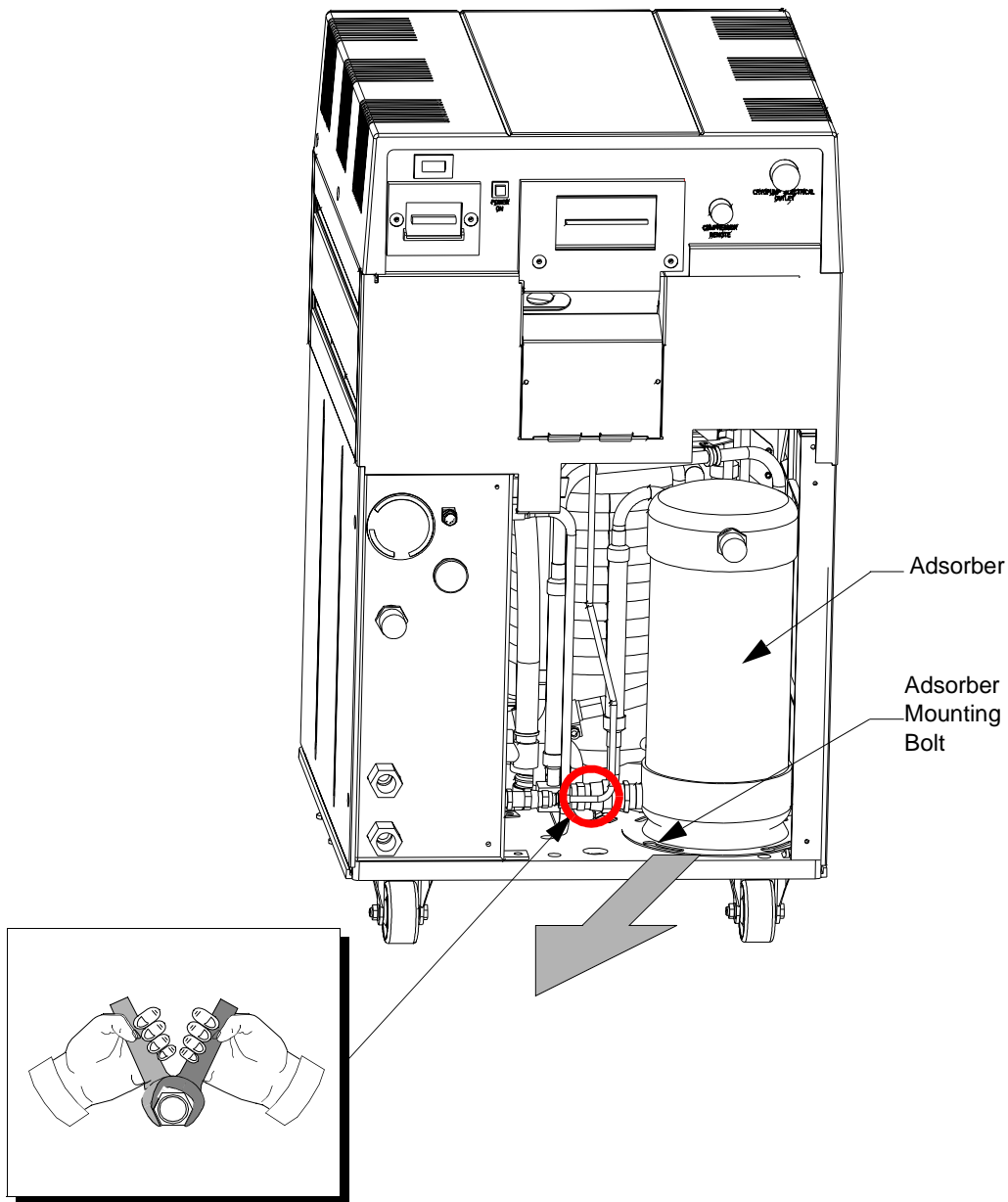

Figure 5-2: Adsorber Location in the 9700A Compressor (Rear Panel Removed)

Adjusting System Helium Pressure

NOTE: These procedures can be performed on a compressor that is turned ON or OFF. However, the helium pressure gauge should be set to the static helium charge pressure value if the compressor is turned OFF or set to the normal system operating pressure if the compressor is turned ON. Refer to Section 4 - Operation for more information.

Reducing Helium Pressure

NOTE: You must obtain the normal system operating pressure from the Compressor Operation procedure in Section 4 - Operation in order to perform this procedure. If the normal system operating pressure is unknown, then shut the compressor OFF and perform the Static Helium System Pressure Verification procedure in Section 4 - Operation instead.

1. Remove the flare cap from the gas charge fitting as shown in Figure 5-3.

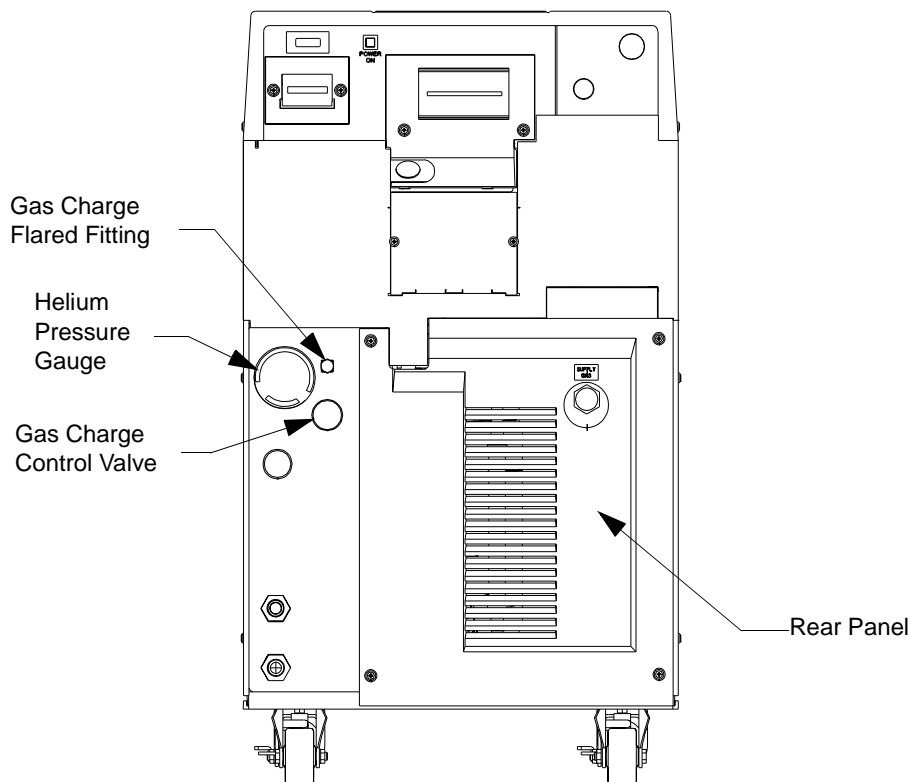

Figure 5-3: Helium Pressure Control Components

2. Open the gas charge control valve *very slowly* to allow a slight amount of helium to escape. Leave the valve open until the helium pressure gauge indicates one of the following:
 - The appropriate value in [Table 4-1](#) if the compressor is OFF and acclimated to a temperature between 60° F and 80° F (15.5° C - 26.6° C).
 - The value previously recorded in the **Compressor Operation** procedure in Section 4 - Operation if the compressor is ON.
3. Close the gas charge control valve and install the flare cap.

Increasing Helium Pressure

Use the following procedure to increase the helium pressure if the indicated pressure is below the appropriate value as shown in [Table 4-1](#).



CAUTION

If helium is being added more than once every several months, check for leaks caused by improperly connected self-sealing connections or any mechanical joint within the Compressor.

Adding Helium

NOTE: You must obtain the normal system operating pressure from the **Compressor Operation** procedure in Section 4 - Operation in order to perform this procedure. If the normal system operating pressure is unknown, then shut the compressor OFF and perform the **Static Helium System Pressure Verification** procedure in Section 4 - Operation instead.

This procedure ensures that both the regulator and the charging line will be purged of air and that the air trapped in the regulator will not diffuse back into the helium bottle. For best results, CTI-CRYOGENICS suggests a dedicated helium bottle, regulator, and line, which are never separated, for adding helium.

NOTE: You are required to supply the helium charging line terminating in a 1/4-inch female flare fitting, and a two-stage pressure regulator rated at 0-3000/0-400 psig for this operation.



CAUTION

Use only 99.999% pure helium gas. Helium circuit contamination may result if a lower quality of helium is used.

1. Attach a regulator (0-3000/0-400 psig) and charging line to a helium bottle (99.999% pure).

NOTE: *Do not open the bottle at this time.*

2. Purge the regulator and charging lines as follows:
 - a. Open the regulator a small amount by turning the adjusting knob clockwise until it contacts the diaphragm, then turn approximately 1/8 to 1/4 turn more, so that the regulator is barely open.
 - b. Loosely connect the charge line to the helium pressure regulator.
 - c. Slowly open the bottle valve, and purge the regulator and line for 10 to 15 seconds. Turn the regulator knob counterclockwise until the helium stops flowing.
3. Remove the flare cap of the gas charge flared fitting on the rear of the Compressor.
4. Loosely connect the charging line from the helium pressure regulator to the 1/4-inch male flare fitting installed on the helium charge valve. Purge the charge line again, as in step a, for 30 seconds, and tighten the charge line flare fitting onto the gas charge fitting while the helium is flowing.
5. Set the helium pressure regulator to 300 psig (20.7 bars). If the compressor is ON, proceed with step a. If the compressor is OFF, proceed with step b.
 - a. Obtain the previously recorded *normal system operating pressure* from the **Compressor Operation** procedure in Section 4 - Operation. Open the gas charge control valve *very slowly* and allow helium to flow until the compressor gauge reading is the same as the value obtained from Section 4 - Operation. Quickly close the gas charge control valve.
 - b. Obtain the appropriate (50 or 60 Hz) *static system operating pressure* from [Table 4-1](#). Open the gas charge control valve

very slowly and allow helium to flow until the compressor gauge reading is the same as the appropriate value in [Table 4-1](#). Quickly close the gas charge control valve.

6. Ensure that the helium charge valve on the Compressor is tightly closed. Shut off the helium pressure regulator on the helium bottle and remove the charging line from the male flare fitting. Reinstall the flare cap.

Appendix A - Customer Support Information

Customer Support Center Locations

To locate a Customer Support Center near you, please visit our website www.helixtechnology.com on the world wide web and select *CONTACT* on the home page.

Guaranteed Up-Time Support (GUTS®)

For 24-hour, 7-day per week Guaranteed Up-Time Support (GUTS) dial:

1 800-367-4887 - Inside the United States of America

+1 508-337-5599 - Outside the United States of America

Product Information

Please have the following information available when calling so that we may assist you:

- Product Part Number
- Product Serial Number
- Product Application
- Specific Problem Area
- Hours of Operation
- Equipment Type
- Vacuum System Brand/Model/Date of Manufacture

E-mail

For your convenience, you may also e-mail us at:

techsupport@helixtechnology.com

Appendix B - Flow Diagram

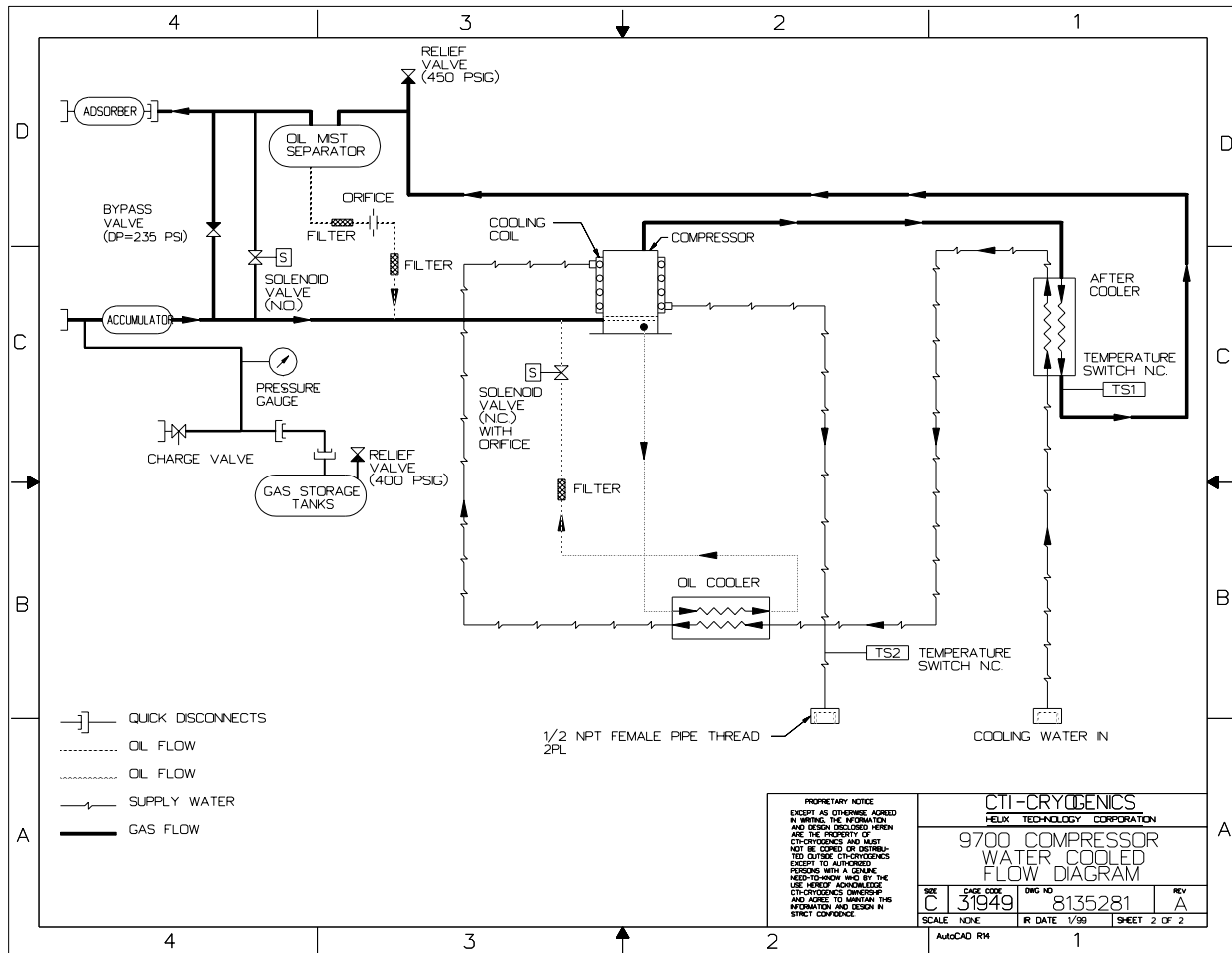

Figure B-1: 9700A Compressor Flow Diagram

Appendix C - Troubleshooting Procedures

Troubleshooting the Compressor

The compressor troubleshooting procedures are summarized in [Table C-1](#).

Technical Inquiries

Please refer to Appendix A - Customer Support Information of this manual for a complete list of the CTI-CRYOGENICS' world wide customer support centers.



WARNING

Disconnect the compressor before performing any troubleshooting procedures. Do not change or modify any compressor internal wiring circuits, this may cause failure of the compressor and cold head due to improper phasing.



WARNING

The compressor pump is hot after operating. Wait for the pump to cool down before working on the inside of the compressor.

Table C-1: Compressor Troubleshooting Procedures

Problem	Possible Cause	Corrective Action
1) System circuit breaker (CB1) trips immediately to the OFF (0) position when switched to the ON (1) position.	1) Incorrect phasing of input power.	1) Check phasing of input power. Refer to Phase Check in Section 3 - Installation.
2) System (CB1) and Control Circuit (CB2) circuit breakers remain in the ON (1) position when switched ON but the compressor will not run.	1) No power coming from source. 2) Insufficient power 3) Remote control jumper plug not in place. This will apply only if remote circuit <i>is not</i> being used. 4) Improperly wired external remote control circuit. NOTE: Only applies if remote control feature is being used.	1) Check source fuses, circuit breakers, and wiring associated with the power source. Repair as needed. 2) Verify adequate phase-to-phase input voltage. Refer to Table 1-2 . 3) Check to insure that remote jumper plug is fully seated. See Figure 1-4 for location. Refer to Compressor Remote Connector in Section 1 - 9700A Compressor Description for more information. 4) Verify correct installation of remote control feature. Refer to Table 1-6 .

Table C-1: Compressor Troubleshooting Procedures (Continued)

Problem	Possible Cause	Corrective Action
<p>3) System circuit breaker (CB1) will not remain in the ON (1) position when switched ON. The Control Circuit circuit breaker (CB2) trips when excessive current is being drawn by the cold head or 24 volt compressor control circuits.</p>	<p>1) Damaged On-Board power cable, connectors, or drive motor.</p> <p>2) Damaged component in the compressor power or control circuit.</p>	<p>1) Check for compressor operation with cryopump cable disconnected from compressor. Refer to <i>Appendix A - Customer Support Information</i> to contact the Customer Support Center if the compressor operates improperly.</p> <p>2) Refer to <i>Appendix A - Customer Support Information</i> to contact the Customer Support Center.</p>
<p>4) System circuit breaker (CB1) remains in the ON (1) position and the compressor stops after several minutes of operation and remains OFF (0).</p>	<p>1) Thermal protective switches are open.</p> <p>2) Very cold water has caused a restriction of oil flow through the oil injection orifice during start-up.</p>	<p>1) Check for inadequate water cooling. Refer to Table 1-3.</p> <p>2) Recheck for proper cooling water temperature. Refer to Table 1-3. Restart compressor repeatedly until continuous operation is achieved.</p>
<p>5) System circuit breaker (CB1) trips after a period of running.</p>	<p>1) Loss or degradation of power from the source.</p> <p>2) Defective motor windings.</p>	<p>1) Check that line voltage is correct on all phases.</p> <p>2) Check running current on all phases.</p> <p>3) Refer to <i>Appendix A - Customer Support Information</i> to contact the local Customer Support Center.</p>

Appendix D - Schematic

Introduction

The schematic in Appendix D supports the 9700A (Low Voltage) Compressor CTI-CRYOGENICS P/N 8135443P001.

Table D-1: Basic Control Assembly Legend

Identifier	Description
1M	Compressor Motor
J15	Module Power Receptacle
J1/P1	Autoset Power Connector
J2/P2	Unload Solenoid Connector
J3/P3	Oil Solenoid Connector
J4/P4	Thermostat
J5/P5	Thermostat
J6/P6	Compressor Contactor Coil
J7/P7	Output Connector
CB1	Main Circuit Breaker (25A)
CB2	Control Circuits Circuit Breaker (7A)
ETM1	Elapsed Time Meter
M1	Contactor 7.5 HP IEC
M1OL	Relay, Overload (16-24A)
PM1	Phase Monitor OMRON RDR-TFY-M
PWB1	PWB Autoset
T3	Transformer Assembly Control
LT1	Lamp, 24-28V LED Green
J8/P8	ETM1 Connector
J9/P9	LT1 Connector

Table D-1: Basic Control Assembly Legend (Continued)

Identifier	Description
J10/P10	T3 Input Connector
J11	Open
J12	Module Signal Connector
J13/P13	Phase Monitor
J14	Open
J15	Cryo Power Output
K2	Over Temperature Lockout Relay

Table D-2: On-Board/Cryo Electrical Module Legend

Identifier	Description
JT1	Open
JT2	Open
JT3/PT3	T2 Cold Head Supply, 2 phase
JT4/PT4	T1 Cold Head Supply, 2 phase
JT5/PT5	T2 Cold Head Transformer Output
JT6/PT6	T1 Cold Head Transformer Output
JT7/PT7	T4 Supply
JT8/PT8	T4 Low Voltage Output (23/26 VCT)
J18	Power Output
J19	Signal Output
P12	Signal Connector
P15	Power Connector
K2	Cold Head Voltage Relay
K1	Signal Voltage Relay
T1	Cold Head Supply
T2	Cold Head Supply

Table D-2: On-Board/Cryo Electrical Module Legend (Continued)

Identifier	Description
T4	Low Voltage Supply
J16	Three Phase Inverter Output
J20	Inverter Input

Table D-3: On-Board Output Module P/N 8135148G001 Legend

Identifier	Description
J30	On-Board Output Receptacle
J31	Remote Control Receptacle
P18	Power Connector
P19	Signal Connector
P31	Remote Jumper

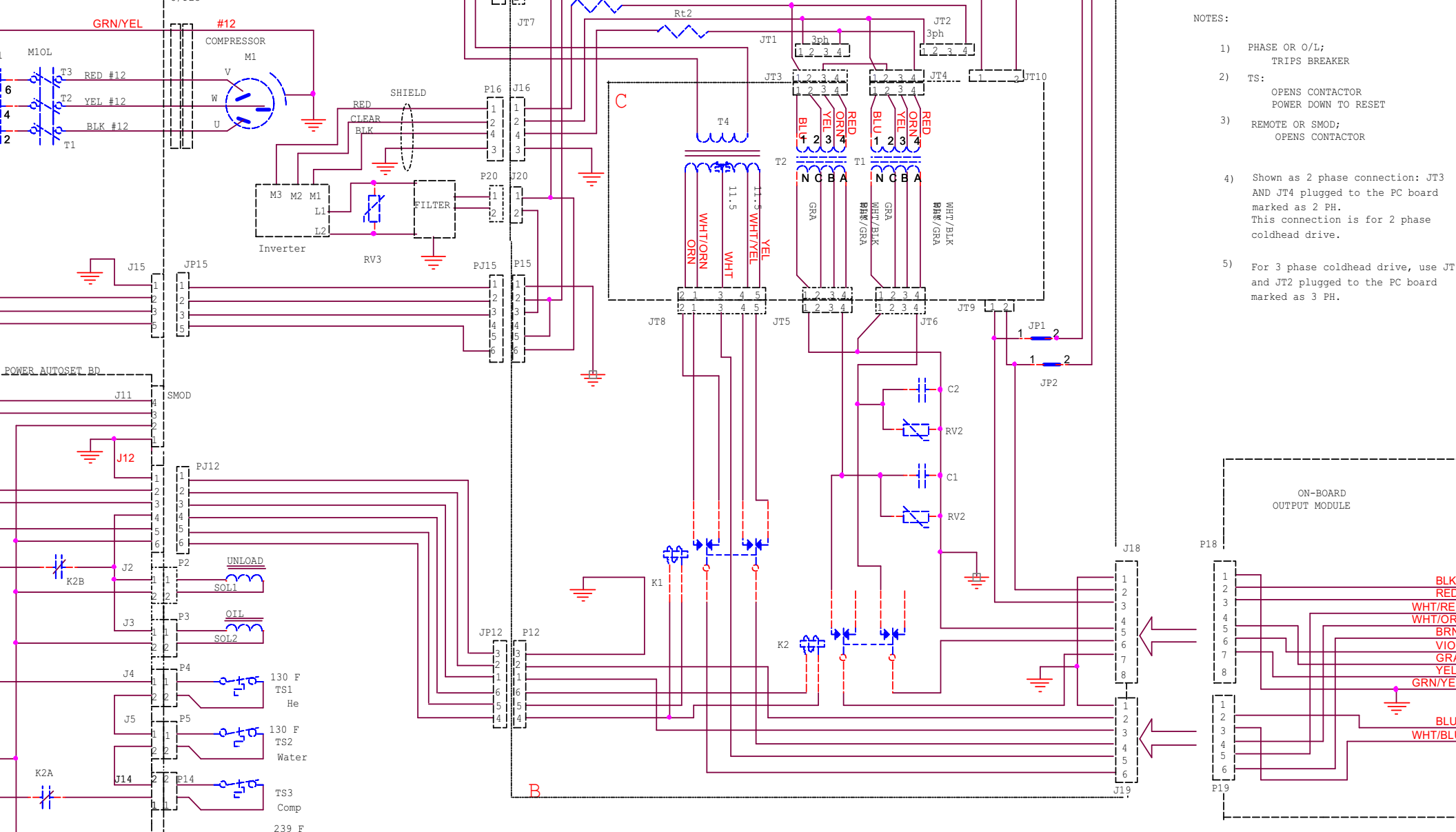

- NOTES:
- 1) PHASE OR O/L;
TRIPS BREAKER
 - 2) TS:
OPENS CONTACTOR
POWER DOWN TO RESET
 - 3) REMOTE OR SMOD;
OPENS CONTACTOR
 - 4) Shown as 2 phase connection: JT3
AND JT4 plugged to the PC board
marked as 2 PH.
This connection is for 2 phase
coldhead drive.
 - 5) For 3 phase coldhead drive, use JT
and JT2 plugged to the PC board
marked as 3 PH.

CIRCUIT BREAKER PROTECTOR	
93 C	
93 C	

PROPRIETARY NOTICE

EXCEPT AS OTHERWISE AGREED IN WRITING, THE INFORMATION AND DESIGN DISCLOSED HEREIN ARE THE PROPERTY OF HELIX TECHNOLOGY CORPORATION AND MUST NOT BE COPIED OR DISTRIBUTED OUTSIDE HELIX EXCEPT TO AUTHORIZED PERSONS WITH A GENUINE NEED-TO-KNOW WHO BY THE USE HEREOF ACKNOWLEDGE HELIX OWNERSHIP AND AGREE TO MAINTAIN THIS INFORMATION AND DESIGN IN STRICT CONFIDENCE.

ENVIRONMENTAL STATEMENT

SELLER'S GOODS SHALL NOT BE MANUFACTURED WITH OR CONTAIN CLASS I ODS'S AS DEFINED UNDER SECTION 602 OF THE FEDERAL CLEAN AIR ACT (42 USC SECTION 7671A) OR ANY NEW APPLICABLE REGULATIONS.

BY	DATE
IR DATE	HH 02/02
LAST CHANGE	
ECO NO.	14727

HELIX TECHNOLOGY CORPORATION

9 HAMPSHIRE STREET
MANSFIELD, MA 02048
508-337-5000

SCHEMATIC, 9700A COMPR. LOW VOLTAGE

SIZE	CAGE CODE	DWG NO
B	31949	8135443P001
		Monday, January 19, 2004
		SHEET 1

Index

A

Adjusting system helium pressure, 5-4
Adsorber cartridge
 replaceable, 1-2
Adsorber replacement, 5-2

C

Circuit breaker, 1-11
Circuit component, helium
 replacing, 4-3
Compressor
 schematic, D-1
 starting, 4-2
Compressor flow diagram, B-1
Compressor installation, 3-1
Compressor operation, 4-2
Compressor remote connector, 1-13
Compressor safety, S-1
Configurations
 compressor, 1-1
Connections
 electrical, 3-4
Cooling Water, 1-6
Cryopump electrical outlet, 1-14
Cryo-Torr pumps
 connections, 1-15

E

Elapsed Time Meter, 1-11
Electrical connections, 3-4
Electrical specifications, 1-5

F

Flex lines
 connecting, disconnecting, 3-7
Flow diagram, B-1
Flow rate, 1-7

G

Gas return connector, 1-9
Gas supply connector, 1-9

H

Helium
 adding, 5-5
Helium circuit components
 replacing, 4-3
Helium flex lines
 disconnecting, connecting, 3-7
Helium pressure
 adjusting, 4-1, 5-4
Helium refrigeration
 systems, 1-1
Helium system pressure
 static, 4-1

I

Inspection
 compressor, 2-5
Installation
 compressor, 3-1
 multiple cryopumps, 3-13
 multiple on-board pumps, 3-11
 phase check, 3-6
 single cryopump, 3-9
 single on-board pump, 3-8
 water line connections, 3-3

M

Maintenance, 5-1
manifold, 1-1
Multiple Cryo-Torr cryopump, 3-13
Multiple on-board pump connections, 3-11

O

On-Board Pumps, 1-14
On-board splitter box, 1-14
Outlet
 electrical, 1-14

P

Phase check, 3-6

R

Ramp

 unpacking, 2-1

Refrigeration system, 1-1

S

Safety

 compressor, S-1

Schematic, D-1

Shipping carton, 2-1

Single Cryo-Torr cryopump, 3-9

Single Cryo-Torr Cryopump Installation, 3-10

Single on-board pump, 3-8

Specifications, 1-4

 operating, 1-9

Splitter box

 on-board, 1-14

T

Troubleshooting, C-1\+C-3

U

Unpacking

 carton contents, 2-5

 compressor inspection, 2-5

 description, 2-1

 ramp, 2-1

W

Water line connections, 3-3

weight, 1-5