

8300 Compressor Installation, Operation and Maintenance Instructions

8040242
Rev. 100 (7/2002)

Helix Technology Corporation no longer manufactures this product.
Please contact Technical Support at 1-800-284-2796
(1-508-337-5551 outside the U.S.) for product upgrade options.

June 14, 2005

The information in this document is believed to be accurate and reliable. However, Helix Technology Corporation, cannot accept any financial or other responsibilities that may result from the use of this information. No warranties are granted or extended by this document.

Helix Technology Corporation reserves the right to change any or all information contained herein without prior written notice. Revisions may be issued at the time of such changes and/or deletions.

Any duplication of this manual or any of its parts without expressed written permission from Helix Technology Corporation is strictly prohibited.

Any correspondence regarding this document should be forwarded to:

Helix Technology Corporation
Mansfield Corporate Center
Nine Hampshire Street
Mansfield, Massachusetts 02048-9171 U.S.A.

Telephone: (508) 337-5000
FAX: (508) 337-5464

The following Helix Technology Corporation trademarks and service marks may appear in this document:

Conductron™	Convectron®	Cryodyne®	Cryogen®
Cryogenerator®	Cryo-Torr®	CTI-Cryogenics®	FastRegen™
GOLDLink®	Granville-Phillips™	GUTS®	Helix Technology.. Your Vacuum Connection SM
Helix®	Micro-Ion®	Mini-Ion™	On-Board®
RetroEase®	RetroFast®	Stabil-1®	Stabil-Ion®
ThinLine™	TurboPlus®	Vacuum Assurance SM	

All other trademarks or registered trademarks are the property of their respective holders.

Customer Support Information

Customer Support Center Locations

To locate a Customer Support Center near you, please visit our website www.helixtechnology.com on the world wide web and select *CONTACT* on the home page.

Guaranteed Up-Time Support (GUTS)

For 24 hour, 7 day per week Guaranteed Up-Time Support (GUTS) dial:

800-367-4887 - Inside the United States of America

508-337-5599 - Outside the United States of America

Product Information

Please have the following information available when calling so that we may assist you:

- Product Part Number
- Product Serial Number
- Product Application
- Specific Problem Area
- Hours of Operation
- Equipment Type
- Vacuum System Brand/Model/Date of Manufacture

E-mail

For your convenience, you may also e-mail us at:

techsupport@helixtechnology.com

Contents

Section

- 1. Introduction
- 2. Inspection
- 3. Installation
- 4. Maintenance Procedures

Appendices

- A. Troubleshooting Procedures
- B. Electrical Schematic for 8300 Compressor
- C. Flow Diagram for 8300 Compressor

Illustrations

- 1.1 8300 Compressor vi
- 1.2 8300 Compressor - location of components 1-3
- 2.1 Removing the compressor bottom shipping cushion. 2-2
- 3.1 Installing cartridge support bracket on compressor. 3-1
- 3.2 Installing the cartridge 3-2
- 3.3 Typical component installation setup. 3-4
- 4.1 Disconnecting the cartridge self-sealing coupling. 4-2
- 4.2 Removing the cartridge from the compressor 4-2
- B.1 Electrical Schematic for 8300 Compressor
Drawing No. 8052208 Rev. A B-1
- C.1 Flow Diagram for the 8300 Compressor C-1

Tables

- 1.1 8300 Compressor Specifications 1-2
- 4.1 Typical pressure variations during normal operation (CT-100, 7, 8, 8F
and On-Board 8/8F 4-3
- A.1 Troubleshooting the Compressor. A-2

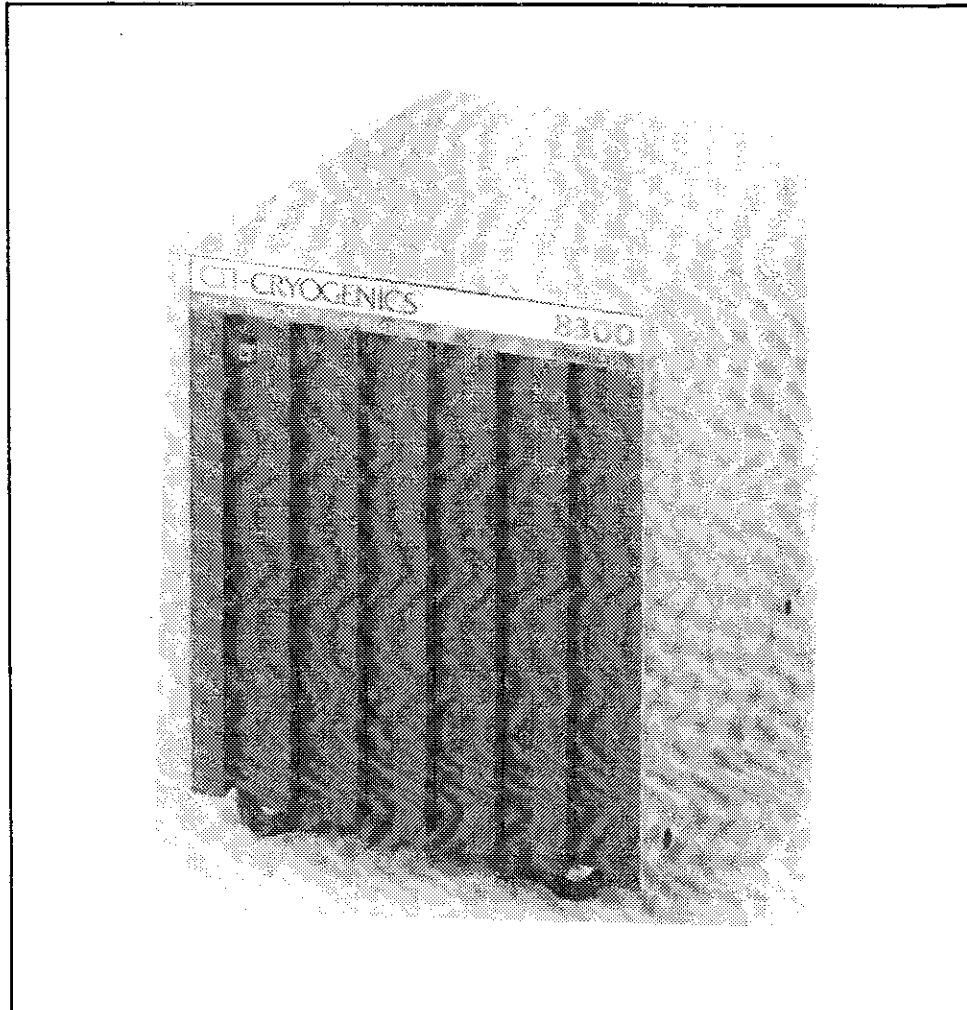

Figure 1-1: 8300 Compressor

Section 1 Introduction

1.1 General 1-1
1.2 Installation, Operation and Servicing Instructions 1-1

1.1 General

This manual provides instructions for installing, operating and servicing the 8300™ Compressor, P/N 8052005. If you are installing or operating a Cryo-Torr or ON-BOARD® High-Vacuum System you should also have available the manuals listed below that apply to your particular system.

SYSTEM COMPONENT	MANUAL REQUIRED	
	ON-BOARD 8/8F	CRYO-TORR 100, 7, 8 AND 8F CRYOPUMP
High-Vacuum Pump	8040215	8040240
8300 Compressor	8040242	8040242
8001/8002 Controller	---	8040241
8004 Controller	8040217	---
8005 Controller	8040234	---

The manuals cover three basic components: the high-vacuum pump, compressor, and the controller. Each manual simplifies the details necessary for installation, operation and servicing of that component. A manual is shipped with each system component (high-vacuum pump, compressor, and controller).

When you purchase a system, you will receive the three manuals necessary for system installation, plus a loose-leaf binder with index tab separators, allowing you to compile a complete indexed notebook.

1.2 Installation, Operation and Servicing Instructions

Installation, Operation and Servicing Instructions for your 8300 Compressor provide easily accessible information. All personnel with installation, operation, and servicing responsibilities should become familiar with the contents of these instructions to ensure high quality, safe, and reliable performance.

Table 1.1 8300 Compressor Specifications

Dimensions

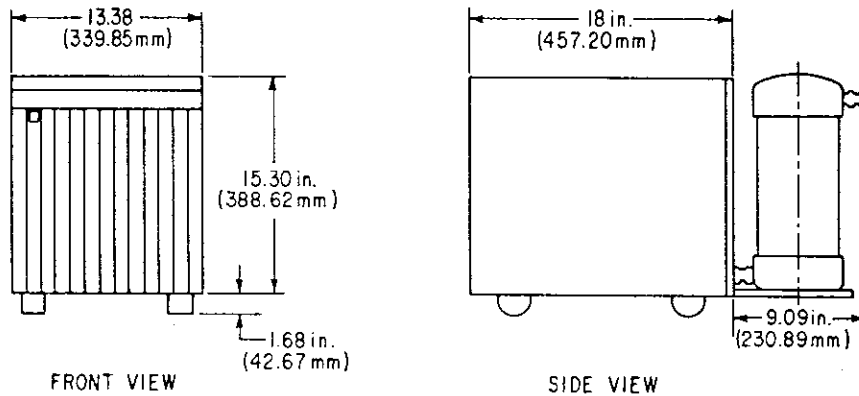

8300 Compressor, P/N 8052005

Weight (including cartridge)
128 lbs (58 kg), approximate

Weight (shipping) (including cartridge)
131 lbs (59 kg), approximate

Helium pressure
Static: 245-250 psig (1690-1725 kPa) at 70 to 80°F (21 to 27°C)
Return: normal operation: Refer to Table 4.1, page 4-3, for operating pressure.

Ambient operating temperature range
50 to 100°F (10 to 38°C)

Interface

- Compressor control power receptacles: Mates with compressor control power cable plug from controller.
- Compressor power receptacle: Mates with compressor or power cable plug from controller.
- Cooling water inlet and outlet connections: Mates with 1/2-14 NPT (fittings are supplied).
- Gas-supply connector: 1/2-inch self-sealing coupling (female) (mates with cartridge).
- Gas-return connector: 1/2-inch self-sealing coupling (male).

Helium filtration cartridge service schedule
Replace every 12 months

Cooling water requirements
70°F water supply, 0.5 gpm, 3.5 psid (pressure drop: water inlet to water outlet).
The pressure value does not consider discharge back-pressure conditions.
Maximum/minimum water requirements
Maximum outlet temperature 90°F (32°C)
Minimum inlet temperature 40°F (4°C)
Maximum inlet pressure 100 psig

This compressor has been designed to operate with water having a pH value of 6.0 to 8.0 and a calcium carbonate concentration of less than 75 parts per million (typical municipal drinking water quality). For applications of lower pH or greater hardness, water conditioning may be necessary.

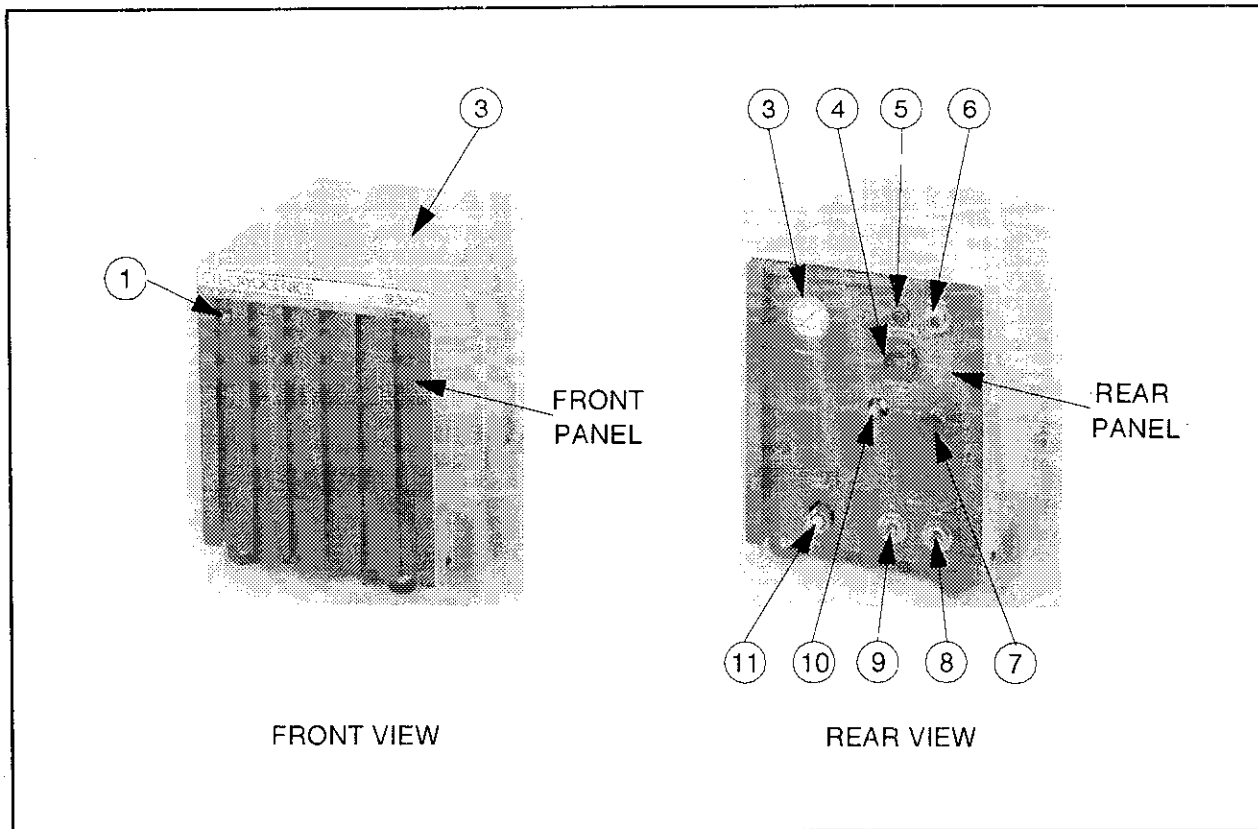

Legend

1. Compressor power indicator; illuminates when power is ON.
2. Cover.
3. Helium return pressure gauge.
4. Compressor power receptacle.
5. Compressor control power receptacle.
6. Helium gas-return connector self-sealing coupling.
7. Helium gas charge valve.
8. Cooling water output.
9. Cooling water input.
10. Helium gas charge fitting.
11. Helium gas-supply connector self-sealing coupling.

Figure 1.2 8300™ Compressor - location of components

This page intentionally left blank.

Section 2 Inspection

2.1 Packaging of the System 2-1
2.2 The Compressor 2-2

2.1 Packaging of the System

A Cryo-Torr or ON-BOARD High-Vacuum Pump System is packaged in four separate cartons. Listed below are the contents of each carton, as they relate to these two system applications. Note that an Installation, Operation, and Servicing Manual is included in cartons for the high-vacuum pump, compressor, and controller; each manual covers the component packaged in that carton.

When installing a Cryo-Torr or ON-BOARD High-Vacuum Pump System, CTI recommends that as you unpack a component; you then perform an inspection and the necessary tasks for system installation for the component according to the manual (included with the component). Final system installation and operation will be performed following procedures in the cryopump manual (8040240) or the ON-BOARD 8/8F manual (8040215).

CRYO-TORR/ON-BOARD HIGH-VACUUM PUMP SYSTEM			
CARTON LABEL	CRYO-TORR 100, 7, 8 OR 8F	ON-BOARD 8/8F	MANUAL NO.
CRYO-TORR®	Cryo-Torr 100, 7, 8 and 8F High-Vacuum Pump System	—	8040240
ON-BOARD®	—	ON-BOARD 8/8F High-Vacuum Pump System	8040215
Compressor	8300 Compressor	8300 Compressor	8040242
Accessories	Maintenance Tool Kit and Accessories, P/N 8032040G013	Maintenance Tool Kit and Accessories, P/N 8032040G005	—
Controller	8001 or 8002 Controller	—	8040241
Controller	—	8004 Controller	8040217
Controller	—	8005 Controller	8040234

2.2 The Compressor

On receipt, remove the 8300 Compressor from its shipping carton and inspect the compressor for evidence of damage as described in this Section.

CAUTION

The compressor bottom shipping cushion will be attached to the compressor. Do not attempt to remove shipping cushion without removing the shipping bolt.

1. Unpackage and remove the compressor from its shipping carton.
2. Check the carton contents. It should contain:
 - a. 8300 Compressor.
 - b. Two barbed fittings for compressor cooling water connections.
 - c. Cartridge support bracket, P/N 8052029 and cartridge attaching hardware.
 - d. Compressor cartridge, P/N 8080280K001.
 - e. Two shoulder screws for side mounting the controller on the compressor.
 - f. Compressor Manual, P/N 8040242.
3. Refer to Figure 2.1 and remove the bottom shipping cushion and shipping bolt from the compressor as follows:
 - a. Carefully tilt and set the compressor on its rear panel so the shipping bolt is accessible.
 - b. Loosen the shipping bolt from the underside of the bottom shipping cushion until the cushion can be removed from the compressor. Retain the cushion and shipping bolt for use during future compressor shipment.

CAUTION

Always place the compressor back on its bottom shipping cushion and install the shipping bolt (wrench-tight) whenever you ship the compressor by common carrier. This will prevent damaging the compressor pump during transportation.

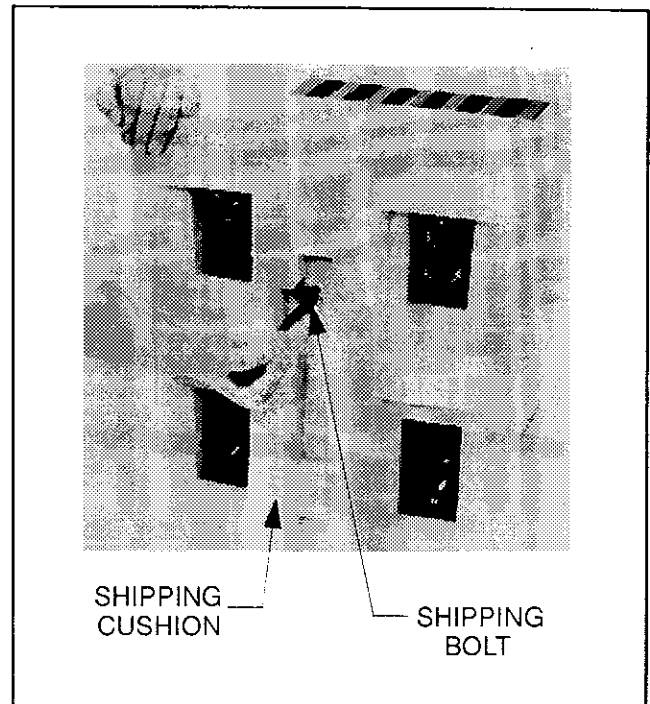

Figure 2.1 Removing the compressor bottom shipping cushion

4. After unpackaging, inspect the compressor for evidence of damage as follows:
 - a. Inspect the compressor overall exterior for damage and evidence of oil leakage.
 - Report damage to the shipper at once.
 - Retain shipping cartons for storage or return shipment.
 - b. Check the helium pressure gauge. The gauge should indicate 245 psig (1690 kPa) minimum at 70°F. If additional gas pressure is required, follow the instructions in Section 4.2, page 4-3, under Adding Helium Gas.

Section 3 Installation

3.1 General	3-1
3.2 Installing the Compressor Cartridge	3-1
3.3 Cooling Water Requirements	3-2
3.4 Connecting the Compressor to the Cryopump	3-3
3.5 Electrical Connection of Compressor to Controller	3-3

3.1 General

Your 8300 Compressor consists of two separate modules: a compressor and a helium filtration cartridge. Installation of your 8300 Compressor is an easy task requiring no special tools other than those supplied in the Installation and Scheduled Maintenance Tool Kit.

Included with your compressor are two barbed fittings and a cartridge support bracket, (with cartridge attaching hardware).

3.2 Installing the Compressor Cartridge

For Your Information —

If remote cartridge location is desired, contact your sales representative or the Product Service Department to order appropriate interconnecting lines. Connect the interconnecting line between the compressor and cartridge, following the procedures in this section.

Connect the cartridge to the compressor gas-supply connector located at the rear of the compressor.

1. Install the cartridge support bracket over the compressor gas-supply connector. See Figure 3.1.
2. Remove the dust caps from the lower self-sealing coupling of the cartridge and from the compressor supply coupling.

3. Check the self-sealing connector flat rubber gasket to make sure that it is clean and properly positioned.
4. Make the first turns by hand and then firmly seal the connection using the two wrenches until the fittings bottom.

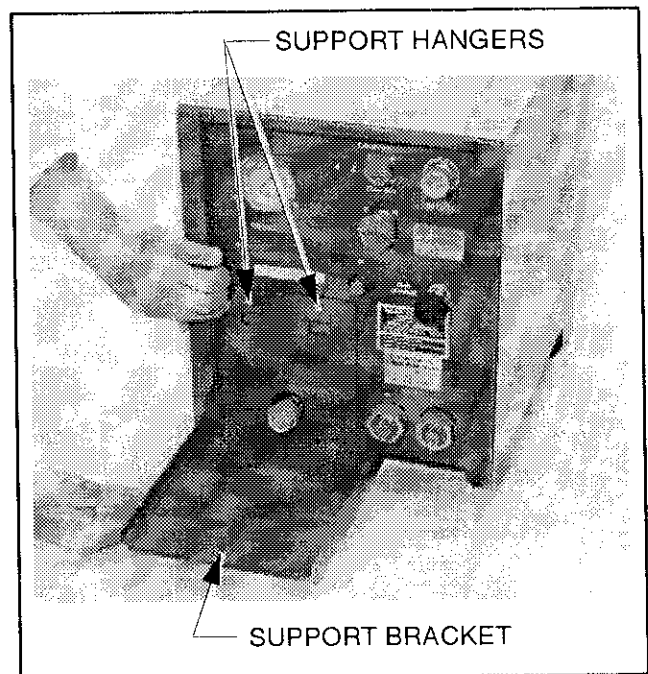

Figure 3.1 Installing cartridge support bracket on compressor

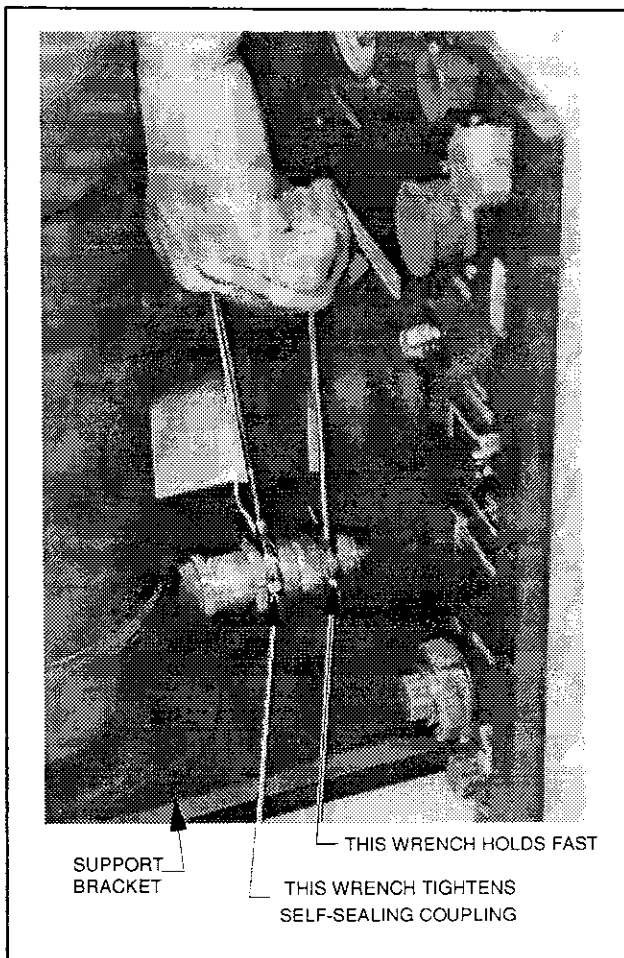

Figure 3.2 Installing the cartridge

CAUTION

Make sure to hold fast on the right coupling nut while tightening the left coupling nut, as shown in Figure 3.2.

5. Secure the cartridge to the support bracket with the cartridge attaching hardware.

3.3 Cooling Water Requirements

Cooling Water: Preparation

1. If flexible water hose connections are used, install the barbed fittings supplied with the compressor on the input and output connections:

- a. Apply a light coating of standard plumbing thread sealant on the barbed fitting threads.
 - b. Tighten fittings onto input and output connections. **DO NOT OVERTIGHTEN.**
 - c. Connect flexible hoses to the fittings and secure with hose clamps.
2. If hard piping is desired, install the water lines directly onto the input and output connections. **DO NOT OVERTIGHTEN.**

CAUTION

Check water connections for leaks.

Cooling Water: General Considerations

For Your Information —

Adjust your water flow to maintain an optimum discharge water temperature of 80°F with a minimum input pressure of 7 psi. For detailed water requirements, see Table 1.1, page 1-2.

Cooling water having a pH value of 6.0 to 8.0 and a calcium-carbonate concentration of less than 75 ppm, the quality of typical municipal drinking water, is acceptable. If the cooling water has a pH value lower than 6.0 or a calcium-carbonate concentration higher than 75 ppm, water conditioning may be required.

1. The cooling water must meet the following flow, pressure, and temperature requirements.
 - Maximum outlet temperature 90°F (32°C).
 - Minimum inlet temperature 40°F (4°C).
 - Maximum inlet pressure 100 psig.

A system with nominal cooling water conditions would have a 70°F water supply, 0.5 gpm, 3.5 psid (pressure drop: water inlet or water outlet). The pressure value does not consider discharge back-pressure conditions.

2. To conserve water, the cooling water should be shut off when the compressor is not running.

CAUTION

If the cooling water below 40°F (4°C) is allowed to run through the compressor while the compressor is not operating, the compressor oil will change viscosity and thicken, causing the compressor to overheat and shut off at startup. In this event, repeatedly restart the compressor and allow it to run until it has shut off several times. The oil temperature will rise and thereby allow continuous compressor operation.

3. Drain and purge water from the compressor before it is shipped or if it is subjected to freezing conditions. Purge water from the compressor by blowing compressed air, regulated to 30 to 40 psig (200 to 275 kPa) into the compressor output connection and allowing water to exit from the water input connections.

3.4 Connecting the Compressor to the Cryopump

For Your Information —

If your application requires the use of multiple compressors on a single gas manifold, you must install an external check valve on the gas-return connector of each compressor. Contact the Applications Engineering Department for installation guidance on manifold-ing compressors.

Make the connections between the compressor and cryopump (See Figure 3.3):

1. Remove all dust plugs and caps from the helium-gas supply and helium-gas return lines, compressor, and cryopump cold head. Check all fittings.
2. Connect the helium-gas return line from the gas-return connector on the compressor to the gas-return connector on the cryopump cold head.
3. Connect the helium-gas supply line from the supply connector on the cartridge to the gas-supply connector on the cryopump cold head.
4. Attach the supply and return line identification decals (CTI-supplied) to their respective connecting piping ends.

Verify proper helium supply static pressure by confirming that the helium pressure gauge reads 245-250 psig (1690-1725 kPa) in an ambient temperature range of 60 to 100°F (16 to 38°C).

If the indicated pressure is higher than 250 psig (1725 kPa), reduce the pressure as follows:

1. Remove the flare cap from the gas charge fitting.
2. Open the gas charge valve very slowly. Allow a slight amount of helium gas to escape until the helium pressure gauge reads 250 psig (1725 kPa).
3. Close the gas charge valve and reinstall the flare cap.

If the indicated pressure is lower than 245 psig (1690 kPa), add helium gas as described in Section 4.2, page 4-3.

3.5 Electrical Connection of Compressor to Connector



WARNING

The switch on the front of the controller must be in the OFF position before making any and all electrical connections.

1. Connect the following electrical cables between the controller and the compressor.
 - a. The compressor control cable between the controller and compressor.
 - b. The compressor power cable to controller and compressor.
2. Check to insure the cold-head power cable is properly connected to the cold-head.
3. Check to insure the controller input power cable is properly connected to the main power source.
4. Your system is now ready to operate.

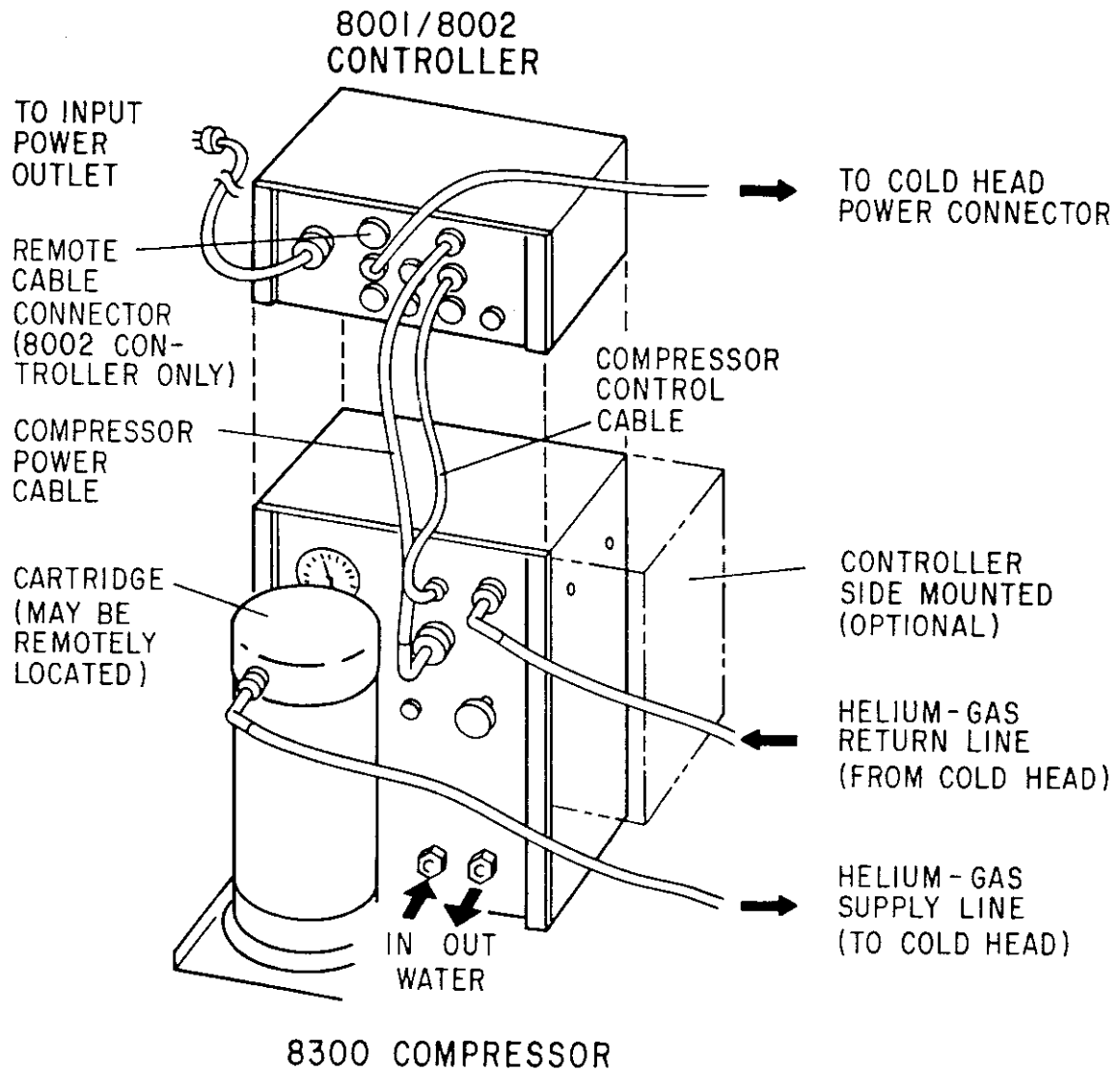



Figure 3.3 Typical component installation setup

Section 4 Maintenance Procedures

4.1 Scheduled Maintenance 4-1
4.2 Unscheduled Maintenance 4-3

	⚠ WARNING
<p>Always disconnect the compressor from all sources of electrical power before performing any maintenance procedures.</p>	

	⚠ WARNING
<p>Depressurize the cartridge before disposing of it. Attach the depressurization fitting (included in the Installation Tool Kit) to the coupling half at either end of the cartridge and tighten it slowly.</p>	

4.1 Scheduled Maintenance

The only scheduled maintenance required on the 8300 Compressor is replacement of the compressor cartridge (P/N 8080280K001) every 12 months. To remove and replace the compressor cartridge proceed as follows:

1. Shut down the compressor by placing the system power switch on the controller to OFF.
2. Disconnect the helium-gas supply line from the gas-supply connector on the cartridge.
3. Remove the cartridge from the compressor according to Figures 4.1 and 4.2. Save all nuts, bolts, and washers for installing the replacement cartridge.

4. Install the replacement cartridge following the steps in Figure 4.2, in reverse order. Use the hardware saved in step 3 above. Reconnect the self-sealing coupling per Figure 3.2, page 3-2.
5. Ensure that the pressure gauge reads 245-250 psig (1690-1725 kPa). If additional gas pressure is required, follow the instructions in Section 4.2, under Adding Helium Gas.
6. Write the date on your log that the cartridge was replaced, and also make a note that the next cartridge replacement is in 12 months.



1. Use two wrenches (supplied) to avoid loosening the body of the coupling from its adapter.
2. Unscrew the two self-sealing coupling halves quickly to minimize gas leakage.

Figure 4.1 Disconnecting the cartridge self-sealing coupling

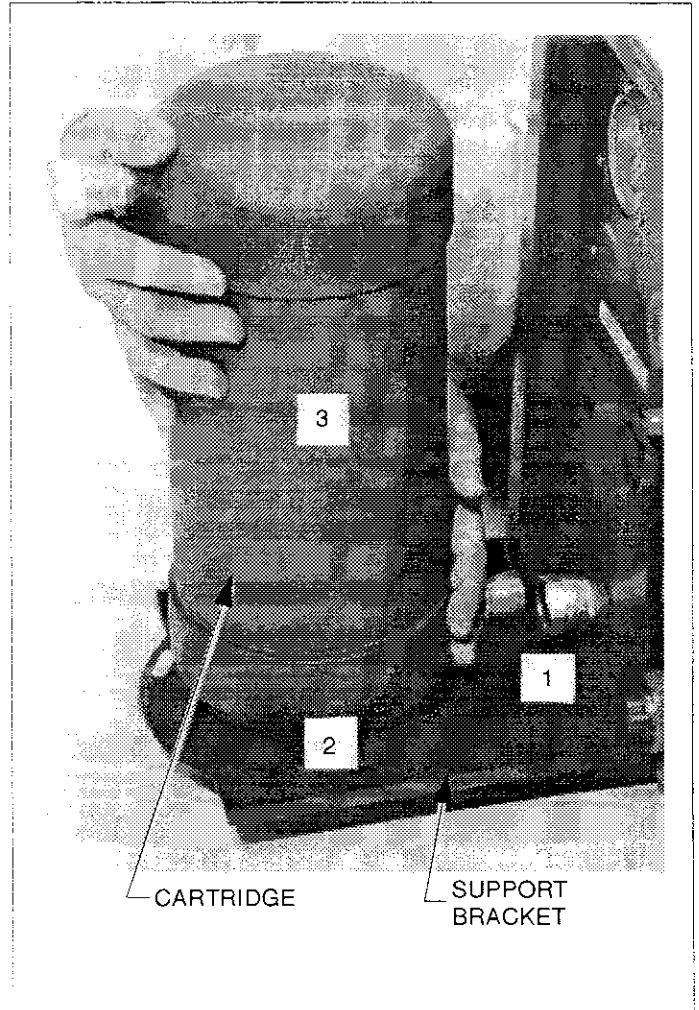

1. Disconnect the cartridge-inlet self-sealing coupling. See also Figure 4.1.
2. Remove the bolts, nuts, and washers that secure the cartridge to the support bracket.
3. Carefully lift the cartridge and remove it from the support bracket.

Figure 4.2 Removing the cartridge from the compressor

4.2 Unscheduled Maintenance

Suggested Maintenance Equipment

It is advisable to have available the equipment and disposable supplies listed below.

1. Helium, 99.999% pure.
2. Indium gasket 0.005-inch thick, 3" x 3" sheet, P/N 3543738P001.
3. Maintenance manifold, P/N 8080250K003*.
4. Pressure regulator (0-3000/0-400 psig).
5. Helium charging line terminating in a 1/4-inch female flare fitting (P/N 7021002P001).
6. Installation Tool Kit, P/N 8032040G013 or P/N 8052069G005 for ON-BOARD 8/8F. Supplied with high-vacuum pump.
7. Lint-free gloves and cloth.
8. Oakite or equivalent detergent soap.
9. Denatured alcohol.
10. Apiezon™ vacuum grease, P/N 579847*.
11. Torque wrench, 0 to 30 inch-pounds.

*Available from stock; consult the factory or your sales representative.

Table 4.1 Typical Pressure Variations During Normal Operation (CT-100, 7, 8, 8F, and ON-BOARD 8/8F)

CRYOPUMP (NO. USED)	HELIUM RETURN PRESSURE PSIG (kPa)*
CT-100 (1) CT-100 (2)	95 (655) 115 (790)
CT-7 (1)	95 (655)
CT-8 (1)	105 (725)
CT-8F (1)	105 (725)
ON-BOARD 8/8F (1)	105 (725)

*Center point of needle swing.

Adding Helium Gas

CAUTION

If the compressor helium pressure gauge reads 0, decontamination is required. Refer to decontamination procedures on page 4-4 or contact the Product Service Department.

There are two conditions that require the addition of helium gas:

1. Compressor not operating; helium pressure gauge reads 245 psig (1690), or below.
2. Compressor operating; helium pressure reads below that specified in Table 4.1.

If you need to add helium more than once every several months, check for leaks caused by improperly connected self-sealing connections or any mechanical joint within the compressor.

A User-supplied helium charging line terminating in a 1/4-inch female flare fitting, and a two-stage pressure regulator rated at 0-3000/0-400 psig is required for this operation.

Use only 99.999% pure helium gas.

To add helium gas:

1. Attach a two-stage regulator (0-3000/0-400 psig) and charging line to a helium bottle (99.999% pure). **DO NOT OPEN THE BOTTLE AT THIS TIME.** Purge the regulator and charging lines as instructed in steps a through d below. Do *not* use helium gas that is *less than 99.999% pure*.
 - a. Open the regulator a small amount by turning the adjusting knob clockwise until it contacts the diaphragm, then turn approximately 1/8 to 1/4 turn more, so that the regulator is barely open.
 - b. Slowly open the bottle valve, and purge the regulator and line for 10 to 15 seconds. Turn the regulator knob counterclockwise until the helium stops flowing.

- c. Loosely connect the charge line to the helium pressure regulator.
- d. Purge the charge line again, as in step a, for 30 seconds, and tighten the charge line flare fitting onto the helium pressure regulator while the helium is flowing.

The procedure is required to ensure that both the regulator and the charging line will be purged of air and that the air trapped in the regulator will not diffuse back into the helium bottle. For best results, CTI suggests a dedicated helium bottle, regulator, and line, which are never separated, for adding helium.

2. Remove the flare cap of the gas charge fitting on the rear of the compressor.
3. Attach the charging line from the helium pressure regulator to the 1/4-inch male flare fitting installed on the helium charge valve.
4. Set the helium pressure regulator to 300 psig (2070 kPa). Depending on the compressor operating state, add helium gas:
 - a. If the compressor is running under normal operating conditions, slowly open the helium charge valve on the rear of the compressor. When the helium pressure gauge rises to that specified in Table 4.1, tightly close the charge valve.
 - b. If the compressor is not running, slowly open the helium charge valve. When the helium pressure gauge rises to 245-250 psig (1690-1725 kPa), tightly close the charge valve.
5. Ensure that the helium charge valve on the compressor is tightly closed. Shut off the helium pressure regulator on the helium bottle and remove the charging line from the male flare fitting. Reinstall the flare cap.

Helium Circuit Decontamination

Contamination of the helium-gas circuit is indicated by sluggish or intermittent operation (ratchetting) of the cold head drive mechanism. With severe contamination the cold head drive may seize and fail to operate. One of the major sources of contamination is using helium gas of less than the required purity. When performing the decontamination process, use only 99.999% pure-helium gas, and the regulator and charging line must be properly connected and purged. This decontamination procedure will remove contaminants from the cold-head and/or compressor, thereby restoring system performance. The cold-trapping of contaminants inside the cold head during this procedure will also decontaminate the compressor if the contamination of the system is not severe. Separate decontamination of the compressor is required whenever the compressor has been opened to atmosphere, or the pressure dropped to zero.

Cryopump Decontamination Procedures

1. Cool down the cryopump and operate it for one to three hours. If the system will not cool down, proceed to step 2. Operating the cryopump will isolate the contaminants by "freezing" them in the cold head. The contaminants in the helium-gas circuit of the cryopump tend to become frozen inside the cold head. The longer the cryopump is operated beyond the one-hour period, the greater is the amount of contamination that becomes isolated inside the cold head.
2. Shut down the compressor as follows:
 - a. Close the Hi-Vac valve in your vacuum system.
 - b. Turn off the system power ON/OFF switch on the controller.
 - c. Immediately start purge gas flow.

- d. Allow the cryopump to warm up to ambient temperature without exposing it to the atmosphere. Warmup may take as long as 2 1/2 hours if no heat load is present.

⚠ CAUTION

Exposing the cryopump to atmosphere during warm-up will cause excessive water vapor adsorption by the charcoal of the 15K array.

- 3. **Immediately** disconnect the helium-gas supply and helium-gas return lines from the gas-supply and gas-return connectors at the rear of the compressor. Leave them attached to the cold head.
- 4. Attach the maintenance manifold (P/N 8080250K003) to the disconnected ends of the helium-gas return and helium-gas supply lines.
- 5. Reduce the pressure in the cold head to a level of 45 psig by using the maintenance manifold.
- 6. Allow the second stage of the cold head to warm up to room temperature. Warmup time can be reduced by purging the cryopump with warm dry argon or nitrogen gas. Using the gas heater, CTI P/N 8080250K020, will reduce warm-up time about 50 percent, and will maintain the gas temperature below the 150°F (66°C) limit.
- 7. Once the cryopump has reached room temperature, attach a two-stage regulator (0-3000/0-400 psig) and charging line to a helium bottle (99.999% pure). **DO NOT OPEN THE BOTTLE VALVE AT THIS TIME.** Purge the regulator and charging line as instructed in steps a through d below. Do not use helium gas that is *less than 99.999% pure*.
 - a. Open the regulator a small amount by turning the adjusting knob clockwise until it contacts the diaphragm; then turn approximately 1/8 to 1/4 turn more, so that the regulator is barely open.
 - b. Slowly open the bottle valve, and purge the regulator and line for 10 to 15 seconds. Turn the regulator knob counterclockwise until the helium stops flowing.

- c. Loosely connect the charge line to the 1/8-inch Hoke valve on the maintenance manifold.
- d. Purge the charge line again, as in step a, for 30 seconds, and tighten the charge line flare fitting onto the valve while the helium is flowing.

This procedure is required to ensure that both the regulator and the charging line will be purged of air. For best results, CTI suggests a dedicated helium bottle, regulator, and line, which are never separated, for adding helium.

- 8. Perform in sequence:
 - a. Backfill the cold head with helium to a static charge pressure of 245-250 psig (1690-1725 kPa), by adjusting the regulator to the required pressure, and opening the valve on the manifold. Close the valve when the pressure is correct.
 - b. Depressurize the cold head by *slowly* opening the ball valve and allowing the helium to bleed out slowly. Do *not* reduce the pressure to *less than* 30 psig or the cold head may be further contaminated.
 - c. Perform flushing steps a and b four more times.
 - d. Pressurize the cold head to the static charge pressure of 245-250 psig (1690-1725 kPa), and run the cold head drive motor for 10 to 30 seconds by actuating the controller ON/OFF switch.
 - e. Perform steps b through d four more times for a total of 20 flushes and a total of 4 drive-motor runs.
- 9. Verify that the cold head is pressurized to the static charge pressure of 245-250 psig (1690-1725 kPa).
- 10. Disconnect the maintenance manifold from the helium-gas return and helium-gas supply lines.
- 11. Reconnect the helium-gas return and helium-gas supply lines to the return and supply connectors at the rear of the compressor. The cryopump is now ready for operation.

Compressor Decontamination Procedures

The procedure to decontaminate a compressor is similar to the above procedure with certain exceptions.

- There is no need to operate the cryopump before decontaminating the compressor.
 - The maintenance manifold and helium-gas supply and helium-gas return lines will be connected to the supply and return fittings on the compressor.
1. Depressurize the compressor (if pressurized) to 30 psig by slowly opening the ball valve on the maintenance manifold and allowing the helium to bleed out.
 2. Charge the compressor slowly to approximately 250 psig (1725 kPa) by opening the 1/8-inch valve on the maintenance manifold.

3. Run the compressor for about 30 seconds.
4. Repeat steps 1 and 2, one more time.
5. Disconnect the maintenance manifold from the helium-gas return and helium-gas supply lines.
6. Reconnect the helium-gas return and helium-gas supply lines to the return and supply connectors on the cold head. The compressor is now ready for operation.

For Your Information —

After connecting the compressor to the cryopump, and operating the system for a period of time, it may be necessary to decontaminate the cryopump as some residual contamination from the compressor may become trapped in the cold head. If the entire system were reduced to zero psig (a broken flex line for example), then the cryopump and compressor would have to be decontaminated according to the cryopump decontamination section, beginning on page 4-4.

Appendix A

Troubleshooting Procedures

A.1 Troubleshooting the Compressor A-1
A.2 Technical Inquiries A-1

A.1 Troubleshooting the Compressor

The compressor troubleshooting procedures are summarized in Table A.1.

A.2 Technical Inquiries

Please refer to page ii of this manual for a complete list of the CTI-CRYOGENICS' world wide customer support centers.

Table A.1 Troubleshooting the Compressor

	⚠ WARNING
<p>1. Disconnect the controller power before performing any troubleshooting procedures.</p> <p>2. The compressor pump is hot after operating. Wait for the pump to cool down before working on the inside of the compressor.</p>	

Problem	Possible Cause	Corrective Action
1) Compressor power ON/OFF switch (S1) located on the controller remains on but the compressor will not run.	1) Low voltage from power source.	1) Check source fuses, circuit breakers, etc. Confirm power source voltage between 180 and 250 volts is constant and steady.
	2) Circuit breaker has tripped.	2) Push reset button on rear of controller.
2) Compressor stops after several minutes of operation and remains off. (Compressor power indicator lamp is off.)	1) Insufficient helium pressure as indicated by the return pressure gauge.	1) Add helium per Section 4.2, page 4-3.
	2) Thermal overload switch (TS1 or TS2) open. (The compressor will not restart after the controller circuit breaker is reset; wait 2 to 3 minutes before restarting.)	2) Check for inadequate water cooling see Table 1.1. Allow 10 minutes for switch to cool, then restart compressor.
	3) Improper voltage to system.	3) Check for proper voltage from power source. Refer to Table 1.1, page 1-2 of the Controller Manual for voltage requirements.
	4) Mechanical seizure.	4) Contact the Product Service Department.

Appendix B

Electrical Schematic for 8300 Compressor

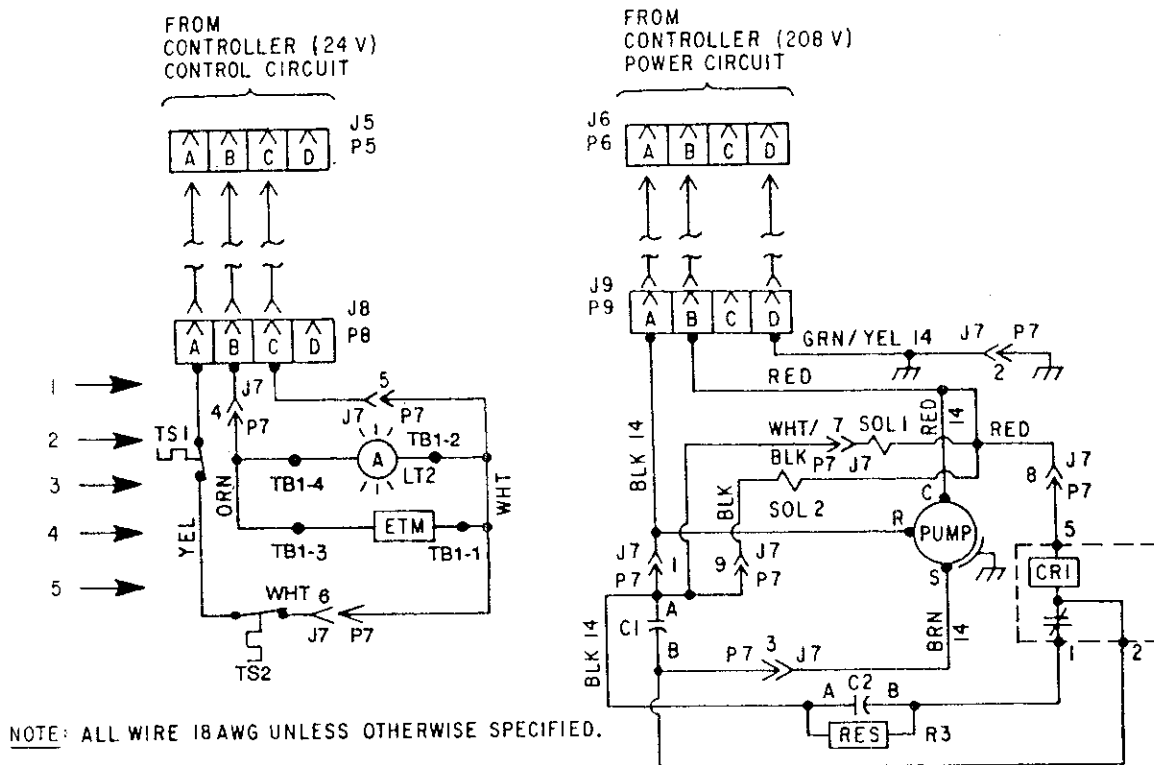

COMPRESSOR

- | | |
|--|--|
| C1 - Compressor Run Capacitor,
35 μ f, 370 VAC | LT2 - Compressor Status Indicator Lamp |
| C2 - Compressor Start Capacitor,
108-130 μ f, 330 VAC | R3 - Resistor - 150K Ω , 2W |
| CR1 - Compressor Starting Relay | SOL1 - Solenoid Valve - Gas Flow |
| ETM - Elapsed Time Meter | SOL2 - Solenoid Valve - Oil Flow |
| J7 - Compressor Harness Internal Connector | TB1 - Terminal Board |
| J8 - Compressor Control Connector | TS1 - Thermal Protective Switch - Water Flow |
| J9 - Compressor Power Connector | TS2 - Thermal Protective Switch |

Figure B.1 Electrical schematic for 8300 Compressor
Drawing No. 8052203 Rev. A

Appendix C

Flow Diagram for 8300 Compressor

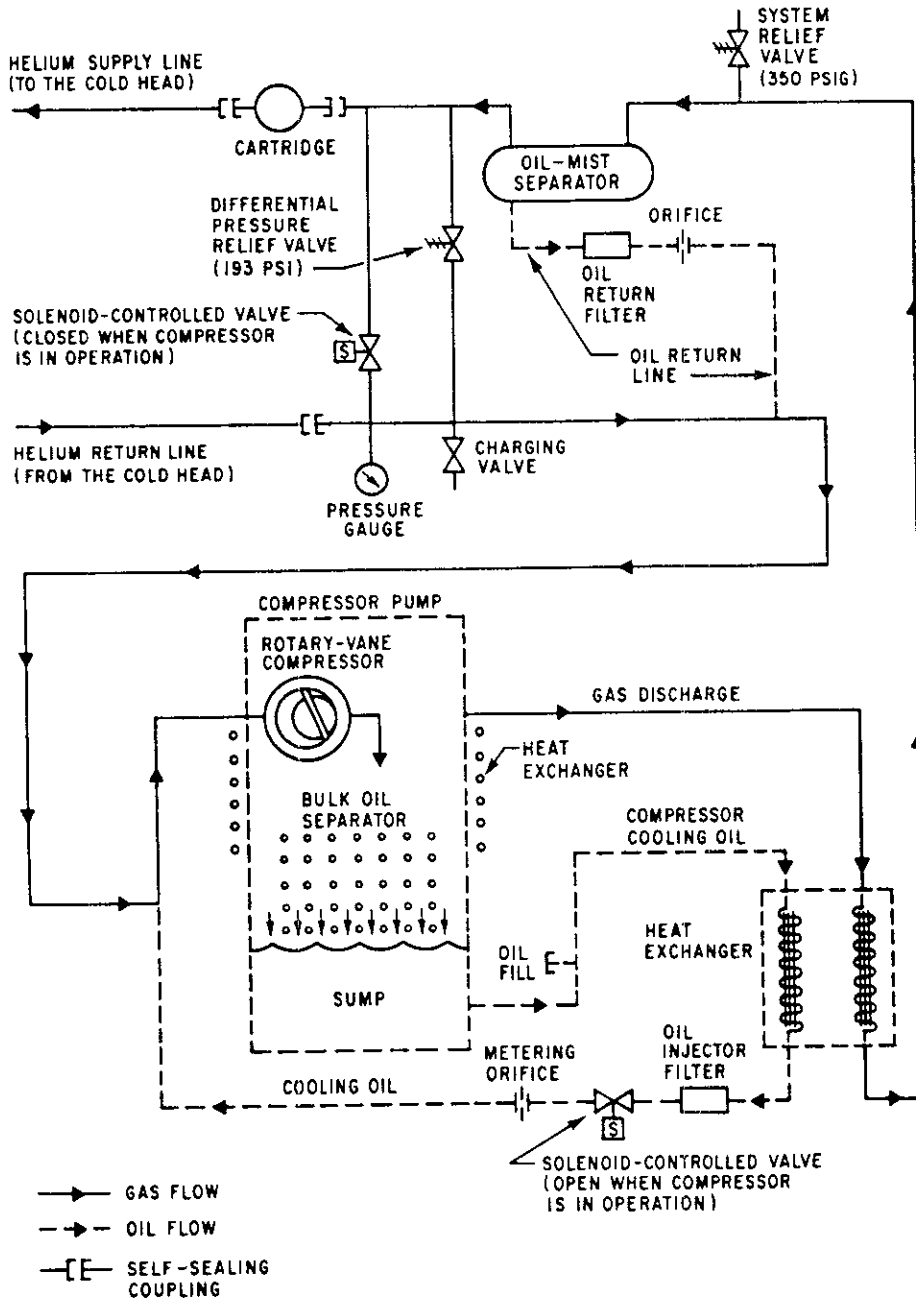

Figure C.1 Flow diagram for the 8300 Compressor

This page intentionally left blank.