



# ATH 500 M/MT

Magnetically levitated turbopumps

## Operating instructions

---

# ATH 500 M-MT

## Magnetically levitated turbo pumps

### Welcome

Dear Customer,

You have just purchased an adixen magnetically levitated turbo pump. We would like to thank you and are proud to count you as one of our customers.

This product has benefited from adixen Vacuum Products many years of experience in the field of turbomolecular pump design.



**This pumping component is designed to generate vacuum by pumping on gases, but no liquids neither solids. It is dedicated for running in industrial environments.**

**The integrator of this component must provide all operator safety measures mainly against hot surfaces.**

**This pumping component must not operate in an area with risk of explosion. Consult us to study a solution.**

#### APPLICATIONS:

SEMICONDUCTOR APPLICATIONS : plasma etching, Ion implantation, sputtering, plasma deposition.

OTHER APPLICATIONS: research and development, high energy physics, space simulation, accelerators.

OTHER INDUSTRIES: glass-coating, flat panel display, leds, deposition coating, hard disk manufacturing.

#### ADVANTAGES:

High throughput - Quiet and clean vacuum - Corrosion proof - High MTBF - Minimum size, volume and weight - Smart and compact electronic controller - Reliability - Maintenance free - Battery free - Easy integration.

**In order to ensure the best possible performance of the equipment and your complete satisfaction in using it, we advise you to read this manual carefully before any intervention on your pump and to pay particular attention to the equipment installation and start-up section.**

---

# **ATH 500 M-MT**

## **Magnetically levitated turbo pumps**

**This product complies with the requirements of European Directives, listed in the Declaration of Conformity contained in G 100 of this Manual.**

**Copyright/Intellectual property:**

**The use of adixen products are subject to copyright and intellectual property rights in force in any jurisdiction.**

**All rights reserved, including copying this document in whole or any part without prior written authorization from adixen Vacuum Products.**

**Specifications and information are subject to change without notice by adixen Vacuum Products.**

# General contents

---

## ATH 500 M-MT Operating instructions

*Translated from  
original version*

### Chapter A

### INTRODUCTION

- A 150 - Introduction to the ATH 500 M-MT
- A 200 - Control loop of the pump
- A 210 - The pump operating principle
- A 400 - The technical characteristics
- A 510 - The accessories of the pump

### Chapter B

### START-UP

- B 100 - Safety instructions for installation
- B 201 - Unpacking and storage of the controller
- B 300 - Pump connections to an installation
- B 310 - Inlet connections
- B 330 - Nitrogen connection on the purge port
- B 333 - Assembly of the purge kit
- B 340 - Water cooling connection
- B 350 - Air cooling connection
- B 400 - Safety instructions and electrical connections
- B 430 - «Remote control» connection wiring
- B 450 - RS 232 or RS 485 link wiring

### Chapter C

### OPERATION

- C 100 - Safety instructions for product use
- C 200 - The front panel with operating status
- C 300 - Configuring the ATH500 M-MT pump for the application
- C 800 - Detailed description of RS232 and RS485 commands

### Chapter D

### MAINTENANCE

- D 100 - Safety instructions for product maintenance
- D 150 - Maintenance frequency
- D 200 - Diagnosis and troubleshooting

### Chapter E

### MAINTENANCE INSTRUCTIONS

- E 100 - Shipping procedure for contaminated pumps

### Chapter F

### MAINTENANCE COMPONENTS

- F 000 - Spare parts - Instructions of use
- F 200 - First level maintenance parts

### Chapter G

### APPENDIX

- G 100 - Declaration of conformity
- G 150 - Pumping curves
- G 200 - Safety Questionnaire
- G 1000 - Hand Held Remote (HHR)

# General contents

## ATH 500 M-MT Operating instructions

*Translated from  
original version*

### **CAUTION**

Indicates a potentially hazardous situation which, if not avoided, could result in property damage.

### **⚠ CAUTION**

Indicates a potentially hazardous situation which, if not avoided, could result in moderate or minor injury. It may also be used to alert against unsafe practices.

### **⚠ WARNING**

Indicates a potentially hazardous situation which, if not avoided, could result in death or severe injury.

### **⚠ DANGER**

Indicated an imminently hazardous situation that, if not avoided, will result in death or severe injury (extreme situations).











Before switching on the appliance, study the user's manual and make sure you follow the safety instructions it gives. You can recognise these by the 'Caution', 'Warning' and 'Danger' symbols.  
Good practice tips and manufacturer's recommendations are in a blue box.

The performance and operational safety of this product are guaranteed provided it is used normally in the operating conditions defined in this manual. It is the customer's task to:

- train operators to use the product if they do not speak the language the manual is written in,
- ensure operators know the safe practices to apply when using the product.

## ATH 500 M-MT Operating instructions

*Translated from  
original version*

Symbols, labels	Description
	Warning : hot surface
	Warning : hazardous voltage
	Caution : risk of danger. Refer to the operating instructions before use
	Operating status
48 V  12 A	Power supply
	Do not touch when the pump is running
	Use of glove is recommended
	Moving parts present
	Heavy object
	Lock the electrical connector before using the pump and during operation
<b>Purge</b>	Purge port
<b>Pump exhaust</b>	Exhaust of the pump
<b>Water</b>	Water cooling circuit connection
<b>Water max Pr.7 bar/101 psi</b>	Max. cooling water pressure
<b>PWR</b>	Pump power on
	Direction of rotation of the pump



# Introduction

## ATH 500 M-MT User's Manual Detailed contents

A 150

*Introduction to the ATH 500 M-MT*

A 200

*Control loop of the pump*

- 5 active axis
- Unbalanced force rejection control

A 210

*The pump operating principle*

- Pumping principle
- The hybrid-turbo pump in an installation
- The back-up bearings
- Variation of the pump rotational speed

A 400

*The technical characteristics*

- The performances of the pump
- The technical characteristics of the electronic
- The dimensions

A 510

*The accessories of the pump*

---

## Introduction to the ATH 500 M-MT

**A magnetically  
levitated hybrid  
turbo pump**



### **ATH 500 M with integrated electronic**

**Five active axes**

Rotor position control in 5 directions.

**Unbalanced force rejection control**

Lowest possible levels of noise and vibration.  
Compensation for any unbalance of the rotor.

**Maintenance free**

**Inert gas purge**

Eliminate corrosion of the motor and magnetic bearing coils.

**Battery free**

In case of a power failure, the pump motor acts like a generator to transform the rotor energy into electrical power to supply the electronic.

Electrical power supply 48 V DC (accessory)  A 510.



## Introduction to the ATH 500 M-MT

### ATH 500 M Model

For OEM version, see its own specific technical sheet.

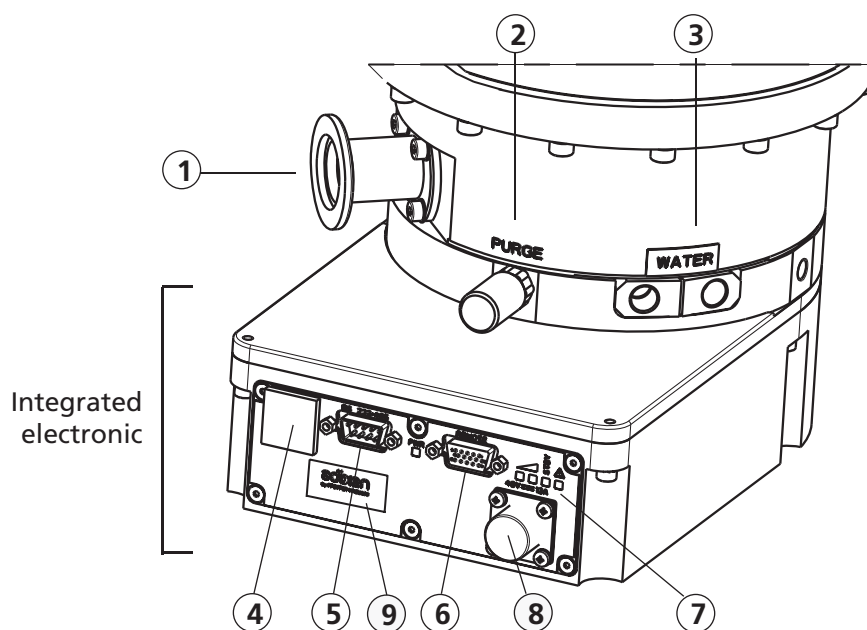



①	Exhaust port	DN25 ISO KF
②	Integrated purge (50 sccm)	1/8 "BSPP female equipped with a filter 📖 B 330
③	Water fittings	1/8 NPT female 📖 B 340
④	Service	Used by service and HHR.
⑤	RS232 or RS485 serial links	The serial link RS 232 or RS 485 is used to monitor and control the pump from a computer. The serial link RS 485 allows the installation and the control of many pumps in a network. 📖 B 450 and C 800
⑥	Remote connector	The remote control connector is used for the remote control of START/STOP/STANDBY functions to allow the copy of pump status via dry contact outputs. 📖 B 430
⑦	Pump status indicator lights	📖 C 200
⑧	Power supply connector	Used to plug a 48 VDC power supply 📖 B 400
⑨	Profibus- Devicenet connectors	Industrial network connectors and indicator areas (Profibus - Devicenet)

## Introduction to the ATH 500 M-MT

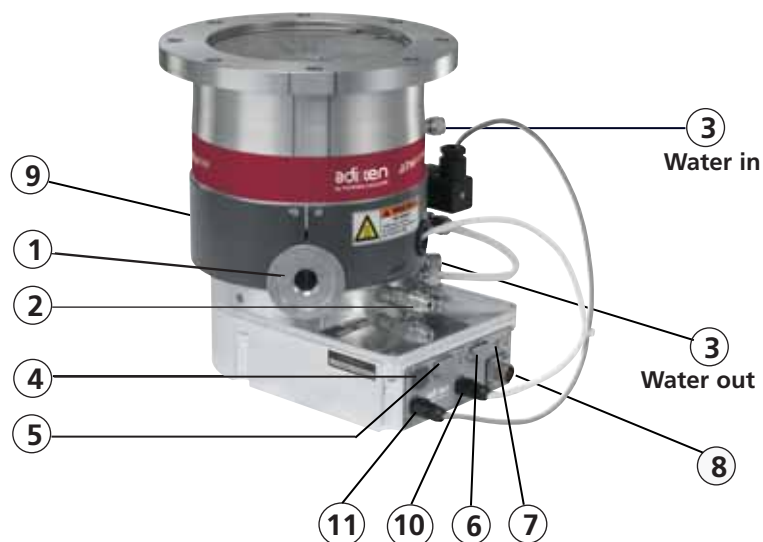
### ATH 500 MT Model



①	Exhaust port	DN40 ISO KF
②	Integrated purge (50 sccm)	1/4 VCR  B 330
③	Water fittings	1/4 double ring  B 340
④	Service	Idem ATH 500 M
⑤	RS232 or RS485 serial links	Idem ATH 500 M
⑥	Remote connector	Idem ATH 500 M
⑦	Pump status indicator lights	Idem ATH 500 M
⑧	Power supply connector	Idem ATH 500 M
⑨	Heater band	The heating band keeps the inner surface of the pump up to 65 °C to avoid condensation effects. The temperature is controlled by the controller.
⑩	Supply heater band	Connect the heater band to the controller
⑪	Supply water valve	Connect the water valve to the controller

## Introduction to the ATH 500 M-MT

### Air cooled ATH 500 M Model

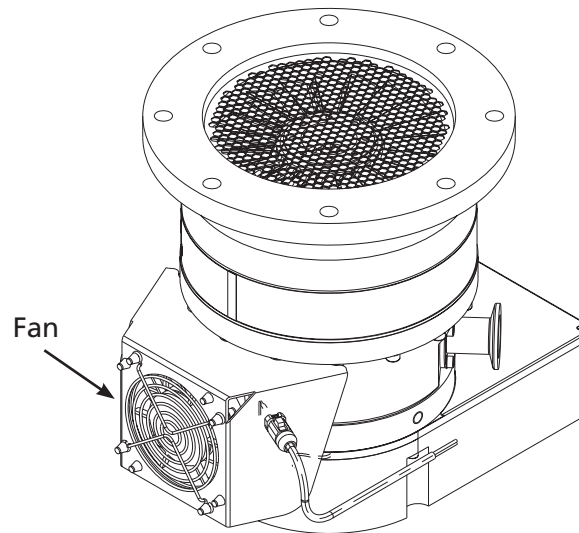

The fan must be supplied by an external power supply 48 VDC, either ordered as an accessory (  **A510**), or provided by the customer.

## Control loop of the pump

**5 active axis** The mobile assembly formed by the turbo rotor and the shaft is known as the rotor. The rotor is driven by the motor and held in suspension by magnetic fields generated by electromagnets housed in an active bearing.

The mobile rotor has 5 axes of freedom monitored by 5 active magnetic bearings.

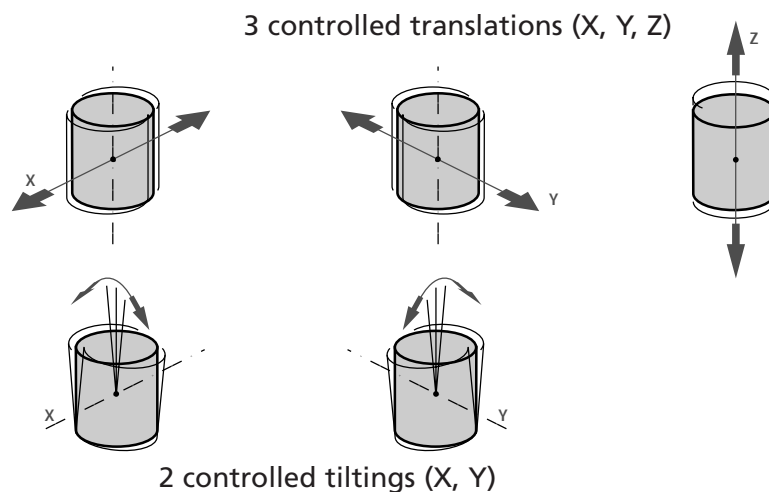

Movements in relation to these axes are monitored by position sensors. According to the position data recorded, the controller corrects differences to bring the rotor back to its optimum position, by varying the current in electro-magnets.

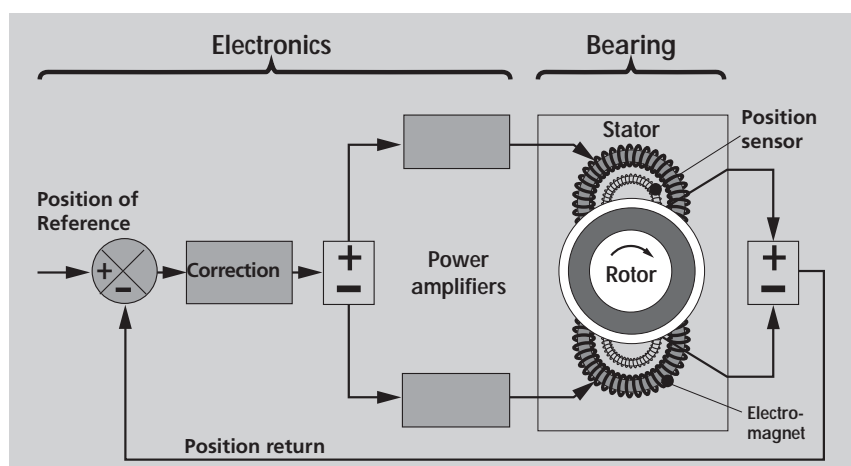

---

## Control loop of the pump

### Unbalanced force rejection control

The **unbalanced force rejection control** is an electronic function, that monitors the rotor position, allowing it to rotate in its own axis of inertia.

Changes in the rotor balance, due to deposit built-up during the life time of the pump, are automatically compensated by the **unbalanced force rejection control**.

It ensures the lowest possible levels of noise and vibration.

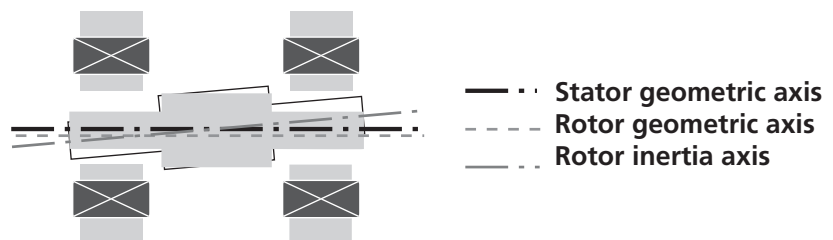

## The pump operating principle

### Pumping principle

The ATH 500 M pump integrates the advantages of a multi-staged turbomolecular pump with a spiral helix molecular drag section.

The turbomolecular section provides high pumping speeds and high ultimate vacuum. The molecular drag section provides a high compression ratio and extends the forevacuum tolerance up to the range of mbar.

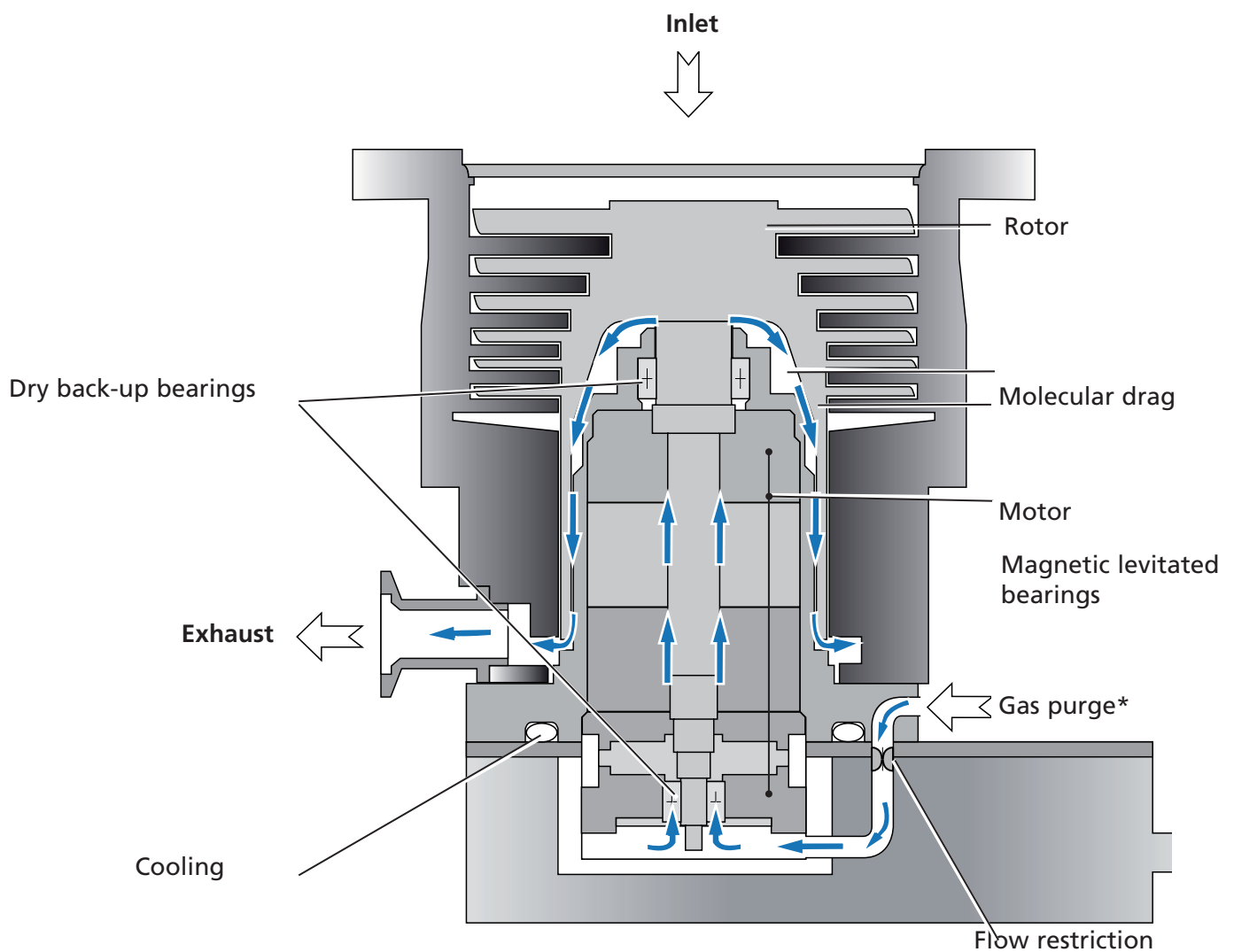

\* The gas purge provides an excellent protection for corrosive applications and the rotor cooling.

## The pump operating principle

### The hybrid-turbo pump in an installation

At the pump exhaust, the gases are evacuated to atmosphere by a primary pump. The ATHM compression ratio is set by the design. The pumping performances depend on the primary pump and on the installation.

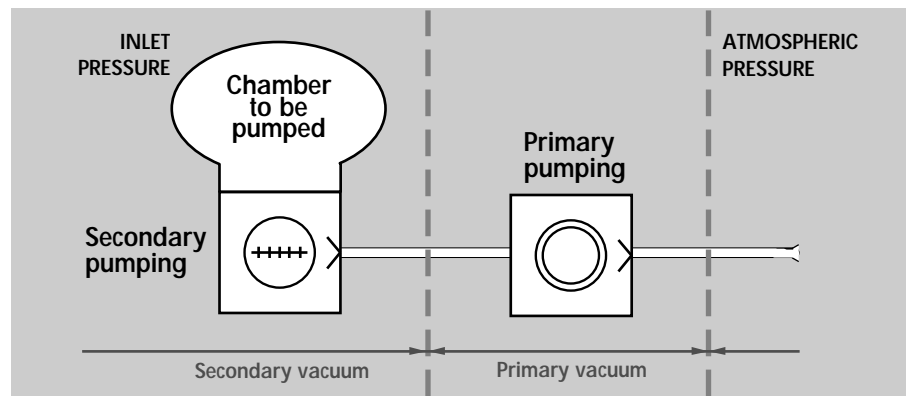

---

## The pump operating principle

### The back-up ball bearings

They are dry-lubricated ball bearings.

**They are never used in normal operation**, since the rotor is not in contact with the ball bearings.

**The back-up bearings are only used to protect the pump in accidental air in-rushes, accidental shocks or power failure.**

### No maintenance

By design, the pump doesn't include parts liable to wear and doesn't need preventive maintenance. However, the back-up ball bearings used in case of accidental shut-downs have to be changed when the controller indicates it: the percentage of landing time to be deducted depends on the number of incidents. For maximum life time of the rotors, see (  **D 150**).

### Battery free

In case of a power failure, the motor acts like a generator, supplying enough power for the magnetic bearings.

When the rotation speed is too low, the pump shuts down and lands on the back-up ball bearings.

### Variation of the pump rotational speed

The ATHM pump rotation speed can be selected and set between a minimum speed and the maximum speed. This makes it possible to optimize pumping characteristics according to each customer application (for example, high pressure pumping (  **A 400**)).

A distinction is made between the following speeds:

- **reduced speed (STANDBY speed)** which can be set between the low speed value and the maximum speed.
- **nominal speed** preselected at factory.



## Technical characteristics of the pumps

### The performances of the pumps

Characteristics		UNITS	ATH 500 M		ATH500MT
Flange (in)			DN 100 ISO-F	DN 160 ISO-F	DN 160 ISO-F
Flange (out)			DN 25 ISO-KF		DN 40 ISO-KF
N2 purge flange			1/8 BSPP (ISO 228)		1/4VCR
Rotation speed		rpm	50000		
Standby speed		rpm (Hz)	15 000 (250) to 50 000 (833)		
Pumping speed *	N2	l/s	330	520	
	Ar	l/s	300	500	
	He	l/s	280	350	
	H2	l/s	170	190	
Compression ratio (ISO 5302)	N2		2x10 <sup>7</sup>		
	Ar		8x10 <sup>6</sup>		
	He		1x10 <sup>4</sup>		
	H2		2x10 <sup>2</sup>		
Inlet vacuum max <sup>(3)</sup>	N2	mbar	1	0.04	
	Ar	mbar	1.0	0,02	
	He	mbar	10	> 0.1	
	H2	mbar	10	> 0.1	
Gas throughput <sup>(3) **</sup>	N2	SCCM	4000	500	
	Ar	SCCM	2500	300	
	He	SCCM	> 10000	> 1000	
	He	SCCM	> 10000	> 1000	
Maximum continuous exhaust pressure <sup>(4)</sup>	N2	Torr/mbar	1,28/1,7	1,35/1,8	1,28/1,7
Maximum permanent premissible exhaust pressure <sup>(4)</sup>	N2	Torr/mbar	3,5/4,65		1,28/1,7
Maximum heating temperature		°C	N/A		65
Leaktightness		mbar/l/s	<5.10 <sup>-8</sup>		
Ultimate pressure <sup>(1)</sup>		Torr/mbar	< 1.10 <sup>-8</sup>		
Maximum baking temperature		°C	120		
Recommended purge flow rate		SCCM	50		
Sound level : EN ISO 2151 (1m distance) at nominal speed		dBA	< 42		
Vibration level at nominal speed		µm	< 0.01		
Mounting orientation			Any		
Pump Protection Index			better than IP 42		

<sup>(1)</sup> With ISO-K, ISO-F flange, better with CF-F flange.

<sup>(3)</sup> With a low exhaust pressure, depends on external conditions of water temperature, water flow, environment temperature.

<sup>(4)</sup> Reduced max. flow, ultimate pressure without flow speed loss ; depends on environment conditions.

\* Without inlet screen

\*\* At full rotational speed (cold for M, at 65°C for MT) water temperature = 25 °C

## Technical characteristics of the pumps

### The performances of the pumps

Characteristics	UNITS	ATH 500 M	ATH500MT
Run-up TIME	mn	< 2.0	
Power consumption max. starting up power	watt	560	
Nominal power	watt	100	
Standby power	watt	< 50	
Controller power supply		48 VDC	
Maximum leakage current	mA	not applicable ; polarity connected to the earth	
Recommanded cooling water flow rate	l/hour	60	
Maximum water line pressure	bar	7	
Cooling water temperature <sup>(5)</sup>	°C	15 - 25	
OBC (on-board-control) control option	Profibus	in option	no
	Remote	yes	
	Devicenet	no	
Weight	kg (lb)	17 (37)	18(39)
Recommended backing pump		ACP 40	
Air cooling	option	yes	no
<b>Environmental conditions :</b>			
• Use of the product	-	Indoor only	
• Ambient operating temperature	°C	5 < T < 45	
• Maximum altitude	m/ft	2000/6562	
• Transient overvoltages typically present on the mains supply	-	Category II	
• Pollution degree applicable	-	2	
• Maximum relative humidity	-	Maximum relative humidity of 80 % for temperature until 31°C with a linear decrease until 50 % relative humidity at 40°C	
• Accept temporary overvoltages on the power line			
<b>Three phase motor characteristics (Max. values) :</b>			
• Voltage between phases	Vrms	29	
• Supply frequency	Hz	1666	
• Phase current	A	9.5	

(5) > 25 °C : apply a derating. Change the operating conditions to reduce the nominal power. Contact the Customer Service.  
Value for pump and controller. Not all the leakage current is necessary evacuated through the earth wire; it depends on the pump earth connection regarding the equipment to which the pump is connected.

# A 400

## Technical characteristics of the pumps

### Dimensions mm (inch) ATH 500M

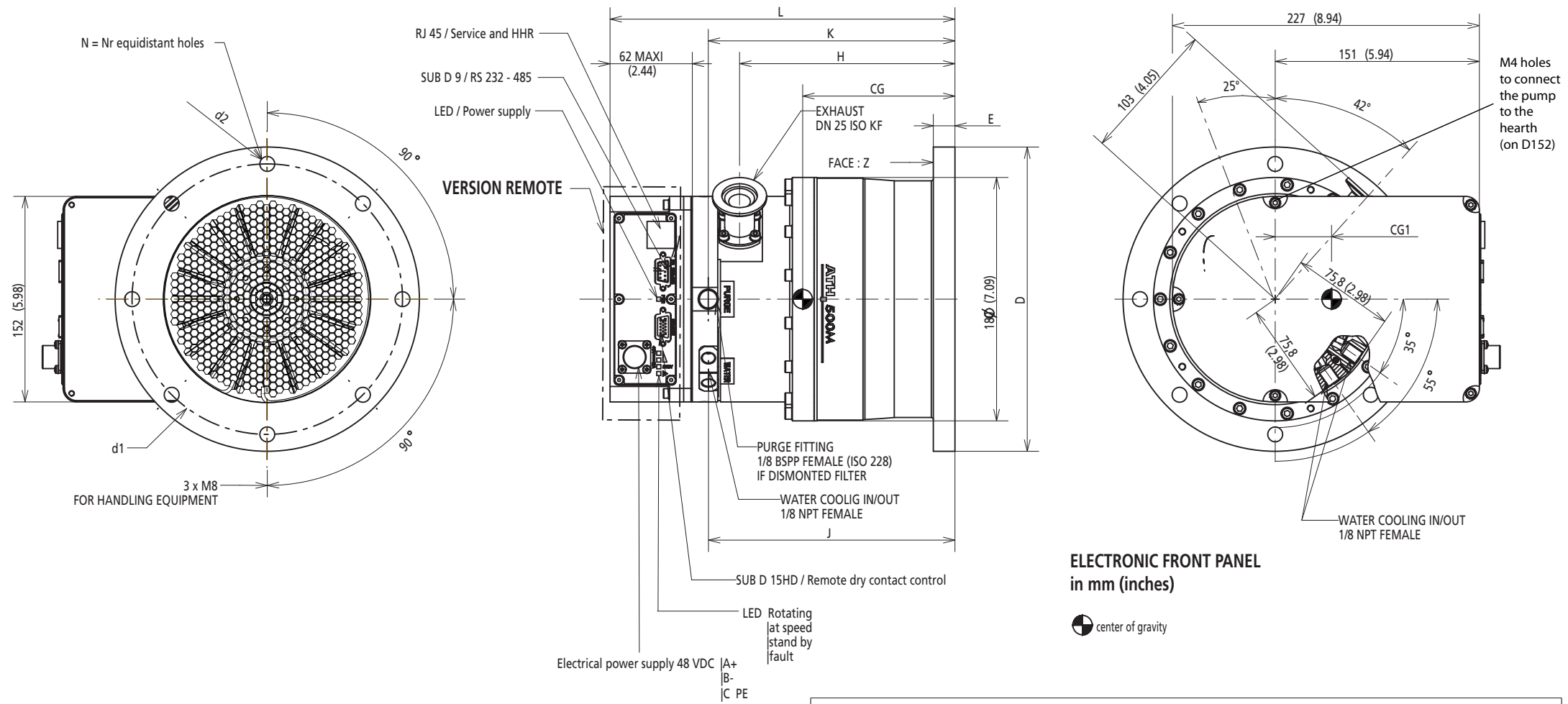

Inlet flange		E	H	J	K	L	D	d1	d2	N	CG	CG1
DN 160 ISO F	mm	16	159.3	182.5	182.2	254.9	225	200	11	8	112.6	9.7
	inch	0.63	6.27	7.18	7.17	9.94	8.86	7.87	0.43	-	4.43	0.38
DN 160 ISO K	mm	12	159.3	182.5	182.2	254.9	180	-	-	-	128.6	11.3
	inch	0.47	6.27	7.18	7.17	9.94	7.09	-	-	-	5.06	0.44
DN 160 CF-F	mm	20	180.3	203.5	203.2	275.9	198	181.1	8.6	20	114.1	10.1
	inch	0.79	7.1	8.01	8	10.76	7.79	7.13	0.34	-	4.49	0.39
DN 100 ISO K	mm	12	199.3	222.5	222.2	294.5	130	-	-	-	116.1	10.2
	inch	0.47	7.85	8.76	8.75	11.48	5.12	-	-	-	4.57	0.4
DN 100 CF-F	mm	16	209.3	232.5	232.2	304.9	148.5	130.2	8.6	16	109.5	9.8
	inch	0.63	8.24	9.15	9.14	11.89	5.85	5.13	0.34	-	4.31	0.39

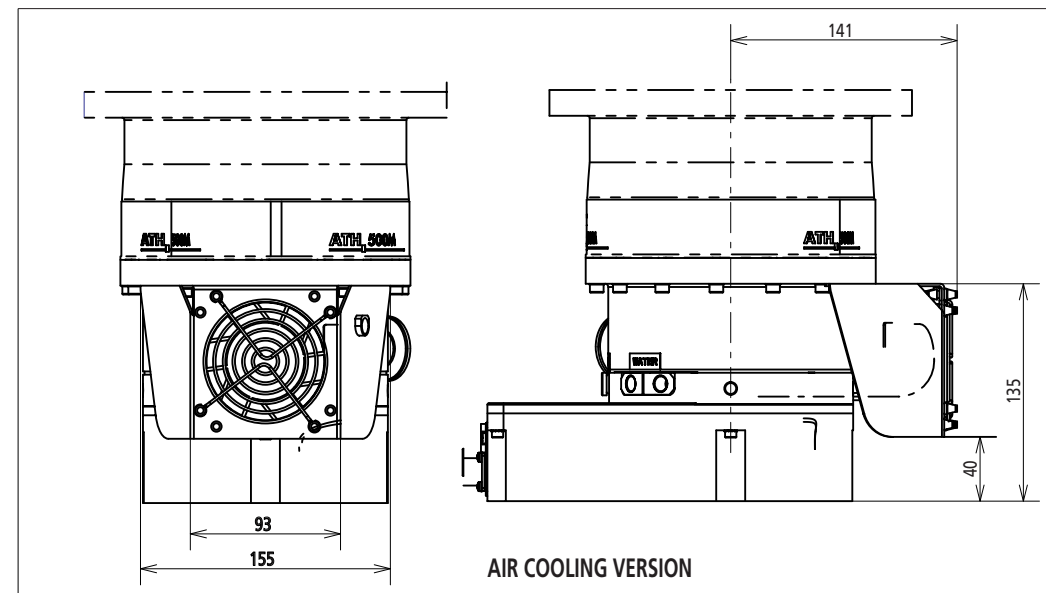

# A 400

## Technical characteristics of the pumps

### Dimensions mm (inch) ATH 500 MT

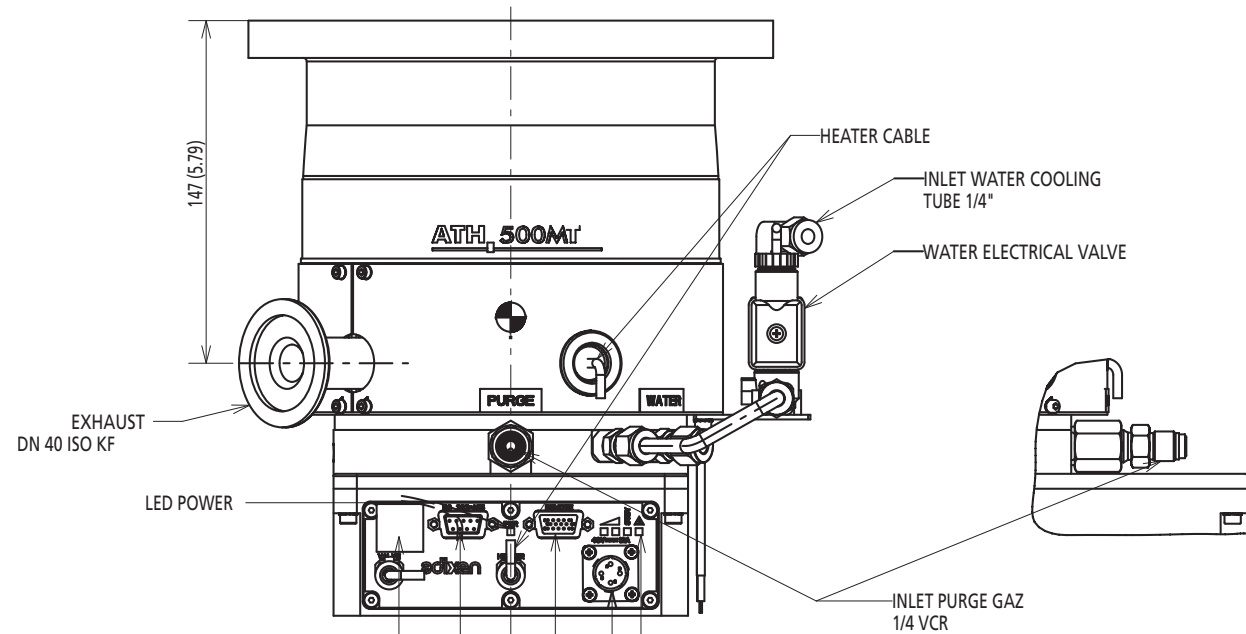
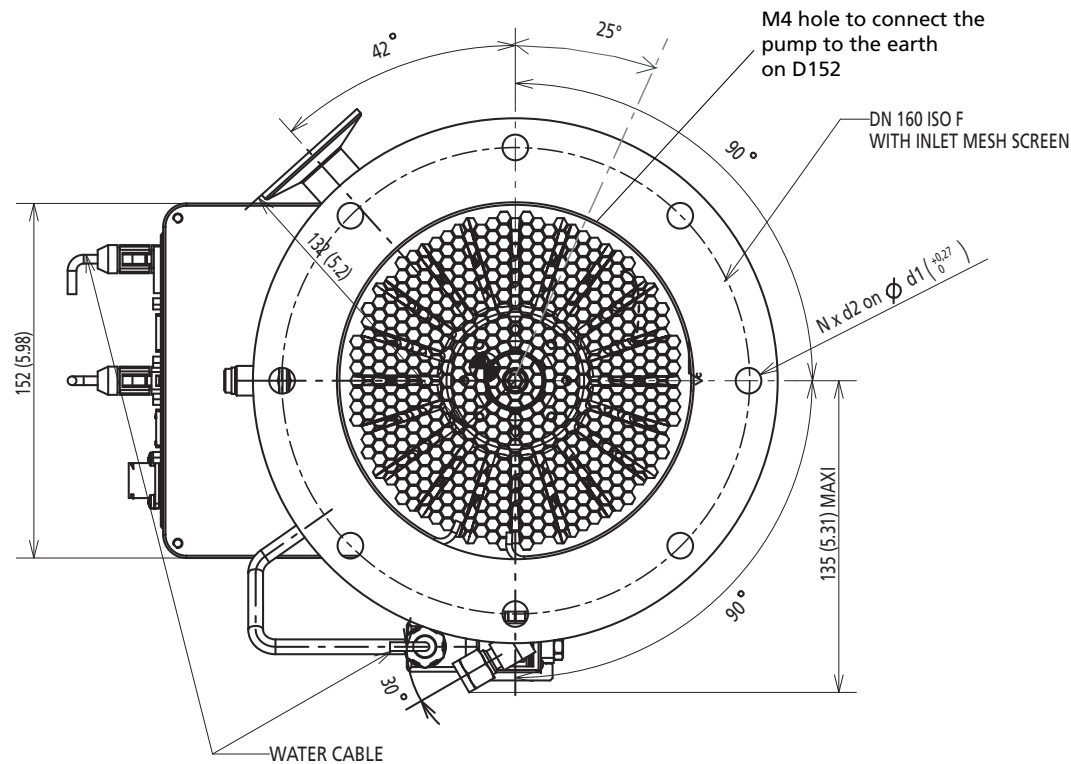
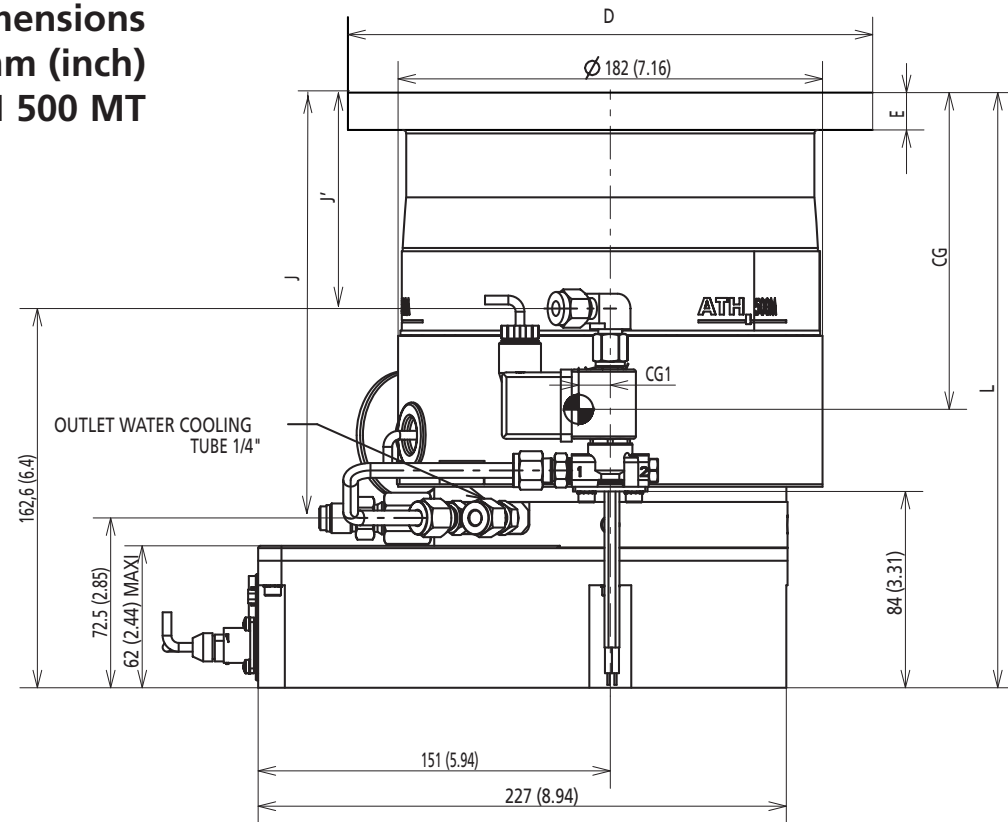

### ELECTRONIC FRONT PANEL

center of gravity

Dimensions in mm (inches)

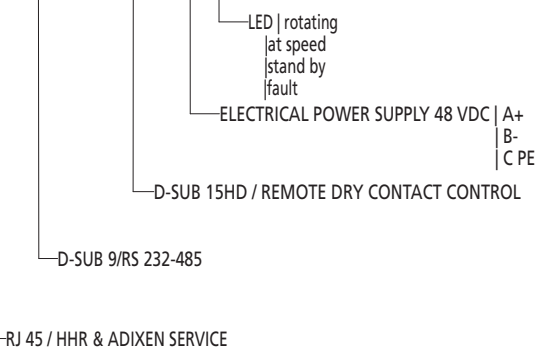

Inlet flange		E	H	J	K	L	D	d1	d2	N	CG	CG1
DN 160 ISO F	mm	16	159.3	182.5	182.2	254.9	225	200	11	8	112.6	9.7
	inch	0.63	6.27	7.18	7.17	9.94	8.86	7.87	0.43	-	4.43	0.38
DN 160 ISO K	mm	12	159.3	182.5	182.2	254.9	180	-	-	-	128.6	11.3
	inch	0.47	6.27	7.18	7.17	9.94	7.09	-	-	-	5.06	0.44
DN 160 CF-F	mm	20	180.3	203.5	203.2	275.9	198	181.1	8.6	20	114.1	10.1
	inch	0.79	7.1	8.01	8	10.76	7.79	7.13	0.34	-	4.49	0.39
DN 100 ISO K	mm	12	199.3	222.5	222.2	294.5	130	-	-	-	116.1	10.2
	inch	0.47	7.85	8.76	8.75	11.48	5.12	-	-	-	4.57	0.4
DN 100 CF-F	mm	16	209.3	232.5	232.2	304.9	148.5	130.2	8.6	16	109.5	9.8
	inch	0.63	8.24	9.15	9.14	11.89	5.85	5.13	0.34	-	4.31	0.39

## The accessories of the pump

### Power supply (external)



Description	P/N
48V DC (180-264 V, 47-63 Hz)	114866

delivered without power cable

### Power line cable

Cable to connect the power supply to the pump

Description	P/N
3.5 m - 48 VDC	A331328-035
5 m	A331328-050

### HHR (Hand Held Remote)

It ensures Man-Machine interface for local use.



Description	P/N
(with cable)	114461

### Mounting bolts kit

Screws and washers used to secure the pump on the installation

Flange type	P/N
DN160 ISO F	110676S
DN 100/160 CFF	118690

### Purge plug

A plug can be connected instead of the filter.

Description	P/N
Plug with o-ring	115298S

### Purge valve kit

The purge valve must be driven by the customer (not used on the MT version)

Description	P/N
Purge valve kit 24 VDC	115303S

## The accessories of the pump

### Isolation valve at inlet or exhaust pump

The isolation valve is used to maintain the vacuum in the chamber while the pump is reset to atmospheric pressure.

See the manufacturer's products catalog.

### Copper seals for pumps with CF-F flanges

Flange type	P/N
100 CF-F	303291*
160 CF-F	303292**

\* kit of 10 parts

\*\* kit of 5 parts

### Inlet screen

The screen protects the pump inlet against solid particles.

Description	P/N
DN 100 ISO F (mesh and ring)	118001
DN 160 ISO F (mesh and ring)	118002

### Air cooling kit

Description	P/N
Air cooling kit	118543S



# Start-up

## ATH 500 M-MT User's Manual Detailed contents

---

<b>B 100</b>	<i>Safety instructions for installation</i>
<b>B 201</b>	<i>Unpacking and storage</i>
<b>B 300</b>	<i>Pump connections to an installation</i>
	<ul style="list-style-type: none"><li>- Equipment installation conditions</li><li>- Maglev pump connection instructions</li><li>- Installations specifications</li><li>- Inlet flange installation conditions</li></ul>
<b>B 310</b>	<i>Inlet and exhaust connections</i>
<b>B 330</b>	<i>Nitrogen purge and air inlet valve device connections</i>
<b>B 333</b>	<i>Assembly of the purge kit</i>
<b>B 340</b>	<i>Water cooling connection</i>
<b>B 350</b>	<i>Air cooling connection</i>
<b>B 400</b>	<i>Safety instructions and electrical connections</i>
<b>B 430</b>	<i>«Remote control» connection wiring</i>
<b>B 450</b>	<i>RS 232 or RS 485 link wiring</i>

---

## Safety instructions for pump and controller installation

<b>CAUTION</b>	Indicates a potentially hazardous situation which, if not avoided, could result in property damage.
<b>⚠ CAUTION</b>	Indicates a potentially hazardous situation which, if not avoided, could result in moderate or minor injury. It may also be used to alert against unsafe practices.
<b>⚠ WARNING</b>	Indicates a potentially hazardous situation which, if not avoided, could result in death or severe injury.
<b>⚠ DANGER</b>	Indicates an imminently hazardous situation that, if not avoided, will result in death or severe injury (extreme situations).

### Overview

Before switching on the product, study the Operating instructions and make sure you follow the safety instructions. You can recognise these by the 'Caution', 'Warning' and 'Danger' symbols. Good practice tips and manufacturer's recommendations are in a blue box.

The performance and operational safety of this product are guaranteed provided it is used normally in the operating conditions defined in this manual.

It is the customer's task to:

- train operators to use the product if they do not speak the language the manual is written in,
- ensure operators know the safe practices to apply when using the product.

We took care to provide you with a clean product. To keep it in this condition, unpack it only in contamination free area and at final place of use.

### For emergencies

For emergencies and breakdowns, contact the manager of your local service center (see addresses at back of operating instructions or on our website).

Make sure the equipment shows no sign of transport damage. If it has been damaged, take the necessary steps to record this with the carrier and inform the manufacturer. In all cases, we recommend keeping the packaging (reusable materials) for further transport of the equipment or for prolonged storage.



## Safety instructions for pump and controller installation

The turbomolecular pumps can't evacuate at atmospheric pressure, they are connected to a roughing pump. For a transient period, they can start to run at atmospheric pressure.

Our products are designed to comply with current EEC regulations. Users making their own modifications to the product are liable to break its compliance with these regulations, degrade its EMC (electromagnetic compatibility) rating, and make it unsafe to use. The manufacturer declines all liability for the consequences of such operations.

### WARNING

Do not expose any part of the human body to vacuum. The product is supplied with the inlet and exhaust sealed. Remove these blanking plates when you are ready to connect the product on your vacuum system. As well as, don't operate the product unless the inlet and exhaust are connected to a vacuum and exhaust pumping line.

### Handling

### WARNING

#### ■ Heavy product:

It must be removed from its crate only by staff trained in heavy materials handling :

- either manually (weight around 18 kg)
- either by screwing hoisting rings in the threaded holes located on the pump housing (hoisting ring supplied by customer)
- then, use slings from a length over 230 mm.
- tighten the pump to the handling device.

■ Risk of tilting: although the product meets EEC safety regulations , it is advisable to guard against the risk of tilting during handling, installation, and use. ( chapter A for the location of the center of gravity).

### Installation

### DANGER

#### ■ Pump connection to the installation:

It is strongly recommended to secure the maglev turbopump installation to prevent any safety hazard to the user in standard operating conditions : ( B 300).

#### ■ Risk of cut injury:

The access to the rotor of a turbomolecular pump with an unconnected inlet port is dangerous. In the meantime, if the pump is not switched on, it may be driven by another pump in operation.

Always connect the pump inlet port before starting the pump.

### CAUTION

Make sure all parts and chambers connected to the inlet, exhaust and purge of the maglev pump can withstand a negative pressure of 1 bar below atmospheric pressure and that they are impervious to damage from vacuum (seals, etc.).

## Safety instructions for pump and controller installation

### Installation (cont'd)

#### WARNING

The user and /or OEM are ultimately responsible for operating the equipment in a safe manner. The manufacturer has no control over the types of gases exposed to this pump. This is the user and/or the OEM's responsibility to follow the necessary safety requirements.

Frequently process gases are toxic, flammable, corrosive, explosive and/or otherwise reactive.

Toxic gases can cause serious injury or death. Operators and users must take the appropriate safety recommendations to prevent injury. Consult the responsible department for instructions and safety information.

Hazardous gases through the pump can cause serious injury or death. It's mandatory by regulations to connect the turbomolecular pump's exhaust to a rough pumping line compatible with the process gases. Check that pump is correctly connected to the equipment (  B310).

#### DANGER

■ If any corrosive, reactive, flammable, pyrophoric, oxidizing process gases can be sent to the pump, then an exhaust extraction system monitor should be used to ensure that gas flow to the pump is stopped when exhaust gas extraction system is lost.

If flammable materials are sent to the pump, the customer will need to provide a hardware based LEL detection in the exhaust extraction system (detection capability at 25% of the LEL) that will stop chemical supply to the pump when gas is detected over 25% of LEL for that flammable material.

■ For non clean process.

If loss of purge flow creates a significant risk, then the purge flow must be monitored externally and a response to loss of purge flow must be provided by the process equipment and interlocked.

If pyrophoric materials above the LEL (lower explosive limit) are sent to the pump then nitrogen should be supplied at a rate to ensure that concentration is diluted to be below the LEL, in addition an interlock should be provided to ensure that gas flow to the pump is stopped when nitrogen is lost.

#### CAUTION

■ The product's EMC rating is obtained on the understanding that it is installed in compliance with EMC rules.

Specially: in environments that are prone to emit interference, use shielded cables and connections on interfaces.

■ Ensure that the product is connected to an electrical installation:

- in compliance with the local and national safety requirements,
- equipped with electrical protection (fuses, circuit breaker, ...) which has a suitable earth (ground) point, properly connected.

■ This pump is not equipped with a lock out/tag out (LO/TO) device because it is designed for use on process tools.

In order to properly secure the pump for installation or/and maintenance, the entire tool needs to be properly locked-out/tagged out in accordance with OSHA requirement 29 CFR.1910.147.

■ If access to the IEC connector is restricted an additional isolation device should be provided, which will be easily accessible by an operator.

## Safety instructions for pump and controller installation

### Installation (cont'd)

** WARNING****■ Electric shock hazard.**

The voltages and currents in use can induce electric shock.

Isolate and lock out power line to the product before maintaining it /or removing the cover.

Only skilled, authorized people may carry out maintenance work.

If a main isolator is installed by the customer, it must be in compliance with local regulations, with a minimum interrupting short circuit current of 10kA.

**■ Electric shock hazard.**

Some components have capacitors charged to over 60VDC, or motor operating as generator. When power is switched off, they keep their charge for a time. Take precautions concerning the access to the connector pins. Wait at least 5 minutes after the pump comes to complete stop before starting any work.

**■ Other located hazardous energies.**

Water cooling circuit and nitrogen purge are pressurized hazardous energies.

Release pressure before servicing:

1 - for the N2 purge, disconnect the gas line ;

2 - for the water cooling circuit, disconnect the input connector and leave the output connected. Don't forget to put a vessel ( $\geq 1$  l) under the water output.

**■ Operation in local mode**

There is no device to warn that the pump operates in local mode. When the pump is not integrated in the equipment/host tool, the user must provide a device to warn that the pump operates in local mode.

**■ The products are factory tested to ensure they will not leak in normal operating conditions. It is the user's responsibility to ensure this level of leak tightness is maintained.**

**■ Specific operating conditions may exist that require extra caution from users due to the high temperatures generated (outer surfaces  $> 70^{\circ}$  C):**  
Wear protective gloves and leave the pump to cool before working on the product.

## Safety instructions for pump and controller installation

### Installation (cont'd)

#### DANGER

##### Safety interlock.

The pump motor is protected against overload through the drive «start/stop» and enable control circuitry of the variable speed controller. The drive start/stop includes solid state components. If hazards due to accidental contact with moving machinery or unintentional flow of liquid, gas or solids exist, an additional hardwired stop circuit is required to remove input power.

It is never required to override this interlock during installation, use or maintenance.

Once activated power will be switched off and the pump will be put in a safe condition. When a fault occurs, the cause must be corrected before the fault can be cleared. It is required to switch power off and on to clear the fault.

#### CAUTION

■ If the product is used in applications where solid particles or condensable gases are present, we advise on avoiding any deposition into the pumping line. Contact our customer service.

■ The manufacturer guarantees the right operation of the pump if it is used in a uniform magnetic field up to 0.5 mT.

From 0.5 to 5 mT the limit of the right operation depends on the cooling and the gas loads.

Exceeding 5 mT can cause excessive rotor heating due to the eddy generated currents. It is therefore necessary to provide suitable shielding in such cases. The pump standalone is resistant to radiation at levels up to  $10^3$  Gy.

■ The units containing control circuits are designed to guarantee normal safety conditions taking their normal operating environment into account (use in rack).

In specific cases of use on tables, make sure that no objects enter the ventilation openings or block the openings when handling the units.

## Safety instructions for pump and controller installation

### Labels stuck on the product

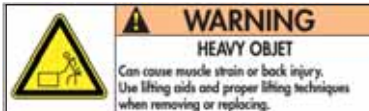

This label indicates that handling the pump can cause muscle strain or back injury. For all product handling, use the appropriate handling devices.



This label indicates that some of the internal parts are energized and could cause electrical shocks in case of contact. It advises to disconnect the pump before any intervention or to properly lock-out and tag-out the equipment breaker before any intervention on the pump.



This label warns the user against possible risk of injury due to any hand contact with hot surfaces. It states that protective gloves should be used before performing any intervention.

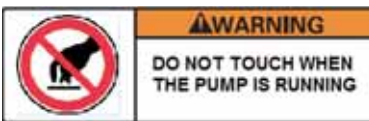

Avoid causing a shock on a pump when the rotor is moving, it can block the right operation.

### Other labels

Customer is in charge to stick these labels on the ATHM on the most appropriate location to warn the operator regarding the probable hazards.



This label informs the user that moving parts present inside the pump could cause personal injury, like crushing or cutting. The user must keep all body parts away from moving parts.



The «hot surface» sticker must be stucked conspicuously on the pump housing.



The user must label visibly the product to warn against pumped process gas that could be dangerous and toxic and could cause severe injuries or death. It precises that any preventive maintenance operation can only be performed by trained personnel.

## Unpacking and storage of the pump

### Unpacking

Make sure the equipment shows no sign of transport damage. If it has been damaged, take the necessary steps to record this with the carrier and inform the manufacturer. In all cases, we recommend keeping the packaging (reusable materials) for further transport of the equipment or for prolonged storage.

The packaging depends on the configuration of the pump. It can also contain other cardboard boxes for the accessories like: inlet screen, air inlet valve, purge device, high temperature sticker, electric cable...

#### CAUTION



#### Pollution risk:

Unclean and contaminated components can increase the pump down time. Use only dry and clean pipe lines, and wear gloves to make the pump connections.

### Pump handling

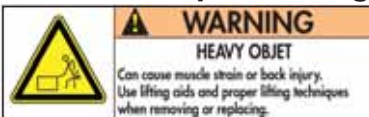

This label indicates that handling the pump can cause muscle strain or back injury.

For all product handling, use the appropriate handling devices.

#### WARNING

#### ■ Heavy product:

It must be removed from its crate only by staff trained in heavy materials handling :

- either manually (weight around 18 kg)
- either by screwing hoisting rings in the threaded holes located on the pump housing (hoisting ring supplied by customer)
- then, use slings from a length over 230 mm.
- tighten the pump to the handling device.

Pump installation with inlet housing facing up: connect the pump to the customer's handling device using the threaded holes located at the pump housing (📖 chapter A400).

■ Risk of tilting: although the product meets EEC safety regulations , it is advisable to guard against the risk of tilting during handling, installation, and use (📖 chapter A for the location of the center of gravity).

### Pump storage

#### CAUTION

If you are storing the new pump, keep it wrapped in to its protective film. Our product can be stored in the following conditions:

- in a clean, dry and contamination free environment,
- at an ambient temperature between - 5°C and + 50°C,
- for a period of 1 year maximum.

If you need to store a pump which has run on clean process, don't forget to blow out the water line and to purge the pump with N2. Seal the inlet, exhaust and purge ports with blanking plates. Don't store the pump more than 6 months in a clean and dry environment.

Never store a pump which has been used on corrosive process. Return it to a repair service center (📖 E100)

---

## Unpacking and storage of the pump

**⚠ WARNING**

The product is supplied with the inlet and exhaust blanked off. This prevents foreign bodies entering the pump during transport and storage. Do not remove these blanking plates until you are ready to install the product on the vacuum line.

Inlet	ASA, ISO or CF-F blanking flange (depends on the model).
Exhaust	Blanked with a DN40 ISO-KF or DN25 ISO-KF blanking plate (depending on the models)
Connection purge device	Closed with a purge plug.
Electrical connectors	The connectors are protected by plastic caps. Left them in place for storage of the product.



## Pump connections to an installation

### Equipment installation conditions

#### **⚠ WARNING**

The equipment frame on which the pump is installed must be sufficiently rigid to absorb the kinetic energy of the rotor in case of pump rotor crash. For this, take into account :

- the maximum loads to calculate the equipment attachment devices,
- the flange dimensions,
- the quality and the number of bolts.

Do not use bellows on the pump inlet flange and the chamber Reducing adapter must be correctly dimensioned.

When the pump is connected according to the manufacturer recommendations (  B300 ), in case of overpressure resulting from an incident, the pump enclosure can withstand a maximum static pressure of 11 bar for 1 minute.

#### **⚠ WARNING**

Pump installation :

- connect the pump to the customer's handling device using the threaded holes located at the pump housing (  A400).

The pump can operate in any position

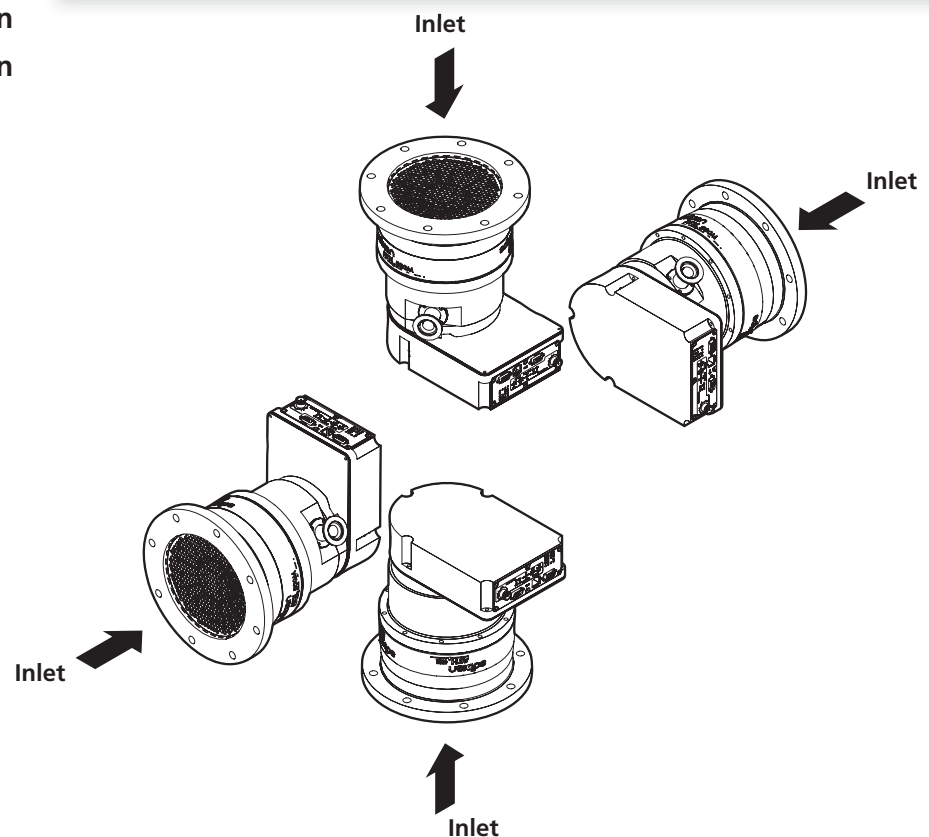



## Pump connections to an installation

**Magnetically levitated pump connection instructions.**  
**Why securing Magnetically levitated pump installation?**

Maglev hybrid Turbopumps are designed so as to prevent any safety hazard to the user in standard operating conditions. However, some operating conditions may generate hazards for the user and the environment : **the kinetic energy stored in a maglev turbopump is high. In case of a mechanical failure an improperly installed pump could be ejected from the equipment if the kinetic energy was transferred to the pump body.**

**⚠ WARNING**

It is absolutely necessary to install the pump according to the following installation specifications to secure the user and the equipment.  
 The adixen constructor declines any responsibility if the pump installation is not designed in accordance with the installation specifications described in this section.

### Installations specifications

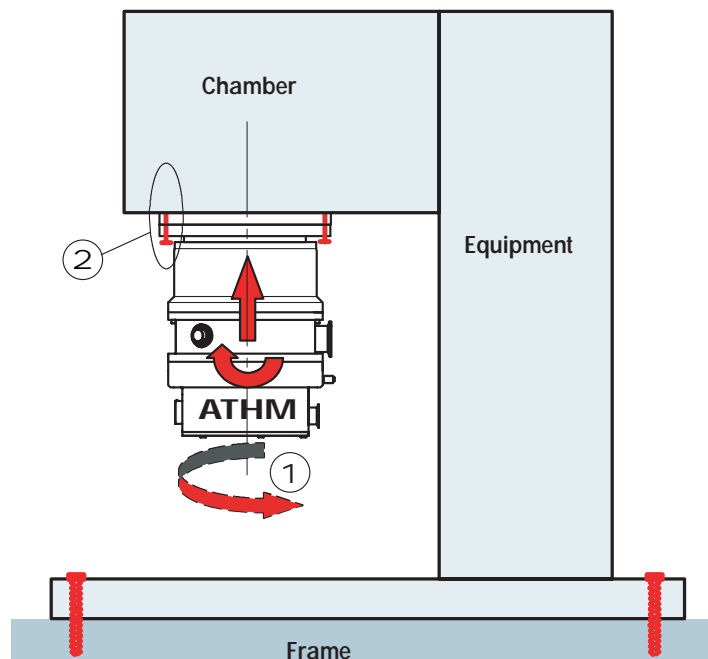

**Maglev pump connection instructions**

Respect the items 1 and 2.

## Pump connections to an installation

### Worst Case Turbo Pump Crash Scenario Definitions

The kinetic energy of the rotor has to be absorbed by the installation if **the pump seizes suddenly**.

The maximum resulting loads have been estimated: simulation of a worst case Turbo pump crash with **a rotor split into 2 parts at nominal speed**. The impact of the rotor parts creates the following **transient loads**.

#### Axial loads (a)

The rotor parts can be ejected out of the pump inlet flange and can impact on the plate of the valve or any other part of the system. If this is placed close to the turbo pump and if it has high stiffness the impact can create a high axial load on the system. Such axial force has not been observed on a standard pendulum valve.

#### Bending moment (b)

The impact of the rotor parts on the housing will create a radial force on the housing. This radial force will create a bending moment on the system as a function of the distance to the pump. The deceleration of the rotor parts creates a torque value on the pump housing, which is transmitted to the system.

#### Torque (c)

The maximum values of the axial force and the bending moment occur at approximately the same time. A delay of up to several ms has been observed for the maximum torque value.

### Loads transmitted to the system (item 1)

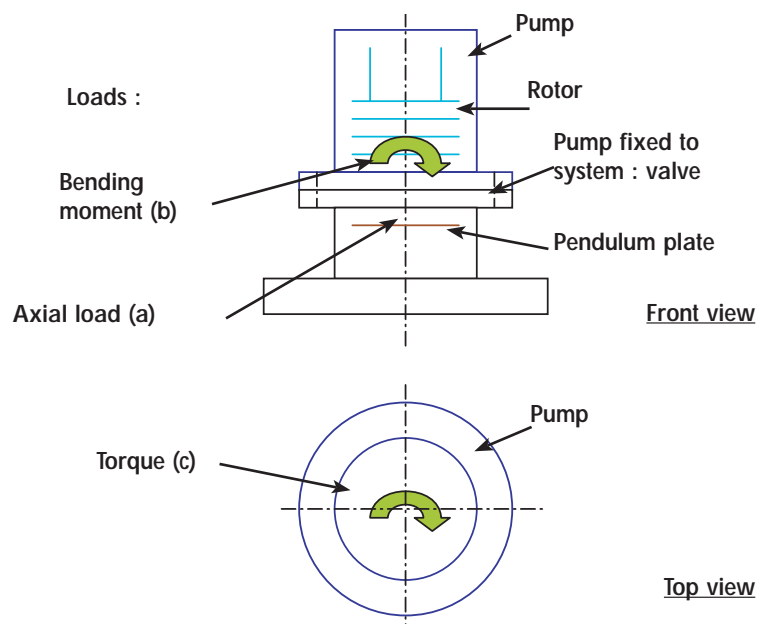

## Pump connections to an installation

### Loads transmitted to the system (cont.)

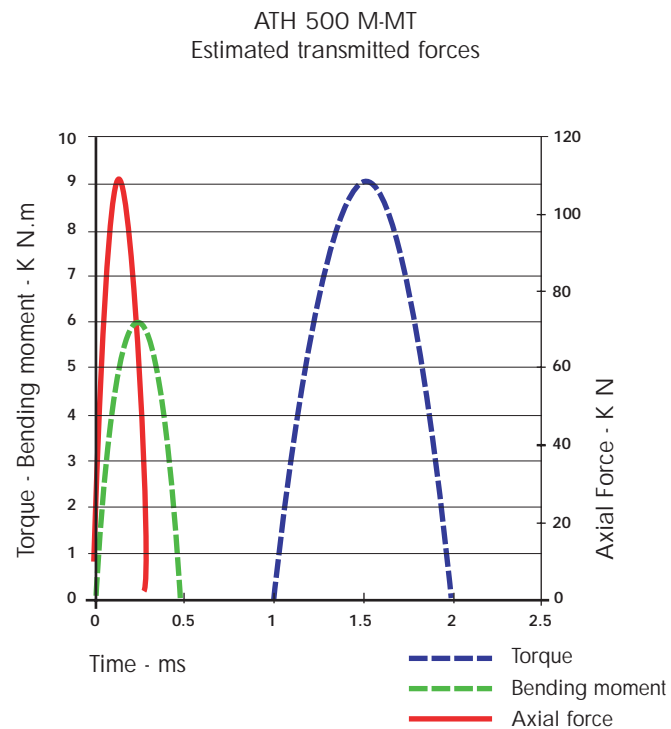

Pump model	Unit	ATH 500 M-MT
Nominal speed	rpm	50 000
Energy	kNm	24
Torque	Max. KNm	9
	Duration ms	1
	Delay ms	1
Bending moment	Max. KNm	6
	Duration ms	0.5
	Delay ms	0
Axial force *	Max. KN	0 to 110
	Duration ms	0.3
	Delay ms	0

\* Max. axial force occurs if the pump inlet is obstructed with high stiffness parts. There is no load if the system has low stiffness (i.e. valve).

## Pump connections to an installation

### Inlet flange installation conditions (item 2)

The resulting maximum loads from a crash have to be taken into account by the pump assembly bolts.

**Design and secure the pump frame so that it can withstand the loads.**

Mounting holes at inlet flanges	ATH 500 M-MT			
	DN160 ISO-F ou ISO-K	DN100 ISO-K	DN160 CFF	DN100 CFF
Type of bolts *	M 10	M 8	M 8	M 8
Number of bolts *	8	8	20	16
Length of bolts (mm)	≥ 35	–	≥ 40	≥ 35
Bolt metric grade *	12-9	12-9	12-9	12-9
Installation torque per bolt (N.m)*	30	20	20	20
Total clamping force (N)	108000	88500	222000	177000

\* Type, Number, Grade and Torque are mandatory

### DANGER

For safety reasons, it is important to tighten the bolts with a torque wrench according to the specified values :

- lower torque: risk of loosened bolts
- higher torque: risk of damaging the bolts.

### DANGER

We strongly recommend the use of ISO-F or CF-F flanges. ISO-K type flanges are not recommended to fasten turbomolecular because:

The ISO-K flanges do not prevent accidental rotation of the pump on the equipment flange in case of pump rotor crash. This rotation could damage the foreline and the purge gas line which would generate hazards for the user.

- For ISO-K flanges, we recommend to use a rotatable flange. In case of use of claw clamps, mount the same number of claw clamps (in stainless steel), as the number of screws recommended for the ISO-F flange.

### Equipment installation conditions

If the equipment cannot withstand the maximum loads in case of rotor crash, please contact the manufacturer for further consultations.

## Inlet and exhaust connections

### Vacuum connections

#### **WARNING**

Do not expose any part of the human body to vacuum.  
The product is supplied with the inlet and exhaust sealed. Remove these blanking plates when you are ready to connect the product on your vacuum system.  
As well as, don't operate the product unless the inlet and exhaust are connected to a vacuum and exhaust pumping line.

#### **CAUTION**

Risk of injury by cutting.  
Contact with the pump rotor cell may cause cuts. Alternatively, protective gloves may be worn when servicing the product.

#### **CAUTION**

Make sure all parts and chambers connected to the inlet, exhaust and purge of the maglev pump can withstand a negative pressure of 1 bar below atmospheric pressure and that they are impervious to damage from vacuum (seals, etc.).

#### **CAUTION**

For safety reasons, use accessories on the inlet and exhaust lines whose materials and sealing properties are compatible with the gases being used.

#### Materials in direct contact with process gases

COMPONENTS IN THE PUMP	MATERIALS
From inlet to outlet	Stainless steel, aluminium alloy
O-ring	Fluorinated elastomers, FPM

#### **WARNING**

Pump installation :  
- connect the pump to the customer's handling device using the threaded holes located on the housing of the pump (  A400).

#### **CAUTION**



Pollution risk  
Unclean and contaminated component use can increase the pumping down time. Use only dry and clean pipe lines, and wear gloves to make the pump connections.

After connecting the product to the pumping line, check for leaks along the entire line to ensure proper connections (pump, pipes, valves, etc.).

## Inlet and exhaust connections

**At inlet:** Check that an inlet screen accessory is installed on the pump ; if not, install it. (pumps are delivered with inlet screen filter).

### Mounting of the inlet screen

Position the screen (2) into the inlet housing groove (1), bend side opposite to the rotor. Position the ring (3) and press it manually into the groove bottom all over its circumference.

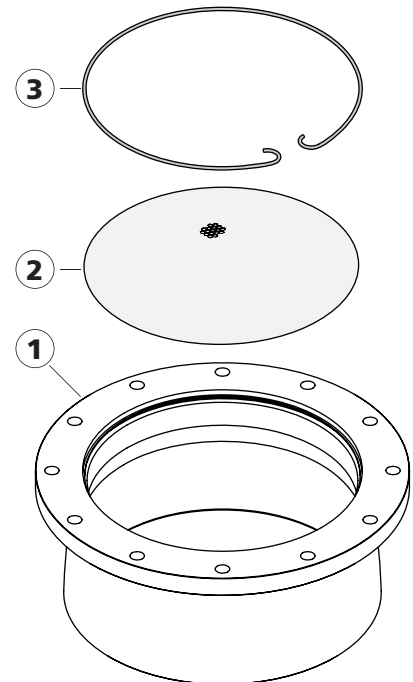
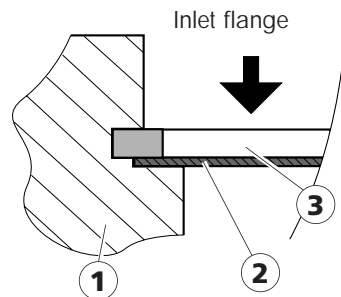

### CAUTION

It is recommended to install an isolation valve between the chamber to allow chamber venting without stopping the pump.

### At exhaust

The turbomolecular pumps can't evacuate at atmospheric pressure, they are connected to a roughing pump. For a transient period, they can start to run at atmospheric pressure.

### WARNING

When pumping on corrosive gases, or aggressive gases, the gas can cause injury or death. The exhaust of the turbopump must be connected to roughing pump line compatible with process gases.

### CAUTION

It is highly recommended to install an isolation valve (closed when power is off) between the turbo pump and the roughing circuit.

## Nitrogen purge connections

### Characteristics of filtered dry nitrogen supply

A filtered dry nitrogen supply with the following characteristics is required:

- H<sub>2</sub>O concentration : < 1 ppm
- O<sub>2</sub> concentration : < 1 ppm
- Dew point < 22°C
- Dust < 1 µm
- Oil vapor < 0.1 ppm
- Absolute pressure of 1 to 1.2 bar.

### WARNING

■ When the inert gas purge is stopped, the pumped gases can pass from rough vacuum side to high vacuum side and damage the maglev bearings. It is advised to maintain the purge flow as long as the rotor is running to protect pump internal parts.

■ The maximum pressure of the purge must not exceed 2 bar.

### Purge device for DN16 port (50 sccm)

The purge flow is continuous.

The integrated nitrogen flow reduction device controls the pressure and guarantees a flow rate of 50 SCCM at pressure 1.1 bars.

When used in dusty conditions, replace the filter regularly.

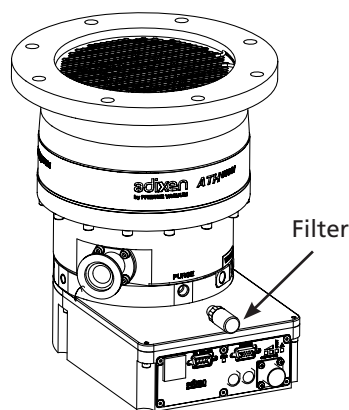
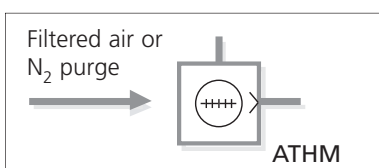

M Model

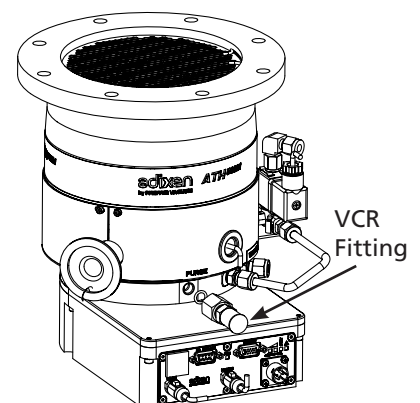

MT Model

### Connection

Connect directly the nitrogen pipe instead of the filter or the purge plug (connection 1 / 8 BSPP), or on the VCR connection (depending on pump model).

## Nitrogen purge connections

### Adjust the flow rate

Feed the nitrogen purge throughout pumping according to the flow rate and pressure value in the scale given.

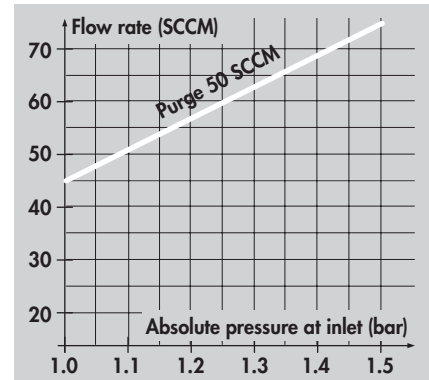

### Valve with built-in purge device (50 sccm)

This is an accessory directly installed on the ATH500M models (  B333).

The power of the valve is the responsibility of the customer (24 VDC).

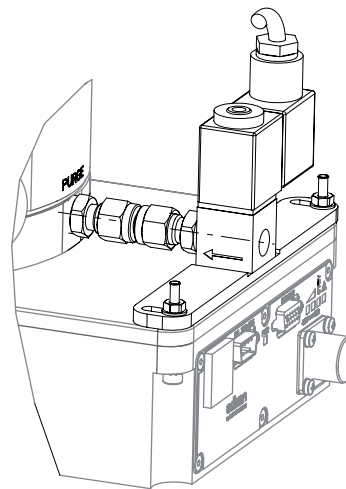
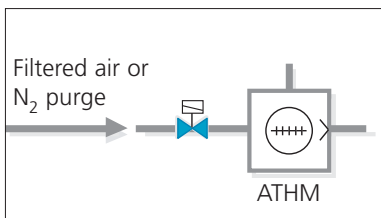

When using this valve, close it before making a leak detection test.



## Assembly of the purge kit

### Installation purge kit on ATH 500M

1/8 BSPF connection

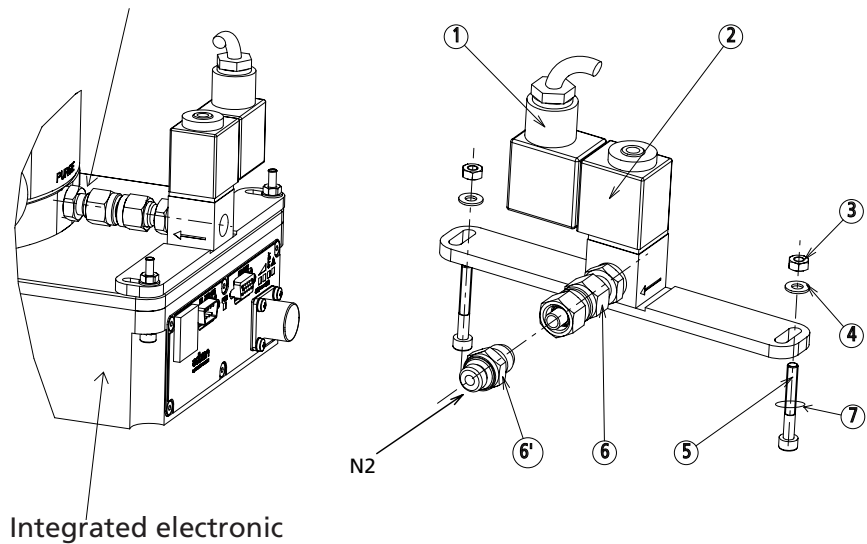

- 1 - Replace the screws M4-16 of electronic by the screws (5) and the washers (4) and (7).
- 2 - Remove the silencer or purge plug from the purge port.
- 3 - Screw the union (6') on the purge port.
- 4 - Install the assembly (2) on the top of the electronic box using screws (5) through the plate.
- 5 - Screw N2 gas line in the union (6').
- 6 - Tighten the nuts (3) with the washer (4).
- 7 - Test the vacuum tightness.

## Water cooling connection

### Characteristics of water cooling

In order to avoid corrosion and clogging of the cooling pipes, it is recommended to use cooling water with the following characteristics:

- Treated soft water or non-corrosive industrial water
- pH between 7.5 and 11
- Hardness: < 7 milli-equivalent/l  
= 350 mg/l of CaCO<sub>3</sub> calcium carbonate)  
= 35° F (French degree)
- Resistivity: 20 000 Ω.cm > R > 1 500 Ω.cm
- Solid pollution: < 100 mg/dm<sup>3</sup>
- Solid particle size (maxi): 0.2 mm
- Pressure range: < 7 bars
- Temperature \*:       15°C < T < 40°C for ATH 500M  
                                  15°C < T < 25°C for ATH 500MT
- Flow rate: 60 l/h

\* In case of water temperature is < 20 °C, there is a risk of condensation.

### CAUTION

■ The use of uncontrolled city water can lead to water circuit clogging due to limestone deposition, which may necessitate in the worst case a complete cleaning and overhaul of the water circuit.

■ The presence of micro-organisms like aquatic weed and micro-biological substances like bacteria can lead to cooling problem in the pump. Appropriate water treatment system need to be used to prevent growth of such micro-organisms.

### Water cooling connections M model

- Provide a water inlet pipe and a tap to adjust the flow rate.
- Apply, on the fittings (supplied by the customer), Teflon™ tape or glue type Loctite™ to seal the threads (connection 1/8 NPT).
- Screw manually the fittings on the pump.
- Connect the water inlet line to one of the water fittings and the other fitting to the water draining circuit.
- Check there is no leak.



## Water cooling connection

### Water cooling connections MT model

- Provide a water inlet pipe and a tap to adjust the flow rate.
- Connect the cooling circuit (tube 1/4") on the provided fittings in accordance with the flow direction (inlet water on the valve).



#### CAUTION

Water leak risk : maintain the water valve inlet fitting with a flat wrench during the water line connection (pipe equipped with connector), this to avoid fitting damage.

#### ⚠ WARNING

Do no install water fittings above electrical components : there is a risk of electrical discharge in case of a leak at the water fitting connection.

## Air cooling connection

### Fan installation on the pump

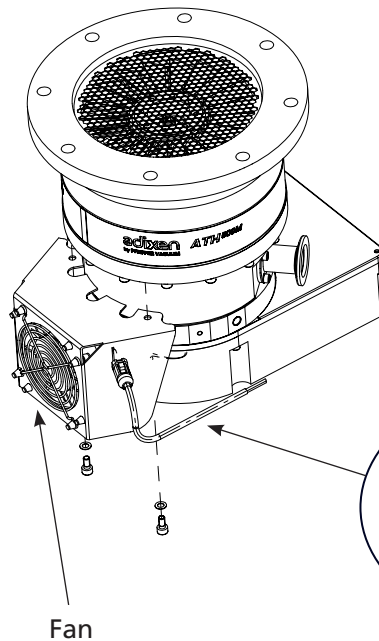

The air cooling kit can be separately ordered. The installation is the customer's responsibility.

When the pump is supplied with an air cooling unit, this one is equipped with a power cable.

### Fan electrical connection

The power supply fan requires a 48 VDC external power supply, supplied by the customer. The accessory suggested by the manufacturer (  **A510** ) is used to power the pump and the fan.

Perform wiring of the fan in accordance with the marks of the terminals and son (see diagram above) (  **B400** ) .

### Instructions to disconnect the fan

#### **WARNING**

The power supply should never be switched off as long as the rotor is moving.

#### **WARNING**

Switch off the power supply, before disconnecting the power supply from the ATH 500 M-MT.

## Safety instructions and electrical connections

### WARNING

- Risk of electric shock:  
Make sure that main switch is off during electrical connection.  
Disconnect any main power sources from the product prior to servicing.

### CAUTION

- The pump is Class 1 equipment and therefore must be earthed. The user must check the electrical installation to which the product is connected:
  - it must comply with current standards (IEC 364),
  - it must have a standards compliant earth wire, properly connected to earth.

### CAUTION

- An IEC 417#5019 symbol is located on the electric device. 
- Differential circuit breaker  
In case of insulation defect, for personnel protection you must install on the main power supply a type B differential circuit breaker GFI (or RCD) of 30mA. This equipment protection device is compatible with type T.T electrical network. For other network type T.N or I.T, apply the right protection device. Contact product manufacturer for advice. In all cases, comply with current local regulations.
- When units containing control circuits are equipped with dry contact outputs, it is the responsibility of the customer to use these outputs in compliance with extra low voltage installation and safety standards (SELV). It concerns Remote, Profibus and RS connectors except main power connector.
- Ensure that all electrical wiring is safely secured so that people cannot trip on them.

### WARNING

- Installation protection with circuit breaker  
The user must supply the product from facilities equipped with a main circuit breaker, curve D or C (IEC 60947-2) adapted to the power supply, in accordance with local regulations and with a minimum short circuit interrupting current of 10 kA.  
This protection device should be in close proximity to the pump (no further than 7m (25 ft) within line of sight of the pump.
- This pump is not equipped with an emergency stop EMO device because it is designed for use on process tools and integration with the process tool EMO. Check that the pump is correctly connected to the equipment emergency stop device.

## Safety instructions and electrical connections

### **WARNING**

- The integrated electronic is connected to the main power with a main cable separately delivered. Voltage and current are present on power cable and on the heater power line (if installed). Avoid to pinch or pull these cables and route them safely.
- Electric shock hazard.  
The voltages and currents in use can induce electric shock. Isolate and lock out power line to the product before maintaining it /or removing the cover.  
Only skilled, authorized people may carry out maintenance work. If a main isolator is installed by the customer, it must be in compliance with local regulations, with a minimum interrupting short circuit current of 10kA.
- If access to the IEC connector is restricted, an additional isolation device should be provided, which will be easily accessible by an operator.

For electrical connection, the user must:

- Provide a power switch or a circuit breaker in the electric installation ;
- Put it correctly, easily accessible by an operator ;
- Mark it visibly as an electrical interrupting device of the product.

### ATH 500 electrical connection

The pump runs with a 48 VDC electrical power supply:

- either ordered as an accessory (  A510),
- either supplied by the customer.

### 48VDC power supply characteristics

#### Internal protection fuse:

- Surface mount fuse
- Time-Lag T, L, 16A
- Breaking capacity 125A, 300ms

According to the peak power delivered by the supply power on 48V, add an additional protecting system on the pump power input of 48V DC.

If the pump is connected on a main 48VDC network (network within the meaning of the standard 61000-6), it is necessary to add a filter and a system of overvoltage peak limiting at the input of the power line of the pump: contact the Customer service.

Internally, the «-» pole of 48 VDC is connected to the earth.

## Safety instructions and electrical connections

### Pump electrical connection

1 - Identify the main index on the male connector of the pump.

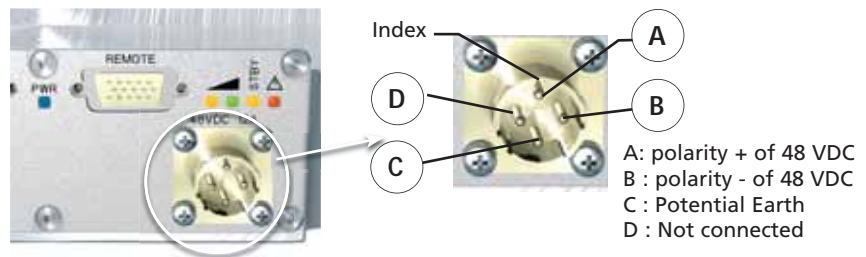

2 - Identify the main index on the female connector of the power supply's cable.

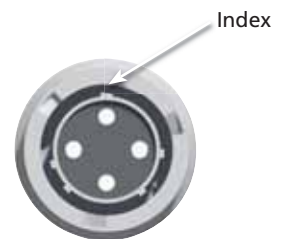

3 - Insert the female connector in accordance to the main index, then rotate the ring until locked

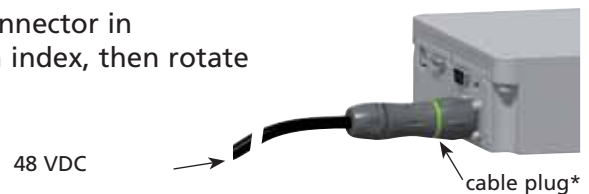

\*Plug : provided by the customer.  
Ref. UTS6JC1045 - Supplier : Souriau - France

4 - If the pump is equipped with a fan, supply it in 48VDC. The external power supply (accessory) allows to power the fan.

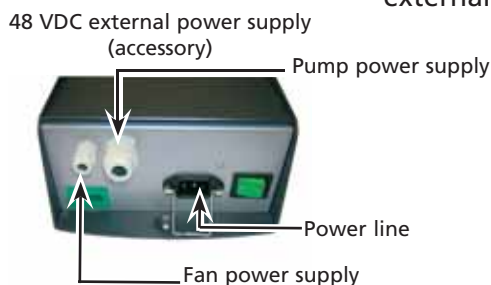

Blue cable eyes : pump power supply.

Red cable eyes : fan power supply.



### ATH 500MT uniquement

5 - Check that the heater band and the water valve are both supplied (connected on 'HEATER' and 'VALVE' electronic front panel).

### ATH 500M only

6 - If the pump is equipped with a purge valve, connect the valve to the 24 VDC power supply (customer supplied).

## Safety instructions and electrical connections

### Typical connection: In this installation, we use:

- A primary isolation valve V1 between the turbo pump and the roughing pump;
- a secondary isolation valve V2 between the turbo pump and the chamber to be pumped;
- a purge valve V3;
- a venting valve V4.

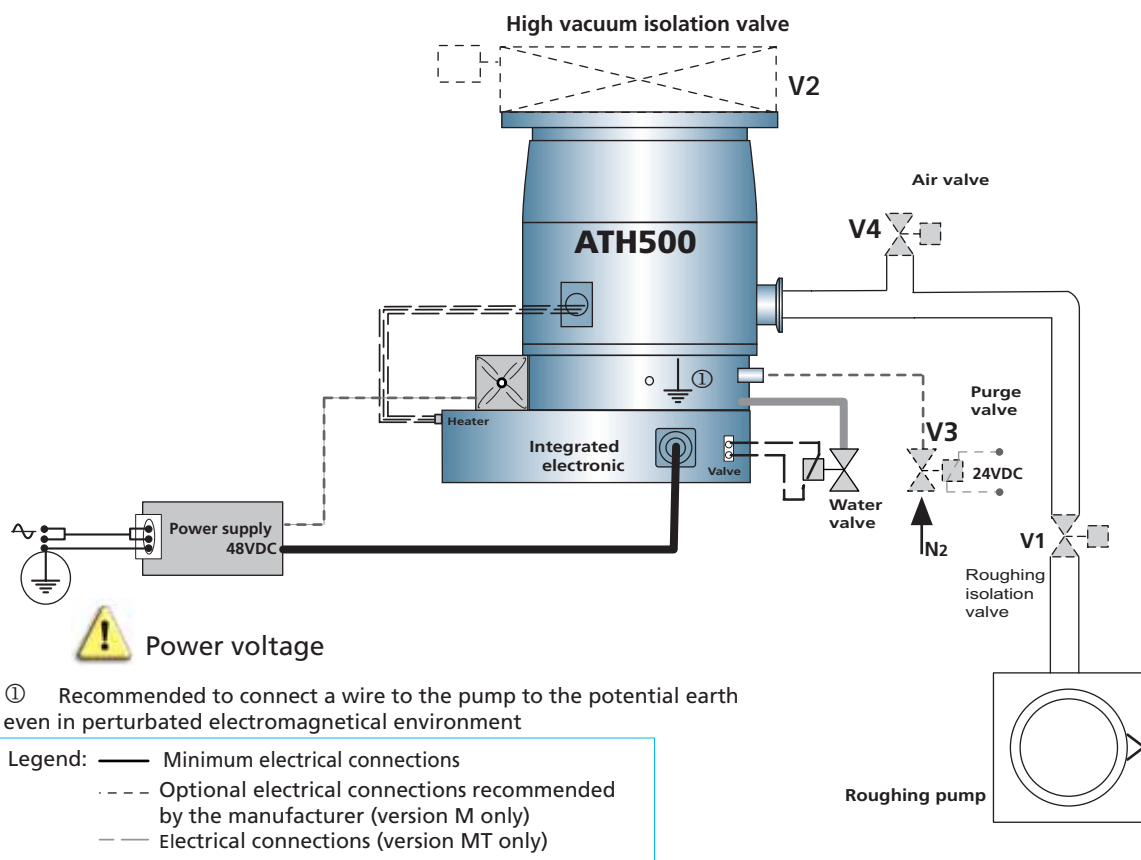

**Wiring diagram (typical)**

### **⚠ WARNING**

We recommend that you fit a separate earth (ground) conductor to earth pump. Use an un-insulated braid or a separate insulated green/yellow conductor with a minimum 9AWG (3mm<sup>2</sup>) conductor. Use a M4 x 8 screw and a shakeproof washer fitted to the earth hole from the pump to secure the earth conductor to the pump. The impedance between the pump-body and the earth connection point must be < 0.1 Ohm at 25 A.



## “Remote control” connector wiring

**CAUTION**

When units containing control circuits are equipped with dry contact outputs, it is the responsibility of the customer to use these outputs in compliance with extra low voltage installation and security standards. It concerns Remote, Profibus and RS connectors, excepted main power connector.

The inputs dry contacts Sub D 15 Pts Fem:

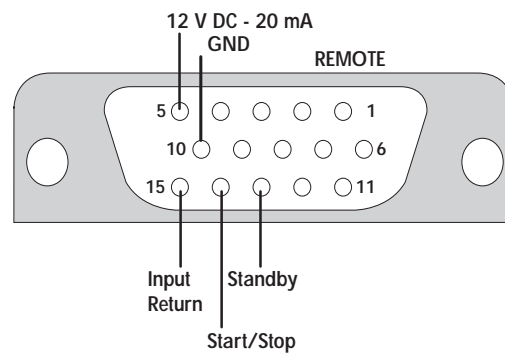

**The control by voltage**

12 V or 24 V DC

Remote function if “Remote hard” mode selected	Remote start/stop	14(+) 15(-)	<ul style="list-style-type: none"> <li>- Active signal starts the pump rotation.</li> <li>- Inactive signal stops the pump rotation.</li> </ul>
	Remote standby	13(+) 15(-)	<ul style="list-style-type: none"> <li>- When the “Standby” is validated, the rotational speed corresponds to the selected speed.</li> <li>- When the “Standby” is disabled, the rotational speed corresponds to the nominal speed.</li> </ul>

Provided power supply by the pump:

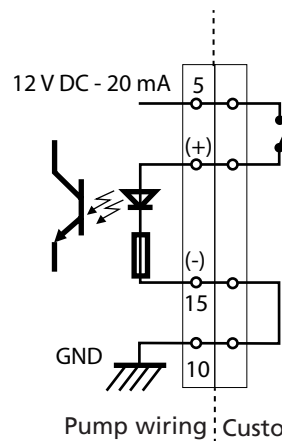

External power supply:

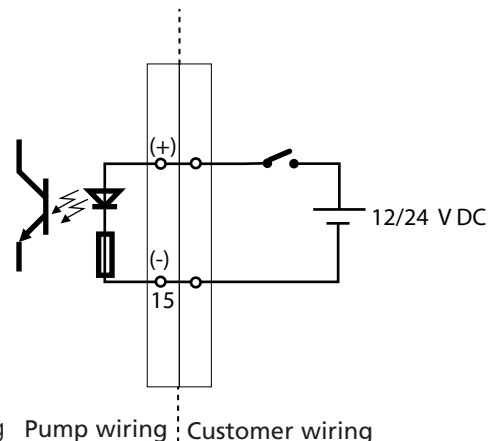

## “Remote control” connector wiring

### The output dry contacts

Sub D 15 Pts Fem.

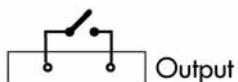

Dry contact  
30V DC - 2Amax  
Resistive load

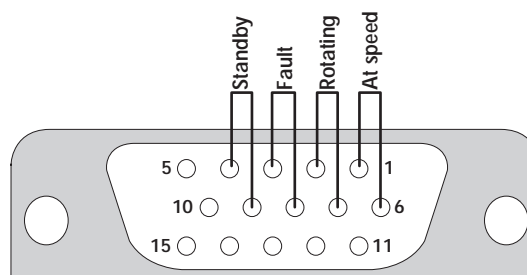

<b>OUTPUT**</b>	Independent of the “Remote hard” mode (safety)	<b>Standby</b>	<b>4 - 9</b>	- The contact is closed when the standby mode is activated
		<b>Rotating</b>	<b>2 - 7</b>	<ul style="list-style-type: none"> <li>- The ROTATING contact is closed when the speed is &gt;120 rpm</li> <li>- The ROTATING contact is open when the speed if &lt;100 rpm.</li> <li>- The ROTATING contact is closed when the motor is in acceleration phase. It remains closed until the selected speed is reached.</li> <li>- The ROTATING contact is open when a STOP or INHIBIT action is taken into account</li> </ul>
		<b>Fault</b>	<b>3 - 8</b>	<ul style="list-style-type: none"> <li>- The FAULT contact is closed following the appearance of any fault (temperature, frame, motor, etc...).</li> <li>- The contact is open if there are no faults.</li> </ul>
		<b>At speed</b>	<b>1 - 6</b>	<ul style="list-style-type: none"> <li>- The AT SPEED contact is closed when the selected speed is reached or when the pump is in overspeed mode (in the event of modification of reference speed),</li> <li>- The AT SPEED contact is opened when a STOP action is taken into account, or when the speed decreases under the threshold “relay speed” selected*.</li> </ul>

\* this threshold can be set between - 3 % and - 50 %.

\*\* To avoid any bad interpretation of the reading of the contacts, we advise to install an «one second filtering» on the reading of the contacts STANDBY, ROTATING, FAULT and AT SPEED.

## RS 232 or RS 485 link wiring

The initial configuration of the serial link is as follows:

- Type: **RS 232**
- Transmission speed: **9600 bauds**
- Data length: **8 bits**
- Parity: **NONE**
- Stop bit: **1**

### RS 232/485 connector wiring

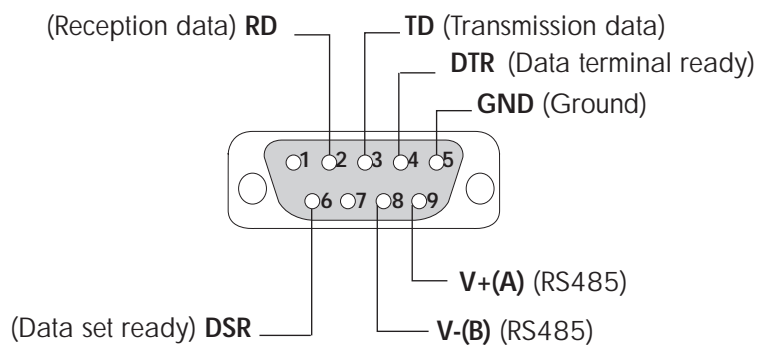

DB 9 contacts, male connector.

### Examples of possible connection RS 232 with a single controller



### Serial link RS 485

Parallel type connection: communication will be lost only on the disconnected pump.

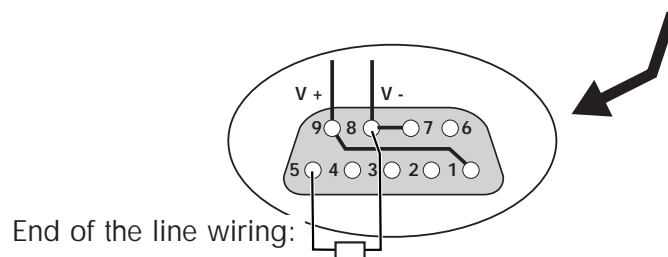
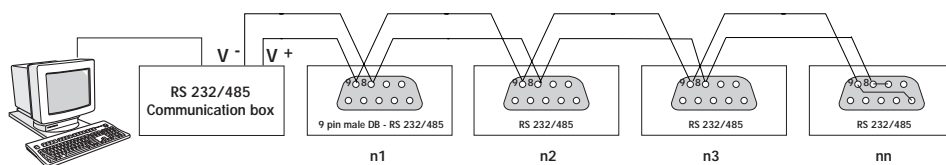

1.5 K  $\Omega$  - 1/4 W



## ATH 500 M - MT User's Manual Detailed contents

<b>C 100</b>	<i>Safety instructions for product use</i>
<b>C200</b>	<i>The front panel with operating status</i>
<b>C300</b>	<i>Configuring the ATH 500 M-MT for the application</i>
<b>C800</b>	<i>Detailed description of RS 232 and RS 485 commands</i>

## Safety instructions for product use

### WARNING

Before using pump and controller, make sure that the mechanical and electrical connections have been made according to the safety recommendations: refer to chapter B from pump operating instructions.

### CAUTION

It is highly recommended to use:

- an inlet screen at the pump inlet;
- an isolation valve between the chamber to be pumped and the pump;
- an isolation valve between the pump and the roughing pump.

### WARNING



- Do not operate the pump until it is securely fixed. If the pump seizes, the stored energy of the rotor may cause further damage and injury to people. (  B300).

- Risk of cut

The access to the rotor of a turbomolecular pump with an unconnected inlet port is dangerous. In the meantime, if the pump is not switched on, it may be driven by another pump in operation.

Always connect the pump inlet port before starting the pump.

- Specific operating conditions may exist that require extra caution from users due to the high temperatures generated (outer surfaces > 70° C): wear protective gloves and leave the pump to cool before working on the product. .

- Pump damage

Make sure that exhaust pipe line and pump internal parts are not clogged by process by-products (e.g. condensable products ...). If exhaust line is not clear, contact the customer service.

- As loss of cooling water creates a significant risk for the pump, regularly check the right operation of the cooling circuit.

### DANGER

- Risk of injury by cutting.

The inlet of the pump musn't be disconnected as long as the rotor is moving and without having disconnecting the power line cable.



### WARNING

Risk of electrical shock.

The turbopump and the controller must only be disconnected from each other when the turbopump is completely at rest and the controller disconnected from the power supply.

Never unplug the pump by disconnecting the main cable. Only the authorized and trained technicians can perform intervention on the product.

## Safety instructions for product use

 <b>DANGER</b>	
	<ul style="list-style-type: none"><li>- Use only specific cable.</li><li>- Lock connector before use.</li><li>- Do not unplug when the pump is on.</li></ul>

Located on the controller, this label indicates that the controller musn't be disconnected when the pump is running.

### **WARNING**

Standard precautions before any maintenance operations:  
Before performing a maintenance operation, stop the pump. When the pump is at rest, switch off the pump by setting the controller main switch to «0», wait 5 minutes before disconnecting the main cable.  
If this last one remains connected, some components will still be energized. Be sure that the controller status is visible from the operator otherwise disconnect the cable from the pump.

## The front panel

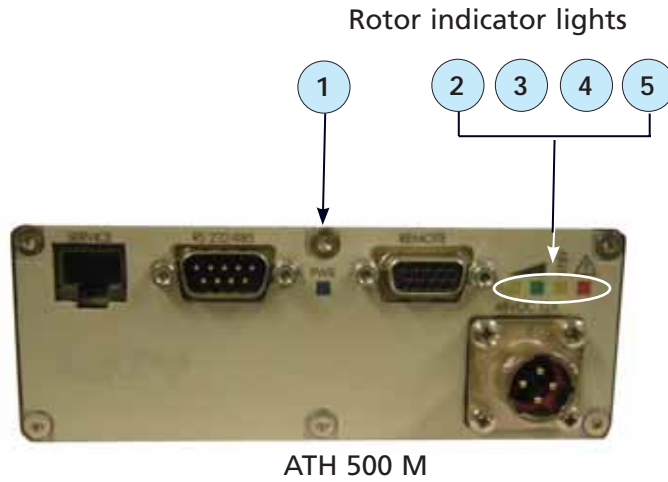

Light	Status	Information
1	Blue liting	The pump is powered.
2	Yellow liting	The pump accelerates.
	Yellow flashing	The pump decelerates.
3	Green liting	The pump has reached the selected speed
	Green flashing	The pump rotational speed is higher than the selected speed (decrease of the selected speed during operation)
4	Yellow liting	Standby mode selected
5	Red liting	The pump is faulty
	Red flashing	An alert appears

Wiring and communication protocol are available in a specific Operating Instructions (contact us).

## Configuring the ATH 500 M-MT pump for the application

### Pump parameter configuration

PARAMETERS	RS COMMANDS	VALUES	FACTORY CONFIGURATION
Modify the Standby speed	RPM and SBY	15 000 to 50 000 rpm	15 000
Modify the speed contact threshold	SET 30	- 3 to -50%	- 3%
Modify the thermostating threshold (only MT model)	SET 31	30 to 65 °C	65 °C*
Modify the bearing alert threshold	SET 32	0 to 100%	20%
Remote mode	OPT 14	0 : Keyboard (HHR) 1 : Remote 2 : RS 232 5 : Profibus **	1 for standard pump or 5 for Profibus
Inhibition mode	OPT 25	0 : inactive 1 : active	0
Thermostatage mode	OPT 29	0 : inactive 1 : active	0 : for ATH 500-M 1 : for ATH 500-MT
Contact mode	OPT 33	0 : Rotating 1 : Accelerating	0

\* Depends on the pump model

\*\* Only with Profibus option

### RS232/RS485 serial link settings

PARAMETERS	RS COMMANDS	VALUES	FACTORY CONFIGURATION
Transmission speed	-	-	9600 bauds
Data length	-	-	8 bits
Parity	-	-	None
Number of STOP bits	-	-	1 bit
Data separating characters	SEP	0 to 255	44 (comma)
Number of controller in a link	ADR	0 to 255	0
Authorize transmission on STA at pre-set intervals on the serial link, when ON is set	DLR	ON or OFF	OFF
Set interval transmission	DLI	0 to 4 min 15s or 255 s	0 mn 1s



## Detailed description of RS 232 and RS 485 commands

### Conventions applicable to the syntax of all commands

Status values  
Error messages

**adr** = address, from 000 to 255  
**<CR>** Carriage Return (ascii 13)  
**OK** : command executed correctly  
**Err0** : adjustment error (out of bounds)  
**Err1** : command error (syntax)  
**Err2** : parameter error (e.g. non-hexadecimal character)  
**Err3** : context error  
**Err4** : checksum error

### \*ADR

#### Specifies the address of the device for networking

#### Syntax

#adrADR,aaa<CR>  
 adr = address of the device before the command  
 aaa = new address of the device  
 condition :  $000 \leq aaa \leq 255$

#### Result

#aaa,OK ou Err2

This command is used to allocate a specific number to each of the products making up a network.

Note: it is important to note down the number allocated to each device.

### DEF

#### List of the faults

#### Syntax

#adrDEF<CR>  
 List of the faults historic and of the active faults.

#### Result

#adr,OK if there is no fault

### \*DLI

#### Defines the DataLogger transmission interval

#### Syntax

#adrDLIxxx<CR>  
 xxx: DataLogger send interval in seconds  
 condition:  $001 \leq xxx \leq 255$

#### Result

#adr,ok or Err2

See also : DLR

Note: if ok, the interval sent is stored in user memory.

### \*DLR

#### Enables DataLogger operation

#### Syntax

#adrDLR<CR>

See also: DLI, SEP, STA

The main characteristics of the pump and its controller (see also STA command) are sent over the RS link, at the rate defined by the DLI command.

Note: any new characters arriving on the serial port (RS 232) will cancel the automatic DataLogger transmission.

\* Only for RS 232

## Detailed description of RS 232 and RS 485 commands

---

### ECH Enables or disables command echoing

---

**Syntax**

#adrECHON<CR>  
enables all characters received to be echoed over the serial port (RS 232 only).  
or  
#adrECHOFF<CR>  
disables all characters received from being echoed over the serial port.

**Result**

#adr,ok  
  
Comment:  
- This command is disabled in RS 485 operation, the value OFF is required.

---

### IDN Identifies the device which is communicating, and its software version

---

**Syntax**

#adrIDN<CR>

**Result**

#adr, ATH500M - Vx.yy.zz  
  
Returns the type and the software revision of variable drive supervisor.

---

### LEV10 Returns the state of the parameters defined by SET

---

**Syntax**

#adrLEV10<CR>

**Result**

#adr,nnnnn,sssss,00000,0,cccc,eeee,00000,0000,0000,ij,kk,III,mmm

Returns current values:

- nnnnn** : nominal speed set point (in rpm)
- sssss** : stand-by speed set point (in rpm)
- cccc** : pump working time (in hours)
- eeee** : electronic working time (in hours)
- ij** : speed threshold for relay (3 to 50%)
- kk** : temperature set point (30 to 65%)
- III** : bearing threshold (0 to 100%)
- mmm** : bearing current value (0 to 100%)

Note: 0 = not used

---

### NSP Switches the speed set point to the nominal speed value

---

**Syntax**

#adrNSP<CR>

**Result**

#adr,OK  
  
The speed set point for the pump is set to its nominal value.

## Detailed description of RS 232 and RS 485 commands

### OPT

Used to select possible user choices

Syntax

#adrOPTxx,n<CR>

Result

#adr,OK

xx = OPTION OF PARAMETERS	n = value
14: Remote mode	n = 0 : Keyboard (for HHR) n = 1 : remote hard (give control to remote) n = 2 : serial link (give control to RS 232/485) n = 5 : Profibus
25: Inhibition mode	n = 0 : inactive n = 1 : active inhibition (the controller doesn't supply the motor)
33 : Contact mode	n = 0 : ROTATING (closed contact if speed>120rpm) n = 1 : ACCELERATING (closed contact in phase of progress)

### RDI

Returns the serial number of the product

Syntax

#adrRDI<CR>

Result

#adr,A123456789<CR>

### RPM

Defines the speed set point in stand-by value

Syntax

#adrRPM, nnnnn<CR>

Result

#adr,OK or  
#adr,ErrX

X = 1: out of range  
X = 2: parameters  
X = 3: context (not in standby mode)

### SBY

Switches the speed set point to the stand-by value

Syntax

#adrSBY<CR>

Result

#adr,OK

Resets the stand-by speed to its Standby stored value, and allows it to be modified if a «RPM» command is sent.  
This configuration is automatically stored in user memory.

## Detailed description of RS 232 and RS 485 commands

---

### SEL10 Returns the state of the parameters defined by OPT

---

**Syntax** #adrSEL10<CR>

**Result** #adr,0,0,1,0,r



r: Returns remote mode choice  
 r=0: keyboard  
 r=1: remote hard  
 r=2: serial link  
 r=5: Profibus

**Result** #adr,OK

Note: 0 = not used  
 1 = not used

---

### SEL 20 Returns the state of the parameters defined by OPT which are not defined in SEL 10

---

**Syntax** #adrSEL20<CR>

**Result** #000,a,b,c,d,e,f,g,h,i,j,k,l,m,n,o,p,q,r,s,t,u,v,w,x,y,00,11,22,33,44,55<CR>

f :opt 25  
 j :opt 29  
 n :opt 33

---

### SEP Defines the character which separates the parameters in a reply

---

**Syntax** #adrSEP,nnn<CR>

nnn: 3-digit decimal value of the ascii code of the desired character (with leading zeros).  
 condition: 000 ≤ nnn ≤ 255

**Result** #adr,OK or #adr,ErrX if error

Allows the user to select the character which separates the parameters returned by the **DLR STA** and **LEV** commands.  
 Default value: comma «,» ascii code = 044  
 If ok, the selected value is automatically stored in user memory.

---

### SET Defines the internal operating parameters

---

**Syntax** #adrSET10,cccc<CR>: utilization time of the pump (in hours)  
 #adrSET30,jj<CR>: speed threshold for relay (3 to 50%)  
 #adrSET31,kk<CR>: thermostating threshold (30 to 65 °C)  
 #adrSET32,lll<CR>: bearing threshold (0 to 100%)  
 #adrSET33,MMM<CR>: bearing current value (0 to 100%)

**Result** #adr,OK or ErrX

## Detailed description of RS 232 and RS 485 commands

### STA

#### Syntax

#### Result

Returns the status of the internal dynamic parameters

#adr**STA**<CR> or **STA**<CR>

#adr,sss, rrrr, vv, www, xxx, yyy, zzz, aa, bbbbb, ccc, ddd, gggggggggggggg  
321  
 gggggggggggg<CR>

**adr:** adress

1 <sup>SSS</sup>

**s1:** order status

Bit	7	6	5	4	3	2	1	0
		INH	LOCAL	STOP	(serial link)	REM	STDBY	START
0		OFF	OFF	OK	OFF	OFF	OFF	OFF
1	1	ON	OK	fault	ON	ON	ON	ON

2 <sup>SSS</sup>

**s2:** pump status

Bit	7	6	5	4	3	2	1	0
		Fault	Warning temp	Braking	Nom. speed and Temp	Accelerating	Start	Power
0		OK	OK	OFF	OFF	OFF	OFF	
1	1	fault	warn.T	ON		ON	ON	ON

3 <sup>SSS</sup>

**s3:** valve status

Bit	7	6	5	4	3	2	1	0
		At speed	(free)	(free)	Water valve	Thermostat	Air inlet	Isol. valve
0		OFF	OFF	OFF	close	OFF	close	close
1	1	ON	OFF	OFF	open	ON	open	open

rrrr: speed in rpm

vv: Radial

www: Radial

xxx: Radial

yyy: Radial

zzz: Axial

aa: Current voltage in V

bbbb: Current Value in mA

ccc: Pump temp (° C)

ddd: Electronic temp (° C)

sss : needs to be converted from ASCII to binary

123

## Detailed description of RS 232 and RS 485 commands

STA  
(continued)

Returns the status of the internal dynamic parameters  
(continued)

g	0 = OK	1 = ALERT	2 = FAULT
0	0		
1	0		
2	0		
3	0		
4	0		
5	0		over-current/sensor
6	0		
7	0		mag. suspens.
8	0	Power voltage	
9	0		
10	0		Yh radial
11	0		Xh radial
12	0		Yb radial
13	0		Xb radial
14	0		Z axial
15	0	bearing	Bearing change
16	0	electronic temp.	Electronic temp.
17	0	pump temp.	Pump temp.
18	0		
19	0		
20	0		Self check
21	0		
22	0		
23	0		
24	0		

### TMP

#### Syntax

**Defines the operating state of the turbomolecular pump**

#adrTMPON<CR>: start pump rotation

#adrTMPOFF<CR>: stop pump

#### Result

#adr,OK or #adr,Err3 if the pump is already in the state requested  
(context error)

### VER

**Defines the version of electronics «extension» + «frequency converter» + «magnetic bearing»**

#### Syntax

#adrVER<CR>

#### Result

#adr,Interface : VX.YY.ZZ, cartridge : VX.YY, Type XXXXX<CR>

Interface VX.YY.ZZ:

interface board software version (Front panel)

Cartridge : VX.YY :

interface board software version

Type:xxxxx

type of connected pump (code)



# Maintenance

---

ATH 500 M - MT User's Manual

## Detailed contents

**D 100**

*Safety instructions for product removal*

---

**D150**

*Maintence frequency*

---

**D 200**

*Diagnosis and Troubleshooting*

---

## Safety instructions for product removal

### WARNING

- Maintenance must be performed by a skilled maintenance operator trained in the relevant health and safety aspects (EMC, electrical hazards, chemical pollution, etc.).  
Isolate the product from all energy sources (mains electricity, compressed air, water, gas ...) before starting work.
- Standard precautions before any maintenance operation:  
Before performing a maintenance operation, stop the pump. When the pump is at rest, switch off the pump by setting the controller main switch to «0», wait 5 minutes before disconnecting the main cable. If this last one remains connected, some components will still be energized.  
Be sure that the controller status is visible from the operator otherwise disconnect the cable from the pump.
- Risk of injury by cutting:  
The inlet of the pump mustn't be disconnected as long as the rotor is moving and without having disconnected the power line cable.
- After pumping on corrosive or toxic gases, it is strongly recommended to seal the pump with blanking plates in case of return to the repair service centers (  E 100). Don't forget to label in a visible way the product for the operator.

### DANGER

- Risk due to pumping conditions:  
Remaining process gases in the pump may cause severe injury or death. Before removing the pump from the installation, continue N2 flow from the process tool for 30 min. Nitrogen pressure and flow rate should be identical to the programmed values during process.
- Chemical supplies coming from the tool, as well as the water and the nitrogen need also to be locked out / tagged out.
- During pump removal, operator could be in contact with process residues on the inlet and exhaust ports which could cause severe injury or death. Ask your safety department for instructions according to the local regulations.



## Safety instructions for product removal

Users are advised:



Wear gloves, protective glasses, any appropriated safety equipment.  
Ventilate the premises well.

Do not eliminate maintenance waste via standard disposal channels. Have it destroyed by a qualified company if necessary.

Install the inlet and exhaust blanking plates, thus delivered with the pump or available as accessories (  E100 ) .

The outside of the product and control box can be cleaned with a lint free wiper. Avoid using cleaning products that deteriorate printed surfaces and self adhesive labels. All other cleaning operations must be done by our service centers.

### Decontamination – product dismantling

According to the regulations 2002/96/CE about Waste of electrical and electronical equipments, and 2002/95/CE about Restriction of Hazardous substances, the manufacturer provides a recycling paid service for the end-of-life of waste electrical and electronic equipment.

Any obligation of the manufacturer to take back such equipment shall apply only to complete not amended or modified equipment, using adixen Vacuum Products original spare parts, delivered by adixen Vacuum Products, containing i.e. all its components and sub-assemblies.

This obligation will not cover the shipping cost to an adixen Vacuum Products service center.

Before returning the product, fill in the safety form, attach it to the product before shipping to the service-repair office closest to you.

How to contact us ?

The overhaul must be performed by manufacturer's trained personnel. Contact nearest service center or the service support at the following e-mail address: [support.service@adixen.fr](mailto:support.service@adixen.fr)

## Maintenance frequency

### Back-up ball bearings

When the pump is running, the rotor is levitated magnetically. There is therefore no friction between moving and fixed parts.

The rotor remains levitated by magnetic ball bearings.

Only the back-up ball bearings require maintenance: they are designed to withstand many accidental shut-downs, or many landings of the rotor on the ball bearings at full speed.

These accidental shut-downs occur only in exceptional circumstances: broken power supply cable, strong shocks, faulty electronics. It is advisable to check the bearing counter and provide ball bearing maintenance, when needed.

Back-up ball bearings are designed to withstand abnormal landings at full speed.

### The bearing counter

The wear of the back-up ball bearings is internally monitored by the controller, based on the rotation speed and the landing duration.

Initial percentage value is set at 100%. When this percentage reaches 0%, an alarm is generated, pump can't restart, and back-up ball bearings need to be replaced by authorised Service Center.

### Warning messages for pumps maintenance

The ball bearing alert threshold can be set on the menu (  C300).

The internal memory of the controller also informs the operator when the ball-bearings require maintenance (  D200).

#### CAUTION

The life time of the rotor is at least 5 years under normal conditions with clean process. Please contact the Service Center to check your application.

The full overhaul must be performed by manufacturer's trained personnel.

Only inlet screen, coil or pump valve replacement are authorized at the customer's site.

Contact the nearest service center or the service support at the following e-mail address: [support.service@adixen.fr](mailto:support.service@adixen.fr)

## Diagnosis and troubleshooting

INCIDENT	CAUSE	REMEDY
No event occurs after power on	<p>No mains current</p> <p>Isolate the product from the various energy sources before any maintenance operations.</p>	<ul style="list-style-type: none"> <li>■ Check that the pump is powered by a 48 V DC power supply (the blue lit lights on).</li> <li>■ Check the remote control configuration of the pump (📖 C800 : SEL10).</li> <li>■ Contact the Customer Service.</li> </ul>
During the speed rise, the pump starts to vibrate	Abnormal working	<ul style="list-style-type: none"> <li>■ Check that the pump is rigidly fixed to the frame;</li> <li>■ Check that there are no vibrations on the pump frame;</li> <li>■ Check that the attachment screws are correctly fastened (problem can be caused by an anti-vibration flagstone);</li> <li>■ Contact the Customer Service.</li> </ul>
The red light (on the front panel) lights on	The pump is faulty	<ul style="list-style-type: none"> <li>■ Connect the serial link;</li> <li>■ Enter the command: #DEF (📖 C800);</li> </ul> <p>Example of faults</p> <ul style="list-style-type: none"> <li>- unbalance fault</li> <li>- magnetic bearing</li> <li>- displacement fault</li> <li>- over temperature</li> </ul> <p>Example of warnings</p> <ul style="list-style-type: none"> <li>- int. comm</li> <li>- power volt</li> <li>- OBC temp.</li> </ul> <ul style="list-style-type: none"> <li>■ Enter the command : #LEV10 (📖 C800)</li> <li>■ Switch off then switch on the power supply;</li> <li>■ If the fault persists contact the customer service.</li> </ul>



# Maintenance instructions

---

## ATH 500 M-MT Operating instructions Detailed contents

E 100

*Shipping procedure for contaminated pumps*

---

- Inlet port
- Exhaust port
- Purge port
- Exhaust port (pressurisation)
- Rough decontamination procedure

## Shipping procedure for contaminated pumps

Don't forget to fill in the «safety questionnaire» and return it to repair service center (see model of document at the end of the manual).

### WARNING

Study the safety instructions related to preventive maintenance  D 100.



The user must stick this label on the product to warn against pumped process gas that could be dangerous and toxic and could cause severe injuries or death. It specifies that any preventive maintenance operation can only be performed by trained personnel.

Whenever you return the product to an adixen repair service center, you must comply with the requirements of the «Procedure for returning adixen products», fill in the safety questionnaire available in appendix  G200 of the user's manual.

### WARNING

Risk of injury by cutting.  
Contact with the pump rotor cell may cause cuts. Alternatively, protective gloves may be worn when servicing the product.

Pumps to be shipped must initially be decontaminated then pressurized with dry nitrogen (see procedure sheet 3/3).

To achieve this the user must have the following connection accessories:

Ⓐ

### Inlet port

Closing kits including o-ring, screws and nuts inlet blank flange and hoisting rings can be supplied upon order. For other inlet part types contact the customer service.

Closing kit	DN160 ISO F	DN160 ISO K	DN100 ISO K
P/N	114501	114502	118377

## Shipping procedure for contaminated pumps

### Ⓑ Exhaust port\* DN25 / DN40 ISO-KF

Description	DN 25	DN 40
Centering ring with seal	068189	068194
DN 25 Clamping ring	083264	083267
Blank-off flange	068196	068197

### Ⓒ Purge port

Description	P/N
Plug 1/8"BSPP	1152985

### Ⓓ Exhaust port (pressurisation)

Description	DN25	DN40
1/8 BSPT Flange with anti-suckback valve	114419	065053
Injector	106859	



### Characteristics of filtered dry nitrogen supply

A filtered dry nitrogen supply with the following characteristics is required:

- Dew point < 22°C
- Dust < 1µm
- Oil < 0.1 ppm
- Absolute pressure of 1 to 1.2 bar.

### Rough decontamination procedure

The pump must be disconnected from its installation and isolated electrically.

### **⚠ DANGER**

**Install the pump under an extractor hood.  
It must remain there throughout the operation.**

### 1 General flushing

Fit the DN 25 blank flange with anti-suckback valve on the exhaust port.

Flush with dry nitrogen using the injector at an absolute pressure of 1.1 to 1.5 bar for 30 minutes.



\* Standard connection accessories available in the manufacturer's product catalog.

## Shipping procedure for contaminated pumps

### 2 Pressurize the pump

Blank the inlet port and the  
purge port.

Pressurize the pump with  
dry nitrogen to an absolute  
pressure of 1.1 bar using the  
injector.



10'





# Maintenance components

---

## ATH 500 M-MT Operating instructions

### Detailed contents

F 000

*Spare parts - Instructions of use*

---

F200

*First level of maintenance needed*

---



---

## Spare parts - Instructions of use

### Replacement of parts and use of non genuine parts

Our products are designed to comply with current EC regulations and guarantee optimal operating conditions with maximum safety conditions for the user.

**Any modification of the product made by the user is liable to lead to non-compliance with the regulations, or even to put into doubt the performance of the product and the user's safety.**

Replacement of defective components with parts that are not genuine, jeopardizes the initial safety conditions of the equipment.

**In such cases, the EC declaration of conformity becomes null: The manufacturer withdraws responsibility for such operations.**

Besides, counterfeiting and unfair trading of parts are condemned under civil and criminal laws.

The manufacturer urges the user not to use «imitation parts», or the misappropriation and pirating of intellectual property performed by some dishonest operators.

The manufacturer supplies maintenance components, spare parts or kits to perform the maintenance of its products (  F).

## First level maintenance parts

**For air inlet  
and purge valve**

	P/N
Coil 24 V DC	<b>038066</b>

**Dust filter** Replace regularly the dust filter  
when used in dusty air

	P/N
Dust filter	<b>106229</b>

**Electrical cable of the air  
cooling device**

	P/N
Cable	<b>A464597</b>

A complete range of connecting accessories is available in the manufacturer's catalogue (flanges, fittings...).



# Appendix

---

## ATH 500 M-MT User's Manual Detailed contents

**G 100**

*Declaration of conformity*

---

**G 150**

*Pumping curves*

---

**G 200**

*Safety Questionnaire*

---

**G 1000**

*Hand Held Remote (HHR)*

---

## adixen

### DECLARATION OF CONFORMITY

We, Alcatel Vacuum Technology France,  
98, Avenue de Brogny, BP 2069  
74009 ANNECY FRANCE

**ISO 9001 CERTIFIED**

declare under our sole responsibility that the Adixen pump

**ATH 500 M**

to which this declaration relates are in conformity with the following European Directives and Standards :

**1998 / 37 / EEC MACHINERY DIRECTIVE**

**2006 / 95 / EEC LOW VOLTAGE DIRECTIVE**

NF EN 61010-1 Safety requirements for electrical equipment for measurement, control and laboratory use

**2004/ 108 / EEC ELECTROMAGNETIC COMPATIBILITY**

NF EN 61000-6-2 EMC / Generic immunity standard / Industrial environment

NF EN 61000-6-4 EMC / Generic emission standard / Industrial environ  
Class A - group 1

This product complies with the requirements of the above Directives and carries the CE marking.

Mr J.Y. GUEGAN,  Président Directeur Général

Annecy, le 24/03/09

LANGUE : ANGLAIS

## Pumping curves

ATH 500 M-MT DN100 ISO-F with inlet screen (without purge)

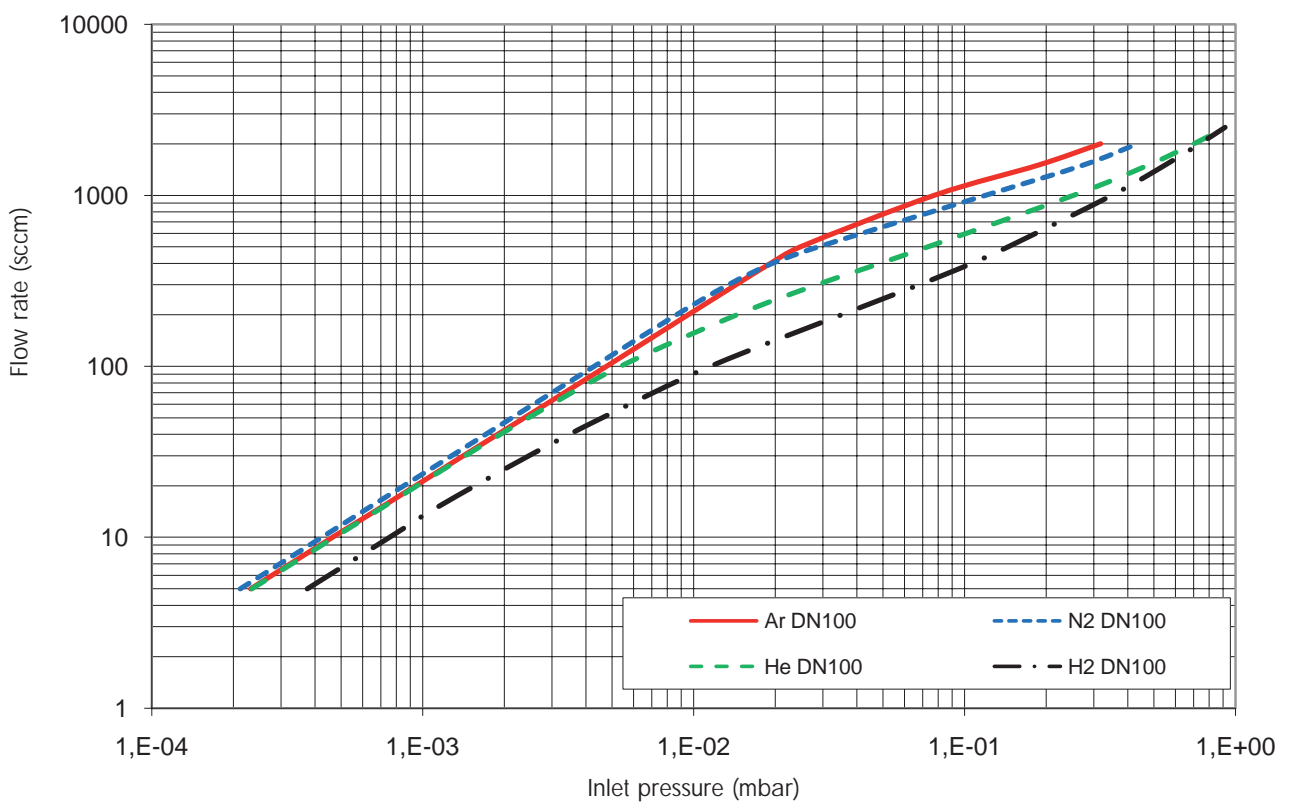
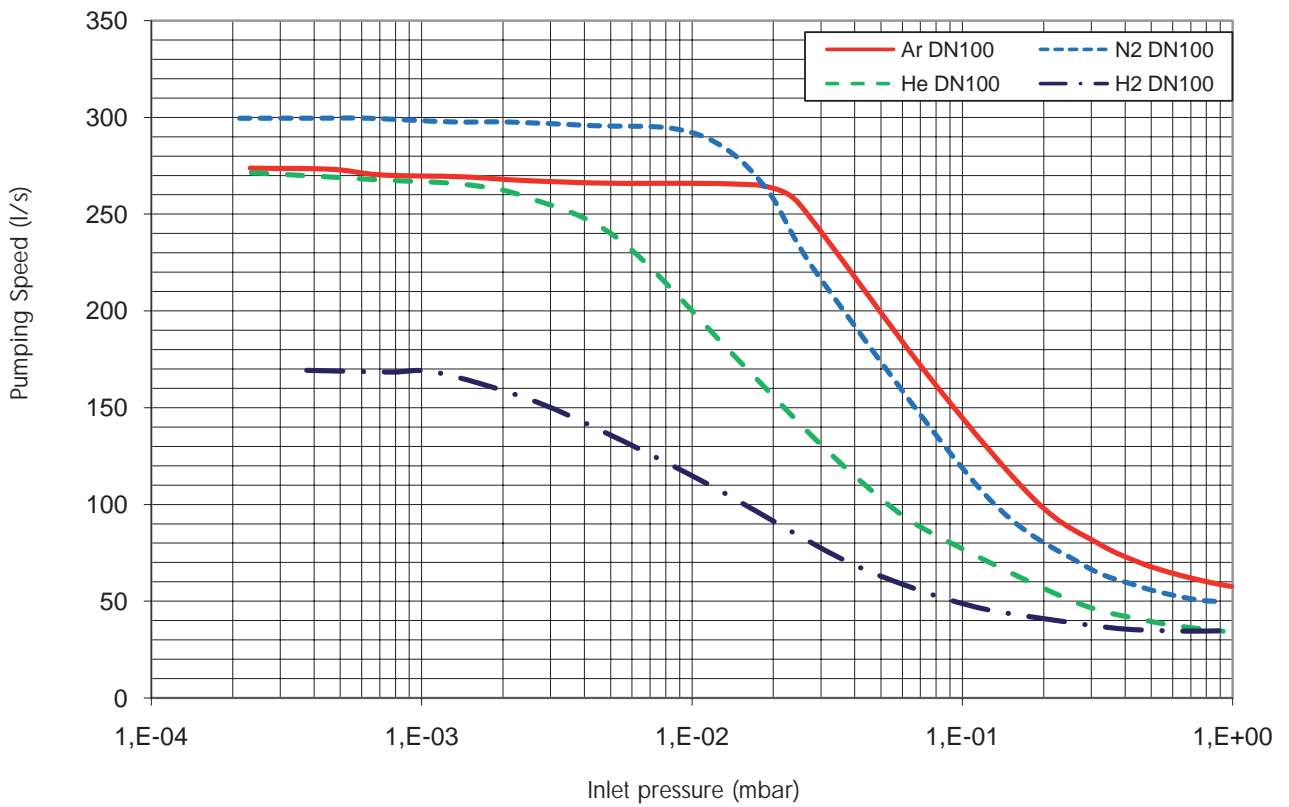

## Pumping curves

ATH 500 M-MT DN160 ISO-F with inlet screen (without purge)

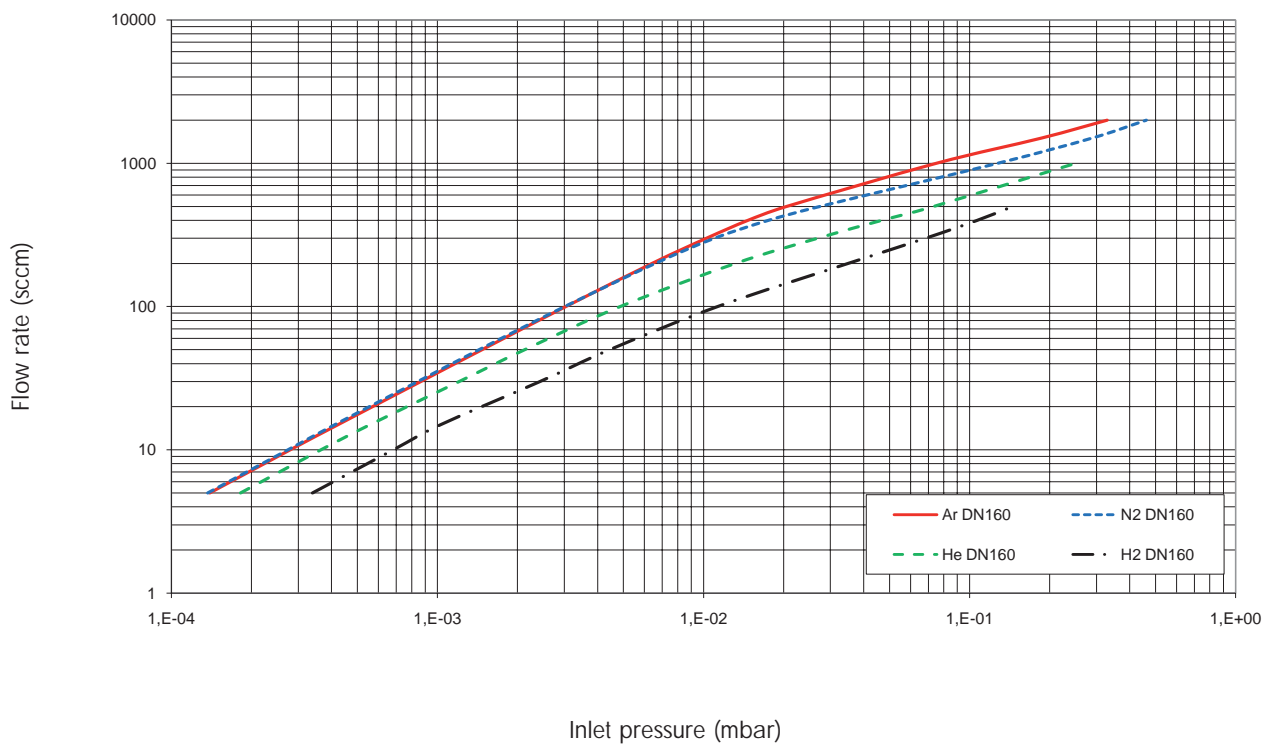
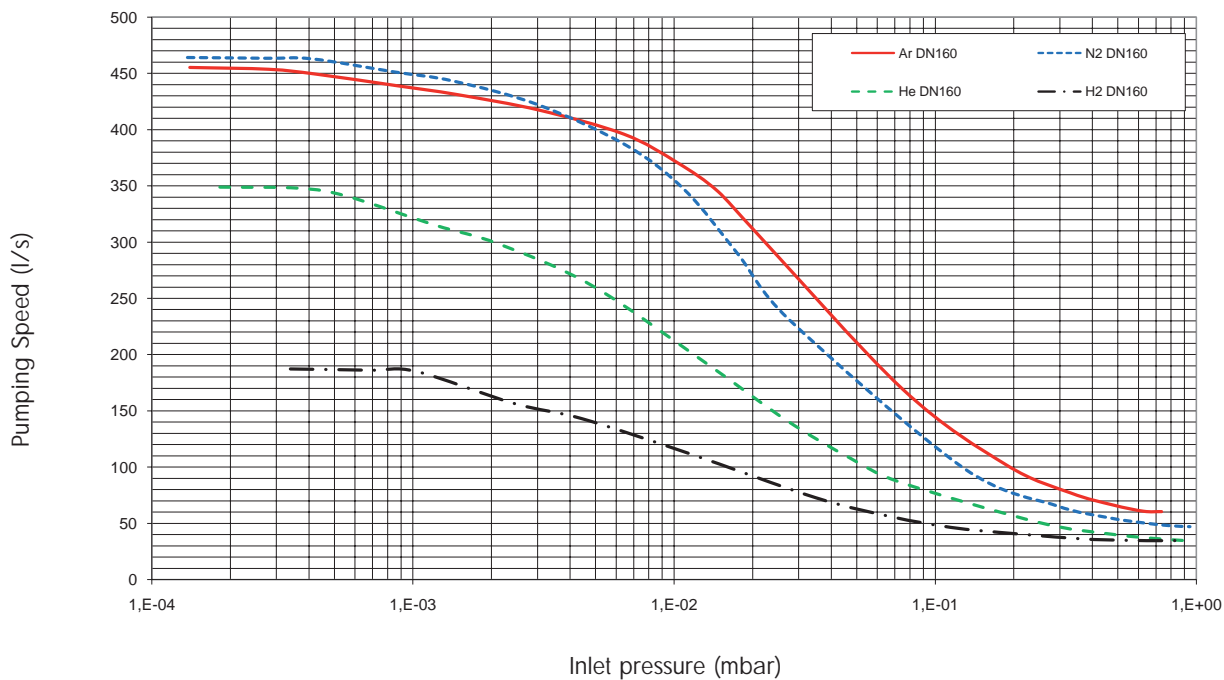

## Pumping curves

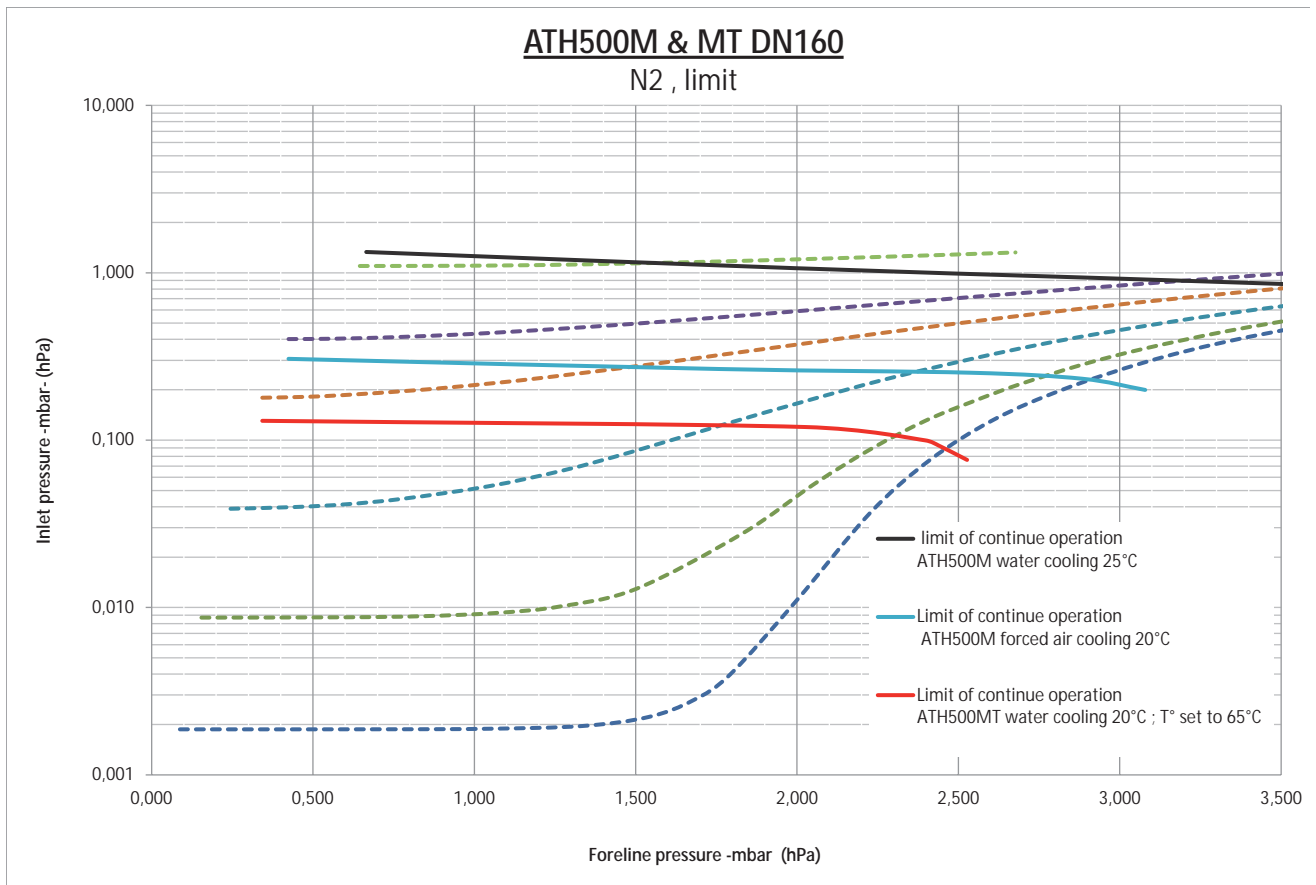

## Declaration of contamination

### Procedure for returning products

You wish to return an adixen product for maintenance. The equipment will be dismantled and possibly cleaned by a technician from our service centre.

Pfeiffer Vacuum requires this form to be completed to preclude the potential health risk to its service personnel that can occur when receiving, disassembling, or repairing potentially contaminated products.

**Please fill in the present declaration of contamination, print it and attach it to the product before shipping to your closest service center.**

**Equipment returned without this form fully completed, and secured to outside of package, will be returned to customer unprocessed, at his cost.**

**If following inspection and quotation, customer elects to not proceed with repair, he will be subject to service fee to cover product decontamination, disassembly, cleaning and evaluation costs.**

Please contact service centre for any further recommendations.

#### We wish to draw your attention to the following points:

Equipment must be drained of fluids and residue, securely packaged and shipped prepaid. Concerning the closing of the ports (inlet and outlets of the product), metallic airtight blank flanges should be used if toxic or copper gases have been pumped.

The risk may be of the following nature:

- **Chemical:** Danger to health, risks of explosion, fire, risks for the environment. Please indicate the chemical formula and name of the gases or substances that have been in contact with the equipment (pump, detector, gauge or accessory).
- **Biological:** In case of contamination (such as pathogenic germs, micro-organisms (bacteria, viruses, etc.) classes 1 to 4 and group E), we are currently unable to decontaminate and recycle such material without risk to the safety of our staff. **Please contact us before sending the product** to the service centre.
- **Radioactive:** In case of contamination, our service center is currently unable to decontaminate and recycle such material without risk to the safety of our staff. A written evidence of decontamination will be requested prior to any service action. **Please contact us before sending the product** to the service centre.
- **Copper contamination:** Copper based by-products formed in sputtering or etching processes are considered as a poison in some semi-conductor processes. A specific treatment is required, which generates extra cost.

### WARNING

**In the event of chemical contamination, please indicate the following gases or substances:**



- Gases (or substances) introduced into the reactor and which may be found at the exhaust **(A)**.
- Gases (or substances) resulting from the reaction or process **(B)**.
- Gases (or substances) that may possibly be formed inside the pump (due to a thermodynamic or chemical reaction, condensation, deposition, precipitation, etc.) **(C)**.





## Hand Held Remote for ATHM controller

### Hand held remote description

The keyboard is used to control the pump and configure the parameters.

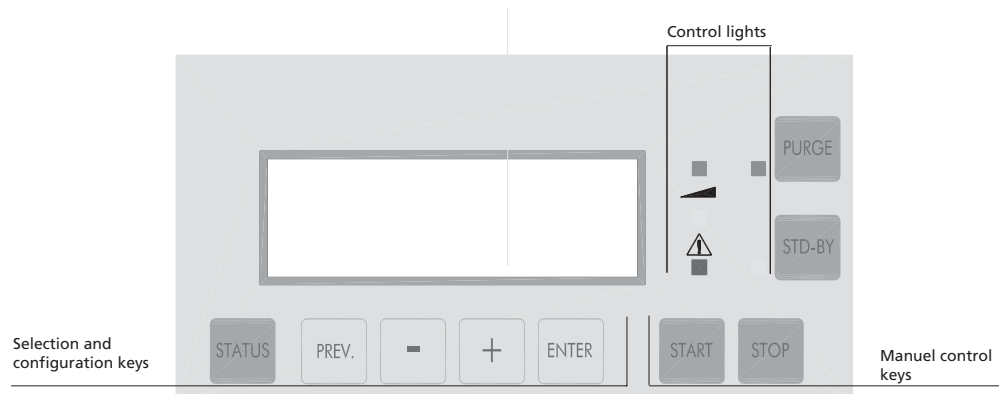

### The function of the parameter selection and configuration keys

Symbol	Description	Functions
	Parameter setting mode access key	<ul style="list-style-type: none"> <li>Press to access the parameter setting mode</li> <li>Press to exit the various menus without validating the functions</li> </ul>
 	Selection keys	<ul style="list-style-type: none"> <li>Press to move to:                             <ul style="list-style-type: none"> <li>the next or the previous menu</li> <li>the next or the previous parameter in the displayed menu</li> </ul> </li> <li>Press to select or adjust the value of the previously selected parameter</li> </ul>
	Configuration validation key	<ul style="list-style-type: none"> <li>Press to validate the selection of a menu, a parameter or a value</li> <li>Press to validate an answer to a requested information</li> </ul>
	Display access key	<ul style="list-style-type: none"> <li>Press to leave the setting menu and display the pump parameters</li> </ul>

Note: to modify the display contrast, press by holding down the Status key and adjust the value with the + / - keys.

A membrane protects the keys. Make selection by hand only and do not use hard objects such as pens, screwdrivers, etc..., which could damage the keys.

Fast scroll can be obtained by holding down the + / - keys. For all the other keys, press several times.

## Hand held remote start up

Before using the HHR, check that the electrical connections have been made between the pump and the controller (refer to B400).

- Connect the hand held remote to the controller on «Service connector».
- Supply the pump controller.

### HHR Display initialization

The initialization time is approximately 15 seconds.

The controller performs a self-test and identifies the pumps to which it is connected.



The equipment is identified, the program version is displayed, then communication test is done,

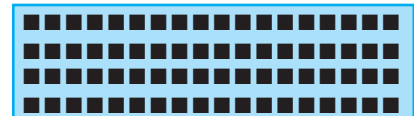

In the meantime, the Indicator lights are tested by lighting in succession.

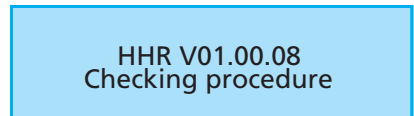

Finally, the working screen corresponding to the connected pump is displayed.

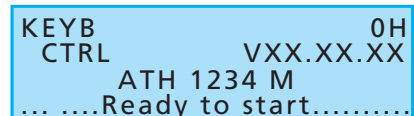
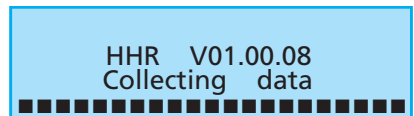

### Access to the menus

Enter the sub-menus by pressing :

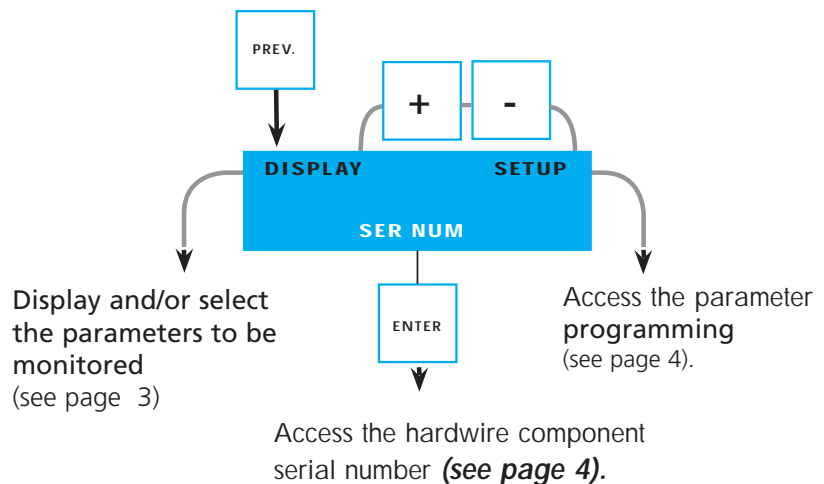

## Hand held remote - Display menu

**DISPLAY**      **SETUP**  
**SER NUM**

ENTER

- Pump and controller status
- pump temperature
  - pump motor current
  - controller temperature
  - pump rotational speed

**STATUS**    **VER**    **FAULT**  
**WARNING**    **BEARING**

**ATH 20°C**      **1.50A**  
**OBC 36°**      **34000 RPM**

ENTER

ENTER

+

- Controller version \*
- HHR version
  - Front panel version
  - Speed controller
  - DSP

**STATUS**    **VER**    **FAULT**  
**WARNING**    **BEARING**

**CTRL**      **VXX.XX.XX**

ENTER

ENTER

+

- Successive display of last 10 faults
- fault list with record number (1 to 10)
  - fault title

**STATUS**    **VER**    **FAULT**  
**WARNING**    **BEARING**

**DEF:01 15h25m30s**  
**D06 : EXTERNAL SAFETY**

ENTER

ENTER

+

- Successive display of last 10 alerts
- fault list record number (1 to 10)
  - alert title

**STATUS**      **FAULT**  
**WARNING**    **BEARING**

**War:01 20h25m10s**  
**W20 : BEARING**

ENTER

ENTER

+

- Bearing data
- the bearing life time (%) and the alert threshold (%).

**STATUS**      **FAULT**  
**WARNING**    **BEARING**

**BEARINGS**  
**100.00/20%**

ENTER

ENTER

The bearing life time  
(% remaining)

\* Display according to connected pump model.

## Hand held remote - Set up menu

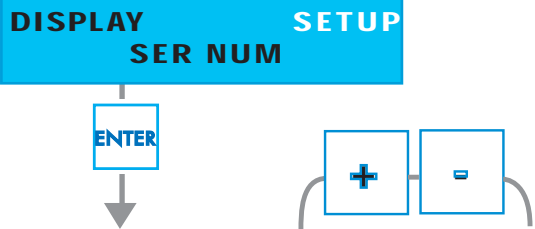

Selection	Setting limits	Initial configuration	
ACCESS CODE	0 to 65535	0	Enter the access code and validate
REMOTE CONTROL	Keyboard/Remote hard/Serial link/Profibus/DeviceNet	Profibus	Select the remote mode
STANDBY SPEED	15000 to nominal speed of the connected pump	15000	Modify the standby speed from 15000 to nominal speed
BUZZER	ON /OFF	OFF	Activate or deactivate the buzzer.
THERMOSTAT	ON = adjustable temp. from 30 to 75°C OFF	OFF	Regulate the pump temperature
RELAY AT SPEED	- 3 to - 50%	- 3	Modify the speed contact threshold.
FIELDBUS PROFILE (1)	0 or 1 (only for Profibus)	0	0 compatible with OBCV4 1 compatible with OBCV3
FIELDBUS ADDRESS	Profibus : MSB and LSD DeviceNet: ID and Data Rate	XX and YY	Display the Profibus address or DeviceNet address, data rate
RS 232 SPEED	9K6 - 19K2 / 38K4 / 57K6	9K6	Modify the RS 232 speed.
RS 232 ECHO	ON / OFF	OFF	Authorize or not authorize the echo of characters received on the link
RS 232 SEPARATOR	0-255	44	Data separating characrer (044 = comma).
RS 232 ADDRESS	0-255	0	Number of controller in a multiple link.
BEARING LIFE Warning limit	0 to 99%	20	Modify the bearing alert threshold.
NEW CODING	0 to 65535	0	Modify the access code.

\* see Pump User's manual.

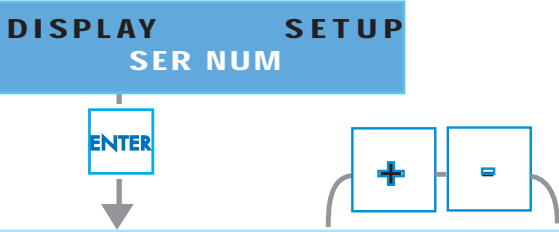

Selection	Initial configuration	
HHR	XXXXXXXXXX	Display the HHR serial number
CONTROLLER	YYYYYYYYYY	Display the front panel serial number
CARTRIDGE (2)	ZZZZZZZZZZ	Display the spindle serial number
MMCC06 (2)	AAAAAAAAAA	Display the electronical board serial number

(1) When the HHR is connected to an OBC controller (2) When the HHR is connected to an ATH 500 pump

**Leading. Dependable.  
Customer Friendly.**

Pfeiffer Vacuum stands for innovative and custom vacuum solutions worldwide. For German engineering art, competent advice and reliable services.

Even since the invention of the turbopump, we've been setting standards in our industry. And this claim to leadership will continue to drive use in the future.

**You are looking for a  
perfect vacuum solution?  
Please contact us:**

**Pfeiffer Vacuum Products GmbH**  
Berliner Strasse 43  
35614 Asslar - Germany  
T +49 6441 802-0  
F +49 6441 802-202  
Info@pfeiffer-vacuum.de  
[www.pfeiffer-vacuum.de](http://www.pfeiffer-vacuum.de)

**adixen Vacuum Products**  
98 avenue de Brogny  
74009 Annecy Cedex - France  
T +33 (0) 4 50 65 77 77  
F +33 (0) 4 50 65 77 89  
info@adixen.fr  
[www.adixen.com](http://www.adixen.com)

