

«|» GAS LINE OPTION

ASM 180TD and ASM 180TD+ only

OPERATION

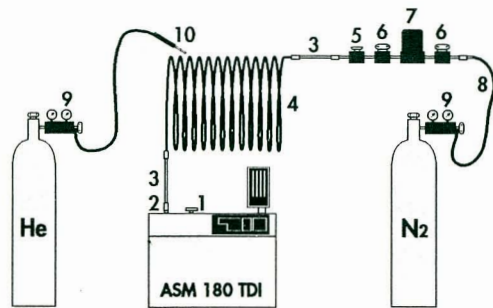

Used to perform spray testing on long lines with a reduced response time due to the transfer of the helium by a carrier gas injected in the viscous state.



CONDENSED MANUAL DETECTORS OPTIONS ASM 180T ASM 180TD

TEST PROCEDURE (SEE C 70)

Connect the installation.

Close the carrier gas supply.

Start up the detector.

Run a cycle.

Inject the carrier gas.

Calibrate the installation.



- Activate the «gas line test» function.



! The detector must remain in Fine Leak test mode (see C 70).

Test the installation.

«|» GAS LINE OPTION

DIAGNOSTIC GUIDE

The detector does not switch to Fine Leak mode.

Gross Leak on installation

Inject the carrier gas (40 SCCM) and test the installation.

The He background noise does not decrease.

The carrier gas contains helium

If He rises with the carrier gas flow: Purge the installation or change the carrier gas.

Gross Leak on installation

Test the installation.

3 MASS OPTION

SWITCH S1 CONFIGURATION (SUPERVISOR BOARD)

Tracer gas	Helium 4		Helium 3		Hydrogen	
Mass	4		3		2	
Acceleration	150±2V		198±2V		290±2V	
Voltage	see C 60		see C 60		see C 60	
Switch S1	OFF	ON	ON	ON	ON	ON
Calibration	internal	external	external	external	external	external
See sheet	E 40	E 50	E 50	E 50	E 50	E 50

INITIALISATION

Start-up

While the key  indicator light is flashing, press The red autocal key indicator light comes on.

Set the voltage
See C 60.



High Vacuum Technology

ALCATEL

INTRODUCTION AND CONNECTING

CONTROL PANEL

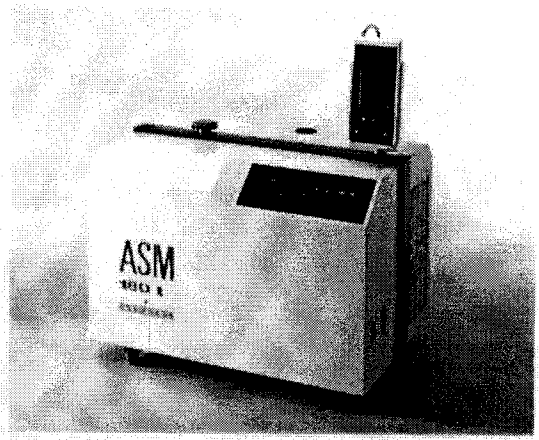
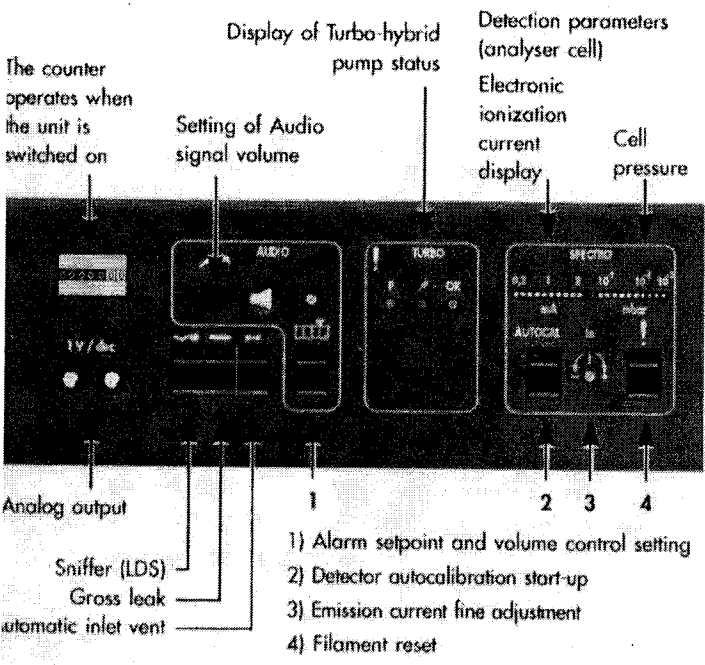

CONDENSED MANUAL
ASM 180T

REMOTE CONTROL UNIT

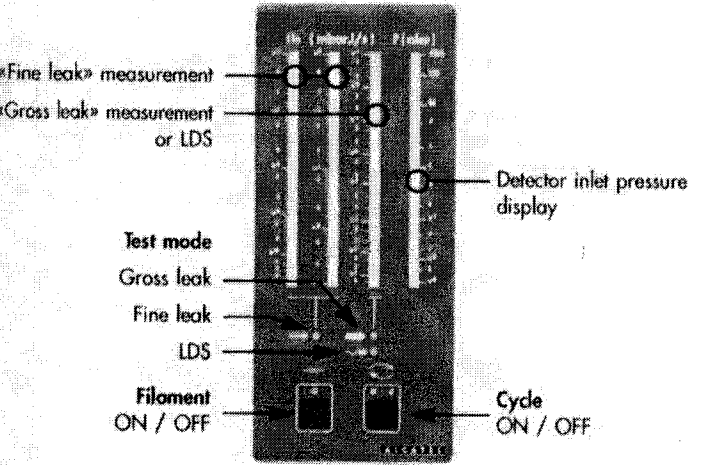

DETECTOR OPERATION

DETECTOR CONNECTIONS

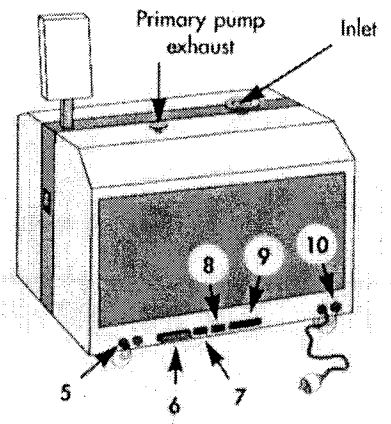

- 5) LDS probe
- 6) I/O Interface Jumper plug
- 7) RS 232
- 8) Printer (ACDP option)
- 9) Remote control unit
- 10) Atmospheric pressure vent

STARTING UP THE DETECTOR

• Set the circuit breaker switch to I

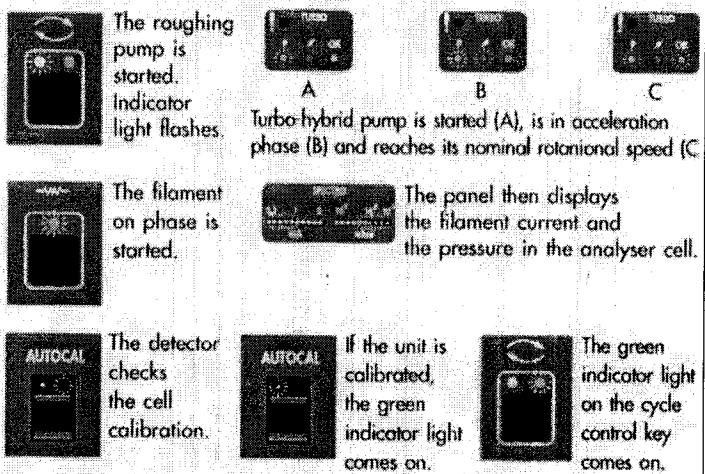

The cycle control is enabled. The detector is ready to be used.

High Vacuum Technology



DETECTOR OPERATION

USING THE DETECTOR (VACUUM TEST MODE)

• Connect the part to test

The fitting has to be done using a tubing with a sufficient diameter, and as short as possible.

• Start the detector test cycle



The cycle is started by pressing on the cycle control key. The pressure drop is shown on the display unit. The unit is placed automatically in Gross leak (GL) or Fine leak (FL) test mode. The filament must be lit for a cycle to be started.



It is possible to preset the gross leak (GL) mode by pressing on the corresponding key (cycle time reduced).

• Adjust the audio signal threshold



Pressing on the key: the threshold is displayed on the measurement displays.

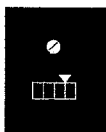

Adjust the setpoint using a screwdriver and keeping the Audio key pressed.



Adjust the Audio signal volume.

• Do the spray test

Spray helium progressively on the zones to be tested, in order to clearly locate a leak (ex.: begin from the top). Helium has to be sprayed in a small quantity using an appropriate nean (helium spray probe).

• Stop the test cycle

Press on the cycle control key again.



USING THE DETECTOR (SNIFFER TEST MODE)

• Connect the LDS probe

The probe has to be connected to the quick connector (item 5) on the rear panel.

When using an LDS extension tube, connect the probe to the female connector of the extension, and the male connector of the extension to the detector.

A longer distance between probe and detector makes the helium response time longer.

• Start the sniffer test mode

Vacuum test mode of the detector has to be off. Select the LDS mode by pressing on LDS key.



The filament shuts down a few seconds, then lits on again. The LDS light indicator  of the remote control box is on: the detector is ready for use.

• Adjust the audio signal threshold

Same operation as for vacuum test.

• Do the sniffer test

The inside of the part being pressurized with helium, examine the zones to be tested with the LDS probe nozzle.

Usually, first begin with the lower parts. The distance between the probe and the test zone, and the displacement speed have to be adapted to the size of expected leaks.

A leak is located when the helium signal reaches a clearly identified maximum.

• Stop the sniffer test

Desactivate the LDS key.



The LDS light indicator  shuts down.

RECORD THE SIGNAL



1 V / dec
Voltage of 0 to 8 V.
Logarithmic
1V per decade.

INTERVALS MAINTENANCE OPERATIONS

FREQUENCY	OPERATION	SHEET
2000 H	<ul style="list-style-type: none"> Change RVP pump oil. Replace the cartridge. 	E 10
4000 H	<ul style="list-style-type: none"> Clean the vacuum lines, the valves and the gauges. Dust the electronic boards and the fan. Clean the analyser cell. Replace the filament and the electron collector. Replace the seals on the analyzer cell and the VHS preamplifier. 	E 20
8000 H	<ul style="list-style-type: none"> Regrease the TMP 5154 pump. Replace the seals in the RVP pump. Check and calibrate the electronics and pressure gauges. Adjustments and calibration. 	Call Customer Service.
16000 H	<ul style="list-style-type: none"> Complete service of the RVP pump. 	
24000 H	<ul style="list-style-type: none"> Replace the ball bearings and the seals of the TMP 	
2 years	<ul style="list-style-type: none"> Recalibration of internal calibrated leak. 	E 40

GENERAL TROUBLE SHOOTING GUIDE

See User's Manual (Chapter D)

Condensed manual

Ed 02 - 02/96

ALCATEL
ALCATEL - High Vacuum Technology
98, avenue de Brogny - B.P. 2069 - 74009 ANNECY Cedex
Tel : 04 50 65 77 77, Fax : 04 50 65 77 89, Telex : 385 153 F