



# Alcatel ACT-250

## Technical Specifications

Characteristic	Unit	ACT 250 "box"	ACT 250 "OEM"
Weight	kg	1.8	1.3
Dimensions H x W x D	mm	128.4 × 106.3 × 220 3U × 1/4 Rack	95 × 100 × 212
Nominal voltage	V	85 - 265	
Frequency	Hz	50/60	
Maximum power	W	300	
Maximum ambient temperature	° C	T ≤ 50	
Storage temperature	° C	-15/+70	
Customer mains circuit breaker rating	A	T10A	

## Dimensions

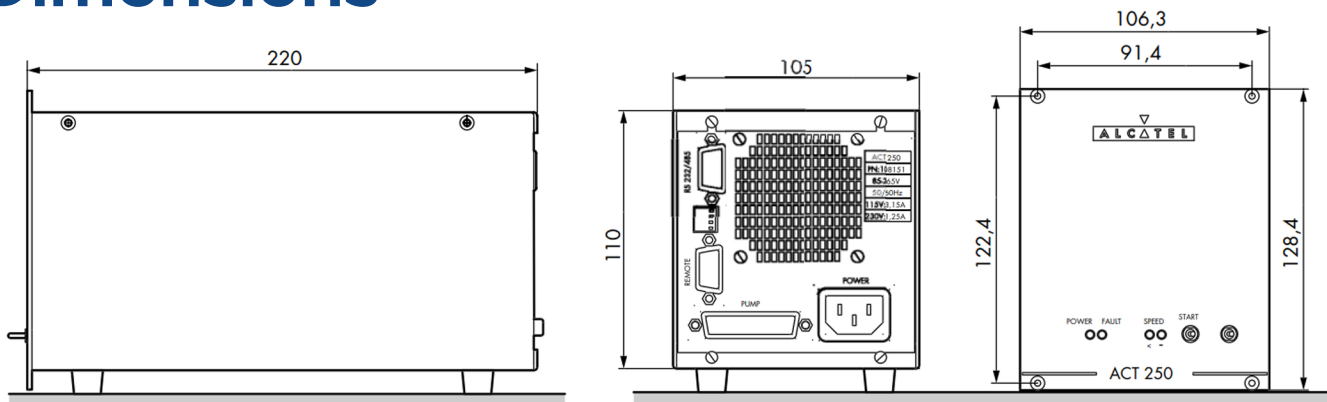

## Features & Benefits

- equipped with 4 leds (power, fault, pump starting, pump at speed)
- remote control: start, stop, standby, external safety, mode select
- powers pump motor & controls
- built-in hour counter