

ec fans & drives  
an EPEC company  
ECY-01-E-230-1450-001-A01  
1450rpm 0.25A 230VAC 50/60Hz

**ECD0299-A03**  
839, 065, 021  
DD/MM/YYYY

S1 - AO - TP - CCW - IP55  
CE cULus  
Designed in USA Assembled in China

△ DIMENSION G INCLUDES GROMMET LENGTH.

REFERENCE	NOMINAL	TOLERANCE
A	254	+/- 2mm
B	207	+/- 2mm
C	98	+/- 2mm
D	90	+/- 2mm
E	4X Ø5.00 @ PCD 242	+/- 1mm
F	8X Ø4.30 @ PCD 236	+/- 1mm
G	490	+/- 10mm
Performance	1450rpm	+/- 5%

ITEM	DESCRIPTION
1	ECY Motor - ECY-01-E-230-1450-001-A01
2	200mm Plastic Fan Ring - FRP200-H77-003-A01
3	200mm x 38° Galvanised Steel Impellor FAN200-38-S-GS-API

REVISIONS			
DATE	REV	DESCRIPTION	BY
6/30/2017	A01	DRAWING RELEASE	J.S.
8/15/2017	A02	REPLACED SWR200-S-70-001 WITH FRP200-H77-001-A01	J.S.
3/26/2018	A03	REPLACED FRP200-H77-001-A01 WITH FRP200-H77-003-A01, UPDATED DIMENSION B, UPDATED REAR ID LABEL	J.S.

UNLESS OTHERWISE SPECIFIED DIMENSIONS IN MILLIMETERS TOLERANCES ARE:  
LINEAR ± 0.15  
ANGULAR ± 0.5°

ANGLE OF PROJECTION

MATERIAL

FINISH

	NAME	DATE
DRAWN	J. SILVA	3/26/2018
CHECKED		
ENG APPR.		
MFG APPR.		
Q.A.		

PROPRIETARY INFORMATION  
THESE DRAWINGS & SPECIFICATIONS ARE PROPERTY OF EC FANS & DRIVES AND SHOULD NOT BE COPIED, REPRODUCED, OR USED AS THE BASIS FOR SALE OR MANUFACTURE OF APPARATUS OR DEVICES WITHOUT WRITTEN PERMISSION.

ec fans & drives  
an EPEC company

TITLE  
ECY-01-E-230-1450-001-A01  
200mm Fan Assembly

SIZE  
B

DRAWING NO.  
ECD0299-A03

SCALE: 2:5 DO NOT SCALE DRAWING SHEET 1 OF 1

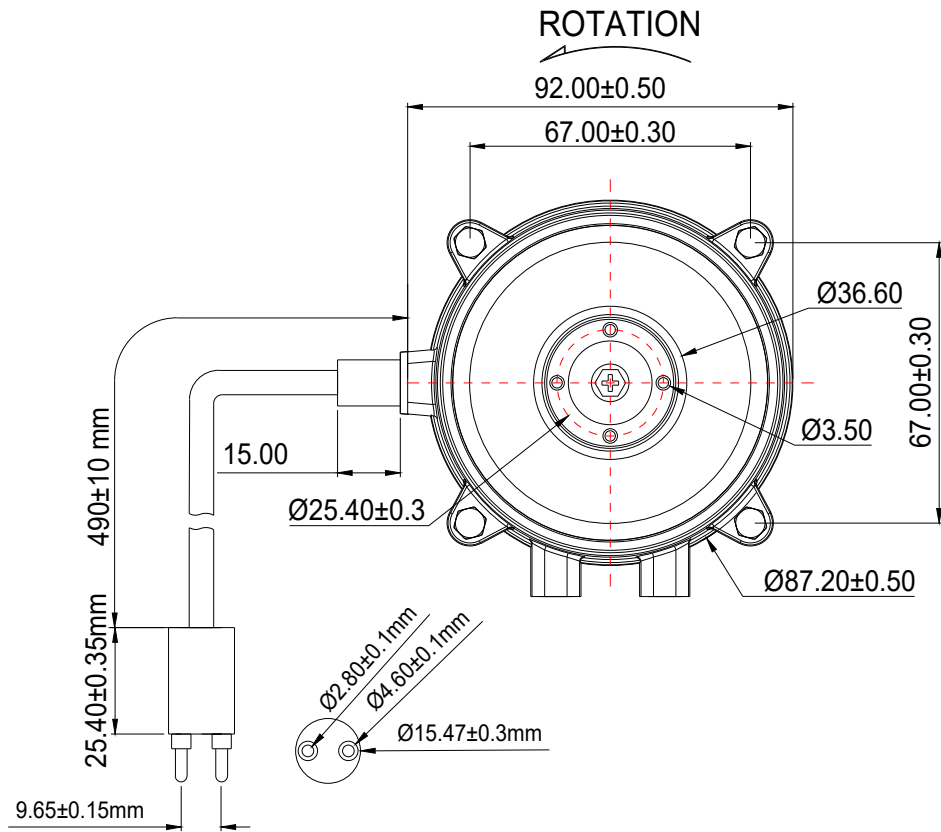

Cable Part Number BTHK105-0166 (Rev B)

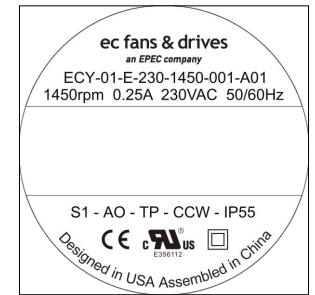
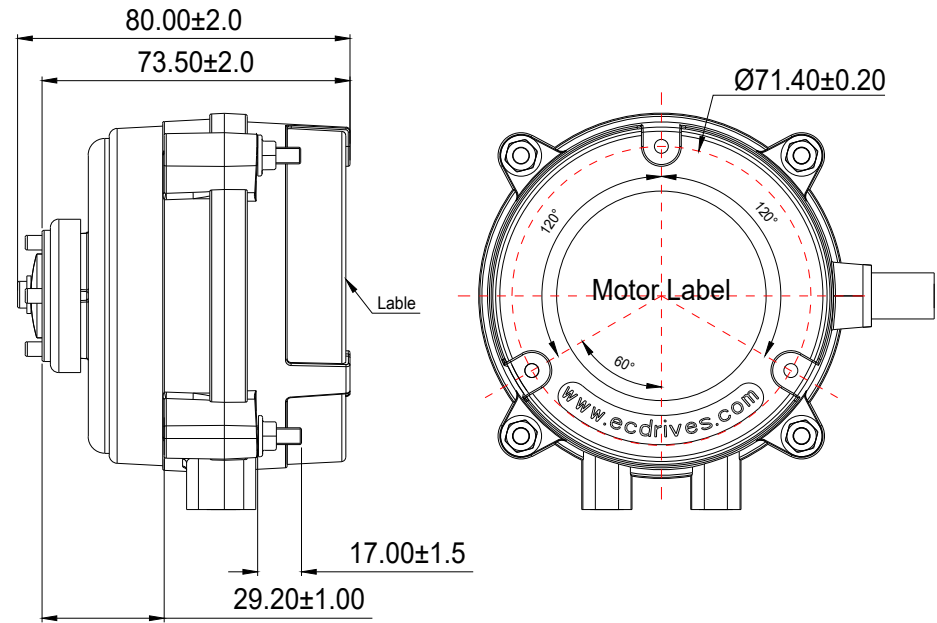

Rotation Speed	1450rpm	Motor Type	EC Motor	<b>EC FAN &amp; DRIVES</b>				RoHS	
Max Current	0.25A	Operating Temp	-40°C to +50°C					Date	2017/5/30
Operation Voltage	230VAC (50/60Hz)	Motor Protection	IP55					Revision	A01
Speed Control	Constant Speed	Life Expectancy	40,000hrs	Scale	1:1	Drawn	HQM	<b>PART NUMBER</b> ECY-01-E-230-1450-001-A01	
Insulation Class	Class B (130°C)	Case Material	PBT			Checked	ZXL		
Rotation Direction	CCW	Weight	645g	UNIT	mm	Approved	GZF		

**EC fans & drives**

**ECD0299-A03 200mm Fan Assembly**

<b>Customer :</b> Royal Vendor Supplies ECD0299-	<b>Date :</b> 22/09/2017
<b>Model Name :</b> A03 - ECY-01 - 1450rpm 200mm Plastic fan Ring FAN200-38-S-GS-API	<b>Laboratory :</b> HXT
	<b>Test Number :</b> 170922-299
<b>Qmax (CFM) :</b> 377	<b>Speed (rpm) :</b> 1450
<b>Pmax (mmAq) :</b> 0.43	<b>Test by :</b> James



	Q	Qstp	P	Pstp	Voltage	Current	Power	Speed
	CFM	CFM	In-H2O	In-H2O	Volt	Amp	Watt	RPM
1	0	0	0.42	0.43	220	0.27	29.6	1434
2	39	39	0.38	0.39	220	0.26	27.4	1436
3	91	91	0.31	0.32	220	0.24	24.4	1440
4	141	141	0.20	0.20	220	0.20	19.7	1442
5	185	185	0.13	0.13	220	0.17	15.8	1440
6	235	235	0.11	0.11	220	0.16	15.1	1442
7	282	282	0.08	0.08	220	0.16	15.0	1441
8	330	330	0.04	0.05	220	0.16	14.8	1442
9	377	377	0.00	0.00	220	0.15	14.2	1445

**Airflow Test Standard**

Tested in accordance to ANSI/AMCA 210-07 Fan Air Performance Test Standard

**Disclaimer**

This document may contain confidential or proprietary information that cannot be reproduced or divulged, in whole or in part, without written authorisation from EC fan & drives. The above information is informative only and Ec fans & drives reserve the right to amend or correct at their own discretion

