

**Rapsodo**®

PRO 3.0

---

**USER MANUAL**

# CONTENTS

---

• What's Inside the Box	1
• Cloud + App	2
• Overview	3
• Operating PRO 3.0	4
• Understanding LED Displays	5
• Charging the Device	6
• Pairing PRO 3.0 and Diamond App	7
• Device Placement and Setup	8
• Calibration	9
• Specifications	10
• Session Types	11
• Diamond App	12-15
• Game Mode	16-17
• General Information	18
• Support/Contact	19

# WHAT'S INSIDE THE BOX

---



PRO 3.0

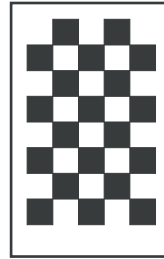

Calibration Board



Backpack



USB-C Charging Cable

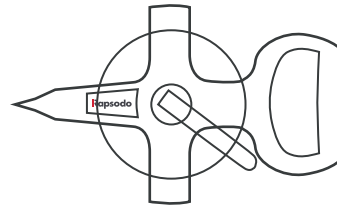

Measuring Tape



Quick Start Guide

# CLOUD + APP

---

1. Create a coach account and player profiles at [cloud.rapsodo.com](https://cloud.rapsodo.com). Log in Credentials will be the same for **Cloud & Diamond App**
- 

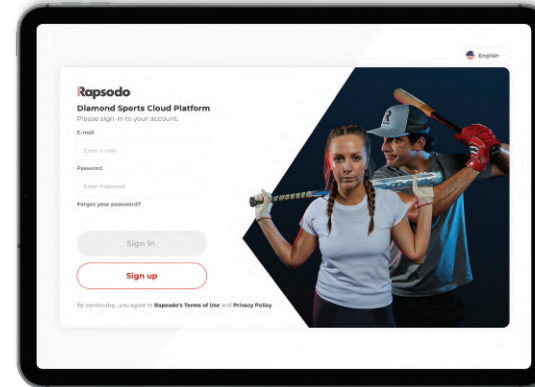

2. The Rapsodo Diamond App must be downloaded in order to use **PRO 3.0**
- 

3. Go to the **Apple App Store** and search **Rapsodo Diamond** to download



## Download App



## App Requirements

- Latest version of iOS
- iPad Air 2 or newer

## Membership requirements

- Team membership required to collect and store all data

# OVERVIEW

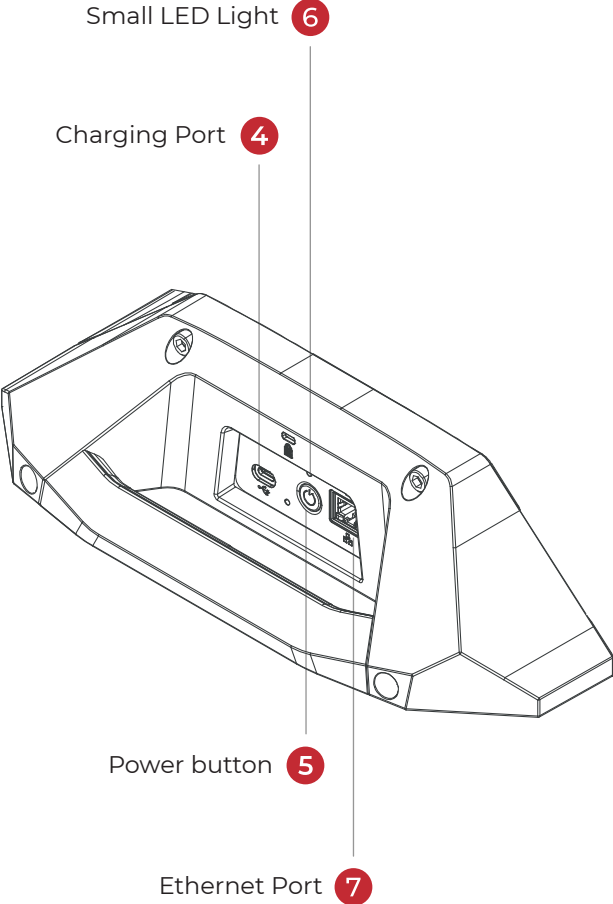
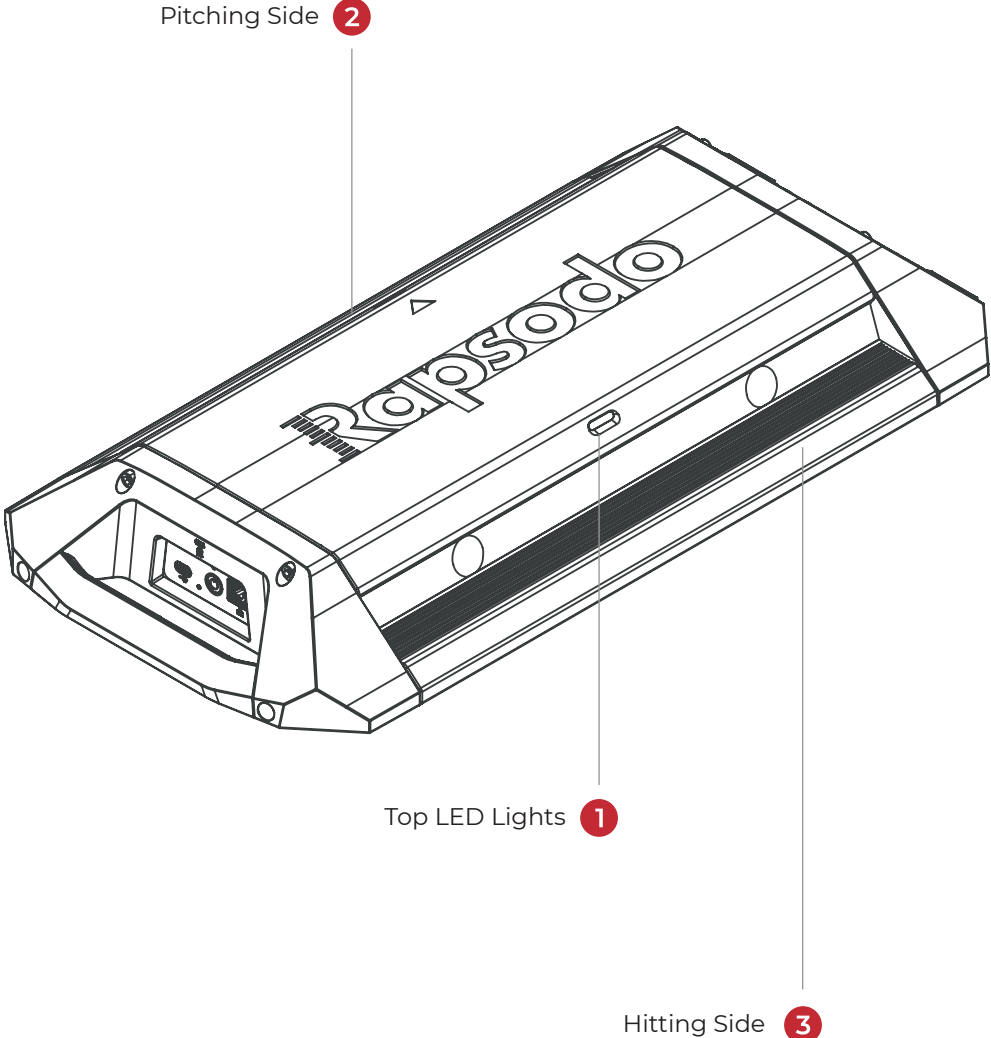

# OPERATING PRO 3.0

## Turning the unit ON

- To turn PRO 3.0 on, Press the power button
- Top LED displays will show a sequence of colors while powering on and turn **SOLID RED** when ready to connect and the small LED display under the handle will **FLASH RED**.

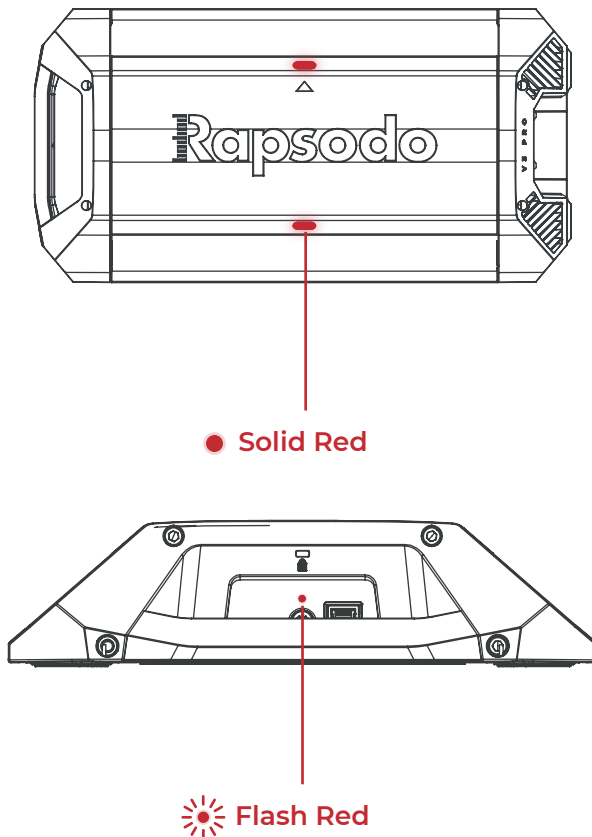

## Turning the unit OFF

- Hold down the power button for 3 seconds.
- Small LED display will **FLASH YELLOW** as the unit is powering down.

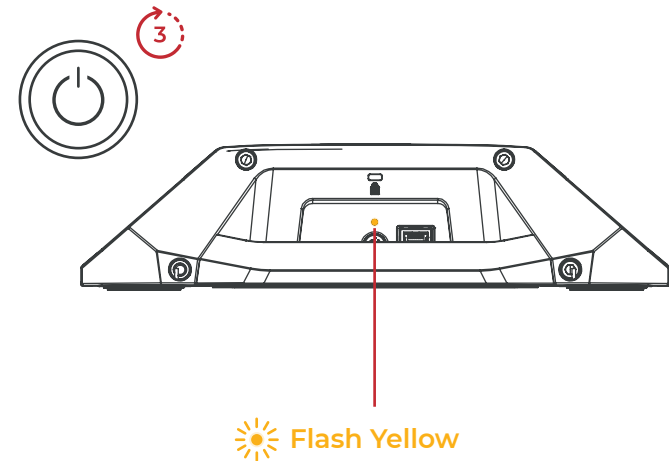

# UNDERSTANDING LED DISPLAYS

---

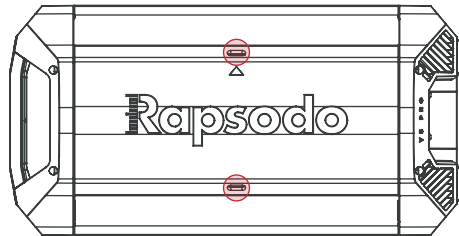

Top LED Lights

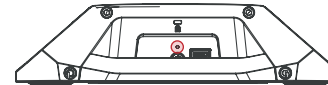

Small LED Lights

## Red Flashing Lights

Unit is powering on

## Green Light “Ready”

Ready to measure and collect data

## Blue Light “Processing”

Unit is processing data after a valid hit/pitch. Wait for the green light to appear which should take only a few seconds.

## Red Light “Not Ready”

Unit is on, but not armed

## White Light

Unit is streaming calibration images to Diamond App.

# CHARGING THE DEVICE

---

The battery can be charged by connecting the included cable into the USB-C port underneath the handle next to the power button.

- Unit can be plugged in & charging while in use

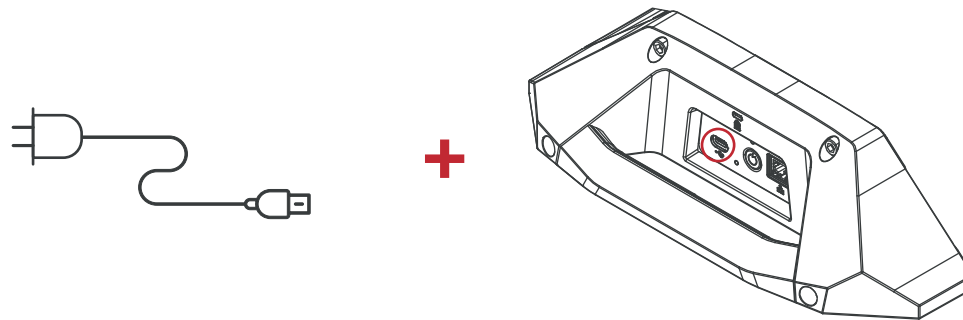

The Small LED display above the power button will show **BLUE** when the battery is charging.

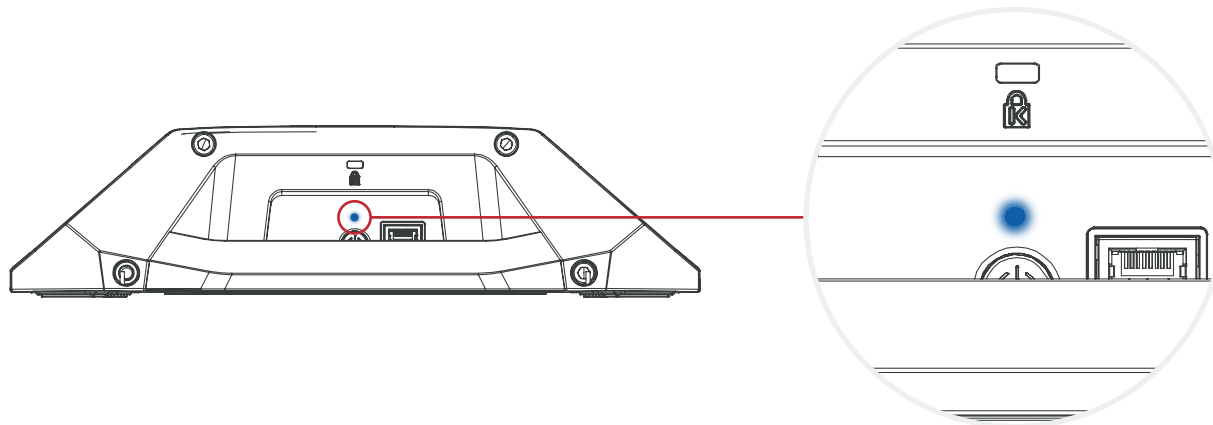



# PAIRING PRO 3.0 AND DIAMOND APP

---

1. Connect to Internet (Wi-Fi)
2. Open **Rapsodo Diamond App**
3. Open Play tab and tap **SYNC button** on the top right of the white **“Select Player”** section

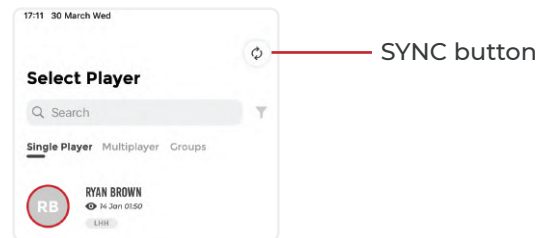

4. Once you see all your players, go to **iPad Settings > Wi-Fi** and connect to PRO 3.0 Access Point– shown as **“Rapsodo\_V3\_Serial#”** with **Password: rapsodowifi**
5. Re-Open **Diamond App > PLAY tab > click “Refresh”** Sessions will appear after a few seconds

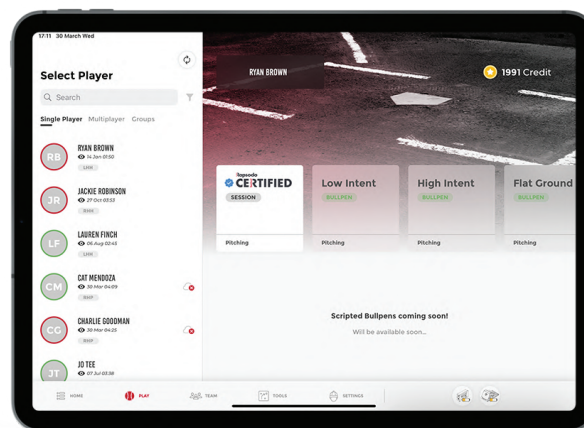

# DEVICE PLACEMENT AND SETUP

---

Using the included measuring tape, place the 0' mark at the front center of home plate and extend out through the center of the pitcher's mound. Make sure this is a straight, centered line.

- From the front of home plate, place the near side of PRO 3.0 at 17'
  - The red arrow on the top of PRO 3.0 should be facing the mound.
  - Ensure pitching mound is at 60'6.

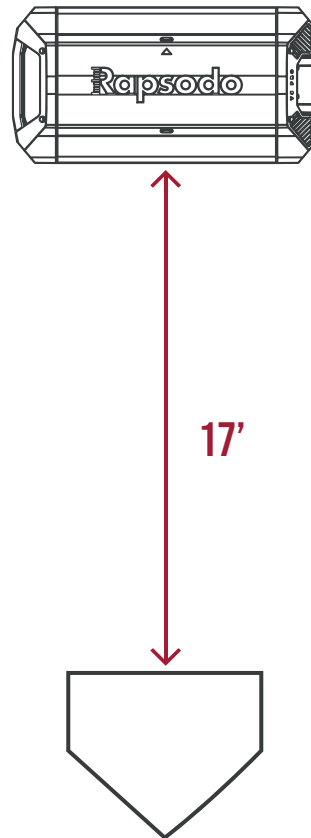

# CALIBRATION

---

1. Place the calibration board flush to the front edge of home plate and centered with the middle of the plate. Ensure the leveling bubble on the top of the board is as close to the center as possible.
2. There are 2 ways to calibrate in **Diamond App**
  - **Settings > Devices > PRO 3.0 > Recalibrate**
  - **Play > Recalibrate** (in bottom right corner)
3. Once Calibration is selected, the top LED Displays will show WHITE, and Diamond App will display calibration streams of all 3 cameras.

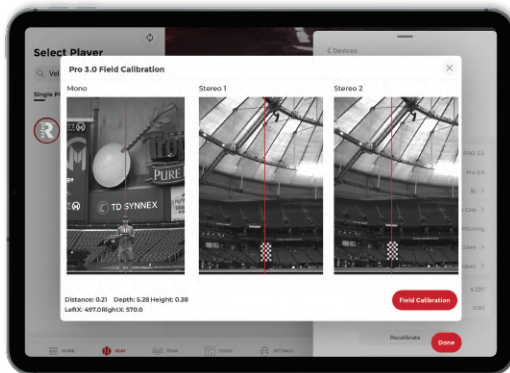

- Mono – The red azimuth line should go directly down the middle of the mound. (You should not be able to see the pitching rubber, so use a person, bat, tee, etc. to ensure the line is lined up correctly.)
- Stereo 1 & 2 – Both red azimuth lines should land on the calibration board.

**Note:** if the line on the Mono camera is in line with the middle of the rubber, but the two Stereo lines are not on the board, make sure the unit is directly in line between home plate and the mound.

4. After all 3 cameras are lined up, tap the **“Field Calibration”** button in the bottom right corner.
  - You should get a **“Calibration Successful”** message. Next, tap the **“DONE”** button in the bottom right corner to save calibration.

# SPECIFICATIONS

PITCHING DATA			
Release	Side	Spin	Total Spin
	Height		Top Spin
	Extension <span>NEW</span>		Side Spin
	Release Angle		Gyro Spin
	Height Angle		True Spin
Velocity	Release Velocity	Break	Spin Efficiency
Trajectory	3D Trajectory		Spin Axis
Strike Position	Side at Plate		Seam Orientation <span>NEW</span>
	Height at Plate		Vertical Trajectory <span>NEW</span>
			Horizontal Trajectory <span>NEW</span>
			Vertical Spin
			Horizontal Spin
		Seam Shifted Wake <span>COMING SOON</span>	

HITTING DATA					
Hit	Exit Velocity	Trajectory	Distance	Spin	Total Spin
	Launch Angle		3D Trajectory		Top Spin
	Hit Direction	Play Outcome	Hit <span>NEW</span>		
Side of Plate <span>NEW</span>	Out <span>NEW</span>				
Contact Point	Height of Plate <span>NEW</span>	Strike Position	Side at Plate		
	Depth of Plate <span>NEW</span>		Height at Plate		

# SESSION TYPES

---

PRO 3.0 MODES		
	HITTING	PITCHING
Certified	✓	✓
Batting Practice	✓	
Live	✓	✓
Tee Work	✓	
Soft Toss	✓	
Game Mode	✓	
Low Intent		✓
High Intent		✓
Pitch Design		✓
Rehab		✓
In Game	✓	✓

# DIAMOND APP

---

## Requirements:

- Rapsodo Diamond App
- Rapsodo Team Membership
- iPads: iPad Air 2 or newer
- Most recent iOS software

After adding your player roster in Diamond App or your online cloud account (pg. 2), continue with the following.

## Starting a Session:

1. See pairing and calibration section of user manual.
2. Select a player and session to begin
3. Once the main play screen loads, you can throw a pitch or take a swing, and data will start recording.

## Session Types:

- **Pitching:**
  - **Certified Assessment:** 15-pitch scripted session to analyze and evaluate each athlete. Must throw a fastball as base pitch, 5 pitches maximum. Will receive overall score of session and individual pitch scores once synced to cloud.
  - **Low Intent:** Bullpen where a pitcher will not reach 100%. Can be used for arm maintenance or pitch development where pitcher is at a lower intensity/volume to feel and track how the ball is moving differently.
  - **High Intent:** Bullpen where the pitcher faces no live hitters, but the pitcher is throwing at 100%.

# DIAMOND APP

---

- **Flat Ground:** Pitcher is not throwing off a mound.
- **Live:** Live At-Bats, scrimmages, or game like environment. Track and compare how a pitcher performs when facing live batters.
- **Rehab:** Low-intent, low volume session, where players are on a strict pitch count after injury/fatigue. Sessions will not be included in the overall averages in reports.
- **Hitting:**
  - **Certified Assessment:** 15-pitch hitting session to analyze and evaluate each athlete. Must be performed in front toss or live setting. A hitter will receive an overall score based on exit velocity, launch angle and consistency.
  - **Tee:** Stationary setting where pitch speed is 0 mph.
  - **Soft Toss:** Front toss setting where pitch speed is under 35 mph.
  - **Batting Practice:** Multi-option function where you can switch from Tee, Soft-toss, and Live within the same session.
  - **Pitching Machine:** Used only in Live/BP mode where incoming pitch speed is over 35 MPH. Can be off machine or coach pitch.
  - **Live:** Scrimmages or game like environment. Track and compare how a hitter performs when facing live pitchers.
  - **Game Mode:** Interactive, video-game like environment, where players can practice specific challenges like target practice and situational hitting.
- **PRO 3.0 ONLY:**
  - **Live on Live BP:** Batting practice session with paired incoming pitch data. Tossers must be at full pitching distance.

# DIAMOND APP

---

- **Live on Live Game:** Game or scrimmage session where hitting and pitching data are being recorded together and paired.
- **BP with Pitching Machine:** Batting practice off machine, where incoming pitch data is being recorded. Pitching machine must be at full pitching distance.

## Views:

There are 3 different screens to view when using Diamond app.

- Data screen
- Video Screen
- Field View

**Note:** Video is automatically on when beginning a session, if you would like to turn videos off select the red recording button at the top middle of the screen and it will disappear, this means videos are now off.

## Collecting Data:

- Once a hit or pitch has been completed, a processing wheel should appear, 4-8 seconds later the data should appear on the screen.
- If the processing wheel does not appear, please make sure you are properly lined up with the unit and the correct session type is being used. (For hitting sessions make sure the inbound velocity is at the appropriate speed.)



# DIAMOND APP

---

- If the processing wheel appears but no data is recorded, not enough clear readings were captured. Continue your session as normal. If no readings continue to occur, please recalibrate. If they continue to occur, please reach out to customer support.
  - Other lanes with players are at least 8 ft apart
  - No fans or HVAC units are turned on and blowing around the unit
  - No other players are practicing behind the player recording data

## Completing a Session:

1. Finish session in bottom right-hand corner.
2. Connect to Internet (Wi-Fi)

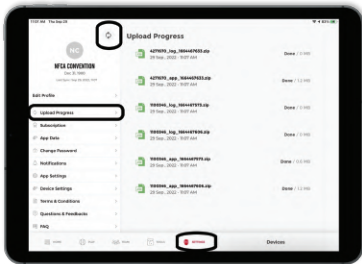

3. Open **Rapsodo Diamond App** go to **Settings > Upload Progress >** And select the arrows in the top left corner.
4. Arrows will start spinning, leave app open and awake until all files have been uploaded in the progress bar.
5. Go to the Rapsodo cloud online, those sessions will now appear under the player. If sessions are not visible, please allow your iPad more time to sync the data.

# GAME MODE

## Requirements:

- Hitting 2.0 or PRO 3.0 unit
- Rapsodo Diamond App
- Rapsodo Game Mode App
- Rapsodo Team Membership
- Recommended iPads: iPad Pro 2nd Generation or newer  
Minimum iPads: iPad Pro, iPad 7th generation, iPad 8th generation, iPad 9th generation

## Getting Started:

1. Turn on **Rapsodo Hitting** but do not connect to Rapsodo wi-fi.
2. While connected to **home wi-fi** open **Rapsodo Diamond App**.
3. Go to **settings > Subscription > License > Link Device**

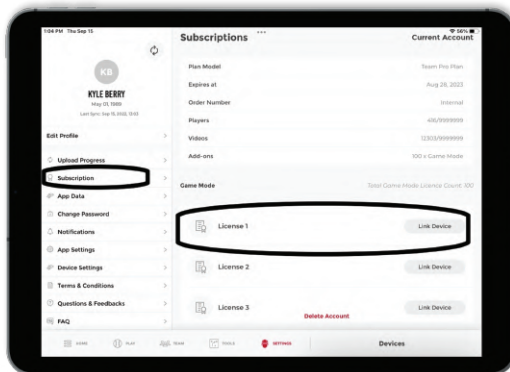

4. Once Link Device is selected, your RCE will be in the available devices. Select that device. The link device should now change to unlink and the RCE number will appear to the left.

You do not have to repeat this step once your RCE is linked.

# GAME MODE

---

## How to connect to Game Mode:

1. Connect to **Rapsodo wi-fi**
2. Open **Rapsodo Diamond App > Play > Refresh**
3. Once sessions appear scroll and select '**Game Mode**'. Screen should switch to all blue.
4. Do not exit out of Diamond app but return to iPad home screen and open **Rapsodo Game Mode**.
5. Once Game Mode is open, pull up from the bottom middle of your iPad screen to show the toolbar.
6. Drag and drop the **Rapsodo Diamond App** into the **Rapsodo Game Mode App**.



7. Once the Rapsodo Diamond app is dragged and dropped into Game Mode ball selection should appear to the left. Select which ball type you are using.
8. Select which game mode version you would like to play.
9. Tap the **Add Player** and type the player's name you want to compete with, once all players and settings have been decided, hit Play Ball!

# GENERAL INFORMATION

---

## Interference

Rapsodo PRO 3.0 is an extremely sensitive and accurate data-tracking monitor. While Rapsodo PRO 3.0 hardware has been engineered to achieve accuracy within a regular baseball environment; many everyday items like electrical appliances, computers, cell phones, bulbs, etc. may produce electrical or optical interference that can generate false readings. You need to be aware of these kinds of products in the environment where Rapsodo PRO 3.0 is used, as they may cause interferences.

## Use in Well-Lit Environments

Rapsodo PRO 3.0 should be used in well-lit locations. Performance may vary in certain lighting conditions, particularly in low light conditions, which may result in incorrect measurements.

## Do not use Rapsodo PRO 3.0 in Wet Conditions

Rapsodo PRO 3.0 is not water resistant. Do NOT expose the device to water as it may get damaged.

## App Updates

Rapsodo will periodically update and improve the features of the Rapsodo Baseball app. It is recommended that users regularly download the latest version to make for the highest monitor performance.

## Return Policy and Warranty

Rapsodo provides a (1) one-year limited warranty for manufacturing defects. Under conditions of the warranty agreement, purchasers will be entitled to repair or replacement for defective Rapsodo products. This warranty begins from the date of initial purchase. Rapsodo may also choose to refund the purchase price of the product to the purchaser, at its sole discretion. Warranty detailed information and return policy can be found online at [www.rapsodo.com/return-policy](http://www.rapsodo.com/return-policy).

## Regulatory Notice

The symbol on the product or its packaging signifies that this product must be disposed separately from ordinary household wastes at its end of life. Please kindly be aware that this is your responsibility to dispose electronic equipment at recycling centers in order to help conserve natural resources. Each country in the European Union should have its collection centers for electrical and electronic equipment recycling. For information about your recycling drop off point, please contact your local electrical and electronic equipment waste management authority. Do not dispose of the Rapsodo device with household waste. Batteries are not to be disposed of in municipal waste stream and require separate collection. Disposal of the packaging and your Rapsodo should be done in accordance with local regulations.

# SUPPORT/CONTACT

---

If you have any questions or need any assistance, please reach out to your dedicated account manager or contact us at:

@ Email: [support@rapsodo.com](mailto:support@rapsodo.com)

☎ Phone: 1.844.772.7763

🌐 [www.rapsodo.com](http://www.rapsodo.com)