



## **INSTALLATION GUIDE**

---

**V3305 V003A, V201, V205, V1001, V1007, V4008, V311-1,  
V307, V310 (#GD74)**

## ► INSTALLATION GUIDE

### INSTALLATION TIP RECOMMENDATION

If you are not handy and have no ability to install this horn, we recommend having a professional to do the installation. We do not recommend a regular auto repair shop because they might not have the know how about installation of an aftermarket air horn system. Most of the time they do not even read the installation instructions and they wind up installing the components electric connections the wrong way. We do recommend any “ALARM AND STEREO INSTALLTION SHOP” that has more experience, and specialize in installing air horn systems, and other accessories.

### TURBO COMPRESSOR & 1.5 GALLON (6 LITER) AIR TANK MODEL V3305

1. Locate a convenient area in the vehicle to mount the air storage tank. **IMPORTANT!** When selecting a mounting location for the tank, make sure that the compressor metal braided hose is close enough to connect to the tanks brass female fitting.
2. Use the tanks mounting bracket as a template, mark the hole locations and drill to size. Secure tank with hardware provided.

#### **WHOSE INSTALLATION:**

3. Using the plastic hose provided, connect the tank to the horn’s lanyard or solenoid valve. Place the brass fitting nut onto the plastic hose. Push the hose onto the tanks male fitting. Tighten the brass nut onto outlet fitting. **CAUTION:** Do not over tighten fittings.
4. Connect other end of plastic hose to horn lanyard or solenoid valve.

#### **WIRING:**

5. Connect the red wire coming out from the pressure switch terminal to (+) 12-volt power source. Splice inline the fuse holder provided. **IMPORTANT!** The red wire must be connected to a (+) 12-volt power source only when the vehicle ignition is turned on. This will protect your compressor from running continuously and being damaged if an air leak develops when the vehicle is not in operation. Suggested connection points are: blower motor, windshield wiper motor or accessory terminal on the fuse panel. Make sure the connection point has a wire that is as heavy as the compressor wire. **OPTIONAL:** A switch can be installed into the compressor’s red wire. This Will permit the driver to turn-off the system if it is not required.
6. Connect the black wire coming out from the compressor to ground. Secure the wire end to either the negative (-) side of vehicles battery or under any metal body bolt. Make sure that ground connection is freeof rust and paint. **NOTE:** The compressor is now ready to be used and will automatically start when the pressure drops in the tank. The built-in regulator will automatically turn off the compressor when the tank pressure is approximately 110 PSI. If the compressor does not shut off after 4 minutes of running time,check all air hose connections for leaks. Use soapy water or bubble solution on each fitting while the compressor is pumping. Use a thread sealant if leak persists after tightening. **CAUTION:** Do not touch compressor or fittings with bare hands during or immediately after usage, they will be hot. **IMPORTANT!** Compressor is equipped with THERMAL OVERLOAD PROTECTOR. If unit should shut off automatically during operation, do not attempt to restart compressor. Allow compressor to cool off for approximately 40 minutes before resuming use.

#### **HORN INSTALLATION:**

1. Locate a mounting location that is a solid metal surface such as the vehicle’s frame or chassis to help prevent excessive vibration, which could damage the horn. **IMPORTANT:** Do not mount horn on fender well or flexible material. For best results, the front of the horn should be unobstructed so that the sound can carry straight ahead.
2. Use the base of the horn as a template, mark the hole locations and drillholes.
3. Secure the horn with the bracket and hardware provided and tighten evenly.

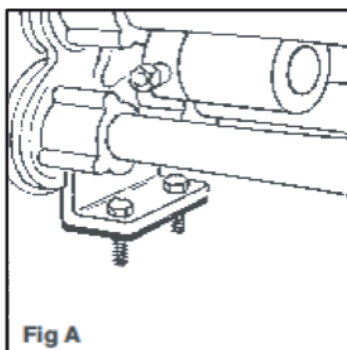

### **HOSE INSTALLATION (Fig. B)**

4. Using the provided plastic hose, cut to size and connect to the horn's electric solenoid valve, and the other end to the tank of the vehicle's high-pressure on-board air system.
5. Place the brass nut onto the end of the air hose. Push the hose onto the male inlet fitting located on the electric solenoid valve.
6. Thread brass nut onto the male fitting and tighten. **CAUTION:** Do not over tighten brass nut.
7. Connect the other end of the hose to the vehicle's on-board air tank. Make sure that the onboard air system has no pressure before attempting to connect hose to tank.

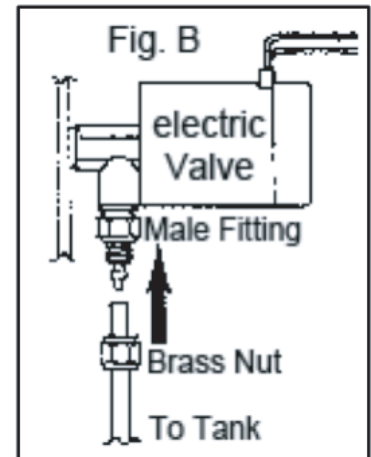

**IMPORTANT: NEVER INSTALL THE HORN TO AN AIR TANK THAT CONTROLS THE AIR BRAKES OR ANY OTHER CRITICAL OPERATING SYSTEM. IMPORTANT: MAKE SURE YOU PUT A SEALER (use Teflon tape, not included) ON ALL BRASS FITTING CONNECTIONS TO FORM A TIGHT SEAL, TO PREVENT FROM ANY AIR LEAKS LATER ON**

### **ELECTRIC VALVE WIRING (Fig. C)**

8. Connect one (1) wire from the electric valve to the positive (+) battery terminal, alternator, etc.
9. Connect the other wire of the electric solenoid valve to the horn switch.
10. Connect the horn switch's other terminal to ground, any metal body bolt that is clean of paint and rust.

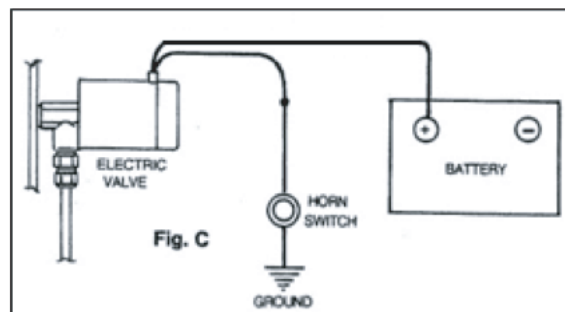

### **WARRANTY**

All "Viking Horns" products carry a warranty of six months, when properly installed and used under normal conditions, and to be free from defects in workmanship and materials from the date of the original purchaser of the product. Warranty does not cover abuse, operation in a manner inconsistent with the product's design, neglect, abnormal use, or damage resulting from exposure to the elements, any modifications or faulty installation. "Viking Horns" will fully inspect your item and if the defect is considered under warranty, we will have the option to repair, or replace the product free of charge to the original purchaser. "Viking Horns" will not be held liable for any installation charges, loss or damage of any kind incurred in the replacement or repair of any warranted product. Any return shipping charges will be paid by the end user.