



# INSTALLATION GUIDE

---

V103C-6-12/307, V103C-6-12/311-1

# ► INSTALLATION GUIDE

## **COMPRESSOR INSTALLATION:**

1. Locate an area in the engine compartment that is dry and safe from the heat of the exhaust manifold heat. Try to mount compressors side by side as far to the front of vehicle as possible to provide a good airflow around the compressors. If no room at the engine compartment, you can mount the compressors under the vehicle's carriage in a dry area. Compressors can be mounted in any position.

**IMPORTANT!** Do not mount on fender well or other flexible material.

2. Using the compressors mounting brackets as a template, mark the hole location and drill to size. Secure the compressors to the mounting surface with the hardware provided. (Fig 1.). Remove the rubber plug from the front of the compressor (applies only to compressor Model #V103C), and screw in the provided air filter. The extra O-Ring seal supplied, should be used for repairing the compressor if there is an air leak from the compressors top cover (applies only to compressor Model #V103C). Remove the top cover by loosening the top 4 bolts. Replace the O-Ring seal, and secure the top cover with the 4 bolts.

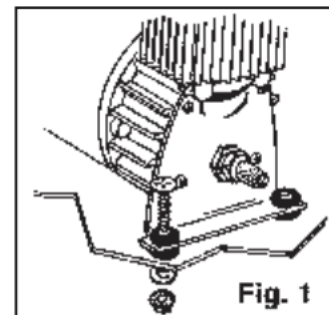

**PLEASE NOTE: DO NOT OVER TIGHTEN THE BRAIDED COMPRESSOR AIR HOSE FITTING, AND OTHER FITTINGS IN SYSTEM! BY OVER TIGHTENING FITTINGS, IT MAY CAUSE A SMALL AIR LEAK IN THE SYSTEM. WHEN THE AIR COMPRESSOR LOSES AIR CONSTATLY, IT WILL COME ON MORE OFTEN TO REPLENISH THE LOST AIR, AND EVENTUALLY GET HOT AND BREAK DOWN, AND SHORTEN THE LIFE SPAN ON THE COMPRESSOR. FITTING SHOULD BE TIGHTENED SNUG!**

## **TANK INSTALLATION:**

3. Locate a convenient area in the vehicle to mount the air tank. **IMPORTANT!** When selecting a mounting location for the tank, make sure that the compressor hose is close enough to connect to the tanks brass female fitting.
4. Use the tanks mounting bracket as a template, mark the hole locations and drill to size. Secure tank with hardwad.

## **HOSE & FITTINGS INSTALLATION:**

5. Screw in the provided 3 outlet (T-fitting) male part to the front lower 1/4" tank port. Screw in each compressor's braided air hose end into each female thread on the T-fitting
6. Using the 1/2" air hose provided, cut to size and place the brass-fitting nut onto the plastic hose. Screw the male side of the fitting onto the tanks top middle 1/2" tank port. Tighten the brass nut onto outlet fitting. CAUTION: Do not over tighten fittings.
7. Screw in the 1/4:" safety valve (provided), into the 1/4" port located at the rear of the air tank.
7. Screw in the 1/2" male fittings onto to each end of the electric valve. Follow the same as step #6 above, and tighten the 2 hoses to each end of the electric solenoid valve.

**IMPORTANT: NEVER INSTALL THE HORN TO A AIR TANK THAT CONTROLS THE AIR BRAKES OR ANY OTHER CRITICAL OPERATING SYSTEM. IMPORTANT: MAKE SURE YOU PUT A SEALER (use Teflon tape, included) ON ALL BRASS FITTING CONNECTIONS (if needed) TO FORM A TIGHT SEAL, TO PREVENT FROM ANY AIR LEAKS LATER ON.**

**NOTE: WHEN CONNECTING THE AIR VALVE ASSMBLY, MAKE SURE THE ARROW ON THE AIR VALVE POINTS TOWARDSTHE AIR HORN AIR INLET. DO NOT INSTALL THE AIR VALVE POINTING IN THE OTHER DIRECTION. THIS MAY CAUSE A RESTRICTION OF AIR FLOW TO THE HORN.**

## **WIRING COMPRESSOR:**

5. Use the provided RED and BLACK 10-gauge electric wire for compressors connections. **IMPORTANT!** The red wire must be connected to a (+) 12-volt power source only when the vehicle ignition is turned on. This will protect the compressors from running continuously and being damaged if an air leak develops when the vehicle is not in operation. Suggested connection points are: blower motor, windshield wiper motor or accessory terminal on the fuse panel. Make sure the connection Poit has a wire that is as heavy as the compressors wire.



## INSTALLATION TIP RECOMMENDATION

If you are not handy and have no ability to install this horn, we recommend having a professional to do the installation. We do not recommend a regular auto repair shop because they might not have the know how about installation of an aftermarket air horn system. Most of the time they do not even read the installation instructions and they wind up installing the components electric connections the wrong way. We do recommend any "ALARM AND STEREO INSTALLTION SHOP" that has more experience, and specialize in installing air horn systems, and other accessories.

### IMPORTANT INFORMATION BELOW:

#### Upon completion of installation:

1. We you finish installing the air horn kit we recommend checking the system for air leaks.

Start the vehicle and let the air compressor fill up air into the air tank. Depending on the supplied air pressure switch ratings it will stop the compressor at around the off rated point marked on the air pressure switch. Take a look at the air pressure gauge to verify the air pressure is around the air pressure Off ratings that is marked on the switch.

2. Fill a small container with soapy water and dump a rag into the soapy water. Using the wet rag smear the soapy water all over the connecting fittings, hoses, screwed in threads, and look for any air bubbles. If you detect any air bubbles, you'll have to repair the leak. Important: the purpose of checking for air leaks is to prevent from the air compressor to work more than the usual. When the air compressor loses air constantly, it will come on too often to recoup the air lose, and eventually get hot, burn out, and seize from operating. Also it might drain your battery if the vehicle is parked for a long period.

3. We highly recommend installing a master On/Off switch (not included), to shut off the horn system when the vehicle is not in use, or parked for the night. This will prevent from the air compressor to go on and off many times, if you have an air leak in the system. This master on/off switch can be spliced into the compressor's positive (+) wire, and it should be installed inside vehicle, in a location reachable by the driver.

4. After you checked for leaks, and you did not find any, and the compressor keeps pumping over the rated max pressure marked on the air pressure switch and does not stop. Chances are that either the air pressure switch is bad or a wrong connection of the switch.

5. The switch should be spliced into the ground wire only as described in chapter 10. Otherwise it will not function right, or short out the system.

6. If the compressor does not come on, there might be a few issues to look at. Check for a burned fuse on the circuit you connected it to. Also check the inline fuse on the compressor's positive (+) red wire, if it burned out. If that is not the case, remove the air compressor and test it next to the vehicle's battery by connecting the red compressor wire to the positive (+) side of the battery, and connecting the black compressor wire to the negative (-) side of the battery. If the compressor comes on, then it might be something wrong with your electrical connections. They might be crossed, or the black ground wire is not grounded to a clean metal surface. The ground wire on the compressor should be connected to 1 side of the air pressure switch, and the other side of the pressure switch should be connected to ground that is clear of rust, dirt or greasy surface.

**For any questions you may have you can call out tech support during business hours (eastern time) from 9:30 AM to 3:00 PM at: (844) 808-9171. We will do our best to help you with any issue(s) you are having.**

### **WARRANTY**

All "Viking Horns" products carry a warranty of six month, when properly installed and used under normal conditions, and to be free from defects in workmanship and materials from the date of the original purchaser of the product. Warranty does not cover abuse, operation in a manner inconsistent with the product's design, neglect, abnormal use, or damage resulting from exposure to the elements, any modifications or faulty installation. "Viking Horns" will fully inspect your item and if the defect is considered under warranty, we will have the option to repair, or replace the product free of charge to the original purchaser. "Viking Horns" will not be held liable for any installation charges, loss or damage of any kind incurred in the replacement or repair of any warranted product. Any return shipping charges will be paid by the end user.