



INSTALLATION GUIDE

Model V905, V905C, V906, V906C, V907-SS Sirens

► INSTALLATION GUIDE

MOUNTING:

1. Locate an area in the engine compartment that is dry and safe from exhaust manifold heat using the siren's mounting bracket as a template mark holes location and drill to size. Secure the siren to the marked location

WIRING:

2. Connect the siren's REDWIRE to (+) 12-volts positive such as, battery, alternator or accessories. Use 16 gauge or heavier wire.

IMPORTANT: Always make sure that there is a 10-amp fuse holder used in the circuit (not included) to protect the vehicle. The fuse should never be more than ten-(10) inches from the battery, or (+) positive connection point.

3. Connect the siren's BLACKWIRE to the on/off switch terminal (switch not included).
4. Connect the other terminal of the on/off switch to ground, any metal body surface that is clean of paint and rust..

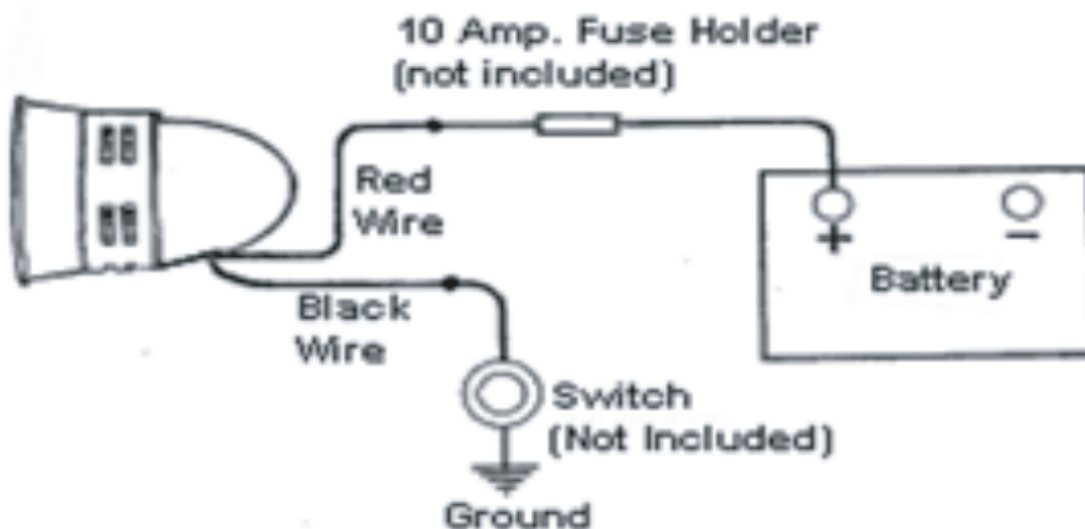

WARRANTY

All "Viking Horns" products carry a warranty of six months, when properly installed and used under normal conditions, and to be free from defects in workmanship and materials from the date of the original purchaser of the product. Warranty does not cover abuse, operation in a manner inconsistent with the product's design, neglect, abnormal use, or damage resulting from exposure to the elements, any modifications or faulty installation. "Viking Horns" will fully inspect your item and if the defect is considered under warranty, we will have the option to repair, or replace the product free of charge to the original purchaser. "Viking Horns" will not be held liable for any installation charges, loss of damage of any kind incurred in the replacement or repair of any warranted product. Any return shipping charges will be paid by the end user.